

This Owner's Manual is provided and hosted by [Appliance Factory Parts](#).



# Holland BH421-SS1 Owner's Manual

[Shop genuine replacement parts for Holland  
BH421-SS1](#)



[Find Your Holland Grill Parts - Select From 32 Models](#)

----- Manual continues below -----

READ THIS BOOK FIRST



# Instruction Manual

## The Premier

BH-421-SS-1

*This Is A Revolutionary Gas Grill!*

American Gas Association Design Certified  
Canadian Gas Association Design Certified

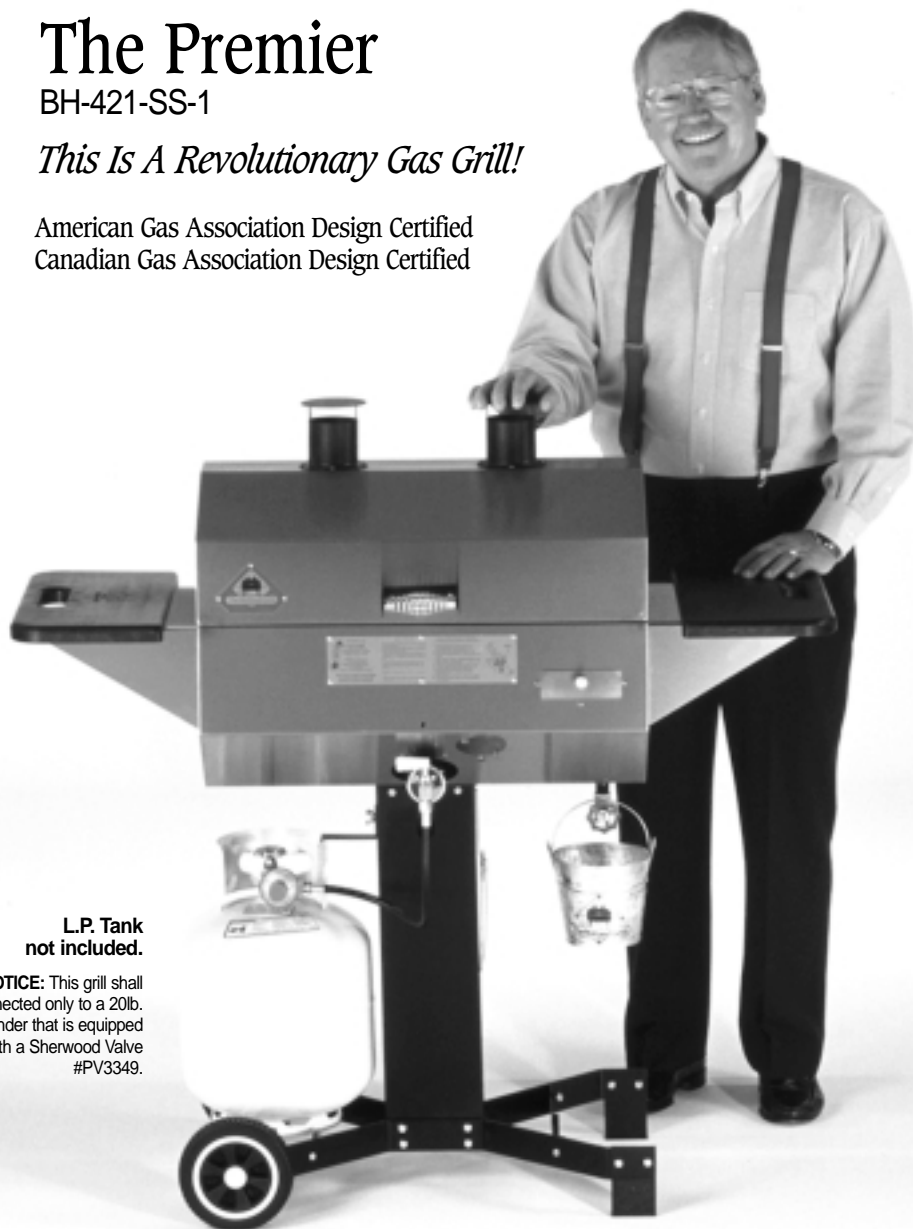

**L.P. Tank  
not included.**

**L.P. NOTICE:** This grill shall  
be connected only to a 20lb.  
L.P. cylinder that is equipped  
with a Sherwood Valve  
#PV3349.

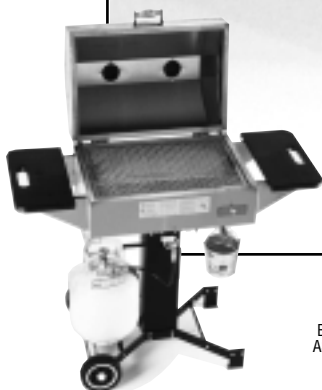

The only Grill  
**GUARANTEED**  
not to flare up!

*Dear Friend,*

*I wish to personally thank you for purchasing one of my Holland Grills. It's my goal that you, your family and friends enjoy your grill for many years to come.*

*It's important that you are aware that the Holland is unlike any other grill. By design, it allows you to grill, steam or smoke, without the fear of flare-ups commonly associated with competitive brands. Now you can enjoy being with your friends while preparing quality food without the worry and nuisance of trying to control fires.*

*Not only will you be able to enjoy time with friends while you grill in comfort, you'll be able to do so for years to come. My grill is made of quality materials which give it a sturdiness that will last for years. Unlike other grills on the market, I do not intend for my customers to deal with a long list of replacement parts and the inconvenience of waiting for the parts. This grill was designed and made for your trouble-free outdoor cooking.*

*Since the Holland does not operate like other grills, it is important to me that you follow all the instructions. I have spent a large portion of my life developing a product that is safe, easy to use and grills to perfection; I personally want to know your comments, questions or any problems that arise from the grill or our field representatives. Please feel free to contact me with your comments, or contact a local dealer who will help you with parts, accessories, literature and warranty.*

*Thank you,*

*Brad Holland*

**IT'S IMPORTANT THAT YOU, THE OWNER, READ THE ENTIRE MANUAL BEFORE ASSEMBLING OR USING THE GRILL. IF YOU ALLOW SOMEONE ELSE TO USE YOUR GRILL, MAKE SURE THEY HAVE READ THE INSTRUCTIONS AND UNDERSTAND THEM BEFORE YOU LET THEM OPERATE THE GRILL.**

# OWNERS MANUAL

## FOR YOUR SAFETY

IF YOU SMELL GAS:

1. SHUT OFF GAS TO THE APPLIANCE.
2. EXTINGUISH ANY OPEN FLAME.
3. OPEN LID.
4. IF ODOR CONTINUES, IMMEDIATELY CALL YOUR GAS SUPPLIER OR FIRE DEPARTMENT.

## FOR YOUR SAFETY

1. DO NOT STORE OR USE GASOLINE OR OTHER FLAMMABLE VAPORS AND LIQUIDS IN THE VICINITY OF THIS OR ANY OTHER APPLIANCE.
2. AN LP CYLINDER NOT CONNECTED FOR USE SHALL NOT BE STORED IN THE VICINITY OF THIS OR ANY OTHER APPLIANCE.

## IMPORTANT

The grill should be lit and allowed to operate for at least 30 minutes before using for the first time to allow preservative to burn off. After smoke stops coming out of stacks, grill is ready for your use and enjoyment.

THIS GRILL IS NOT FOR  
COMMERCIAL USE

THIS GRILL IS NOT INTENDED TO BE  
INSTALLED IN OR ON RECREATIONAL  
VEHICLES AND/OR BOATS

THIS COOKING APPLIANCE IS FOR  
OUTDOOR USE ONLY AND SHALL  
NOT BE USED IN A BUILDING,  
GARAGE OR ANY OTHER  
ENCLOSED AREA.

## SAFETY INFORMATION

### WARNING: FOLLOW LOCAL CODES

The installation of this appliance must conform with local codes or in the absence of local codes, conform to the National Fuel Gas Code ANSI Z223.1.

Installation shall be in accordance with CAN/CGAB149.1 natural gas installation code or CAN/CGA-B149.2 propane installation code and local codes where applicable.

### YOUR GRILL IS MADE FOR OUTDOOR USE ONLY

A minimum clearance of 18 inches on the sides and back must be kept between the grill and combustible construction. The grill shall not be located under overhead unprotected combustible construction.

THE VENT STACKS AND THE INTAKE AIR OPENING should never be blocked or closed while operating.

## THE FUEL SYSTEM

Gas grills are used SAFELY by millions of people when following simple SAFETY precautions.

The items in the fuel system are designed for operation with the Holland Grill. They must not be replaced with any other brand. (See parts list for replacement items.)

**GAS BURNER:** The gas burner is made of heavy cast iron and should not require maintenance other than inspection for insect nests inside the venturi. If you remove the burner for cleaning, it must be reinstalled exactly as removed.

**AIR SHUTTER:** See Item 10 in lighting instructions (See figure 8 for details.)

**BURNER VALVE:** The burner valve is operated in only two positions. The Off position is when the handle is across (perpendicular to) the burner, which stops the flow of gas. When the valve has been set in the Off position, it is important to close the valve at the LP gas cylinder. The LP gas cylinder is the primary valve and must be closed when the grill is not in use. The On position is when the handle is in line with the burner (See figure 8 for details. See lighting instructions for more information.) The burner valve controls the heat allowed in the grill by means of a plug orifice. This device is set at the factory and must not be tampered with or replaced.

ONLY A FACTORY SUPPLIED VALVE SHOULD BE USED. (See the parts list for replacement items.)

**LP GAS HOSE:** The LP gas hose is designed for use with LP gas only. Use with any other gas is dangerous. The hose is made of a flexible material to make it easy to install. This material is subject to considerable twisting and turning during installation. It is very important that the hose be inspected for cracks, cuts, abrasions, wear and loose fittings. The visual inspection should include leak testing the entire length of hose and fittings. (See final assembly instructions for more information.)

If the hose shows signs of damage or leakage, it must be replaced prior to the operation of the grill. Only a factory authorized replacement part can be used. (See the parts list for replacement items.) Failure to properly inspect or replace hose with an authorized replacement may result in accident or injury.

IF STACK FILTERS BECOME DIRTY OR CLOGGED THEY CAN BE REMOVED AND THE GRILL OPERATED SATISFACTORILY WITHOUT THEM UNTIL NEW FILTERS ARE OBTAINED AND INSTALLED.

## LP GAS REGULATOR - CAUTION -

The gas pressure regulator provided with this appliance must be used. This regulator is set for an outlet pressure of 11 inches water column. Substitution of regulator by any other device or any other manufacturer's regulator is dangerous and could result in serious injury. (See the parts list for replacement items.)

**PROPANE FUEL:** Warning – propane is a flammable gas and improper handling may result in explosion and/or fire and serious accident or injury. Your grill is designed to operate on LP gas and is equipped with the proper orifice for this gas. **CAUTION:** Do not connect this grill to any gas supply except propane or natural gas. Propane gas is heavier than air and will settle in low areas. Make certain adequate ventilation is available when using your grill and that the gas cylinder is stored outside in a well ventilated place out of reach of children when the grill is not in use.

**LP GAS CYLINDER:** This grill is designed and intended to be used with an LP gas cylinder with a nominal LP gas capacity of 20 pounds. Such a cylinder is approximately 12-3/8" in diameter with an overall height of 18-1/16". The Holland Grill does not come with an LP gas cylinder. This must be purchased separately and is available at most hardware stores. The cylinder used must be constructed and marked in accordance with the specifications for LP gas cylinders of the U.S. Department of Transportation (DOT) (4BA-240) and the National Standard of Canada CAN/CSA-B339, cylinders, spheres, and tubes for the transportation of dangerous goods. Only a cylinder equipped with an overfill protection device (OPD) should be used.

THE LP GAS CYLINDER shall be used only outdoors in a well ventilated space and not in a building, garage, or any other enclosed area. The LP gas cylinder is designed to be used, stored, and transported in the upright position. The Holland Grill may be stored indoors if the LP gas cylinder is removed and stored outdoors. NEVER turn the cylinder upside down or on its side. Always transport, store and use your cylinder in the upright position.

FIGURE 1-A

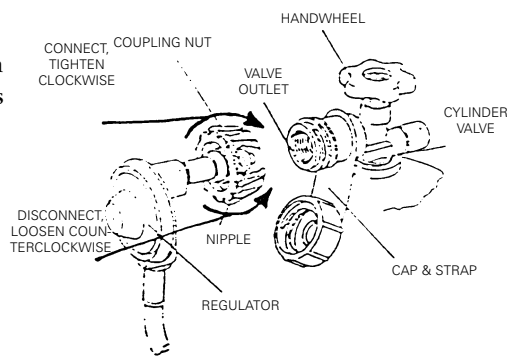

The cylinder must be provided with a Sherwood valve, part #PV3349, which will connect with (quick connect) the QCC-1 Fitting provided on each of our LP (propane) grills. Must also have a safety relief device having a direct communication with the vapor space of the cylinder. The cylinder supply system must be arranged for vapor withdraw. The cylinder shall include a collar to protect the cylinder valve. The grill must be connected to the gas supply by a hose.

**DO NOT transport a full or empty gas cylinder in a closed automobile trunk or in a closed passenger area.**

Filling the gas cylinder requires removing it from the grill. The cylinder is attached to the grill by connecting the regulator assembly to the inlet portion of the gas cylinder valve. This connection is made by the QCC-1 fitting pictured in Figure 1-A. The large plastic nut fits on the outside of the threads and turns right, or clockwise to tighten. No tools are necessary. Hand tight is sufficient. If a good connection is not achieved, the safety valve inside will not permit the proper amount of gas to flow. When connecting the regulator to the cylinder valve, be sure the pressure relief valve is directed away from the front and away from the grill. If the relief valve should open, the propane will be directed where it is likely to do the least harm. To disconnect regulator assembly turn large plastic nut left or counter-clockwise.

When disconnecting and connecting the gas cylinder, be careful that the regulator assembly does not strike the grill, the ground, or any other surface. If any difficulty at all is had in connecting or disconnecting the regulator assembly to the cylinder valve, contact your local gas supplier for assistance.

When disconnected from the cylinder, a valve cap must be installed. (See figure 1-A.) Failure to install a valve cap when the cylinder is disconnected from the fuel system is dangerous and may result in accident or injury.

When reconnecting the LP gas cylinder, be sure to tighten the fitting until snug. This connection, as well as all other fittings and connections between the cylinder and burner valve, should be inspected for damage and leak tested after every filling or reconnection. (See lighting instructions, Figure 8.)

Keep any electrical supply cord and fuel supply hose away from any heated surface.

**NATURAL GAS:** If natural gas is used, contact your local supplier to set it up properly. The N.G. Holland Grill is set to operate at 7 inches water column pressure, using an orifice with a #54 drill size. If your grill seems too hot, first call your local gas company to determine what pressure you have. Never allow anyone to change orifice size without authorization from factory.

**ASSEMBLY INSTRUCTIONS**  
BH-421SS-1 GRILL

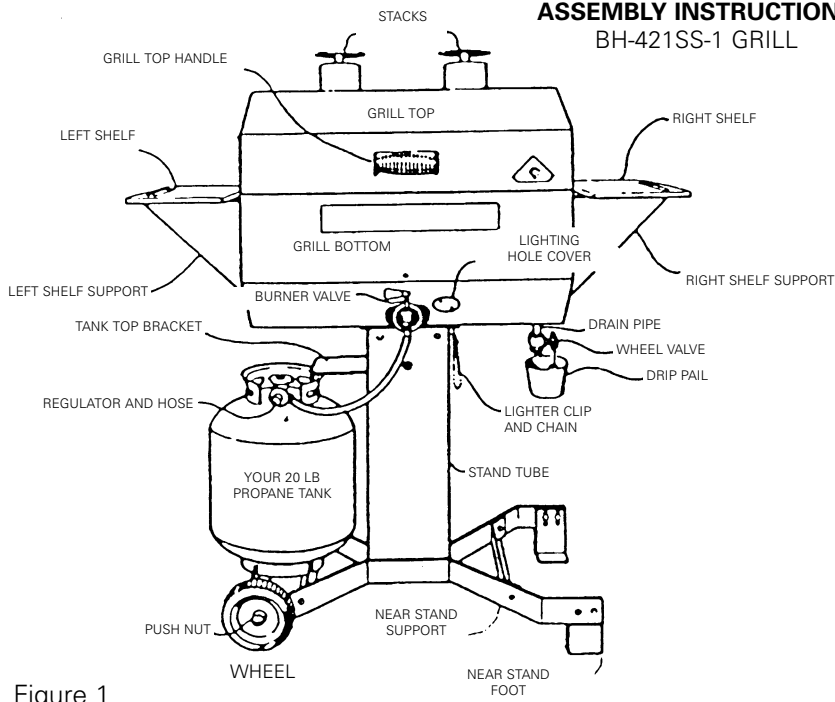

Figure 1

NOTE: All bolts are 1/4-20 x 1/2, and 8/32 with phillips head.

NOTE: use a lock washer under each nut where used, and under each bolt head where threaded holes are provided.

**PREMIER GRILL**  
**ASSEMBLY**  
**INSTRUCTIONS**

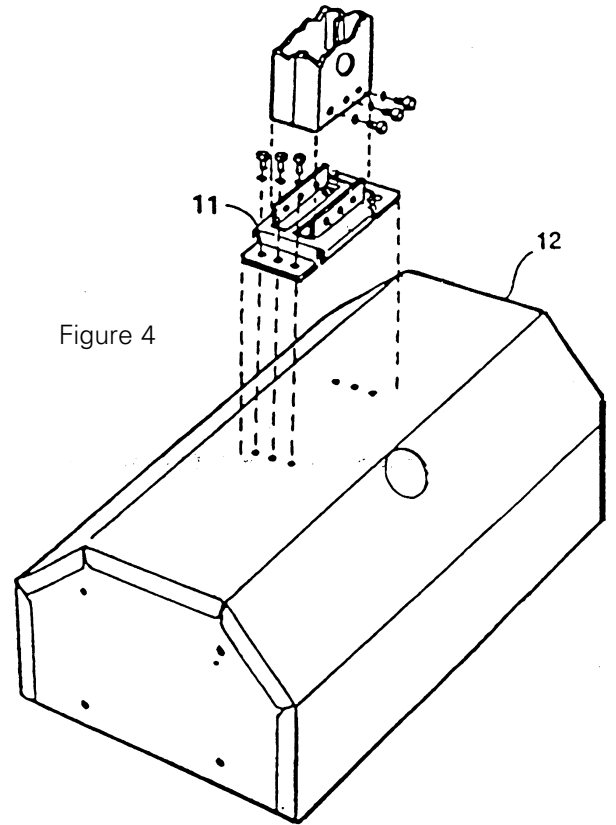

Figure 4

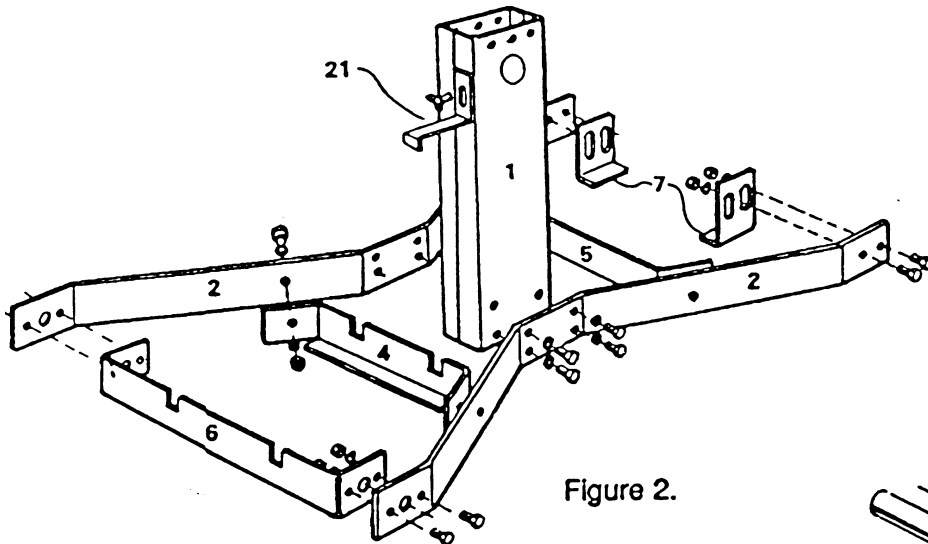

Figure 2.

If your grill wobbles after putting it in place, adjust the higher of the two feet by loosening the two nuts and bolts retaining it and slide the foot down until it contacts the floor, and retightening the nuts and bolts. Be sure the narrow flanges are nearest the floor and facing each other.

**MAKE SURE THE GRILL IS LEVEL BEFORE USING IT.**

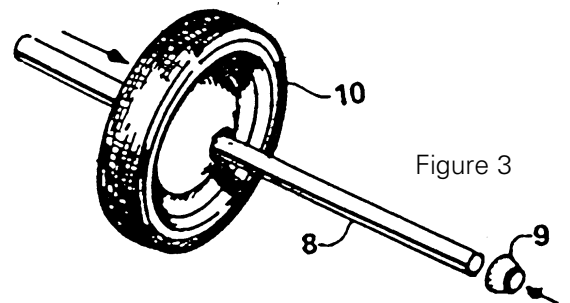

Figure 3

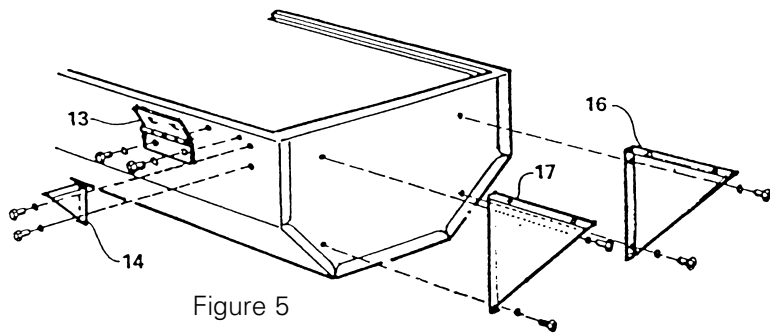

Figure 5

## ASSEMBLY

### TOOLS NEEDED FOR ASSEMBLY

1. 7/16" COMBINATION WRENCH
2. 7/16" NUT DRIVER
3. PHILLIPS SCREWDRIVER (MED. SIZE)
4. 11/32" COMBINATION WRENCH OR NUT DRIVER
5. 3/8" NUT DRIVER

The Holland Grill has been designed for easy assembly. Most items are pre-installed at the factory. The items to be assembled have been outlined in the parts list. In addition, complete instructions and visual aids are included in this manual. One of the most important items is GAS LEAK TESTING, covered under the fuel system and lighting instructions.

1. On a flat surface (table or carport floor), OPEN AND EMPTY BOTH BOXES. REFER TO THE CONTENTS LIST TO BE SURE NO PARTS ARE MISSING.

2. Refer to fig. 2. Select the following parts for assembly:

- |     |                        |
|-----|------------------------|
| No. | Description            |
| 1.  | Stand Tube             |
| 2.  | (2) Stand Tube Support |

Use 1/4-20 bolt in all parts for sections 2a through 2e.

2a. Set Stand Tube upright with the end having 4 holes on floor and the round access hole in front. Slide Tube Supports against each side of tube, aligning four holes on each side. Start, but don't tighten, eight bolts and lock washers.

2b. Select Left Mid-Brace (Part 4). Place it as shown in Figure 2. Be sure notches are up and narrow flange is away from Stand Tube.

2c. Repeat for Right Mid-Brace (part 5).

2d. Select axle brace (part 6). Place it between left ends of Stand Support. Attach it

to Supports with two bolts, nuts and washers at each end. Be sure notches are up and Narrow Flange is toward Stand Tube. AT THIS POINT, TEMPORARILY INSERT AXLE THROUGH HOLES IN LEFT END OF STAND SUPPORT AND AXLE BRACE.

Be sure Stand Tube and Supports are flat on the floor and tighten all bolts securely.

2e. Install a Stand Foot (part 7) at the end of each Stand Support having only two holes. Be sure the Narrow Flanges are nearest the floor and facing each other.

3. Refer to Figure 3. Select the following parts for assembly:

No.	Description
8	Axle
9	Push Nut (2 each)
10	Wheel (2 each)

3a. Remove Axle from Stand Support, and install a Push Nut (part 9) on one end and seat it with a sharp hammer rap. Use a block of wood to protect the nut.

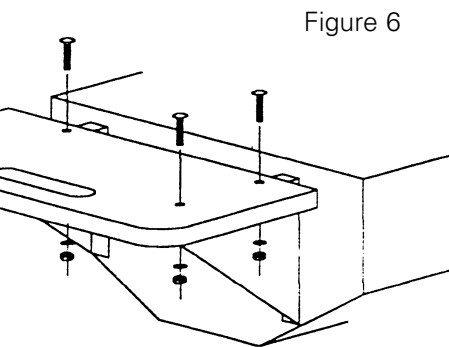

Figure 6

3b. Slide a Wheel (part 10) onto Axle with whitewall toward nut.

3c. Reinsert Axle into Stand Support, slip second Wheel into place with whitewall out and install second Push Nut as before.

4. Carefully remove the parts inside the Grill Bottom and invert the bottom.

4a. Refer to Figure 4. Install the Grill Bottom Mount (part 11) to Grill Bottom (part 12).

4b. Invert the Stand Tube and Support assembly and slip the open end of the Tube over the projecting Flange of the Bottom Mount, align the three holes on each side and install a 1/4-20 bolt and washer in each. When all are started, tighten securely.

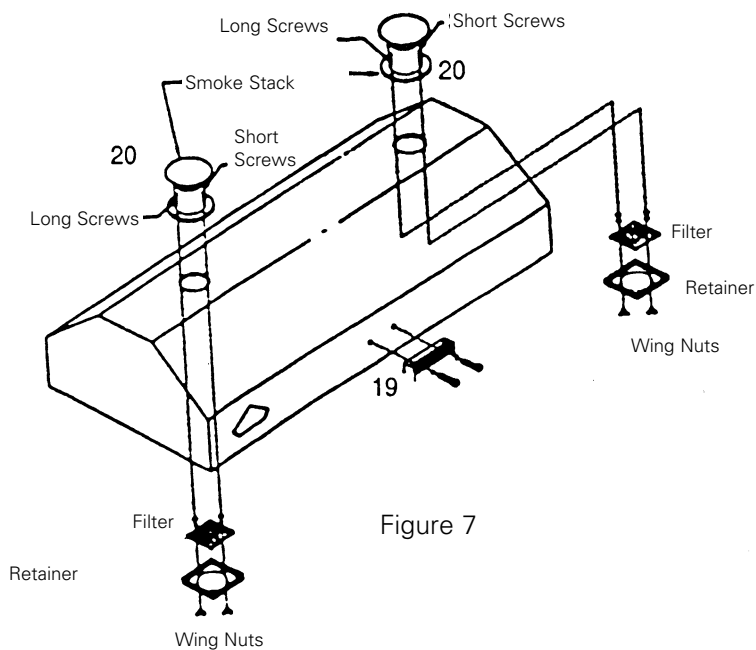

Figure 7

5. Refer to Figure 5. Select the following parts for assembly:

- no. description
- 13 Hinges
- 14 Grill Top Stop (right)
- 15 Grill Top Stop (left, not shown)
- 16 Shelf Mount (2 each right)
- 17 Shelf Mount (2 each left)

5a. Place Grill Top squarely on Grill Bottom.

5B. Attach both hinges to back of Grill Top and Bottom with four bolts and washers in each. When all are started, tighten securely.

5c. Attach Top Stops to Bottom with two bolts and washers in each using the threaded holes provided. The Flanges should point toward each other. Tighten securely.

5d. Attach a Right and Left Shelf Mount to each end of Grill Bottom using the threaded holes provided with two bolts and washers each. The Flanges should be towards each other. Leave loose.

6. Refer to Figure 6. Select the two Shelves (part 18), and using four bolts and washers on each, attach them to the Shelf Mounts as shown. When all bolts are started, tighten Mount-to-bottom bolts and then Mount-to-shelf bolts securely.

7. Refer to Figure 7. Select the Grill Top Handle (part 19) and attach it to the Grill Top as shown with two 1/4-20 bolts and washers in the threaded holes provided.

7a. Attach the Smokestacks to the Lid as per the instructions. Put the LONG no. 8 screws supplied in the Filter Hardware bag in the middle of the flat portion of the top and the short screws to the front and back as shown. Place nut and washer on each bolt and tighten securely. See Figure 7.

7b. Place the Filter Pad between the screws on the inside of the lid.

7c. Fit the Filter Retainer over the pad and the screws. The two long screws should protrude through the Filter Retainer.

7d. Thread the two wingnuts onto the long screws, trapping the Retainer. Hand tighten the nuts. They should be just tight enough to firmly capture the Filter, but not tight enough so the Retainer is overly distorted.

8. Install the short length of Drain Pipe in the female threaded coupling in the right end of the Drip Tray. Tighten with pliers or pipe wrench.

9. Open the Grill Top against the Stops. Carefully set the Drip Tray in the Grill Bottom using the hand tabs provided at each end. Be sure the Drain Pipe extends through hole in Grill Bottom.

**FOR NATURAL GAS SUPPLY**

The Holland Grill, including the gas off-on valve, must be disconnected from the gas supply during any pressure testing of that system, at test pressures in excess of 1/2 psig.

The Holland Grill must be isolated from the gas supply piping system by closing the individual manual shut-off valve during any pressure testing of the gas supply piping system at test pressure equal to or less than 1/2 psig

12. Attach the Tank Top Brace (see Figure 2) to the Stand Tube with the wing bolt through the slotted hole in the brace. Slide Brace down until outer end hooks over top ring of propane tank. Tighten securely.

13. Install Regulator Valve on propane tank by connecting the Regulator Assembly to the inlet portion of the Gas Cylinder Valve. This connection is made by the qcc-1 fitting. The large plastic nut fits on the outside of the threads and turns right, or clockwise, to tighten. No tools are needed. Hand tight is sufficient. If a good connection is not achieved, the safety valve inside will not permit the proper amount of gas to flow.

14. HANG DRIP PAIL OVER BRASS WHEEL VALVE.

15. CHECK ALL BOLTS AND NUTS FOR TIGHTENING AND GO ON TO LEAK TESTING (SOAPY WATER TEST. SEE FIGURE 8).

Figure 8

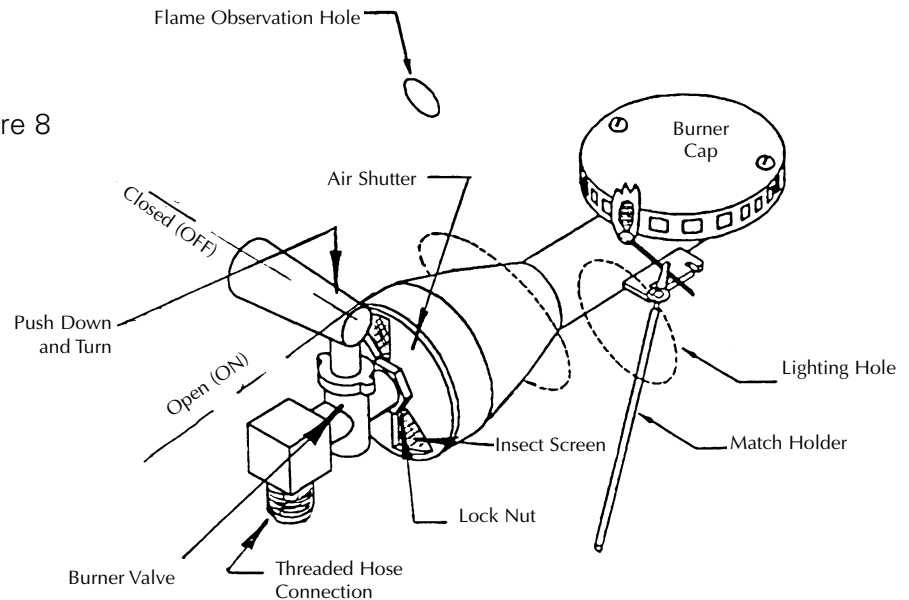

10. Screw the Brass Wheel Valve onto the end of the Drain Pipe that extends below the Grill Bottom. Hand tighten only. Be sure to open valve.

11. Referring to Figure 1, place your 20-lb. propane tank bottom ring in the slots in the Axle Brace and Left Mid-Brace.

**SOAPY WATER TEST**

In a small bowl mix half liquid detergent and half water. Turn on propane tank valve. Using a small brush, soap all connections from tank to grill and look for bubbles. Correct all leaks before proceeding. Turn off propane tank valve.



## LIGHTING INSTRUCTIONS

See figure 8

1. Make sure the propane tank valve and the burner valve are both fully off.
2. Open the grill lid and allow five full minutes to air out.
3. During this time, inspect the gas system for damaged hose or loose fittings. Check the hose for wear, abrasions, cuts or kinks. If any damage is found, replace hose using only factory-approved replacement hose. Never attempt to light this or any gas grill with a cracked, split, braided, or severely kinked hose or with any broken or leaking fittings.
4. Rotate the plate covering the lighting hole and look for the burner head.
5. Place a match in the alligator head attached to the stand tube on a bead chain.
6. Open the propane tank valve.
7. Light the match, and with right hand, pass it through the lighting hole and place it beside the burner head. Make certain it is still lit.
8. With left hand, open the burner valve by pushing it to the right and rotating it outwards (counter-clockwise) all the way. See Figure 8.
9. When the burner lights, withdraw the match. A propane lighter may also be used.

10. Loosen the lock nut with a 5/8" open end wrench so you can turn the air shutter. Adjust the flame by turning the air shutter on the face of the burner valve slowly. When most of the orange color has left the flame, and it has become uniformly pale yellow-to-blue, the flame is properly set. There should be no need for re-adjustment for the life of your Holland Grill, but it is wise to check the flame color each time you light your grill. Lock nut should be tight against valve.

Make sure while looking to adjust or check flame to use the peep hole just above valve. See below:

The flame should be blue in color. NOTE: Some yellow tipping may occur. It's not unusual and will not affect the performance of the grill.



PROPER AIR SHUTTER SETTING

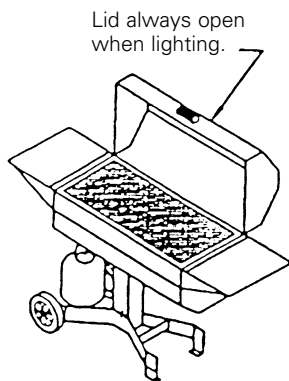

11. Close lighting hole cover and proceed to COOKING INSTRUCTIONS.

12. If the burner did not light properly, wait 5 minutes before attempting re-light, then repeat steps 1-9.

13. If the grill fails to light after the second attempt, call your local LP gas dealer for professional assistance.

14. With the burner lit, gently close the lid and allow the grill to warm for 20-30 minutes.

NOTE: If for any reason the burner should go out, shut off gas at the burner and the LP cylinder. DO NOT attempt to re-light without repeating steps 2-9.

NOTE: The Holland Grill uses a 2-position gas valve on the burner control. The illustration (Figure 8) shows the handle in the OFF position. To turn ON, push the handle to the right and turn outward in direction of the arrow (counter-clockwise) for its full travel (about 90 degrees). NEVER operate the Holland Grill with the handle in any intermediate position.

**IMPORTANT - FIRST TIME USE:** It is important that the grill be lit and allowed to operate at least 30 minutes before any food is placed on the grill grid. Some smoke may appear during this period. This is the preservative used during manufacturing. After initial heating, the grill is ready for use. After burning off the grill, spray the food grid, drip pan and the inside of the lid with PAM or similar spray, so food does not stick to the grid and the inside is easier to clean.

## TURNING GRILL OFF

1. Open lid
2. Turn burner valve OFF
3. Turn LP cylinder valve OFF
4. CAUTION: Do not attempt to relight without following all lighting instructions.

### IMPORTANT:

Always shut off the burner valve before closing the tank/gas supply valve. This grill is equipped with a QCC-1 flow-limiting connector which will not reset to allow full gas flow if the supply valve is closed before the burner valve is shut off. If you experience trouble with the grill not heating properly, shut off burner valve, then tank or supply valve. Open lid, wait 5 minutes and follow lighting instructions.

## CARE AND MAINTENANCE

There is very little care and maintenance needed. The Holland Grill is designed and made of materials that will last many years with normal use. Following these instructions will improve the longevity and quality of cooking. To assure safe operation of your Holland Grill, the area for cooking should always be kept free of combustible materials of any type, such as gasoline or other flammable vapors or liquids.

A. Outside of body – This is stainless steel. It can be cleaned easily with warm, soapy water or any stainless steel cleaner.

B. Grid and Drip Pan – The grid is made of high quality stainless steel. The grid should be brushed with a brass, copper, or stainless steel brush immediately after removing food while grill is still warm. The drip pan is stainless steel and can be cleaned with a flat scraper such as a putty knife. CAUTION: The drip pan must be kept clean and free of heavy build-up for grill to perform properly, and to eliminate flare-ups. Do not wash drip pan.

C. Inside Grill – Use warm soapy water to clean this area. Do not allow grease to build up.

D. Drain Pipe and Valve – Both must be kept clear of grease and food particles to allow grease to drain properly from drip pan. This must be done to maintain proper operation of your grill.

E. Food Board – This is made from high density polyethylene, approved by the FDA for direct food contact. Warm soapy water can be used for cleaning. CAUTION: It should not be used as a chopping block, nor should more than 15 pounds be placed on it at any time.

E. General – This grill, like all equipment, will look better and last longer if kept out of weather when not in use. CAUTION: Do not store gas tank in closed areas. See instructions or local gas ordinances for care and storage of propane tanks. When using a cover, never place it on the grill until the entire unit has cooled at least 30 minutes.

Check to be sure all openings into the grill body are free of blockages or debris. Make sure there are no objects or materials blocking the flow of combustion and ventilation air.

When grill is not in use, the gas must be turned off at the supply cylinder.

For outdoor use only. If stored indoors, detach cylinder and leave it outdoors.

Cylinders must be stored outdoors out of reach of children and must not be stored in a building, garage or any other enclosed area.

Check burner venturi behind air shutter screen for insect nests or blockages. Make sure the passage through the burner venturi is not obstructed.

If the burner valve is ever removed for cleaning or replacement, it should be re-installed to the dimension shown below. Measure from the center of the valve handle to the face of the burner air shutter. This assures correct positioning of the orifice in the burner venturi.

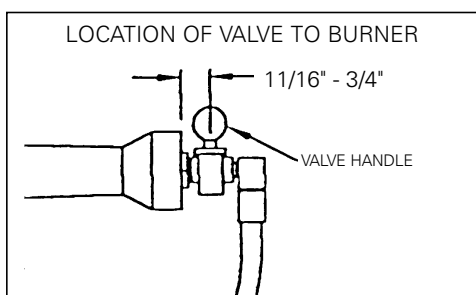

THIS COOKING APPLIANCE IS FOR OUTDOOR USE ONLY AND SHALL NOT BE USED IN A BUILDING, GARAGE OR ANY OTHER ENCLOSED AREA.

## MOVING INSTRUCTIONS

### **CAUTION: NEVER MOVE GRILL WITH BURNER LIT OR WITH WATER IN DRIP PAN.**

A. Moving in your yard or deck: Make sure gas is turned off at burner valve and tank valve. Be sure lid is closed. Lift by the shelf on the end without wheels. Push your grill to desired location, first checking for holes or obstacles that may cause tripping or falling. Make sure grill is level before using.

Moving on trailer or truck: Follow all steps above. Before loading, secure lid closed by tying rope or bungee cord from handle to the cross brace between the leg assemblies. After loading, be sure to tie down securely to prevent damage.

NEVER transport your grill with propane tank connected.

CAUTION: Always secure propane tank tightly to truck or trailer.

## COOKING INSTRUCTIONS

### **ALLOW GRILL TO WARM UP WITH LID CLOSED FOR 20 - 30 MINUTES PRIOR TO COOKING.**

A. It is important to realize cooking on a Holland Grill uses a different process in order for the grill to perform correctly. It is essential that the lid remain closed while grilling. NOTE: Check drip pan valve to make sure it is completely open while grilling

B. If you're looking, you're not cook-

ing! Since this grill uses a combination of direct and indirect heat, the lid must be closed at all times.

C. The Holland Grill has no temperature controls. This means the temperature remains constant; it's simply a matter of timing. If the enclosed cookbook doesn't give the time of an item you wish to cook, refer to most any cookbook for that item to find out how much time is recommended at 400 degrees. Remember, you will probably want to turn the food over once at approximately half the cooking time on short cooking time items.

D. The cooking times we suggest are only that – suggestions. You may want to vary the times as you become used to your Holland Grill.

E. You may cook on the grill in any weather. If the temperature is extremely hot or cold, it will slightly shorten or increase your cooking time.

## GRILLING

1. Steak – T-Bone, 1" thick, Medium doneness: Grill 10 minutes on each side.

2. Chicken – Quarters, average size fryer: Cook skin side up for 30 minutes and skin side down for 30 minutes. Check for doneness. If chicken is completely done, only then, dip or brush on the sauce of your choice. Put back on the grill for approximately 10 minutes longer. NOTE: You may want to repeat this process one or two more times.

3. Pork ribs and chops: 3/4" thick: Grill 10 to 20 minutes on each side. When done, either dip or brush on sauce. Put back on the grill for 5 to 10 minutes longer. Repeat if desired.

## DRY SMOKING

Place Flav-O-Buds or chunks of your favorite dry wood in the stainless steel smoke tray in your Holland Grill. If additional wood is preferred, you can use throw-away aluminum tart pans in the rear corners of the dry drip pan.

Each pan will smoke up to an hour, depending on how many chips or chunks you use in each pan. When finished grilling, throw away wood and use fresh each time you grill.

## STEAMING

To steam foods such as oysters, clams, shrimp, crab legs, etc., follow these procedures:

A. Move the grill to location you plan to use it for steaming. The grill should be level.

B. Open lid and close valve on drain pipe. Fill drip pan with water (1 gallon). NOTE: You will speed process by using hot water. CAUTION: Do not attempt to move grill with water in drip pan.

C. Light grill, following lighting instructions.

D. Close lid. In 20-30 minutes, you should see and feel steam coming from the stack. You are ready to begin the steaming process.

E. Put food you wish to steam on grill and close lid. Most shellfish will cook in 15 - to 25 minutes. You may want to cook yours less or more time after checking.

G. CAUTION: Do not drain water from the grill until it has cooled for at least 30 minutes.

Drain water from pan by placing a large bucket directly under the drain pipe. Open the valve being careful to keep hands away from the water flow. Your grill is now ready to resume regular grilling procedures.

## **PARTS LIST FOR BH-421SS-1 PREMIER HOLLAND GRILL**

Note: All parts numbers listed below are prefixed with the model number BH-421SS-1

### **Contents of Box A:**

100SS	Grill Bottom
201	Stacks (2)
404	Mid Brace Right
405	Mid Brace Left Notched
403	Axle Brace
202SS	Handle Bracket
531	Lighting Clip and Chain (Riveted to #500)
701	Shelves (2 each)
1000	Drip Bucket
500	Stand Tube

### **Contents of Box B:**

200SS	Grill Top
530SS	Grill Bottom Mount
520	Stand Support (nearest front of grill)
521	Stand Support (toward back of grill)
401	Axle
400	Wheels (2 each)
402	Push Nuts (2 each)
510	Stand Foot (2 each)
914SS	Grill Top Stop (right)
915SS	Grill Top Stop (left)
702SS	Shelf Support (2 each right)
703SS	Shelf Support (2 each left)
910	Drain Pipe (threaded both ends)
909	Brass Wheel Valve
800	Tank Top Ring Bracket
101SS	Hinges (2 each)
300SS	Grid, Cooking Surface
600 SS	Drip Pan

The following parts are factory installed in 100SS Grill Bottom, but may be ordered individually:

102	Burner Valve
103	Air Shutter (behind Burner Valve)
104	Insect Screen (Behind Air Shutter)
105	Burner Assembly (less 102, 103 and 104)
106SS	Air Baffle
107	Flame Deflector Plate
108	Regulator and Hose Assembly
109SS	Heat Shield
110	Propane Orifice, drill size #59
116	Natural Gas Orifice, drill size #54

Fasteners: Replacements can be found at most hardware stores.

***If you have a question about the warranty or want to order parts or accessories, please contact your local Holland Grill dealer.***



**The Holland Co., Inc.**  
2501-B Ten Ten Road Apex, NC 27502

Premier 09/97