

This Owner's Manual is provided and hosted by [Appliance Factory Parts](http://www.appliancefactoryparts.com).



HOLMES HM1700 Owner's Manual

[Shop genuine replacement parts for HOLMES HM1700](#)



[Find Your HOLMES Humidifier Parts - Select From 153 Models](#)

----- Manual continues below -----

Holmes®

INFO HOT-LINE: If, after reading this owner's guide you have any questions or comments, please call 1-800-5-HOLMES and a Consumer Service Representative will be happy to assist you.

Cool Mist Humidifier

HM1700



Owner's Guide

FILTER# HWF62
FILTER TYPE: WICK

PLEASE READ AND SAVE THESE IMPORTANT INSTRUCTIONS

PLEASE READ AND SAVE THESE IMPORTANT SAFETY INSTRUCTIONS

When using electrical appliances, basic safety precautions should always be followed to reduce the risk of fire, electric shock, and injury to persons, including the following:

1. Read all instructions before using the appliance.
2. To avoid fire or shock hazard, plug the appliance directly into a 120 V AC electrical outlet.
3. Keep the cord out of heavy traffic areas. To avoid fire hazard, NEVER put the cord under rugs, near heat registers, radiator, stoves, or heaters.
4. DO NOT place humidifier near heat sources such as stoves, radiators, and heaters. Do locate your humidifier on an inside wall near an electrical outlet. The humidifier should be at least 4" away from the wall for best results.
5. NEVER place humidifier in an area where it is accessible to children. NEVER use humidifier in a closed room, particularly where a child may be sleeping, resting, or playing (a closed room may result in excessive humidity).
6. **WARNING:** Do not attempt to refill humidifier without first unplugging the unit from its electrical outlet. Failure to heed this warning may cause personal injury. Be sure to pull the plug and not the cord.
7. Never place anything over moisture outlet when the unit is running.
8. NEVER drop or insert any object into any openings.
9. DO NOT operate any appliance with a damaged cord or plug, after the appliance malfunctions, or if it has been dropped or damaged in any manner. Return appliance to manufacturer for examination, electrical or mechanical adjustment, or repair.
10. Use appliance only for intended household use as described in this manual. Any other use not recommended by the manufacturer may cause fire, electric shock, or injury to persons. The use of attachments not recommended or sold by The Holmes Group, Inc. may cause hazards.
11. DO NOT use outdoors.
12. Always place humidifier on a firm, flat, level surface. A waterproof mat or pad is recommended for under the humidifier. NEVER place it on a rug or carpet, or on a finished floor that may be damaged by exposure to water or moisture.
13. DO NOT allow the Moisture Outlet to directly face the wall. Moisture could cause damage, particularly to wallpaper.
14. Humidifier should be unplugged when not in use.
15. NEVER tilt, move, or attempt to empty unit while it is operating. Shut off and unplug before removing the water tank and moving the unit.
16. This humidifier requires daily and weekly maintenance to operate appropriately. Refer to daily and weekly cleaning procedures.
17. NEVER use detergents, gasoline, glass cleaner, furniture polish, paint thinner, or other household solvents to clean any part of the humidifier.
18. Excessive humidity in a room can cause water condensation on windows and some furniture. If this happens, turn the humidifier OFF.
19. Do not use humidifier in an area where humidity level is in excess of 50%. Use the included hygrometer, or purchase one at your local hardware store or through Holmes, to measure the humidity.
20. DO NOT attempt to repair or adjust any electrical or mechanical functions on this unit. Doing so will void your warranty. The inside of the unit contains no user serviceable parts. All servicing should be performed by qualified personnel only.
21. Never place housing under water flow or immerse in liquids.
22. Do not plug in the cord with wet hands: electric shock could result.
23. Do not pour water in any openings other than the water tank.
24. To prevent damage to surfaces, do not place humidifier under overhanging surfaces.

PLEASE READ AND SAVE THESE IMPORTANT SAFETY INSTRUCTIONS

Consumer Safety Information

Note: This is an electrical appliance and requires attention when in use.

Note: If moisture forms on the walls or windows of the room, turn off the humidifier. The room already has plenty of humidity and additional moisture may cause damage.

Do not block air inlet or outlet.

Cord and Plug Installation Safety Instructions

The length of cord used on this appliance was selected to reduce the hazards of becoming tangled in, or tripping over a longer cord. If a longer cord is necessary an approved extension cord may be used. The electrical rating of the extension cord must be equal to or greater than the rating of the humidifier. Care must be taken to arrange the extension cord so that it will not drape over the countertop or tabletop where it can be pulled on by children or accidentally tripped over.



THIS PRODUCT IS EQUIPPED WITH A POLARIZED AC (Alternating Current) PLUG (a plug having one blade wider than the other). This plug will fit into the power outlet only one way. If the plug does not fit fully into the outlet, reverse the plug. If it still does not fit, contact qualified personnel to install the proper outlet.

DO NOT DEFEAT THE SAFETY PURPOSE OF THIS POLARIZED PLUG IN ANY WAY.

FEATURES - OPERATION

HOW COOL MIST WORKS

Your Holmes Cool Mist humidifier draws dry air through the rear air intake grill area. This air is then passed through a moisture-laden wick filter, which retains the minerals and deposits in the water. The resulting moist air is directed back into the room from the top air grill.

NOTE: This humidification system provides a cool, invisible moisture output. It is normal not to see the mist.

NOTE: A humidity level below 20% can be unhealthy and uncomfortable. The recommended humidity level is between 40%-50%.

PRE-OPERATING INSTRUCTIONS

1. Be sure the humidifier is switched OFF and disconnected from the electrical outlet.
2. Select a location for your humidifier, on a flat surface, about 4" away from the wall. Do not place your humidifier on furniture; a floor location that will not be damaged by moisture is best.
3. Remove the water tank by holding the tank handle and lifting straight upward (see figure 2).
4. Remove the main housing by lifting straight upward. Check to see that the wick filter is properly in place. Replace the humidifier housing.

FILLING THE WATER TANK

NOTE: This humidifier holds about 1 gallon of water in the tank and humidifier base. The humidifier will produce up to 2.0 gallons of moisture over a 24-Hour period, depending on the room humidity and temperature.

1. Be sure the humidifier is switched OFF and disconnected from the electrical outlet.
2. Remove the tank from the base by holding the handle and lifting straight up (see figure 2).
3. Twist off the tank cap located on the bottom of the tank by turning counter clockwise and fill the water tank with cool, fresh water.

Do not fill with warm water as this may cause leaking.

4. After filling the tank, replace the tank cap by firmly turning clockwise and then replace the water tank on the base. The tank will immediately begin to empty into the base.
5. Plug the power cord into a 120V AC electrical outlet.

OPERATING INSTRUCTIONS

1. Move the Humidity Control Knob to the HI position. Move the Humidity Control knob to the LO setting to lower the humidification rate. Allow up to 30 minutes for the filter to fully absorb water and the unit to produce the maximum moisture output.

NOTE: We recommend the use of the hygrometer which you can purchase by calling 1-800-5-HOLMES. A humidity level below 20% can be unhealthy and uncomfortable. The recommended humidity level is between 40% and 50%.

2. When the water tank is empty, and the base is almost empty, you need to refill the tank. The fan will continue to run to help dry the humidifier. Shut off and unplug the unit. Please follow the Daily Cleaning Instructions. Refill the tank as directed in Pre-operating Instructions.
3. Make sure the unit is switched OFF, then plug into the electrical outlet. Turn the power ON.

If you do not plan to use the humidifier for two or more days, make sure any residual water is drained from the water tank, base and wick filter to prevent algae or bacteria growth.

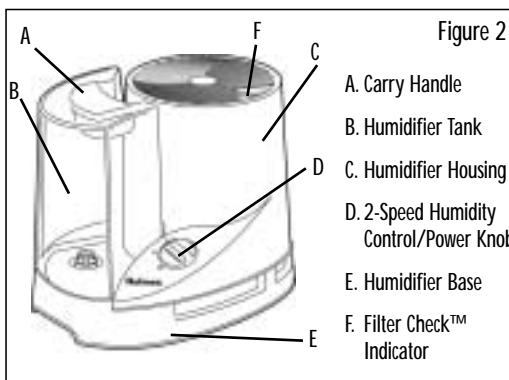
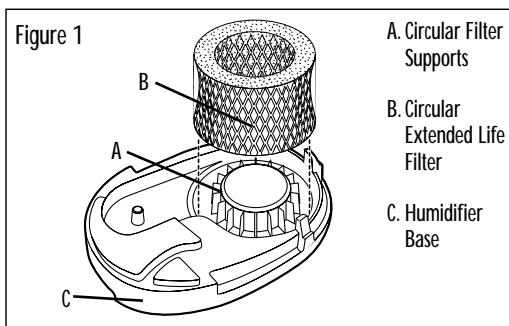

REPLACING THE FILTER CLEANING INSTRUCTIONS - STORAGE

REPLACING THE FILTER

Through normal use, waterborne minerals and sediment become trapped in the wick filter. The harder your water, the greater the amount of minerals in the water, and the more often you will need to change your filter.

You will be able to monitor the life of the filter in your humidifier by checking the Filter Check™ Indicator. When the unit is off, the Filter Check™ Indicator will read in the OFF position. After 60 minutes of use, Filter Check™ Indicator (refer to fig. 3 for close-up of indicator) will move from the OFF position and indicate your filter condition. A brand new filter will register in the blue section reading GOOD filter. After frequent use of your humidifier, the Filter Check™ Indicator will let you know when the filter needs to be changed.

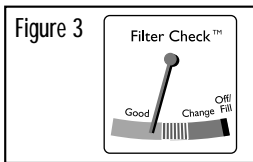

When the needle is in the red (CHANGE) section, this means the proper amount of moisture is not getting into your air due to the excessive minerals and sediment that have become trapped on your filter. At this point, you should replace your filter. It is important to change your filter as indicated to obtain stated performance level.

To replace the filter, follow the steps below.

1. Push the 1 Touch button for 2 seconds to turn the unit OFF and disconnect from the electrical outlet.
2. Remove the tank and main housing to access the base tray.
3. Discard the old filter and follow weekly cleaning instructions.
4. Insert a new filter into the filter support in the base.
5. Replace the main housing and then the tank.
6. Repeat Operating Instruction steps.

It will take about 30 minutes for the humidifier to reach maximum output.

You can obtain a new filter by calling 1-800-5-HOLMES in the USA or by visiting your nearest retailer or authorized service center. This humidifier takes model HWF65 replacement filter.

STORAGE INSTRUCTIONS

If your humidifier will not be in use for two days or more, or at the end of the season follow these instructions.

1. Clean and dry the humidifier thoroughly as per the Weekly Maintenance instructions above.
2. Let the humidifier dry completely before storing. Do not store with water inside the base.
3. Do not store with the reservoir cap in place.
4. Throw away the wicking filter. Do not store with wick filter in place.
5. Store in a cool dry location.

CLEANING AND MAINTENANCE INSTRUCTIONS

Humidifiers provide comfort by adding moisture to dry indoor air. To get the most of the benefit from the humidifier and avoid product failure, follow all maintenance instructions carefully. If the recommended care and maintenance guidelines are not followed, micro-organisms may be able to grow in the water within the humidifier.

Daily Maintenance

1. Be sure the humidifier is switched OFF and disconnected from the electrical outlet.
2. Lift off the tank and the housing of the humidifier. Remove filter and place in sink or tub as the filter will release water when not in the humidifier.
3. Carry the base and the tank to the sink, remove the wick filter, then drain and rinse the base and tank thoroughly to remove any sediment and dirt. Wipe clean and dry with a clean soft cloth or paper towel. (DO NOT use metal cleaning utensils or abrasive cleaners)
4. Put the filter back in the filter supports, replace the housing, then refill the tank with cool tap water as instructed in filling the water tank instructions.

Weekly Maintenance

Remove scale:

1. Repeat steps 1-3 above.
2. Clean the base by partially filling the base with one 8-oz cup of undiluted white vinegar, or by using **Cleanse Clean™ by Holmes**. Let solution stand 20 minutes, clean all interior surfaces with a soft brush.
3. Dampen a cloth with undiluted white vinegar and wipe out entire base to remove scale.
4. Rinse with clean warm water to remove scale and the white vinegar solution before beginning to disinfect the tank.

Disinfect tank:

1. Fill tank with 1/2 teaspoon of chlorine bleach and 1/2 gallon of water.
2. Let the solution stand for 20 minutes, swishing every few minutes. Wet all surfaces.
3. Empty the tank after 20 minutes, and rinse well with water until the bleach smell is gone. Dry with a clean cloth or paper towel.
4. Refill the water tank with cool water; replace the housing and the water tank. Repeat ALL Operating Instructions.

TROUBLESHOOTING

TROUBLE	PROBABLE CAUSE	SOLUTION
Mist output minimal to none.	Filter has not absorbed water. Mineral buildup in tray.	Wait 15 minutes before starting humidifier. Regular cleaning of tray after each use will help keep the unit functioning properly.
	Filter needs to be replaced.	Replace your filter (HWF62) by calling 1-800-5-HOLMES, or visit www.holmesproducts.com .
	Normal	Depending on the humidity setting this may be normal.
Water leaks from tank.	Rubber tank ring is missing or improperly placed.	Remove tank cap then replace or reposition ring.
	Cap not tight enough.	Tighten the cap.
Filter turns brown.	Your filter needs to be changed.	Replace your filter (HWF62) by calling 1-800-5-HOLMES, or visit www.holmesproducts.com .
	Short filter life	In areas with particular hard water your filter will need to be changed more frequently.
Film on tank.	Mineral deposits cause film on tank to buildup.	Use Cleanse Clean™ (S1710), to order call 1-800-5-HOLMES, or visit www.holmesproducts.com
Water cloudy.	Filter needs to be replaced.	Replace your filter (HWF62) by calling 1-800-5-HOLMES, or visit www.holmesproducts.com .
	Using warm water to refill tank.	Only use care products suggested by Holmes and cool water to refill tank.
Very tight tank cap.	Over tightened.	Add liquid soap to cap gasket to ease opening.

REPLACEMENT ACCESSORIES

(see included Humidifier Accessory Form)

- Comfort Check hygrometer/thermometer
Reads humidity and temperature levels
 - Digital HHG175:\$19.99
 - Analog HHG150:\$12.99
 - HWF62 Replacement Filter\$12.99
 - SC1720 Cool Mist Care Pack\$14.99
- (Complete care for your humidifier:
One bottle each of S1705, 1708, 1710)

Individual Bottles also available:

- S1705 Water Treatment\$5.99
 - S1708 Bacteriostat Solution\$5.99
 - S1710 Cleanse Clean™\$5.99
- (plus shipping and handling)

SERVICE INSTRUCTIONS

1. Do NOT attempt to repair or adjust any electrical or mechanical functions on this unit. Doing so will void the warranty.
2. If you have any questions regarding this units operation or believe any repair is necessary, please call 1-800-5-HOLMES to speak with a Consumer Service Representative.
3. If you need to exchange the unit, please return it in its original carton, with a sales receipt, to the store you purchased it.
If you are returning the unit more than 30 days after the date of purchase, please see the enclosed warranty.
4. If you have any other questions or comments, feel free to write us:
The Holmes Group, Inc.
P.O. Box 769
Milford, MA 01757-0769

For your own records, staple or attach your sales receipt to this manual. Also, please take a moment to write the store name/location and date purchased below.

STORE NAME _____
LOCATION: _____
DATE PURCHASED: _____

(STAPLE RECEIPT HERE)

THREE (3) YEAR LIMITED WARRANTY

SAVE THIS WARRANTY INFORMATION

- A. The quality controls used in the manufacture of this Holmes product are to ensure your satisfaction.
- B. This Warranty applies only to the original purchaser of this product.
- C. This Warranty applies ONLY to repair or replacement of any supplied or manufactured parts of this product that, upon inspection by Holmes authorized personnel, proves to have failed in normal use due to defects in material or workmanship. Holmes will determine whether to repair or replace the unit. This Warranty does not apply to installation expenses.
- D. Operating this unit under conditions other than those recommended or at voltages other than the voltage indicated on the unit, or attempting to service or modify the unit, will render this WARRANTY VOID.
- E. **Unless otherwise proscribed by law, Holmes shall not be liable for any personal injury, property or any incidental or consequential damages of any kind (including water damage) resulting from malfunctions, defects, misuse, improper installation or alteration of this product.**
- F. All parts of this Holmes product are guaranteed for a period of 3 years as follows:
 1. Within the first 30 days from date of purchase, the store from which you purchased your Holmes product should replace this product if it is defective in material or workmanship (provided the store has in-stock replacement.)
 2. Within the first thirty six months from date of purchase, subject to the conditions in paragraph H, Holmes will repair or replace the product if it is defective in material or workmanship providing it is returned to Holmes, freight prepaid, with PROOF OF PURCHASE date, together with \$7.00 for handling and return packing/shipping charges.
- G. If you have any problem with this product, please write our Consumer Service Dept., or call, 1-800-5-HOLMES.
- H. **IMPORTANT RETURN INSTRUCTIONS** Your warranty depends on your following these instructions if you are returning the unit more than 30 days after the date of purchase:
 1. Carefully pack the item in its original carton or other suitable box to avoid damage in shipping.
 2. Before packing your unit for return; be sure to enclose:
 - a) your name, full address with zip code and telephone number,
 - b) a dated sales receipt or PROOF OF PURCHASE,
 - c) your \$7.00 check for return packaging, and
 - d) The model number of the unit and the problem you are having. (Enclose in an envelope and tape directly to the unit before the box is sealed.)
 3. Holmes recommends you insure the package (as damage in shipment is not covered by your warranty).
 4. All shipping charges must be prepaid by you (as noted in paragraph F).
 5. Mark the outside of your package:

CONSUMER SERVICE DEPARTMENT
THE HOLMES GROUP, INC.
2 PULLMAN STREET
WORCESTER, MA 01606

SHIPPING AND HANDLING CHARGES: \$7.00

This warranty gives you specific legal rights, and you may have other rights which vary from state to state. The provisions of this warranty are in addition to, and not a modification of, or subtraction from, the statutory warranties and other rights and remedies contained in any applicable legislation. To the extent that any provision of this warranty is inconsistent with any applicable law, such provision shall be deemed voided or amended, as necessary, to comply with such law.