

This Owner's Manual is provided and hosted by [Appliance Factory Parts](#).

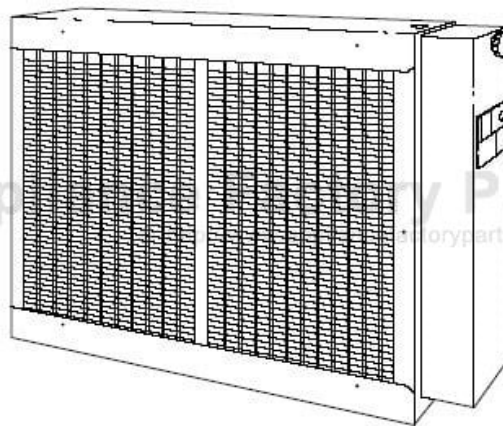

CARRIER 31KAX Owner's Manual

[Shop genuine replacement parts for CARRIER 31KAX](#)



[Find Your CARRIER Air Cleaner Parts - Select From 80 Models](#)

----- Manual continues below -----



Model 31KAX
Electronic Air Cleaner

**A GUIDE TO OPERATING
AND MAINTAINING
YOUR ELECTRONIC**

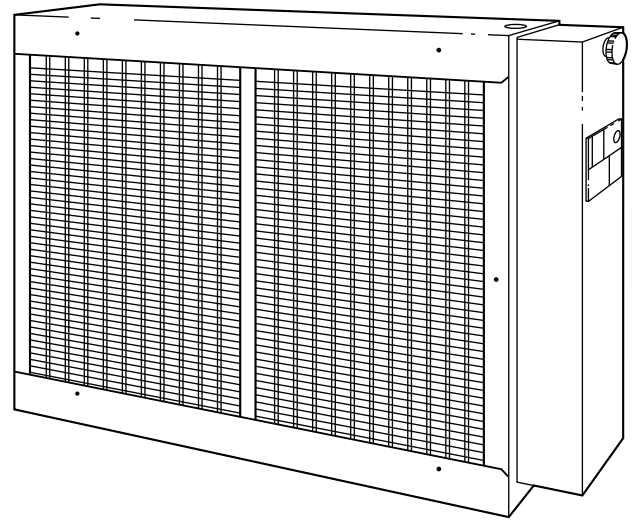

AIR CLEANER

NOTE TO INSTALLER: This manual should be left with the equipment owner.

A BREATH OF SPRING-FRESH AIR . . . YEAR-ROUND

Congratulations on your excellent choice and sound investment in this addition to your home comfort system.

Your electronic air cleaner represents both the latest in engineering development and the culmination of many years of experience from one of the most reputable manufacturers of comfort systems.

Your new unit is among the most energy-efficient and reliable air-filtration products available today. To assure its dependability, spend just a few minutes with this booklet now. Learn about the operation of your electronic air cleaner and the small amount of maintenance it takes to keep it operating at peak efficiency.

With minimal care, your electronic air cleaner will provide you and your family with clean, spring-fresh air — from season to season, and year to year.

YOUR ELECTRONIC AIR CLEANING UNIT

MORE THAN JUST A BREATH OF FRESH AIR

The highest value of clean air is in its contribution to the good health and comfort of you and your family. Additional benefits include potential savings in home heating, cooling, and maintenance costs.

Your new air cleaner will electronically filter out microscopic particles as small as 0.01 micron. At that size, it would take 100,000 particles to cover the head of a pin. Such particles are 500 times smaller than the smallest grains of dust trapped by conventional furnace filters.

Airborne pollutants commonly found in the household are lint, dust, ash, pollen, fungus spores, bacteria, viruses, cooking odors, fumes, and possibly tobacco smoke.

By ridding your home of most of these pollutants, the whole family can breathe fresher, safer air. Moreover, family members suffering from hay fever, asthma, or other respiratory allergies should find exceptional relief. Electronic filtering removes up to 95% of all pollens.

If your home is equipped with central air conditioning or a heat pump, electronic air cleaning can optimize your system's performance by keeping the indoor coil clean. At today's energy rates, the potential savings can be significant.

Electronic air cleaning removes most airborne grease and grime particles before they have a chance to settle. Therefore, walls, windows, draperies, and furnishings stay clean and bright longer. The time and money you save from avoidable cleaning and redecorating projects can be dedicated to more rewarding goals.

HOW YOUR AIR CLEANER WORKS

Contaminated air enters the prefilter (the metal mesh filter) where the larger airborne particles are removed. These include hair, fibers from carpets and drapes, pet hair, and some lint particles. (See Fig. 1a.)

The air then passes through the ionizer/collector cells. The ionizer wires produce positive ions that give airborne particles a positive electrical charge. (See Fig. 1b.)

Opposites attract: Airflow continues, passing between the collector plates. The positively charged particles are attracted and trapped by the negatively charged collector plates. (See Fig. 1c.) These particles continue to cling to the plates until removed by you or your service technician.

Meanwhile, the purified air leaves the air cleaner, refreshingly free of contaminants. This clean air is circulated into your living space by your heating and cooling system providing clean air for breathing into your lungs. (See Fig. 1d.)

DUCT-TYPE ELECTRONIC AIR CLEANER (EAC)

The DUCT-TYPE EAC is well suited for home comfort systems using a gas furnace, split-system air conditioner, or split-system heat pump. If yours is a DUCT-TYPE cleaner, it is installed near your furnace or split-system air handler. See Fig. 2 for typical installations of a duct-mounted air cleaner.

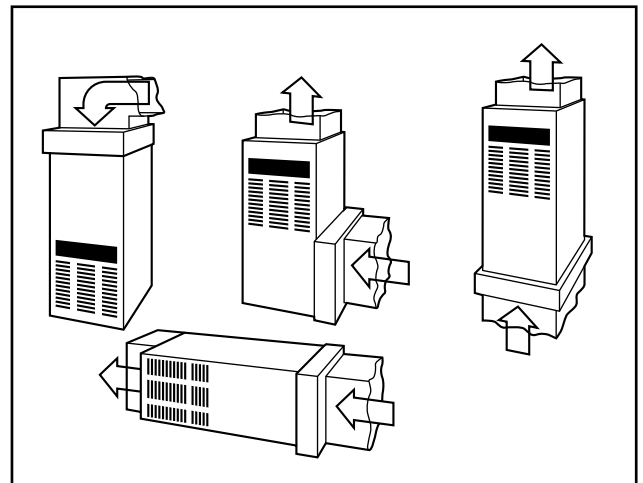

Fig. 2—Typical EAC Installations

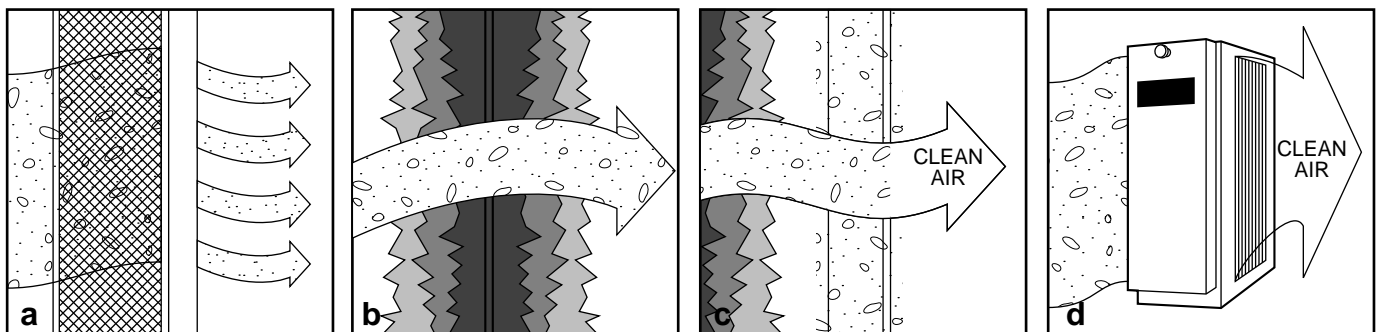

Fig. 1—Air Cleaner Process

OPERATING YOUR ELECTRONIC AIR CLEANER

Your new electronic air cleaner is designed to operate as part of your heating/cooling system. After the cleaner's power switch is turned ON, the cleaner will operate whenever the furnace or air-handler blower is running.

Your electronic air cleaner will perform at maximum efficiency if these recommendations are followed:

- Consider running the heating/cooling system blower continuously—day and night, winter and summer. Continuous blower operation provides for constant air filtration. It may also contribute to greater personal comfort since continuous blower operation minimizes temperature differences throughout the home.

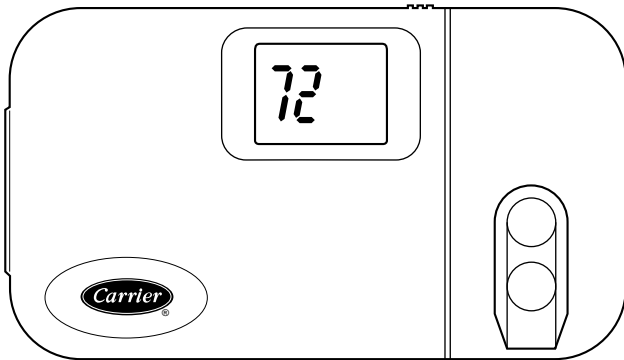

Fig. 3—Thermostat

Furthermore, systems equipped with humidifiers offer the added benefit of having the air humidified during heating.

- Supply-air and return-air grilles should not be blocked. Drapes, furniture, and toys are some of the items commonly found obstructing grilles. Restricted airflow reduces the efficiency of the air cleaner, as well as that of the whole comfort system.
- The electronic air cleaner must be properly maintained.

START-UP PROCEDURES

1. Set the temperature control selector on your indoor thermostat. Choose a setting above current room temperature if heating is required. Set the temperature control selector below room temperature if cooling is needed.
2. Set the FAN mode. When set to AUTO, the air cleaner and system blower will run only while the thermostat operates the heating or cooling section. When the FAN mode is set at the ON position, the air cleaner and blower will run continuously—regardless of whether the cooling or heating section is operating.
3. Select HEAT, COOL, or AUTO.
4. Turn the air cleaner's power switch ON. The power switch for the DUCT-TYPE cleaner is located on the door panel. (See Fig. 4.)

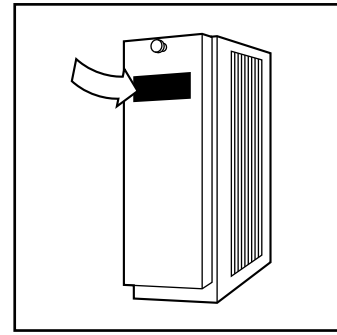
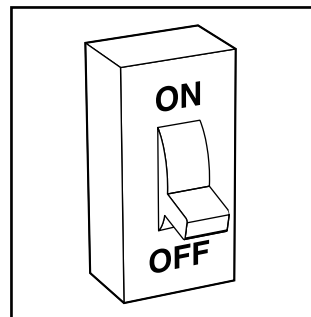

Fig. 4—Power Switch Access

NOTE: The operation light indicates that power is available to the cells. It does not indicate that power is available to the unit.

NOTE: An occasional arcing (snapping) noise is normal during the operation of your air cleaner. Continuous arcing, however, indicates that cleaning is required. Refer to page 4 for directions on cleaning your electronic air cleaner.



ELECTRICAL POWER DISCONNECT PROCEDURE

To disconnect the electrical power to your air cleaner, simply push its power switch to the OFF position. You may continue to operate the rest of your comfort system, or turn the power off according to the manufacturer's specifications.

PERFORMING ROUTINE MAINTENANCE

With the proper maintenance and care, your electronic air cleaner will operate economically and dependably. Maintenance can be accomplished easily by referring to the following directions. However, before performing any maintenance, consider these important safety precautions:

- DISCONNECT ALL ELECTRICAL POWER TO THE AIR CLEANER BEFORE PERFORMING ANY SERVICE OR MAINTENANCE.

NOTE: THERE MAY BE MORE THAN 1 ELECTRICAL DISCONNECT SWITCH.

- ALTHOUGH SPECIAL CARE HAS BEEN TAKEN TO MINIMIZE SHARP EDGES IN THE CONSTRUCTION OF YOUR UNIT, BE EXTREMELY CAREFUL WHEN HANDLING PARTS OR REACHING INTO THE UNIT.

The prefilter and ionizer/collector cells should be checked regularly. Accumulated dirt will need to be removed from these components to maintain efficient air filtration.

Regular inspection allows you to determine the cleaning schedule best suited to your home's operating conditions. The first electronic cleaning of your home may collect more particles over a shorter period than will be normal for future operation.

At minimum, the prefilter and collection cells will need to be cleaned two or three times per year.

CLEANING PROCEDURES

1. Turn OFF all electrical power to the air cleaner and furnace, split-system air conditioner, or split-system heat pump.
2. Open the air cleaner.
 - In a DUCT-TYPE cleaner, rotate the fastener knob counter-clockwise until the door is released. Remove the door by grasping the fastener knob, then lift up and away from the cabinet. (See Fig. 5A.)
 - The DUCT-TYPE prefilter simply slides out. (See Fig. 5b.)

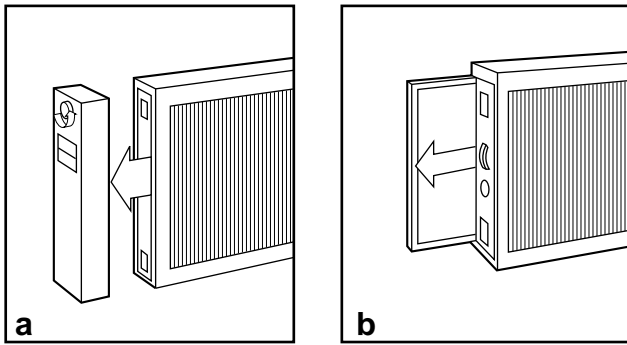
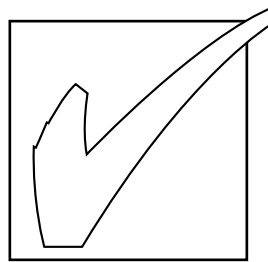

Fig. 5—Opening the EAC

3. Clean the prefilter. Use a vacuum cleaner and soft brush attachment to remove accumulations of dust and lint. If further cleaning is required, wash the prefilter with mild detergent and water (or use pressurized spray from a garden hose or coin-operated carwash sprayer). Rinse. Then drain excess water from the prefilter. Thorough drying is optional.
4. Remove the ionizer/collector cells from the air cleaner cabinet.
 - The DUCT-TYPE cells simply slide out of the cabinet.
5. Wash the ionizer/collector cells either manually or in an automatic dishwasher. Complete drying of the washed cells is optional.
 - For MANUAL WASHING, fill a large container with hot water. Add one-half cup of mild detergent for every 10 gallons of water used. Submerge the cells in the soapy solution and allow to soak for 20 minutes. Rinse with a garden hose or soak in clean, hot water for 10 minutes. Allow excess water to drain from the cells.
 - For a more convenient method, you may wash the cells in an AUTOMATIC DISHWASHER. Place the cells on the lower rack of the dishwasher. Be careful not to damage wires or bend plates. Be sure the airflow direction arrows point up. Add a detergent specifically formulated for automatic dishwashers. Allow the dishwasher to run through a complete wash and dry cycle. Give the cells time to cool before removing from the dishwasher. Allow any excess water to drain from cells.
6. Inspect the cells. Check for broken wires, dislocated wire holders, or bent collector plates. If everything appears to be fine, proceed to the next step. However, if any damage is suspected, contact your servicing dealer for immediate repairs.
7. Reassemble your air cleaner. Insert the prefilter on the entering air side of the air cleaner. Install the ionizer/collector cells. Be sure airflow direction arrows point away from where the prefilter is positioned.

8. Turn on the electrical supply power to your furnace, split-system air conditioner, or split-system heat pump.

NOTE: No drying period is needed for the prefilter and cells before reassembly. However, the indicator lamp will not glow and the unit will not begin to operate until thoroughly dry.



- Check the setting on your indoor thermostat. The FAN should be set at ON for continuous blower and air cleaner operations, or AUTO if you wish the blower and cleaner to function only when heating or cooling is required.
- Check the power switch on your electronic air cleaner. Be sure it is

ON and the power indicator lamp is glowing.

- Check the main power disconnect switch. Verify that the circuit breakers are ON or that fuses have not blown. If you must reset breakers or replace fuses, do so only once. Contact your servicing dealer for assistance if breakers trip or fuses blow a second time.
- Check air cleaner components. Check for proper orientation of the prefilter and ionizer/collector cells. The prefilter must be on the incoming-air side of the cells. Arrows stamped on the sides of the cells must point in the direction of airflow. The prefilter and cells must be clean and dry.
- Check for sufficient airflow. Check the air cleaner's prefilter and ionizer/collector cells for any accumulation of dirt. Check for blocked return-air or supply-air grilles. Be sure grilles are open and unobstructed.

If your comfort system still fails to operate, contact your servicing dealer for troubleshooting and repairs. Specify your apparent problem, and state the model and serial numbers of your equipment.

With this information, your dealer may be able to offer helpful suggestions over the phone, or save valuable time through knowledgeable preparation for the service call.

REGULAR DEALER MAINTENANCE

In addition to the routine maintenance that you perform, your electronic air cleaner should be inspected regularly by a properly trained service technician. The inspection (preferably each year, but at least every other year) should include the following:

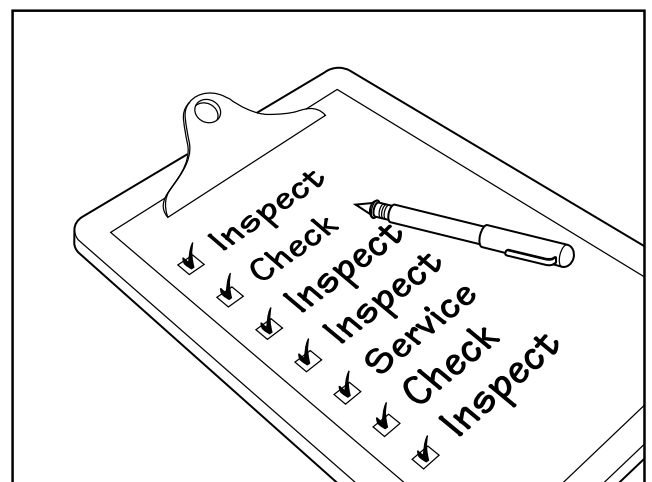

- Routine inspection of the prefilters and ionizer/collector cells. Clean, if necessary.
- Routine inspection of ionizer wires. Service should include realignment or replacement as required.
- A check of all electrical wiring and connections.
- Operational check of the complete comfort system to determine actual working condition. Necessary repair and/or adjustment should be performed at this time.

Your servicing dealer may offer an economical service contract that covers seasonal inspections. Ask for further details.

Record the model and serial numbers of your new electronic air cleaner in the spaces provided below. This information, along with the other ready-reference facts requested below, may be required if you should ever need information or service.

Model No. _____

Serial No. _____

Date Installed _____

Dealer Name _____

Address _____

City _____

State _____ Zip _____

Telephone _____



TO OBTAIN INFORMATION ON PARTS: Consult your installing dealer or classified section of your local telephone directory under the "Heating Equipment" or "Air Conditioning Contractors & Systems" headings for dealer listing by brand name. Have available the Model No., Series Letter & Serial No. of your equipment to insure correct replacement part.

Carrier Corporation • Syracuse, New York 13221

Manufacturer reserves the right to discontinue, or change at any time, specifications or designs without notice and without incurring obligations.