

This Owner's Manual is provided and hosted by [Appliance Factory Parts](http://www.appliancefactoryparts.com).

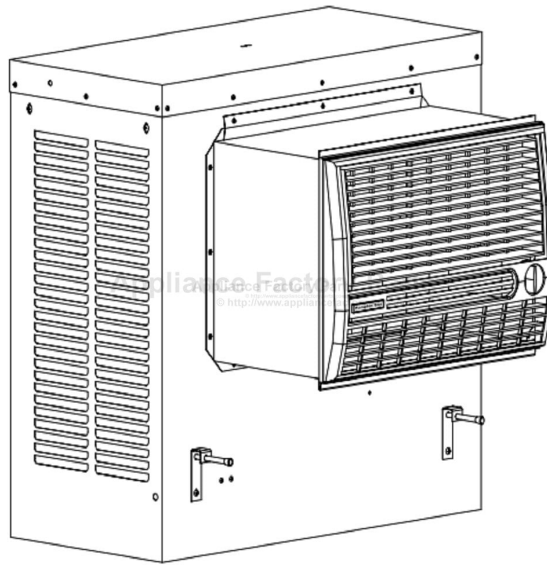

HAMPTON BAY HB30 Owner's Manual

[Shop genuine replacement parts for HAMPTON BAY
HB30](#)



[Find Your HAMPTON BAY Dehumidifier Parts - Select From 59 Models](#)

----- Manual continues below -----



OWNER'S MANUAL

WINDOW EVAPORATIVE AIR COOLER

MODEL: HB30

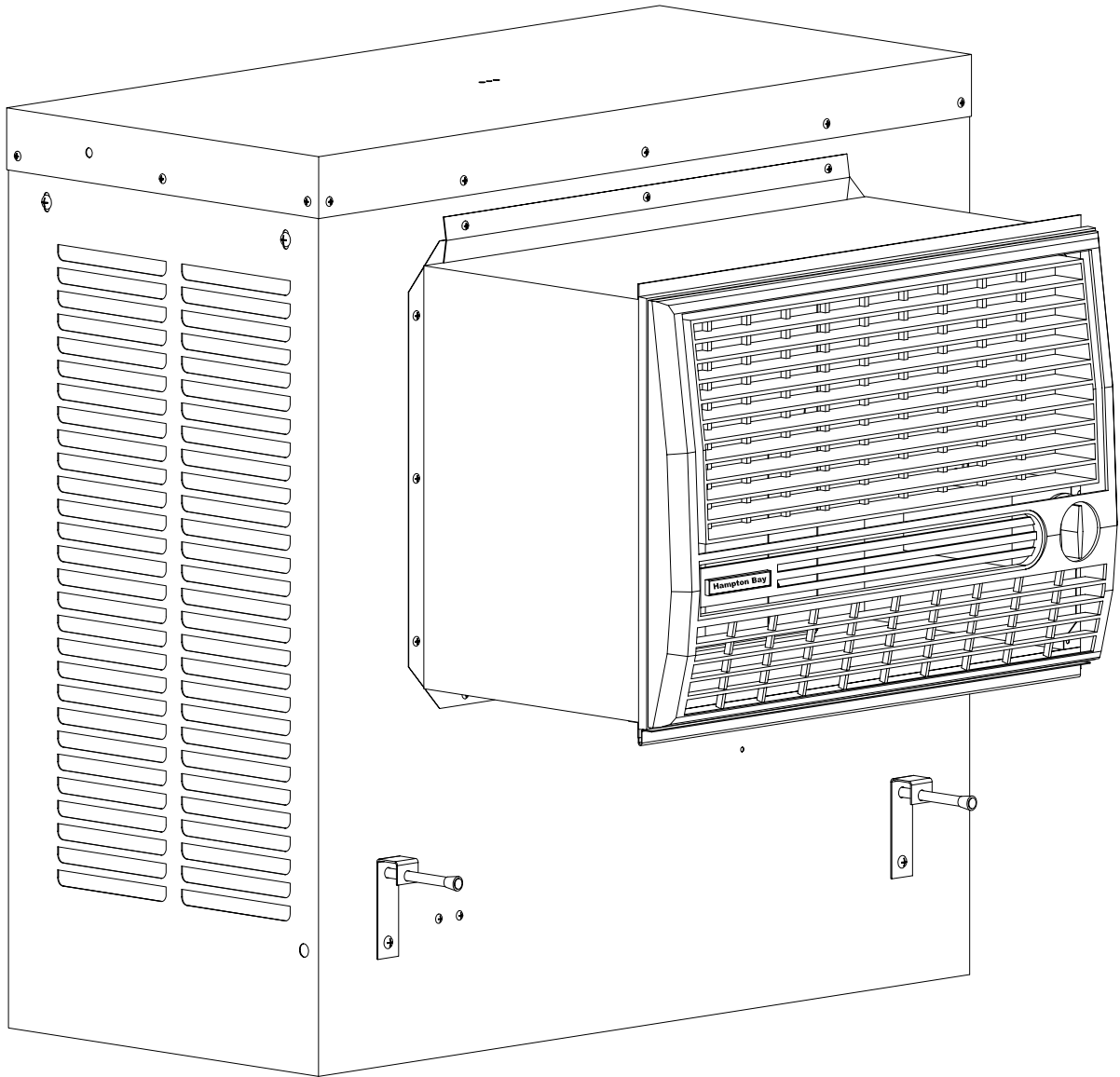

READ AND SAVE THIS INSTRUCTION MANUAL

Date purchased: _____
Purchased from: _____

P/N 71050
REV. 1/03

Evaporative Cooling

Evaporative cooling uses the principle of evaporation to lower the air temperature. Hot, dry air is passed through wetted filters and is converted to refreshingly cooled air. The HB30 makes the best use of the evaporative process by controlling the flow of water, spreading the water evenly over the filters, and keeping a steady stream of cooled air entering your home. It is exhausted out open windows or doors, carrying heat, smoke and odors along with it. The HB30 is 80% less costly to operate than refrigerated air conditioners.

Cautions: To prevent harm to yourself and others, and to avoid damage to your cooler, PLEASE follow these guidelines.

When Installing	When Operating	When Servicing
Make sure that unit is installed on a sound structure that will support the full operating weight of the cooler. See page 4.	Make sure that circuit cooler is plugged into is equipped with a (slow blow) breaker large enough to support the full amperage of the cooler.	Always Unplug the cooler before attempting service of any kind.
Before attempting to hang the cooler in the window, remove the louver to reduce weight.	To reduce the risk of fire or electrical shock, DO NOT use this fan with any Solid-state speed control device.	Be sure to disconnect unit from power source before servicing. If not, it can be turned on from inside the house and start unexpectedly.
Do Not connect power to cooler before installation is complete.	This cooler is equipped with an automatic thermally protected motor. If it shuts off on its own for any reason, it can restart without warning.	If the motor shuts off because of thermal overload, check into the problem immediately. If allowed to continue, permanent damage will occur.

MOUNTING

To install this cooler, the following tools are required:

- Adjustable wrenches
- Screwdrivers
- Electric drill
- 3/16" drill bit
- Level

1. Cut the Side Sealer Channels so that two of them will span the window when butted together. Place two of the channels on the bottom duct flange as shown.
2. Place the Cooler in the center of the window with the bottom duct flange resting against the sill.
3. Pull out the Spacer-Rods so as to allow the Rubber Feet to rest against the side of the house. Tighten the Adjustment Screws.
4. Lower the window to rest on top of the duct behind the top duct flange.
5. Fasten a stop above the inside window sash to prevent the window from being raised. Raising the window may cause the cooler to fall.
6. Adjust the Spacer-Rods to level the cooler. This will ensure proper water flow to the pads.
7. Install the Chain Supports (**Not Included**).
 - a. Drill pilot holes in the window frame, 3 feet above the top of the duct and the width of the cooler apart. Install the Screw-Hooks in these pilot holes to the full depth of the thread.
 - b. Hook one end of each Chain over each Screw-Hook.
 - c. Place S-Hooks in the holes at the top-rear of the cooler.
 - d. Place the opposite end of the S-Hooks in the free end of each Chain. Make sure the chains are taut, but not so tight they pull the bottom of the cooler away from the wall.

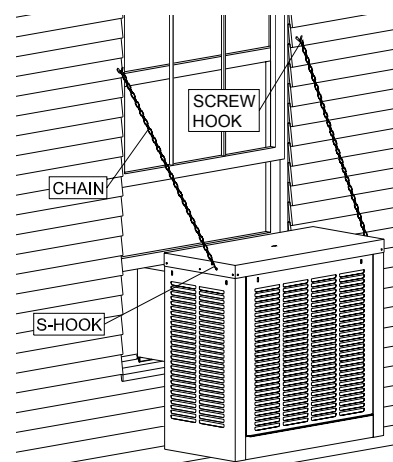
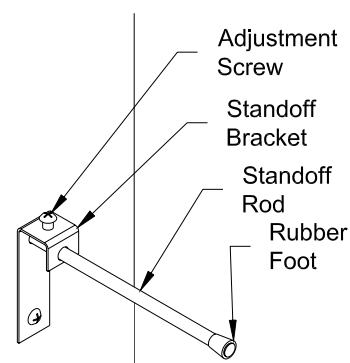
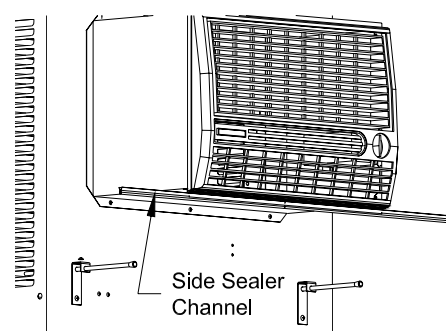

8. Install the Side Sealer Panels. These panels are the correct height, but need to be trimmed to fit the width of your window. Trim the panels so that they reach from the window frame to the side of the duct. Slide the panels in the channels you placed on the bottom duct flange. Install the remaining Side-Sealer Channels over the top duct flange and the Side-Sealer Panels.

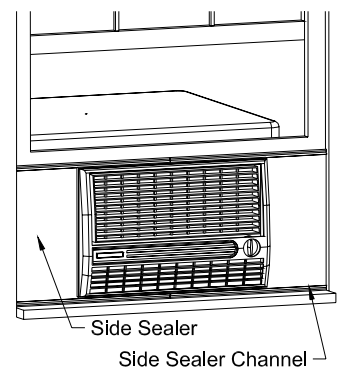

INSTALL OVERFLOW AND DRAIN

1. Slide the Rubber Washer over the Drain Bushing and push through the hole in the bottom of the cooler from the topside.
2. Secure the Drain Bushing from beneath the pan with the Lock Nut. Make sure the Rubber Washer does not twist while tightening, which could cause it to leak. **DO NOT OVERTIGHTEN.**
3. Thread the Overflow Tube into the Drain Bushing and **HAND TIGHTEN.**
4. If leakage occurs after Reservoir is full, retighten the Overflow Pipe until leaking stops. A small amount of silicone caulk may be used if necessary.

FLOAT VALVE INSTALLATION

1. Place the threaded portion of the Float Valve through the hole provided in the Float Bracket (inside unit) as shown.
2. Slip the Fiber Washer over the threaded portion of the float and secure with the Ring Nut. Be sure the Float does not turn while you are tightening the nut.

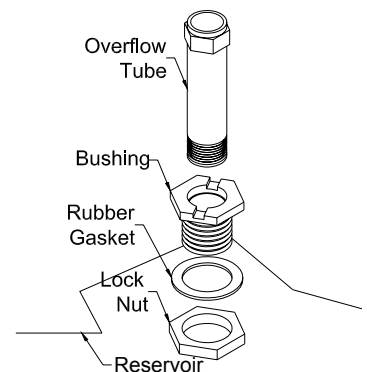

WATER LINE CONNECTION

1. Find the closest outside water faucet, and install a Water Connection Kit (not included with cooler) as shown. If an exterior faucet is not available, locate the closest cold water pipe and install a saddle valve assembly.

2. Route tubing into cooler. Place Compression Nut and Ferrule over end of tubing. Insert the tubing into float valve and tighten Compression Nut to secure.

NOTE: Over tightening a compression fitting will cause that fitting to leak. It is best to secure the connections, turn on the water, and then snug the fitting until leaking stops.

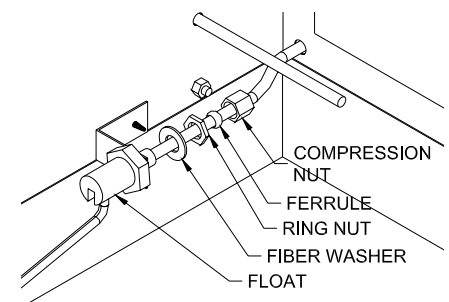

ADJUSTING WATER LEVEL AND FLOAT VALVE

1. To adjust water level, bend the float valve rod.
2. Check all water connections for leaks.
3. Make sure the Float Valve cuts off completely when the desired water level has been reached ($\frac{1}{2}$ " to $\frac{3}{4}$ " below top of Overflow Tube). If the float does not stop the water completely, the water level will rise and run out the Overflow Tube.
4. Double-check the Overflow Tube for leaks.

START UP

1. Plug in the electrical cord to a standard grounded receptacle. Be sure the Circuit Breaker protecting the receptacle is of sufficient size.
2. Open windows in rooms where you want cooling to be directed.
3. Turn the cooler to the High Fan position. Observe the amount of air being delivered. Note: on cool nights (or days) or when the humidity level is high, the fan positions may be used to for ventilation purposes.
4. Turn the cooler to the Low Fan position. This should significantly reduce the amount of air being delivered.
5. Turn the cooler to the Pump Only position. The pump should run and not the fan. Check to see that water is flowing from all three Water Trays.
6. Turn the cooler to the High Cool position. Check to see that all three Pads are wetting evenly with no dry patches. The Pads may take up to 20 minutes to wet fully. If the Pads have dry patches, you can adjust the level of each Water Tray by screws on each end.
7. Adjust window openings to achieve desired cooling level.

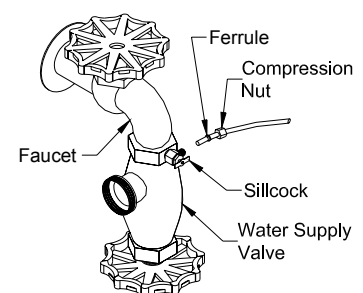

MAINTENANCE

1. Once a month during cooling season, inspect your cooler for leaks, blocked water lines and excessive residue build-up on the pads.
2. At the end of the season, drain the reservoir. Remove the drainpipe and let water and dirt pass through the drain fitting.
3. Lime build-up can occur in the water reservoir and on louvers. Clean this off at least once per season. If any rust or bare metal spots occur on the cabinet or louver, the metal should be sanded, primed and painted with a good quality paint.
4. If freezing weather occurs in your area, it is best to shut off the water supply at the source and drain the supply line to the cooler.
5. A canvas cooler cover is recommended to prevent rain and weather from damaging your cooler.

DO NOT GET WATER ON MOTOR OR PUMP MOTOR

NOTE: Depending on the mineral content of the water or the amount of airborne dust in your area, you may need to replace filter pads during the season.
 It is best to replace filter pads again at the end of the season.
 Old filter pads soak up lime and salts, which can rust the louvers and the cabinet during the winter months.

TO REPLACE PADS

1. Remove louver (U) from cooler.
2. Unhook pad holders (V) at the sides of the louver. Unhook pad holders above and below side pads inside cooler.
3. Remove old pads (W) and discard.
4. Tuck in rear pad to make sure hot air can not by-pass filter.
5. Place pad holders over new pad and hook into place.
6. For the side pads, center pad over louver openings in cabinet, hook pad holder below pad, tilt into place and hook at top.

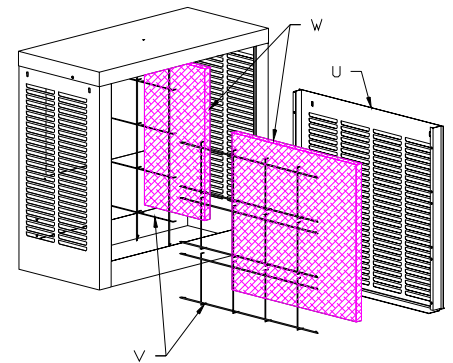

WIRING DIAGRAM

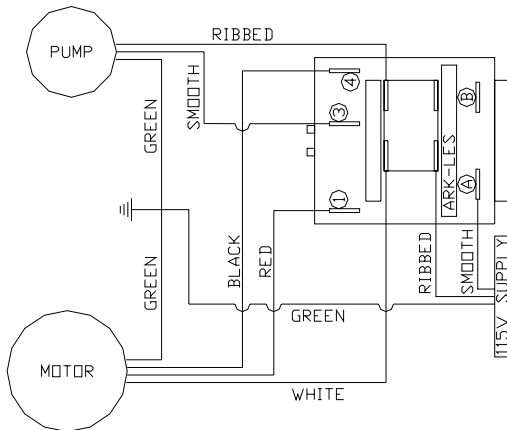

TROUBLE SHOOTING

Problem	Cause	Remedy
Motor cycles on and off	<ul style="list-style-type: none"> • Circuit breaker not large enough 	<ul style="list-style-type: none"> • Consult a licensed electrician
Fails to start	<ul style="list-style-type: none"> • No electrical power • Circuit breaker tripped or fuse blown 	<ul style="list-style-type: none"> • Check all electrical connections and cords • Reset circuit breaker or replace fuse
Water draining from overflow	<ul style="list-style-type: none"> • Float improperly adjusted 	<ul style="list-style-type: none"> • Adjust float
Blower vibrates excessively or rattles	<ul style="list-style-type: none"> • Blower wheel out of balance or out of alignment • Debris in blower housing 	<ul style="list-style-type: none"> • Replace the blower wheel • Clear debris
Not cooling	<ul style="list-style-type: none"> • Blocked water lines • Windows opened too little or too much. • Uneven pad wetting • Pump clogged or failed • Pads plugged with dirt and water deposits 	<ul style="list-style-type: none"> • Check incoming water line, float and water distributor for blockages. Clear. • Adjust window openings • Level water trays; check for blocked water slots in water trays • Clean pump or replace • Replace pads

Replacement Parts
Repuestos
HB30

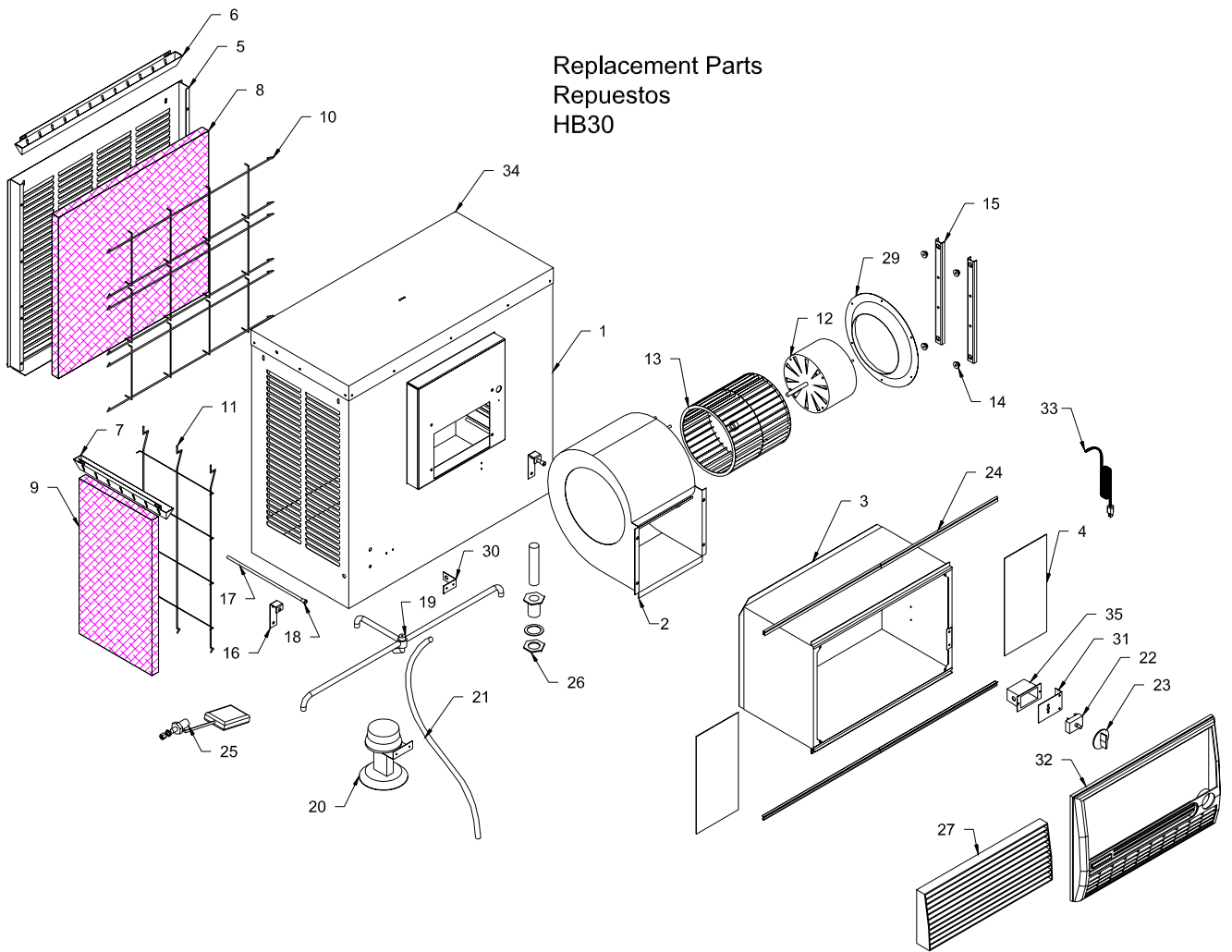

Item	Description	Qty	Part No.	Item	Description	Qty	Part No.
1	Cabinet	1	70422	19	Water Distributor	1	70376
2	Blower	1	70366	20	Pump	1	71057
3	Duct	1	70371	21	Water Hose	1	598454
4	Side Sealer	2	70618	22	Switch	1	524299
5	Louver	1	70375	23	Knob	1	524300
6	Water Tray-Back	1	504268	24	Side Sealer Channel	4	70656
7	Water Tray-Side	2	504266	25	Float Valve	1	502389
8	Filter-Back	1	71053	26	Water Overflow Kit	1	506667
9	Filter-Side	2	71052	27	Sub-Vent Assembly	1	70741
10	Pad Retainer-back	1	504255	28	Louver Assembly**	1	71054
11	Pad Retainer-Side	2	70415	29	Inlet Ring	1	70425
12	Motor	1	70423	30	Float Bracket	1	70373
13	Blower Wheel	1	70424	31	Switch bracket	1	70798
14	Motor Mount Bushing	4	589040	32	Grille Frame	1	70658
15	Motor Mount	2	70431	33	Cord	1	70414
16	Stand-off Bracket	2	70417	34	Top	1	70851
17	Stand-off Rod	2	504341	35	Electrical box	1	524342
18	Rubber Foot	2	524344	36	Grille assembly*	1	71055

* Includes items 27 & 32. ** Includes items 5, 6, 8 & 10.

Instructions to Convert Unit to Vertical Duct Configuration

1. Remove the 12 screws holding the Duct in place.
 2. Turn the Duct 90 degrees counter-clockwise and slide flange under top as shown.
 3. Insert 3 screws at the bottom of the duct.
 4. Place the Duct Mount Strips over the side Duct Flanges and insert 3 screws each into the holes provided.
- Proceed with the installation as normal. The Side Sealer Channels will go on the same flanges as for a horizontal duct. You may use the Side Sealers provided to close off the window above your cooler's duct.

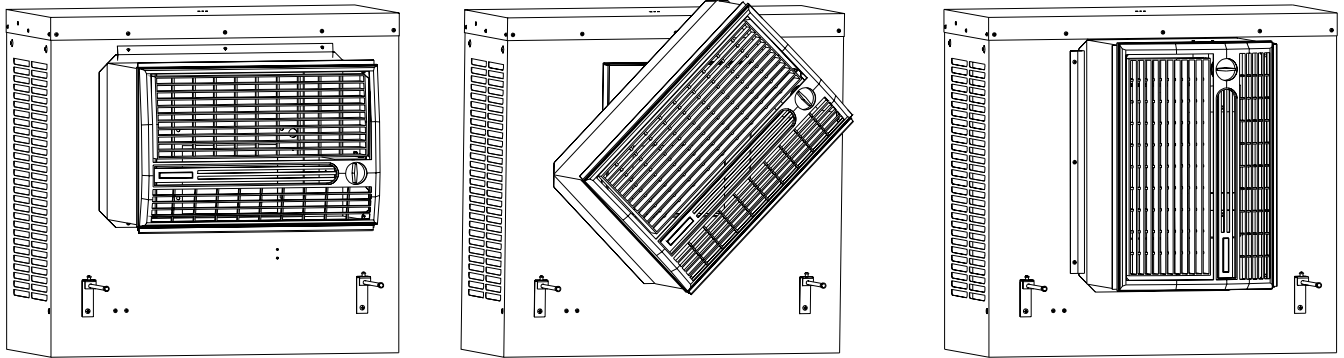

LIMITED WARRANTY

This warranty is extended to the original purchaser only. It does not cover damages incurred during shipping or through accident, neglect, or abuse by the owner. Essick Air Products does not authorize any person or representative to assume any other or different liability in connection with this cooler.

TERMS AND CONDITIONS OF WARRANTY

The **BOTTOM PAN** is guaranteed against leakage due to rusting out for **Five Years**. All other original parts provided by Essick Air Products are warranted against defects in material or factory workmanship for One Year.

EXCLUSIONS FROM THE WARRANTY

Essick Air Products is not responsible for incidental or consequential damage resulting from any malfunction.

Essick Air Products is not responsible for any damage occurring from the use of water softeners, chemicals, descale material, or if a higher horsepower motor than what Essick Air Products recommends is used in the unit.

Essick Air Products is not responsible for the cost of service calls to diagnose cause of trouble, or labor charge to repair and/or replace parts.

HOW TO OBTAIN SERVICE UNDER THIS WARRANTY

Contact the Dealer where you purchased the evaporative cooler. If for any reason you are not satisfied with the response from the Dealer, contact Customer Service Department: Essick Air Products inc.; 5800 Murray Street, Little Rock, Arkansas 72209. 1-501-562-1094.