

This Owner's Manual is provided and hosted by [Appliance Factory Parts](#).



HONEYWELL 40100 Owner's Manual

[Shop genuine replacement parts for HONEYWELL
40100](#)



[Find Your HONEYWELL Air Cleaner Parts - Select From 215 Models](#)

----- Manual continues below -----

Honeywell

enviracaire® PLATINUM AIR™ AIR PURIFIER

40100, 40200 Series

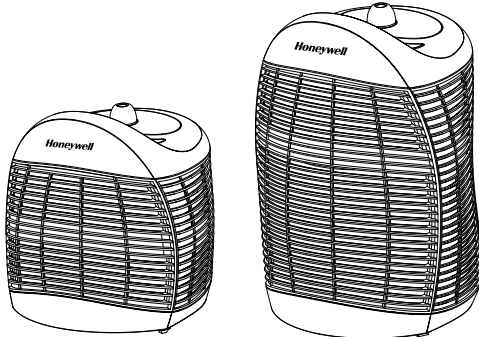

IMPORTANT **SAFEGUARDS**

READ AND SAVE THESE SAFETY INSTRUCTIONS BEFORE USING THIS PRODUCT.

When using electrical appliances, basic precautions should always be followed to reduce the risk of fire, electric shock, and injury to persons, including the following:

1. Read all instructions before operating the air purifier.
2. Place the air purifier where it is not easily knocked over by persons in the household.
3. Always turn the air purifier to the **OFF** position and unplug from the wall outlet when not in use.
4. To disconnect the air purifier, first turn control to the **OFF** position, grip the plug and pull it from the wall outlet. Never pull by the cord.
5. Do not use any product with a damaged cord or plug or if product malfunctions, is dropped or damaged in any manner. Keep the cord away from heated surfaces.
6. Do not use the air purifier outdoors.
7. Never use the air purifier unless it is fully assembled.
8. Do not run power cord under carpets, and do not cover with throw rugs. Arrange cord such that it will not be tripped over.

9. Do not use the air purifier where combustible gases or vapors are present.
10. Do not expose the air purifier to rain, or use near water, in a bathroom, laundry area or other damp location.
11. The air purifier must be used in its upright position.
12. Do not allow foreign objects to enter ventilation or exhaust opening as this may cause electric shock or damage to the air cleaner. Do not block air outlets or intakes.
13. Locate the air purifier near the outlet and avoid using an extension cord.
14. This appliance has a polarized plug (one blade is wider than the other). To reduce the risk of shock, this plug is intended to fit only one way in a polarized outlet. If the plug does not fit fully in the outlet, reverse the plug. If it still does not fit, contact a qualified electrician. **DO NOT** attempt to defeat this safety feature.
15. A loose fit between the AC outlet (receptacle) and plug may cause overheating and a distortion of the plug. Contact a qualified electrician to replace loose or worn outlet.
16. Do not sit, stand or place heavy objects on the air purifier.
17. Disconnect power supply before servicing.

WARNING: TO REDUCE THE RISK OF FIRE OR ELECTRIC SHOCK, DO NOT USE THIS AIR CLEANER WITH ANY SOLID-STATE SPEED CONTROL DEVICE.

YOUR AIR PURIFIER:

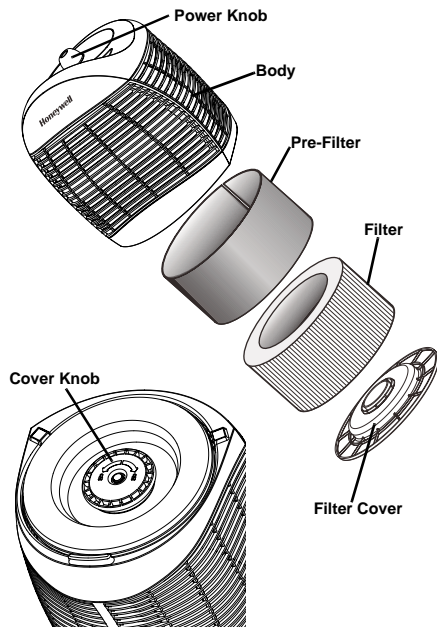

SET-UP:

- Select a firm, level and flat location. For proper air flow, locate the unit at least 3 feet (1 M) from any wall or furniture.
- When operating, large volumes of air are drawn toward the air purifier. Surrounding areas should be cleaned and/or vacuumed frequently to prevent build-up of dust and other contaminants. This may also help prolong the life of both the pre-filter and filter. If the unit is placed on a light colored carpet, a small mat or rug should be used underneath to prevent permanent staining. This is especially important in homes with contamination from smoking or fireplaces.

INSTALL PRE-FILTER:

The Pre-Filter is supplied in the box with the air purifier. It is wrapped to ensure purity.

To install the Pre-Filter:

- Turn-off and unplug the air purifier.

- Remove the protective wrap from the Pre-Filter.
- Loosen the Cover Knob and remove the Filter Cover.
- Place the Filter on a flat surface. Shape it in an approximate circle.
- Wrap the Pre-Filter around the outside of the Filter and secure it with the supplied fasteners. See Fig 1.
- Place both back into the air purifier body and secure the Filter Cover.

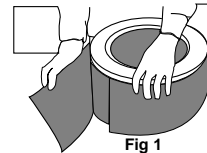

OPERATION:

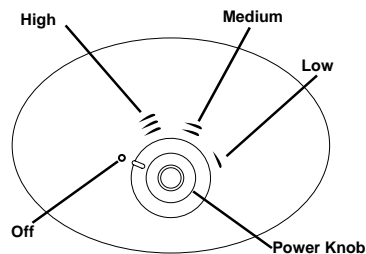

- Ensure the air purifier is plugged into a working electrical outlet and the Power Knob is **OFF**.
- Start and run the air purifier on **High** for several minutes and then rotate the Power Knob to the desired cleaning level.

It is recommended you run your air purifier 24 hours a day to ensure continuous cleaning. Portable air purifiers are more effective in rooms where all doors and windows are closed.

WHEN TO REPLACE THE FILTERS?

These replacement intervals are intended as guidelines only. Useful life expectancy of any filter media is dependent upon the concentration of contaminants going through the system. High concentrations of contaminants such as dust, pet dander and smoking will reduce the useful life of the filters. **NOTE:** Filters are not washable.

PRE-FILTER:

- At least every 3 months. The pre-filter should be replaced more frequently in areas with high concentrations of dust, pet dander or smoking.
- *We strongly recommend operating your Air Purifier with the pre-filter installed in order to prolong the life of the Filter.*

- Use the pre-filter Change Reminder labels provided. Peel off the label and write-in the month and when the filter needs to be changed. Place the label on the air purifier.

FILTER:

- Depending upon operating conditions, the Filter should be replaced every 1 to 3 years (1-year for heavy usage, 2-years for normal usage, 3-years light usage).

CLEANING & STORAGE:

We recommend that you clean the air purifier at least once a month and before extended storage. Use only a dry cloth to wipe the external surfaces of the air purifier. **DO NOT USE WATER, WAX POLISH, OR ANY CHEMICAL SOLUTION.**

If your Air Purifier will not be used for more than 30 days, we recommend:

- Remove the Filter and Pre-Filter from the unit.
- Discard the Pre-Filter.
- Wrap the Filter in an air tight plastic bag.

FREQUENTLY ASKED QUESTIONS:

- *My Air Purifier is starting to make noise and the air output is less. What's wrong?*
 - The filters may be dirty. High amounts of contaminants can block the pores in the filters and stop the air from moving through them. Replace the Pre-Filter first. If this does not help, replace the Filter itself.
- *How long should I run my Air Purifier?*
 - For best results, you should operate your Air Purifier 24 hours a day. This unit will be more effective when doors and windows are closed.
- *Why do I need to use the Pre-Filter?*
 - The Pre-Filter helps to control odors and traps larger particles that can quickly clog the pores of the Filter itself. A clean Pre-Filter will extend the working life of the Filter.
- *Can I wash my filters?*
 - No. Washing the filters will destroy them.

For more troubleshooting tips, visit our website at: www.honeywellconsumerproducts.com

NOTE: IF YOU CONTINUE TO EXPERIENCE A PROBLEM, PLEASE RETURN THE AIR PURI-

FIER TO THE PLACE OF ORIGINAL PURCHASE OR SEE YOUR WARRANTY. DO NOT ATTEMPT TO OPEN THE AIR PURIFIER YOURSELF. DOING SO MAY VOID YOUR WARRANTY AND CAUSE DAMAGE TO THE PRODUCT OR PERSONAL INJURY. IF YOU HAVE ANY QUESTIONS REGARDING THE AIR PURIFIER, PLEASE CALL OR WRITE:

Honeywell
 Consumer Relations Department
 250 Turnpike Road
 Southborough, MA 01772
 Toll Free 1-800-332-1110
 E-mail: honeywell@protocolusa.com

ACCESSORIES, REPLACEMENT FILTERS:

To order a universal Pre-Filter (38002) or replacement Filter (40190), visit our website at:

www.honeywellconsumerproducts.com.

5 YEAR LIMITED WARRANTY

You should first read all instructions before attempting to use this product. Register your product on-line at www.honeywellconsumerproducts.com or complete and return the Customer Response Card within 7 days.

- A. This 5 year limited warranty applies to repair or replacement of product found to be defective in material or workmanship. This warranty does not apply to damage resulting from commercial, abusive, unreasonable use or supplemental damage. Defects that are the result of normal wear and tear will not be considered manufacturing defects under this warranty.
- **HONEYWELL IS NOT LIABLE FOR INCIDENTAL OR CONSEQUENTIAL DAMAGES OF ANY NATURE. ANY IMPLIED WARRANTY OF MERCHANTABILITY OR FITNESS FOR A PARTICULAR PURPOSE ON THIS PRODUCT IS LIMITED IN DURATION TO THE DURATION OF THIS WARRANTY.** Some jurisdictions do not allow the exclusion or limitation of incidental or consequential damages or limitations on how long an implied warranty lasts, so the above limitations or exclusions may not apply to you. This warranty gives you specific legal rights, and you also may have other rights which vary from jurisdiction.

tion to jurisdiction. This warranty applies only to the original purchaser of this product from the original date of purchase.

- B. At its option, Honeywell will repair or replace this product if it is found to be defective in material or workmanship. Defective product should be returned to the place of purchase in accordance with store policy. Thereafter, while within the warranty period defective product may be returned to Honeywell.
- C. This warranty does not cover damage resulting from any unauthorized attempts to repair or from any use not in accordance with the instruction manual.
- D. Return defective product to Honeywell Consumer Products with a brief description of the problem. Include proof of purchase and a \$10 US/\$14.50 CAN check or money order for handling, return packing and shipping charges. Please include your name, address and daytime phone number. You must prepay shipping charges. Send to:

In the USA:

Honeywell
Attn: Returns Department
4755 Southpoint Drive
Memphis, TN 38118 USA

In Canada:

Honeywell
Attn: Returns Department
510 Bronte Street S.
Milton, ON L9T 2X6 Canada