

This Owner's Manual is provided and hosted by [Appliance Factory Parts](http://www.appliancefactoryparts.com).

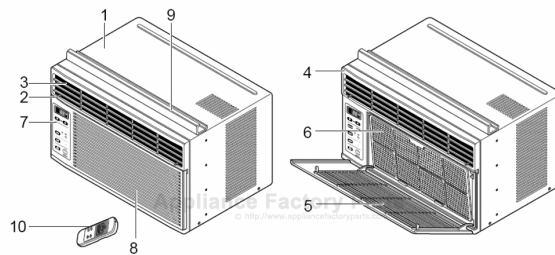

QUASAR HQ-2052UH Owner's Manual

**Shop genuine replacement parts for QUASAR
HQ-2052UH**



- | | |
|-----------------------------|-----------------------|
| 1. CABINET | 6. AIR FILTER |
| 2. HORIZONTAL AIR DEFLECTOR | 7. CONTROL BOARD |
| 3. COOL AIR DISCHARGE | 8. AIR INTAKE |
| 4. FRONT GRILLE | 9. UPPER GUIDE |
| 5. INLET GRILLE | 10. REMOTE CONTROLLER |

[Find Your QUASAR Air Conditioner Parts - Select From 22 Models](http://www.appliancefactoryparts.com)

----- Manual continues below -----

Quasar®

Room Air Conditioner

INSTALLATION AND OPERATING INSTRUCTIONS

Model: **HQ-2052UH**

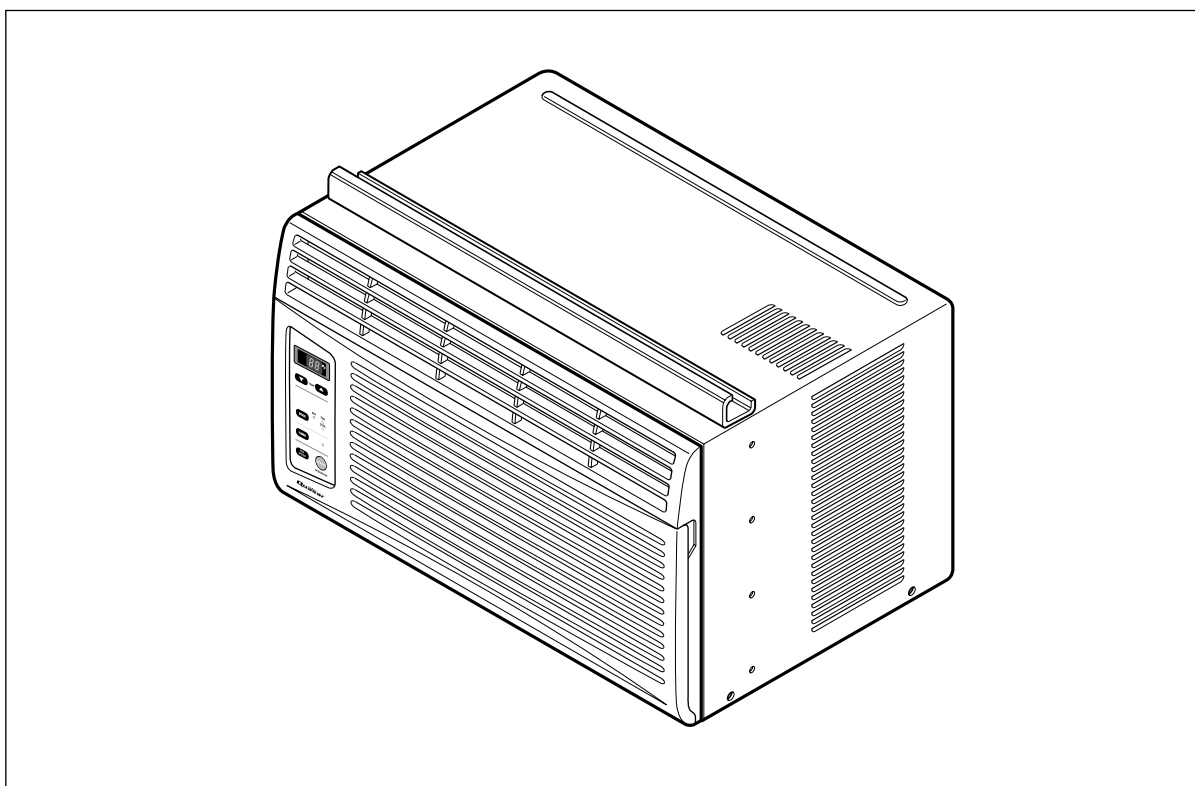

Please read these operating instructions thoroughly before using your air conditioner and keep for future reference.

For assistance, please call: 1-800-211-PANA(7262) or
Register your product at : <http://www.panasonic.com/register>

Safety Precautions

Safety Precautions3

About the Controls on the Air Conditioner

Controls5
 Air direction7
 Care and Maintenance7

Features and Installation

Features8
 Window Requirements9
 Electrical Data11

Before You Call For Service...

Normal Operation12
 Abnormal Operation12



FOR YOUR RECORDS

Write the model and serial numbers here:

Model # _____

Serial # _____

You can find them on a label on the side of the unit.

Dealer's Name _____

Date Purchased _____

Staple your receipt here for proof of purchase.

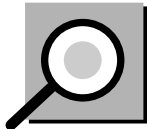

READ THIS MANUAL

Inside you will find many helpful hints on how to use and maintain your air conditioner properly. Just a little preventive care on your part can save you a great deal of time and money over the life of your air conditioner.

You'll find many answers to common problems in the chart of troubleshooting tips. If you review our chart of **Troubleshooting Tips** first, you may not need to call for service at all.



CAUTION

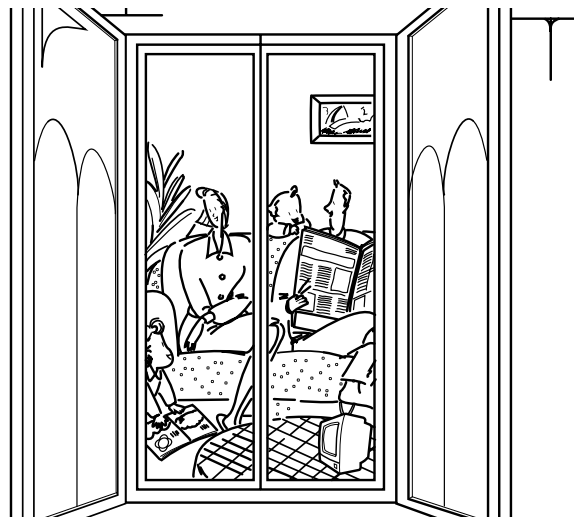

- Contact an Authorized Service Center for repair or maintenance of this unit.
- The air conditioner is not intended for use by young children or invalids without supervision.
- Young children should be supervised to ensure that they do not play with the air conditioner.





Safety Precautions

To prevent injury to the user or other people and property damage, the following instructions must be followed:



- Incorrect operation will cause harm or damage. The seriousness is classified by the following indications.
- Because of the weight of the product, it is recommended that you have a helper to assist in the installation.
- **Use Caution! Sharp Edges! See Warning, page 4.**

	WARNING : This symbol indicates the possibility of death or serious injury.
	CAUTION : This symbol indicates the possibility of injury or damage to property

■ Meanings of symbols used in this manual are as shown below.

	Be sure not to do this.
	Be sure to follow the instructions.

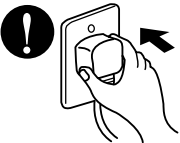
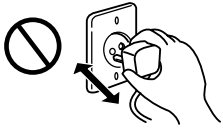
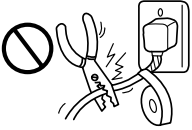
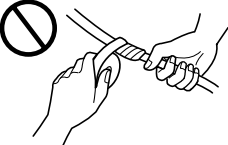
 **WARNING**

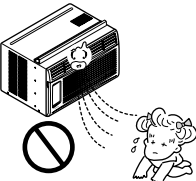
<p>Plug in the power plug properly.</p> <ul style="list-style-type: none"> • Otherwise, it will cause electric shock or fire due to heat generation. 	<p>Do not operate or stop the unit by inserting or pulling out the power plug.</p> <ul style="list-style-type: none"> • It will cause electric shock or fire due to heat generation. 	<p>Do not damage or use an unspecified power cord.</p> <ul style="list-style-type: none"> • It will cause electric shock or fire. • If the power cord is damaged, it must be replaced by the manufacturer or its service agent or a similarly qualified person in order to avoid a hazard. 
<p>Do not modify the length of the power cord or use an extension cord.</p> <ul style="list-style-type: none"> • It will cause electric shock or fire due to heat generation. 	<p>Do not operate with wet hands or in damp environment.</p> <ul style="list-style-type: none"> • It will cause electric shock. 	<p>Do not direct air flow at room occupants.</p> <ul style="list-style-type: none"> • This could lead to health problems. 

CAUTION

When the air filter is to be removed, do not touch the metal parts of the unit.

- They are sharp and may cause an injury.

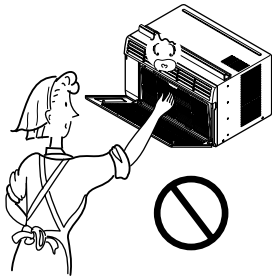

Do not clean the air conditioner with water.

- Water may enter the unit and degrade the insulation. It may cause an electric shock.

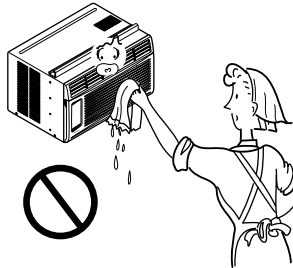

When the unit is to be cleaned, switch the unit off, and unplug it.

- Since the fan rotates at high speed during operation, it may cause an injury.

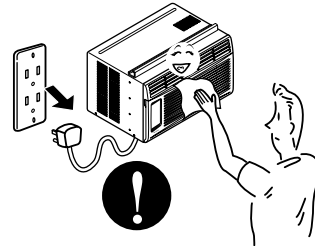

Do not operate the unit without the air filter or when the front intake grille has been removed.

- It could cause dust to accumulate on the heat exchanger.

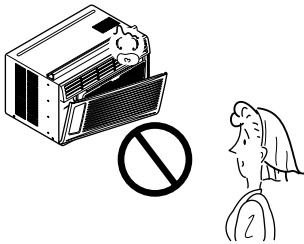

Do not put a pet or house plant where it will be exposed to direct air flow.

- This could injure the pets or plants.

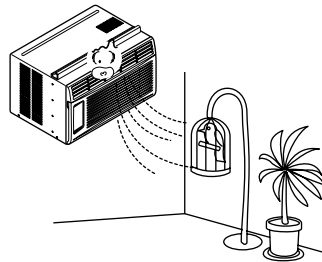

Do not use the unit for any other purpose than its intended use.

- Do not use this air conditioner to preserve precision devices, food, pets, plants, or art objects. It may cause deterioration of quality, etc.

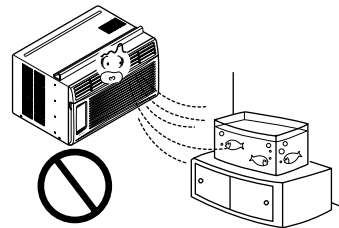

Do not operate switches with wet hands.

- It may cause an electric shock.

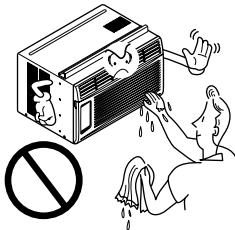

Do not apply an insecticide or flammable spray.

- It may cause a fire or damage of the cabinet.

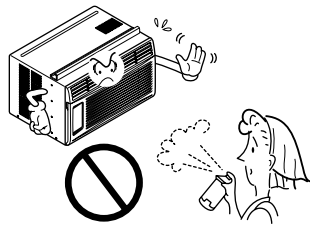

SHARP EDGES!

- Use caution when handling the case. Grip it firmly and do not allow it to slip while holding it.
- Use heavy gloves to handle the case if necessary.

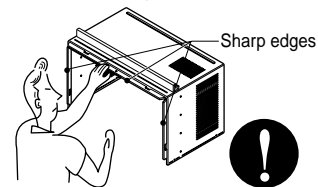

About the Controls on the air conditioner

The controls will look like the following.

Controls

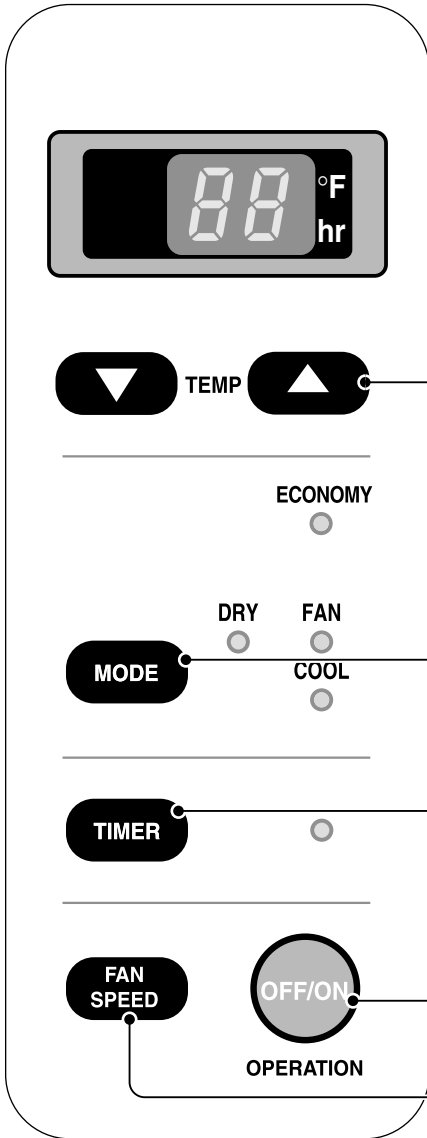

TEMPERATURE SETTING

- This button can automatically control the temperature of the room. The temperature can be set within a range of 60°F (16°C) to 86°F (30°C) by 1°F (1°C). Select the lower number for lower temperature of the room.

MODE

- Every time you push this button, it will toggle between COOL, ECONOMY, FAN and DRY.

ON/OFF TIMER

- STOPPING OPERATION
- Every time you push this button, when the unit is operating, timer is set as follows.
(1Hour → 2Hours → 3Hours → 4Hours → 5Hours → 6Hours → 7Hours → 8Hours → 9Hours → 10Hours → 11Hours → 12Hours → Cancel)
- The Setting Temperature will be raised by 2°F (1°C) 30 min. later and by 2°F (1°C) after another 30 min.

- STARTING OPERATION

- Every time you push this button, when the unit is not operating, timer is set as follows.
(1Hour → 2Hours → 3Hours → 4Hours → 5Hours → 6Hours → 7Hours → 8Hours → 9Hours → 10Hours → 11Hours → 12Hours → Cancel)

POWER

- To turn the unit ON, push the button. To turn the unit OFF, push the button again.
- This button takes priority over any other buttons.
- When you first turn it on, the unit is on the High cool mode and the temp. at 72°F (22°C).

FAN SPEED

- Every time you push this button it is set as follows.
{High(F2) → Low(F1) → High(F2)...}.

DRY

- When this unit is in dry mode, the fan rotates at low speed. The fan stops when the compressor stops cooling. Approximately every 3 minutes the fan will turn on and the unit checks the room air temperature to set itself.

Remote controller

Precaution: The Remote Controller will not function properly if strong light strikes the sensor window of the air conditioner or if there are obstacles between the Remote Controller and the air conditioner.

OPERATION BUTTON

- To turn the air conditioner ON, push the button. To turn the air conditioner OFF, push the button again.
- This button takes priority over any other buttons.
- When you first turn it on, the air conditioner is on the High cool mode and the temp. at 72°F (22°C).

ROOM TEMPERATURE SETTING BUTTON

This button can automatically control the temperature of the room. The temperature can be set within a range of 60°F to 86°F by 1°F. (16°C to 30°C by 1°C)
Select the lower number for lower temperature of the room.

ON/OFF TIMER BUTTON

- You can set the time when the unit will turn on or turn off automatically by pressing the timer button. If the unit is in operation, this button controls the time it will be turned off. If the unit is in off state, this button controls the time it will start. Every time you push this button, the remaining time will be set as follows:

- STOPPING OPERATION

- Every time you push this button, when the air conditioner is operating, timer is set as follows : (1Hour → 2Hours → 3Hours → 4Hours → 5Hours → 6Hours → 7Hours → 8Hours → 9Hours → 10Hours → 11Hours → 12Hours → 0Hour → 1Hour → 2Hours → ...)
- The Setting Temperature will be raised by 2°F (1°C) 30 min. later and by 2°F (1°C) after another 30 min.

- STARTING OPERATION

- Every time you push this button, when the air conditioner is not operating, timer is set as follows : (1Hour → 2Hours → 3Hours → 4Hours → 5Hours → 6Hours → 7Hours → 8Hours → 9Hours → 10Hours → 11Hours → 12Hours → 0Hour → 1Hour → 2Hours → ...)

OPERATION MODE SELECTION BUTTON

Every time you push this button, it will toggle between COOL, ECONOMY, FAN and DRY.

ECONOMY

- If you push this button, the fan stops when the compressor stops cooling. Approximately every 3 minutes the fan will turn on and check the room air to determine if cooling is needed.

FAN SPEED SELECTION BUTTONS

Every time you push this button, it is set as follows.
{High(F2) → Low(F1) → High(F2)...}.

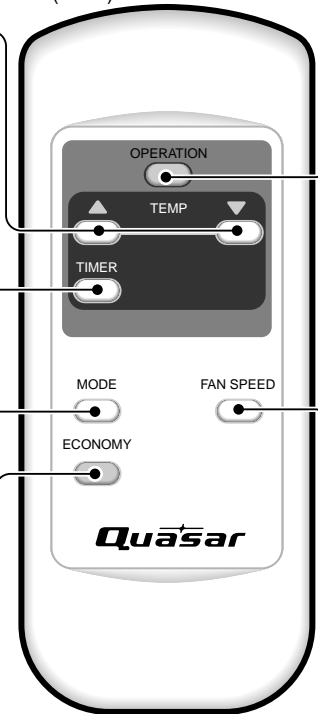

How to Insert Batteries

1. Remove the cover from the back of the remote controller
2. Insert two batteries.
 - Be sure that the (+) and (-) directions are correct.
 - Be sure that both batteries are new.
3. Re-attach the cover.



- Do not use rechargeable batteries. Such batteries differ from standard dry cells in shape, dimensions, and performance.
- Remove the batteries from the remote controller if the air conditioner is not going to be used for an extended length of time.

Additional controls and important information.

Air Direction

- **ADJUSTING THE AIR DIRECTION USING THE HORIZONTAL AIR-DEFLECTOR CONTROL**

Using the control tabs, the air flow can be directed to the left, right, straight ahead, or any combination of these directions.

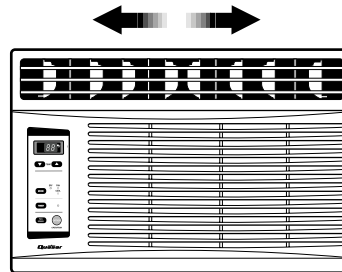

Care and Maintenance

TURN THE AIR CONDITIONER OFF AND REMOVE THE PLUG FROM THE POWER OUTLET.

- **TO CLEAN FILTER**

The air filter will become dirty as it removes dust from the inside air. It should be washed at least every 2 weeks. If the air filter remains full of dust, the air flow will decrease and the cooling capacity will be reduced, possibly damaging the unit.

1. Pull the inlet grille forward and pull out the air filter. (Fig. 1)
2. Wash the air filter in warm 104°F (40°C) water. Be sure to shake off all the water before replacing the filter.

Do not force open or open too far (about 56°)

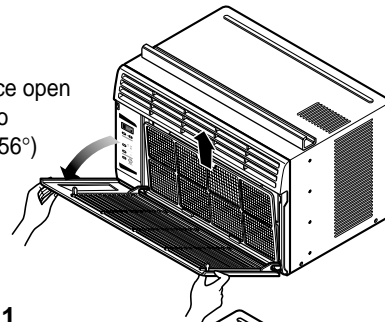
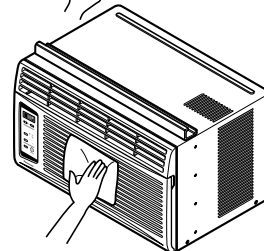

Fig. 1

- **CLEANING THE AIR CONDITIONER**

The front grille and inlet grille may be wiped with a cloth dampened in a mild detergent solution. (Fig. 2) The cabinet may be washed with mild soap or detergent and lukewarm water, then polished with a liquid wax used for appliances.

Fig. 2



To ensure continued peak efficiency, the condenser coils (outside of unit) should be checked periodically and cleaned if clogged with soot or dirt from the atmosphere.

- **HOW TO REMOVE THE FRONT GRILLE**

1. Pull the inlet grille forward.
2. Remove the screw securing the front grille. (Fig. 3)
3. Push the grille up from the bottom and pull the top of the grille away from the case as the top tabs lift out of their slots. (Fig. 4)

Fig. 3

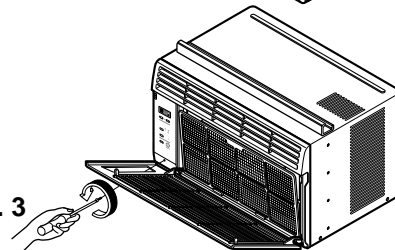
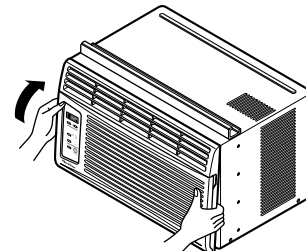

Fig. 4



Features and Installation

Learning parts name prior to installation will help you understand the installation procedure.

Features

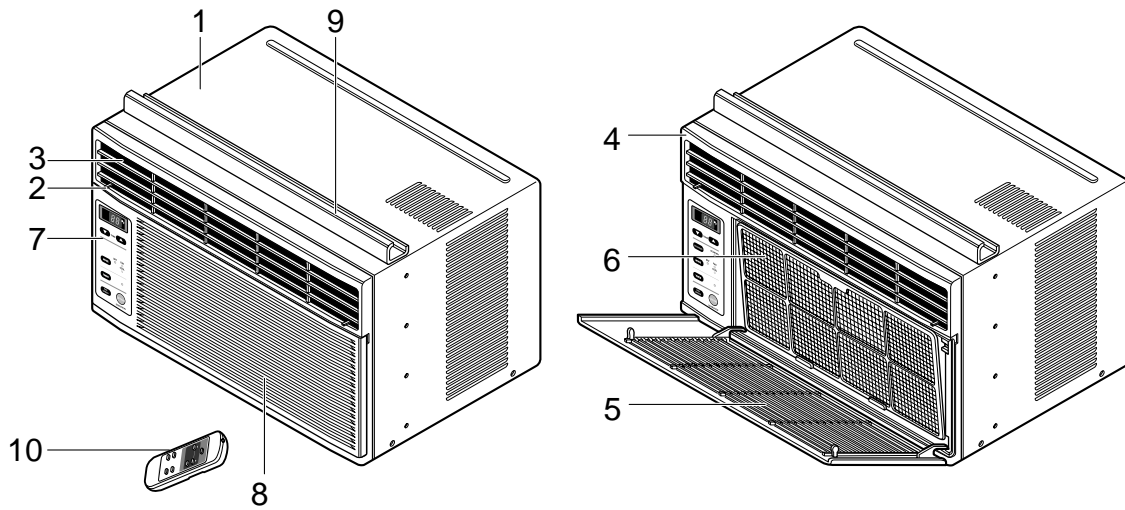

- | | |
|-----------------------------|-----------------------|
| 1. CABINET | 6. AIR FILTER |
| 2. HORIZONTAL AIR DEFLECTOR | 7. CONTROL BOARD |
| 3. COOL AIR DISCHARGE | 8. AIR INTAKE |
| 4. FRONT GRILLE | 9. UPPER GUIDE |
| 5. INLET GRILLE | 10. REMOTE CONTROLLER |

■ How to install wire net on the back side of the cabinet (Optional : CW353020031B)

Insert the rear grill wire ends into the 4 respective slots provided along the groove at the back of unit

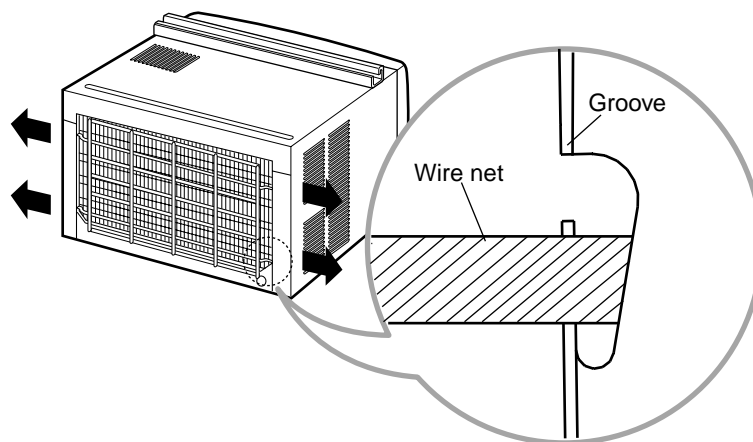

Window Requirements

NOTE: All supporting parts should be secured to firm wood, masonry, or metal.

1. This unit is designed for installation in standard double hung windows with actual opening widths of 22" to 36". The upper and lower sash must open sufficiently to allow a clear vertical opening of 13" from the bottom of the sash to the window stool.
2. If a storm window presents interference, fasten a 2" wide wood strip to the inner window sill across the full width of the sill. The wood strip should be thick enough to raise the height of the window sill so that the unit can be installed without interference by the storm window frame. See Fig. 5-2. The top of the wood strip should be approximately $\frac{3}{4}$ " higher than the storm window frame (STORM WINDOW FRAME) or wood strip (OUTDOORS) to help condensation to drain properly to the outside.
3. Install a second wood strip (approximately 18" long by $1\frac{1}{2}$ " wide and same thickness as first strip) in the center of the outer sill flush against the back off the inner sill. This will raise the L bracket as shown in Fig. 5-2.
4. The thickness of the second wood strip may not be the same as the first wood strip. The thickness of the second wood strip must be defined to keep the $\frac{3}{4}$ inch distance between the inner sill or the top of the first wood strip and the outer sill.

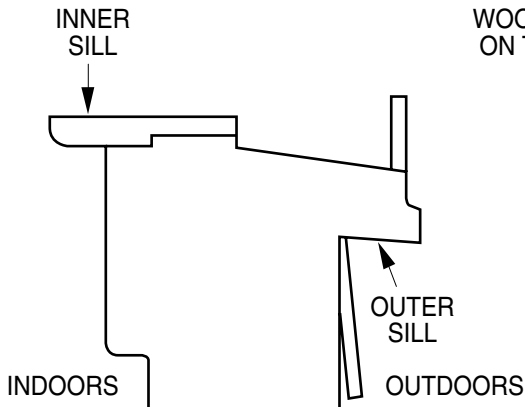

Fig. 5-1

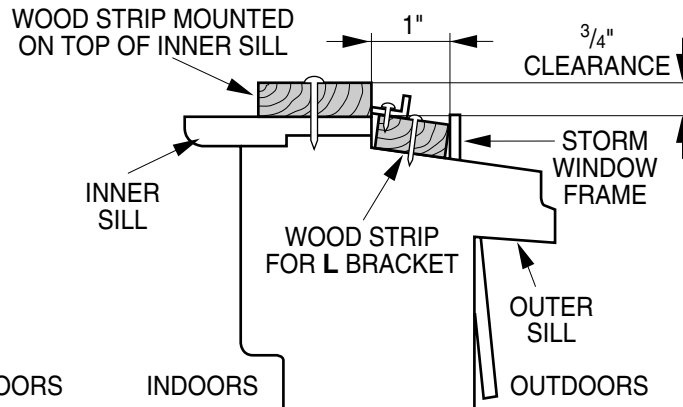

Fig. 5-2

Installation

HARDWARE			
TYPE A: Qty:11 (SHORT SCREW)	TYPE B: Qty:5 (WOOD SCREW)	TYPE C: Qty:3 (L BRACKET)	DRAIN PIPE Qty:1
TYPE D: Qty:1 (SEAL STRIP)	TYPE E: Qty:1 (SASH SEAL)	TYPE F: Qty:2 (GUIDE PANEL)	TYPE G: Qty:1 (SUPPORT BRACKET)
(Adhesive backed)	(Not adhesive backed)		

A. BEFORE INSTALLATION

1. Insert the guide panels into the guides of the air conditioner. Fasten the curtains to the unit with screws (TYPE A), as shown Fig. 6.
2. Cut the adhesive-backed seal strip (TYPE D) to the window width.
Remove the backing from the seal strip and attach the seal strip to the underside of the bottom window. (Fig. 7)

B. NOW START INSTALLATION

1. LOCATING UNIT IN A WINDOW

Open the window and mark center line on the center of the inner sill, as shown in Fig. 8.

2. ATTACH L BRACKET

- a. Install the L brackets behind the inner window sill, with short side of bracket as shown. Use the 2 screws (TYPE A) provided.
- b. The bracket helps to hold the unit securely in place. Be sure to place bracket edge flush against back of inner sill. See Fig. 9.

CAUTION

During the following step, hold unit firmly until window sash is lowered to top channel behind side panel frames. Personal injury or property damage may result if unit falls from window.

3. INSTALL THE AIR CONDITIONER IN THE WINDOW

- a. Carefully lift the air conditioner and slide it into the open window. Make sure the bottom guide of the air conditioner drops into the notches of the L bracket. See Fig. 9.

IMPORTANT :

When the air conditioner drops into the L bracket, the air conditioner will be centered in window opening as shown in Fig. 10.

- b. While steadying the air conditioner, carefully bring the window sash down behind the upper guide of the air conditioner, as shown in Fig. 11.

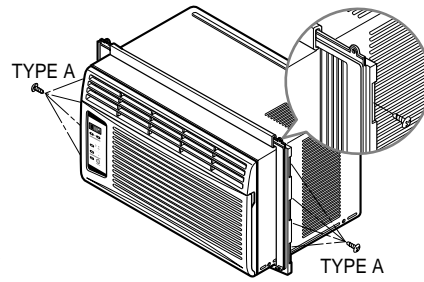

Fig. 6

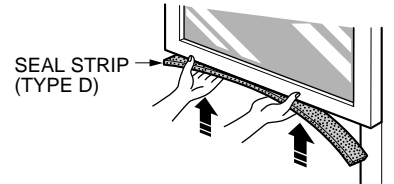

Fig. 7

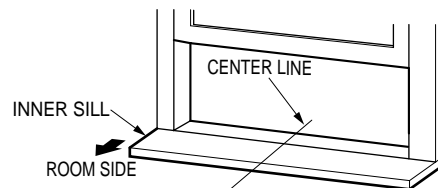

Fig. 8

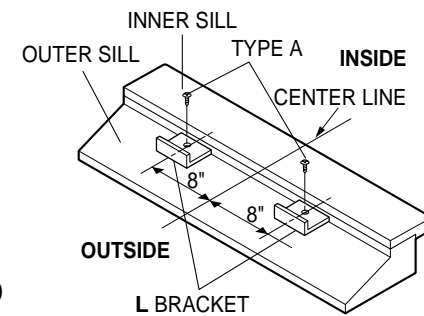

Fig. 9

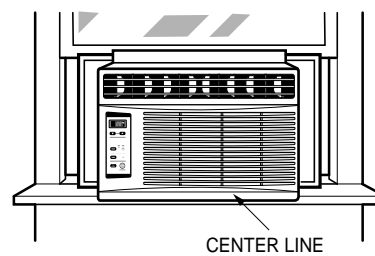

Fig. 10

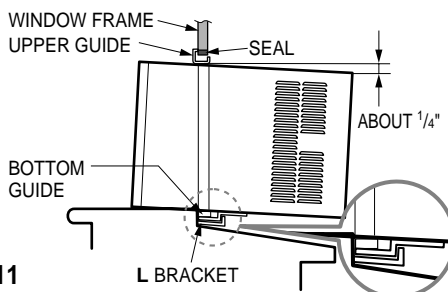

Fig. 11

4. SECURE THE GUIDE PANELS

Extend the guide panels (TYPE F) to fill the window opening using 4 screws (TYPE B) to secure them, as shown in Fig. 12.

5. INSTALL THE SASH SEAL AND SASH LOCK

- Cut the sash seal (TYPE E) to the window width. Stuff the sash seal between the glass and the window to prevent air and insects from getting into the room, as shown in Fig. 12.
- Fasten the L bracket using a screw (TYPE A), as shown in Fig. 12.

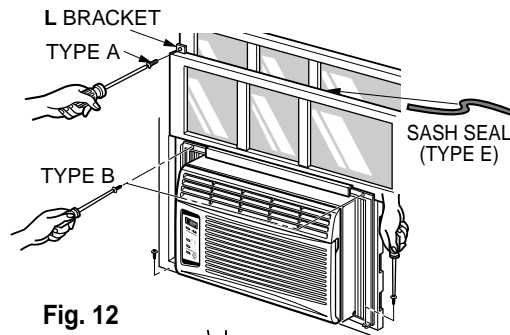

Fig. 12

- Remove the screws that secure the cabinet and base pan in the right side.
- Fasten the support bracket (TYPE G) using a removed screw. Attach the support bracket (TYPE G) in the inner window sill with a screw (TYPE B), as shown Fig. 13.

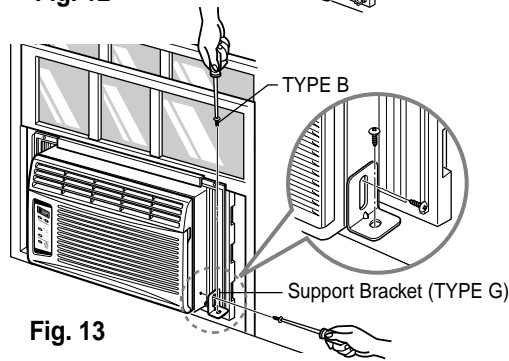

Fig. 13

7. Window installation of room air conditioner is now completed. See ELECTRICAL DATA for attaching power cord to electrical outlet.

C. HOW TO SECURE THE DRAIN PIPE

In humid weather, excess water may cause the BASE PAN to overflow. To drain the water, remove the DRAIN CAP and secure the DRAIN PIPE to the rear hole of the BASE PAN. (Fig. 14) Press the drain pipe into the hole by pushing down and away from the fins to avoid injury.

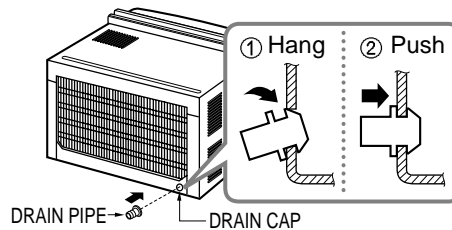
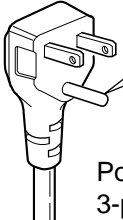
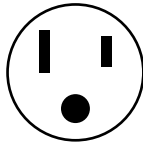

Fig. 14

REMOVAL FROM WINDOW

Turn the air conditioner off, disconnect the power cord, remove the Support Bracket, L bracket and the screws installed through the top and bottom of the guide panels, and save for reinstallation later. Close the guide panels. Keeping a firm grip on the air conditioner, raise the sash, and carefully tilt the air conditioner backward, draining any condensate. Lift the air conditioner from the window and remove the sash seal from between the windows.

Electrical Data

Line Cord Plug	Use Wall Receptacle	Power Supply
 <p>Do not under any circumstances cut or remove the grounding prong from the plug.</p> <p>Power supply cord with 3-prong grounding plug</p>	 <p>Standard 125V, 3-wire grounding receptacle rated 15A, 125V AC</p>	<p>Use 15 AMP, time delay fuse or circuit breaker.</p>

USE OF EXTENSION CORDS

Because of potential safety hazards, we strongly discourage the use of an extension cord. However, if you wish to use an extension cord, use a CSA certified/UL-listed 3-wire (grounding) extension cord, rated 15A, 125V.

Before you call for service...

Troubleshooting Tips save time and money!
Review the chart below first and you may not need to call for service.

Normal Operation

- You may hear a pinging noise caused by water being picked up and thrown against the condenser on rainy days or when the humidity is high. This design feature helps remove moisture and improve efficiency.
- You may hear the relay click when the compressor cycles on and off.
- Water will collect in the base pan during high humidity or on rainy days. The water may overflow and drip from the outdoor side of the unit.
- The fan may run even when the compressor does not.

Abnormal Operation

Problem	Possible Causes	What To Do
Air conditioner does not start	■ The air conditioner is unplugged.	• Make sure the air conditioner plug is pushed completely into the outlet.
	■ The fuse is blown/circuit breaker is tripped.	• Check the house fuse/circuit breaker box and replace the fuse or reset the breaker.
	■ Power failure.	• When power is restored, wait 3 minutes to restart the air conditioner to prevent tripping of the compressor overload.
Air conditioner does not cool as it should	■ Airflow is restricted.	• Make sure there are no curtains, blinds, or furniture blocking the front of the air conditioner.
	■ TEMP Control set to a higher number.	• Set the TEMP Control to a lower number.
	■ The air filter is dirty.	• Clean the filter at least every 2 weeks. See the operating instructions section.
	■ The room may have been hot.	• When the air conditioner is first turned on you need to allow time for the room to cool down.
	■ Cold air is escaping.	• Check for open furnace floor registers and cold air returns. • Set the air conditioner's vent to the closed position.
Air conditioner freezing up	■ Cooling coils have iced up.	• See Air Conditioner Freezing Up below.
	■ Ice blocks the air flow and stops the air conditioner from cooling the room.	• Set the mode control at High Fan or High Cool with the high temperature.

**Panasonic Consumer Electronics Company,
Division of Matsushita Electric Corporation
of America**
One Panasonic Way
Secaucus, New Jersey 07094

**Panasonic Sales Company,
Division of Matsushita Electric of Puerto Rico, Inc.,**
Ave. 65 de Infanteria, Km. 9.5
San Gabriel Industrial Park
Carolina, Puerto Rico 00985

Panasonic Room Air Conditioner Limited Warranty

Panasonic Consumer Electronics Company or Panasonic Sales Company (collectively referred to as "the Warrantor") will repair this product with new or refurbished parts in case of defects in material or workmanship, free of charge, in the USA or Puerto Rico in accordance to the following (All time periods start from the date of the original purchase).

SEALED REFRIGERATING SYSTEM (compressor and interconnecting tube): FIVE (5) YEARS - PARTS AND LABOR

ALL OTHER COMPONENTS: ONE (1) YEAR - PARTS AND LABOR

In-home service in the USA can be obtained during the warranty period by contacting a Panasonic Service Company (PASC) Factory Servicenter listed in the Servicenter Directory. Or call toll free, 1-800-211-PANA(7262), to locate a PASC authorized Servicenter. In-home service in Puerto Rico can be obtained during the warranty period by calling the Panasonic Sales Company telephone number listed in the Servicenter Directory.

Note: If the unit is installed at the other than normal window height and/or has been custom-installed (e.g., through the wall), the customer is responsible for removing the unit from its installation prior to the performance of in-home service.

This warranty is extended only to the original purchaser. A purchase receipt or other proof of date of the original purchase is required for service and parts replacement under this warranty.

This warranty only covers failures due to defects in materials and workmanship and does not cover normal wear or cosmetic damage. The warranty does not cover damages which occur in shipment, or failures which are caused by products not supplied by the warrantor, or failures which result from accident, misuse, abuse, neglect, mishandling, misapplication, faulty installation, maladjustment of customer controls, improper maintenance, alteration, modification, power line surge, lightning damage, improper voltage supply, commercial use such as hotel, office, restaurant, or other business or rental use of the product, or service by anyone other than a PASC Factory Servicenter or a PASC authorized Servicenter, or damage that is attributable to acts of God.

LIMITS AND EXCLUSIONS

There are no express warranties except as listed above.

THE WARRANTOR SHALL NOT BE LIABLE FOR INCIDENTAL OR CONSEQUENTIAL DAMAGES RESULTING FROM THE USE OF THIS PRODUCT, OR ARISING OUT OF ANY BREACH OF THIS WARRANTY ALL EXPRESS AND IMPLIED WARRANTIES, INCLUDING THE WARRANTIES OF MERCHANTABILITY, ARE LIMITED TO THE APPLICABLE WARRANTY PERIOD SET FORTH ABOVE.

Some states do not allow the exclusion or limitation of incidental or consequential damages or limitations on how long an implied warranty lasts, so the above exclusions or limitations may not apply to you.

This warranty gives you specific legal rights and you may also have other rights which vary from state to state. If a problem with this product develops during or after the warranty period, you may contact your dealer or Servicenter. If the problem is not handled to your satisfaction, then write to the Consumer Affairs Department at the company address indicated above.

SERVICE CALLS WHICH DO NOT INVOLVE DEFECTIVE MATERIALS OR WORKMANSHIP AS DETERMINED BY THE WARRANTOR, IN ITS SOLE DISCRETION, ARE NOT COVERED. COSTS OF SUCH SERVICE CALLS ARE THE RESPONSIBILITY OF THE PURCHASER.

[For assistance, please call: 1-800-211-PANA (7262) or send e-mail to consumerproducts@panasonic.com]

Printed in Korea