

This Owner's Manual is provided and hosted by [Appliance Factory Parts](#).



FEDDERS AEP09D2C Owner's Manual

[Shop genuine replacement parts for FEDDERS
AEP09D2C](#)



[Find Your FEDDERS Air Conditioner Parts - Select From 1517 Models](#)

----- Manual continues below -----

Room Air Conditioner • Dehumidifier

Please read the operating instructions and safety precautions carefully and thoroughly before installing and operating your air conditioner.

Acondicionador de Aire • Deshumidificador

Por favor lea las instrucciones de funcionamiento y las precauciones de seguridad cuidadosa y totalmente antes de instalar y operar su acondicionador de aire.

Climatiseur autonome • Déshumidificateur

Veuillez lire attentivement et en entier ce guide d'utilisation et les mesures de sécurité ci-incluses avant de procéder à l'installation et à l'utilisation de votre climatiseur.

Write down the model and serial numbers

Use these numbers in any correspondence or service calls concerning your air conditioner. Keep your store receipt.

Escriba los números de modelo y de serie

Utilice estos números en cualquier correspondencia o llamada de servicio referente a su acondicionador de aire. Guarde el recibo de la tienda.

Inscrivez les numéros de modèle et de série

Utilisez ces numéros dans toute correspondance ou lors d'un appel pour une intervention concernant le climatiseur. Conservez le reçu du magasin.

Model No., No. de modelo, N° de modèle

Serial No., No. de serie, N° de série

Date of Purchase, Fecha de compra, Date d'achat

ENGLISH	Page
Important Safety Instructions	2
Installation	
Introduction	3
Window Installation	4
Control Panel	6
Operation	7
Maintenance	8
Service & Warranty	9
ESPAÑOL	
Instrucciones importantes de seguridad	10
Instalación	
Introducción.....	11
Instalación en la ventana	12
Panel de control	14
Funcionamiento	15
Mantenimiento	16
Servicio y garantía	17
FRANÇAIS	
Directives de sécurité importantes	18
Installation	
Introduction	19
Installation – fenêtre	20
Tableau de commande	22
Utilisation	23
Entretien	24
Service après-vente et garantie	25

Keep these instructions for future reference

Guarde estas instrucciones para referencia futura

Gardez ces instructions pour les consulter ultérieurement

For questions about installation, operation, or service please call – 1-217-347-6459 or email – customerservice@fedders.com

Si tiene preguntas sobre la instalación, funcionamiento o servicio, llame al – 1-217-347-6459 o escriba a – customerservice@fedders.com

Si vous avez des questions sur l'installation, l'utilisation ou le service après-vente, composez le – 1-217-347-6459 ou envoyez un courriel à – customerservice@fedders.com

Important safety instructions

Power Cord with Arc Detection Device

The power cord supplied with this air conditioner is equipped with an Arc Detection Device designed to shut off power to the unit when it senses an arc fault condition. An arc fault is an unintentional electrical discharge that occurs when electrical products or wires are damaged, aged, or improperly used. An arc fault can be potentially hazardous if left undetected.

⚠️ WARNING ⚠️

- Do not remove or modify this plug
- Do not use as an on/off switch
- Do not use outdoors
- Do not push furniture against or place furniture on the electrical cord. This can trip the test switch and/or damage the cord and become a potential condition for arcing
- Do not attempt to repair the cord. If the cord requires replacement, call an authorized servicer.
- The Arc Detection Device is not a Ground Fault Interrupter and should not be used as such
- The Arc Detection Device contains an electronic circuit board and should not be submerged or exposed to water spray

Resetting

If the Arc Detection Device has tripped, the reset button will pop up.

Follow these steps to reset the Arc Detection Device:

1. Unplug unit from electrical outlet
2. Press the reset button
3. Plug the unit back into electrical outlet
4. Check to see if power has returned to the unit

Testing

You should test the Arc Detection Device equipped power cord monthly, after every major electrical storm, or if power to your Room Air Conditioner has been interrupted.

Follow these steps to test the Arc Detection Device:

1. Unplug unit from electrical outlet
2. Press the reset button
3. Plug the unit back into electrical outlet
4. Press test button. Unit should trip and reset button will pop up.
5. Press reset button again for use

If above test fails, stop using the air conditioner and contact customer service by calling the following toll-free number: **1-800-332-6658**

or email: customerservice@fedders.com

⚠️ Warning ⚠️

Electrical Shock Hazard



- Plug unit only into grounded electrical outlet.
- Do not use an extension cord or plug adapter with this unit.
- Do not operate unit with filter removed.
- Failure to follow these precautions could result in electrical shock, fire or personal injury.
- Do not alter cord or plug end. Do not remove warning label on cord.

Important Grounding Requirements

Your unit will operate on any 115 volt, 3-pronged (grounded) 60 Hz circuit. A separate line is not required, but it is advisable not to overload the circuit with heavy duty appliances such as washing machines, etc.

For your safety, this unit is equipped with a 3-pronged, grounding plug and must be plugged into a properly grounded outlet. If your outlet is not of the proper type, it is your responsibility to have the outlet and wiring changed to the correct type. Do not cut off the third (grounding) prong. Do not use an adapter.

Power Supply:

115V, 60HZ
AC Only 1-Phase

Outlet Requirement:

3-Prong Grounding Type
125 V, 15 Amp



Minimum Wire Size:

#14 (A.W.G.) 3-Wire
Use Copper Wire Only

Circuit Protector:

15 Amp Time Delay Fuse
or Circuit Breaker

For Your Safety

- Do not store or use gasoline or other flammable vapors and liquids in the vicinity of this or any other appliance. The fumes can create a fire hazard or explosion.
- Do not introduce objects in the air discharge area. This could cause permanent damage to your unit.
- Do not pour liquids on the air conditioner as this could cause a malfunction. With the unit unplugged, use a damp cloth for cleaning your unit. This unit does not require water or ice to be added.
- Avoid using strong solvents to clean the air conditioner.
- Clean the air conditioner filter every two weeks to avoid overheating caused by air obstruction. Do not operate without filter.
- Do not obstruct the air intake area of your air conditioner, as this could cause overheating, thus activating the unit's security switch and shutting off the unit.
- Do not block air circulation to exhaust tube when in use.
- Do not block air flow inside with blinds, curtains, or furniture.

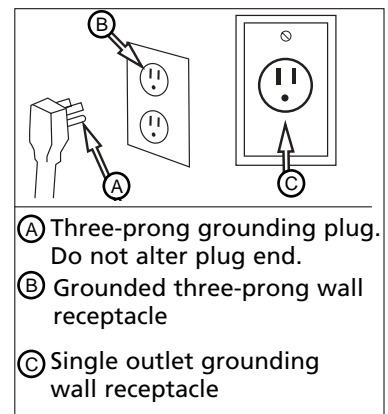

Description of Parts on the Portable Cooling Unit

- Control Panel** Use the electronic control panel to select the mode, fan speed, set the timer, or view the current and set room temperature.
- Air Outlet** The air outlet discharges the air from the unit into the room. Use the adjustable louvers to direct the air.
- Handles** Use the handles to help move the unit around the room
- Casters** Allow you to move the unit from one room to another without lifting
- Room Air Intake** Brings room air into the unit for cooling or dehumidifying
- System Air Intake** Outside air is brought into the unit to cool the internal components.
- Exhaust Port** Exhausts warm air from the internal components to the outside.
- Serial Plate** Identifies unit model and serial number
- Drain Valve** Drains the internal condensation tank
- Power Cord** Uses a 3-pronged, grounding plug and must be plugged into a properly grounded outlet. **Do not alter cord or plug end. Do not use an extension cord.**

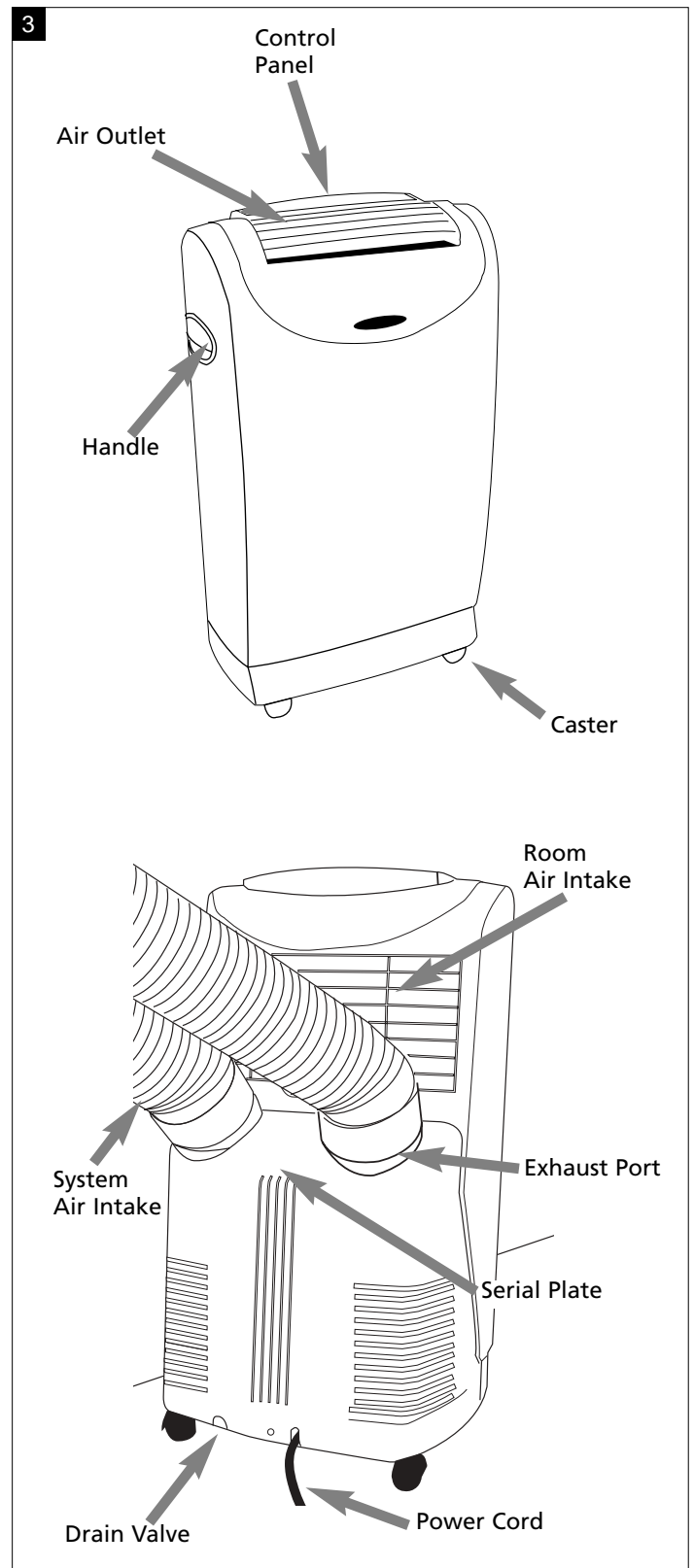

Before you start

- ⚠ Read the instruction manual before operating the unit for the first time. It contains important information on operation, safety, maintenance, service and warranty.
- ⚠ Do not start a damaged unit.
- ⚠ The assembly and connection of the unit must be carried out according to the instructions. If they are not followed you run the risk of voiding the warranty.
- ⚠ The power cord is located in the rear of the unit. Do not use plug adapters or extension cords. Do not alter plug end. Only use a grounded electrical outlet.
- ⚠ Do not allow contact between the unit and water.
- ⚠ Do not cover the air outlet or air intake louvers of the unit.
- ⚠ To avoid the possibility of personal injury, always disconnect the power supply to the unit before installing and /or servicing.

Window adapter kit

Window adapter kit

An installation parts kit is packed with your unit in a separate carton. Before you discard the packaging that your unit came in, please locate the carton that contains these parts and ensure that all parts are present.

Window panel Attaches to window opening to allow air exchange for system air transfer.

Window panel extensions Extends window panel to fit windows of various dimensions.

Tube adapters Connect Air exchange tubes to window panel.

Screws 12 screws are included for assembling the window adapter kit. Some screws may be partially assembled onto window panel.

Air exchange tubes Exchanges air between the unit and outdoors.

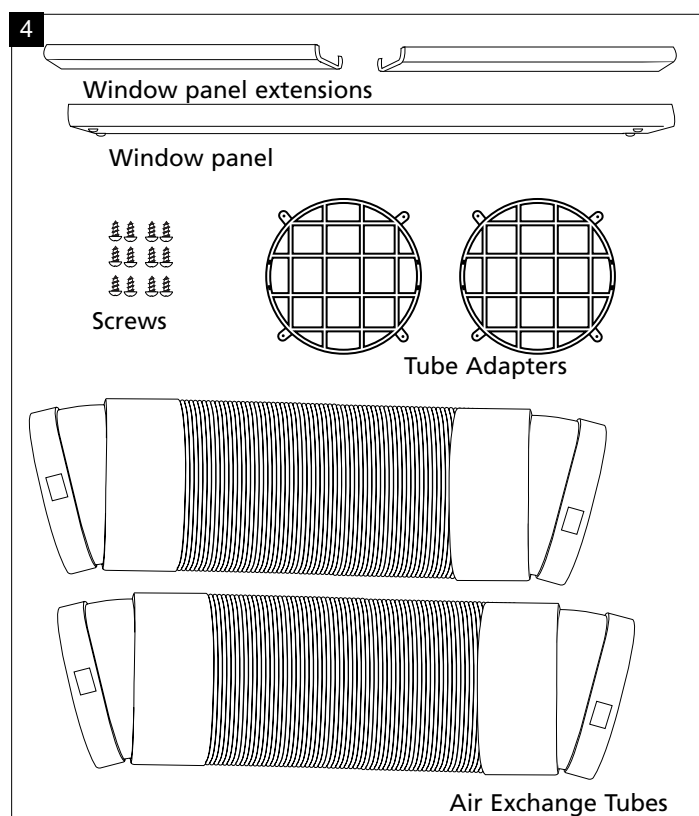

Instructions for assembling the window adapter kit

1. Insert tube adapters through the back of the window panel.
2. Secure each tube adapter with four screws through the front of the window panel.
3. Insert window panel extensions into window panel. Lightly tighten the screws in the window panel to hold the extensions in place.

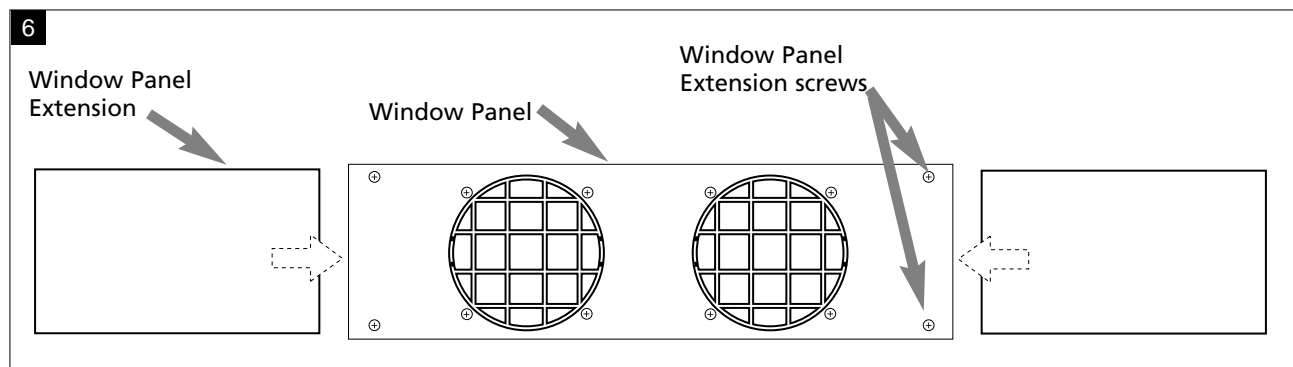
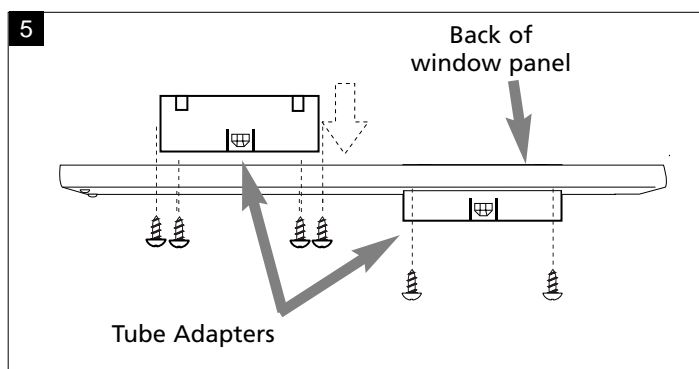

Window installation

Installing the window adapter kit

Note: The window adapter kit must be installed and connected for the air conditioner to work properly in Cool mode. The window adapter kit is not required when using the unit in Dehumidify, or Fan modes.

Your window adapter kit has been designed to fit most standard vertical and horizontal window applications. However, it may be necessary for you to improvise/modify some aspects of the installation procedures for certain types of windows.

1. Open window. (fig.A)
2. Place window panel with extensions into window frame and adjust to width of window. (fig.B)
Window adapter kit may be installed vertically as well as horizontally. This installation may also be used for crank style windows. (fig.E)
3. Tighten the four screws on the window panel to secure the window panel extensions. (fig.C)
4. Close window. (fig.C)
5. The window adapter kit should now fit securely within the window frame and you can now attach the air exchange tubes. If you are having trouble attaching the air exchange tubes, you may attach the tubes prior to installing the window adapter kit.

Attaching the air exchange tubes to the air conditioner

1. Attach the tubes to the window adapter kit.
2. Attach the other end to the air conditioner.

To attach air exchange tubes: push tube onto tube adapter and twist until the tab is in place in the hole on the tube.

To remove air exchange tubes: twist the end until the tab is clear of the hole in the tube and pull off.

Do not attach the tubes if using the unit in dehumidify.

Maintain a clear distance (from walls, furniture, etc.) of at least 10 inches around the unit to allow proper air circulation and prevent damage to the unit.

Important: Do not over-stretch the exhaust tube or make any unnecessary bends in it.

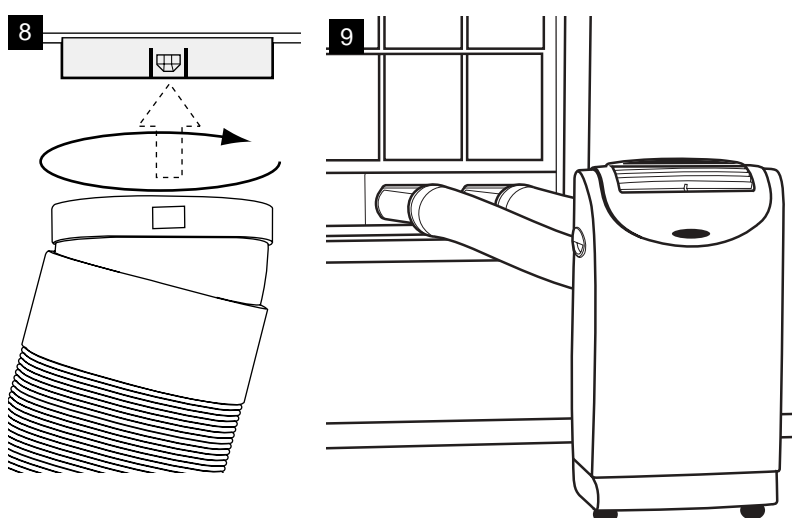
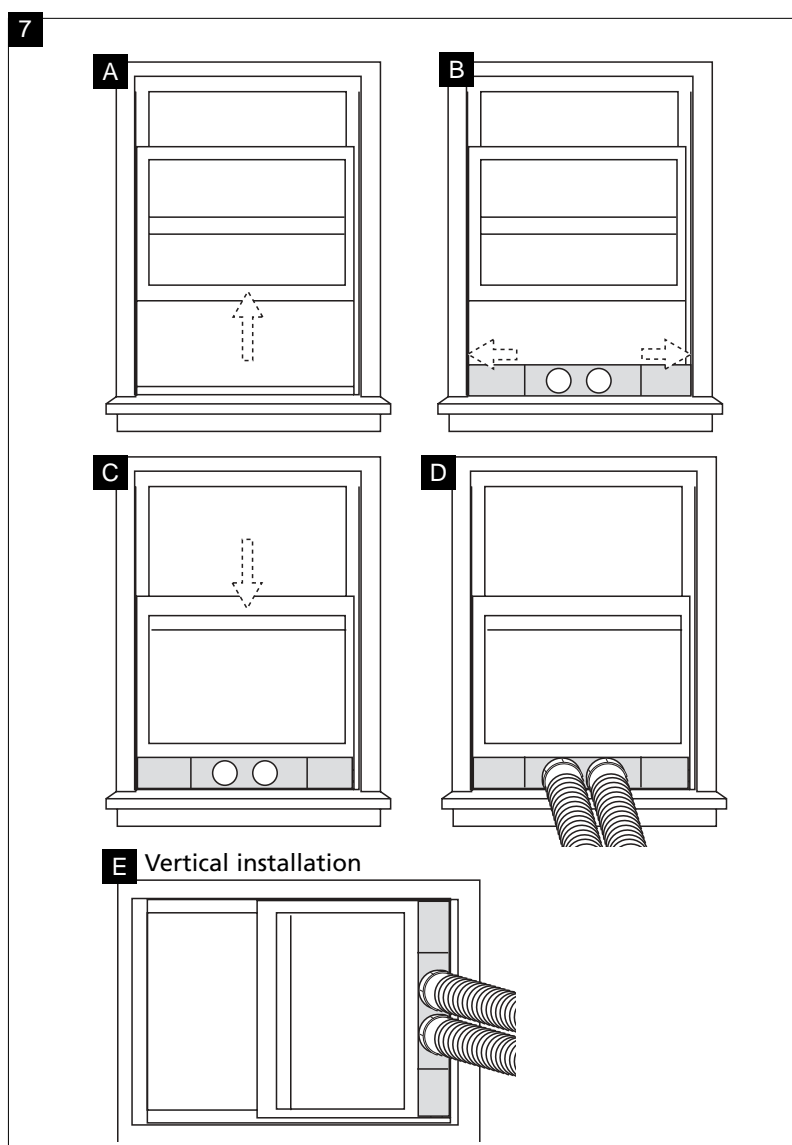

Control Panel

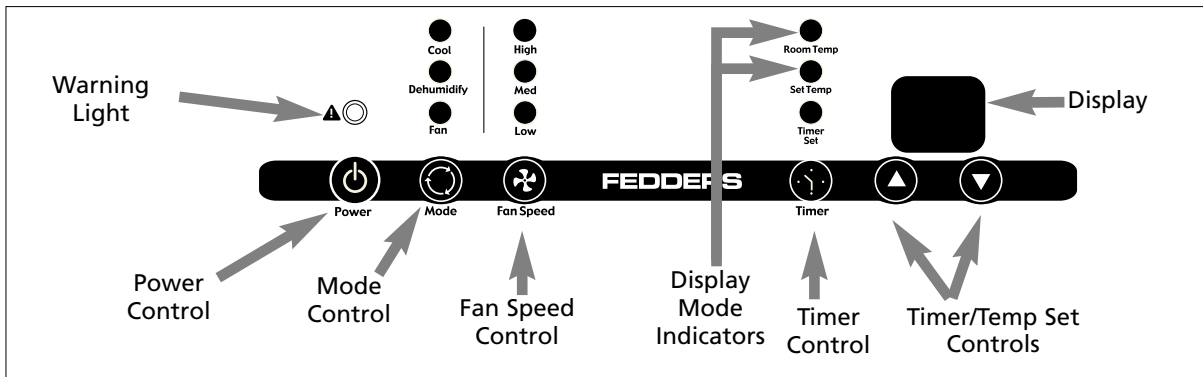

Power Control

The power control turns the unit on and off.

Warning Light

Condensed water may accumulate in the unit. If the internal tank becomes full, the Warning Light will shine and the unit **will not operate until the unit has been drained**. See Draining Excess Water section for instructions on how to drain the water.

Mode Control

The Mode Control has 3 settings: Cool, Dehumidify and Fan.

The settings are adjusted with the Mode Control button. A light will indicate which setting is currently being used.

Cool Mode

When Cool mode is selected, the indicator light will shine green. During the cooling mode the air is cooled and hot air is exhausted to the outside air through the exhaust tube. Adjust fan speed and temperature to suit your desired comfort level. **Note: The air exchange hoses must vent outside the room when using Cool Mode.**

Dehumidify Mode

When Dehumidify mode is selected, the indicator light will shine orange. Air is dehumidified as it passes through the unit, without being in full cooling mode. The fan will operate in Med speed. Fan speed is not adjustable in Dehumidify mode.

Note: The air exchange hoses must vent inside the room when using Dehumidify Mode.

Fan Mode

When Fan mode is selected the LED light will shine yellow. Air is circulated throughout the room with no cooling. (Note: unit does not need to be vented in Fan mode.)

Fan Speed Control

The Fan Speed Control has 3 settings: High, Medium, and Low.

Timer Control

Auto turn off:

With machine in fan mode, press timer button to select number of hours you would like the unit to run in air conditioning mode until it automatically shuts off.

Auto turn on:

With machine powered off, press timer button to select number of hours until you would like the unit to automatically start running in air conditioning mode.

Temp/Timer Set Controls

Used for adjusting the timer and thermostat.

The default display is room temperature.

When "+" or "-" button is pressed the set temperature is displayed and may be adjusted. After 15 seconds the display will revert back to room temperature.

Note: By pressing both Temp/Timer Set buttons at the same time, the display will toggle between Celsius and Fahrenheit.

Before starting this unit

1. Select a suitable location, making sure you have a level surface with no obstructions, and easy access to an electrical outlet.
2. Install the window adapter kit, as described in the Installation section.

Note: The window adapter kit is required only while using the Cool mode.

3. Plug the unit into a grounded electrical outlet. **Do not use an extension cord.**

Operating Instructions

Air Conditioner /Cool Mode

1. Install the window adapter kit and hoses to the unit.
2. Press the On/Off button to turn the unit on. The unit will power up and display the room temperature.
3. Press the Mode button until the green indicator light shines.
4. Press the Temp/Timer Set buttons to set the desired temperature. While you are adjusting the setting, the Set Temperature indicator will shine and the display will show the set temperature. After you have finished adjusting the temperature, the display will default back to the room temperature and the "Room Temp" indicator will shine.
5. Press the Fan Speed button to select the desired setting (High, Med, Low). The fan speed indicator light will shine for the selected speed.
6. Condensed water may accumulate in the unit. If the internal tank becomes full, the warning light will shine and the unit will not operate until the unit has been drained. See Draining Excess Water section for instructions on how to drain the water.
7. Once the room reaches the set temperature, the compressor will turn off and the fan will continue to operate.

Dehumidify Mode

1. Press the On/Off button to turn the unit on. The unit will power up and display the room temperature.
2. Press the Mode button until the orange indicator light shines above the word Dehumidify.
3. Condensed water may accumulate in the unit. If the internal tank becomes full, the warning light will shine and the unit will not operate until the unit has been drained. See Draining Excess Water section.
4. The fan will operate in Med speed. Fan speed is not adjustable in Dehumidify mode.

Fan Mode

1. Press the On/Off button to turn the unit on. The unit will power up and display the room temperature.
2. Press the Mode button until the yellow indicator light shines.
3. Press the Fan Speed button to select the desired setting (High, Med, Low). The fan speed indicator light will shine for the selected speed.
4. The unit will operate continuously in Fan mode.

Timer

The timer can be set to turn the unit off or on. The timer is adjustable between 1 and 12 hours.

To turn unit off automatically:

1. With unit running in desired mode, press timer button.
2. Use Temp/Timer Set buttons to select number of hours you would like the unit to run until it automatically shuts off. After you have finished adjusting the timer, the display will default back to the room temperature and the "Room Temp" indicator will shine. Timer indicator will blink when set. To turn timer off press the timer button.

To turn unit on automatically:

1. With unit powered on select desired mode and fan speed, then power unit off.
2. With machine powered off, press timer button to select number of hours until you would like the unit to automatically start running in air conditioning mode. Timer indicator will blink when set. The display will show the number of hours the unit is set until it begins operation. To turn timer off press the timer button.

Maintenance

Cleaning and Maintenance

- The unit has an air filter that must be cleaned with water every two weeks and put back in the unit after it is completely dry.
- The air discharge grille can be cleaned with a rag or sponge, warm water and mild detergent.
- Never use hot water, bleach, gasoline, acids, cleaning fluid or a brush to clean the unit. This will damage the cabinet and the air discharge area.
- Do not wash the unit with a hose.

Cleaning the filter.

1. Turn Power OFF.
2. Remove the air filter by grasping the bottom and pulling it up and out of the unit.
3. Wash in hot soapy water, rinse and shake dry.
4. Replace the filter with the front of the filter toward you.
5. To dry the filter thoroughly, run your unit in fan mode for a few minutes. Remember, only a clean filter works properly and delivers top efficiency at every setting.

Warning: Make sure unit is unplugged before performing any maintenance procedure.

Draining excess water

Condensed water may accumulate in the unit. If the internal tank becomes full, the Warning Light will shine and the unit will not operate until the unit has been drained.

First, unplug electrical cord from wall outlet. Then, drain excess water from the tank by placing a pan under the drain valve, removing the drain plug, and letting the water drain into the pan.

When the water stops draining out, replace the drain plug, and remove the pan of water. Operate the air conditioner in fan mode to dry the interior of the unit.

Always drain the unit before putting it into storage.

Air Conditioner Remote Control

The functions work the same as your air conditioner's touch controls.

Batteries: Remove the cover on the back of the remote controller and insert the batteries with the (+) and (-) poles pointing in the proper direction.

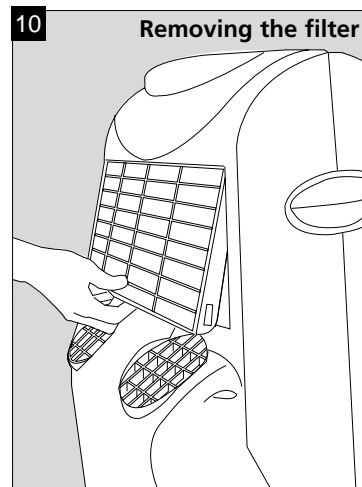
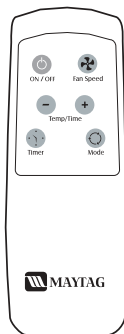

Proper use and care of your air conditioner will help ensure longer life of the unit. It is recommended to have a professional annually inspect and clean the coils and condensate water passages. Expense of annual inspection is the consumer's responsibility.

CAUTION

Failure to keep air filter clean will result in poor air circulation. DO NOT operate without filter. This can render the unit inoperative.

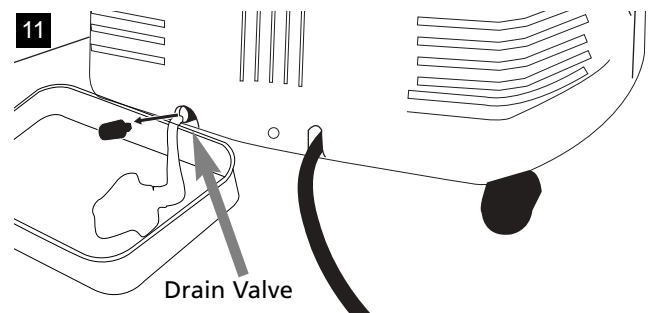

- CAUTION:**
- Use only AAA or IEC R03 1.5V batteries.
 - Do not attempt to recharge the supplied batteries
 - All batteries should be replaced at the same time.
 - Do not dispose of the batteries in a fire as they may explode.
 - Do not mix old and new batteries.
 - Do not install the batteries with the polarity (+/-) reversed.
 - Do not mix alkaline, standard (carbon - zinc), or rechargeable (nickel-cadmium) batteries.
 - Keep batteries and other things that could be swallowed away from young children. Contact a doctor immediately if an object is swallowed.

How to obtain Warranty Service or Parts

Service for your unit will be provided by CareCo, with authorized independent CareCo servicers nationwide.

*Note: Before calling for service, carefully read the Installation and Operating instructions booklet.
Then if you need service:*

1. Call a CareCo authorized servicer and advise them of model number, serial number, date of purchase and nature of complaint. Service will be provided during normal working hours. Contact your dealer for the name of an authorized servicer if unknown to you.
2. If your dealer is unable to give you the name of a servicer or if you need other assistance, call the following toll-free number for the name of an authorized servicer or authorized parts distributor:

1-800-332-6658

or you may write:

CareCo, Service Department

415 W. Wabash Ave., P.O. Box 200

Effingham, IL 62401

Proof of Purchase Date

It is the responsibility of the consumer to establish the original purchase date for warranty purposes. We recommend that a bill of sale, cancelled check, or some other appropriate payment record be kept for that purpose.

To locate your nearest Service Center, call 800-332-6658.

For models installed in North America – If service or parts are required

First, make the recommended checks. If it appears that service or parts are still required, see your warranty "How to Obtain Warranty Service or Parts". Please have the model number and serial number with you when calling.

For models installed outside of North America

For models purchased for use outside North America, the manufacturer does not extend any warranty either expressed or implied. Consult your local dealer for any warranty terms extended by the importer in your country.

Warranty

Within the 48 contiguous United States, State of Hawaii, the district of Columbia, Puerto Rico and Canada

Full (One) Year Parts and Labor Warranty

During the first year after the date of original purchase, Fedders Appliances will, through a network of authorized servicers and free of charge to the owner or any subsequent user, repair or replace any parts which are defective in material or workmanship due to normal use when the unit is delivered by the owner to and picked up from one of our authorized servicers. If requested, in-home service, pick-up, redelivery and reinstallation will be provided, but are the owner's responsibility.

Limited (Second through Fifth Year)

Sealed System Warranty

If any part of the sealed refrigerant system (consisting of compressor, evaporator, condenser, and interconnecting refrigerant tubing) should fail because of a defect in material or workmanship (including refrigerant charge), within the second through fifth year from the date of original purchase, Fedders Appliances, through a network of authorized servicers, will repair or replace such part, including labor, at no cost to the owner when the unit is delivered by the owner to and picked up from one of our authorized servicers. If requested, in-home service, pick-up, redelivery and reinstallation will be provided, but are the owner's responsibility.

Note: In the event of any required parts replacement within the period of this warranty, Fedders Appliances replacement parts shall be used and will be warranted only for the period remaining on the original warranty.

Exceptions

The above Limited Warranties do not cover failure to function caused by damage to the unit while in your possession (other than damage caused by defect or malfunction), or by its improper installation, or by unreasonable use of the unit, including without limitation, failure to provide reasonable and necessary maintenance or to follow the written Installation and Operating Instructions. If the unit is put to commercial, business, rental, or other use or application other than for consumer use, we make no warranties, express or implied, including, but not limited to, any implied warranty of merchantability or fitness for particular use or purpose.

THE REMEDIES PROVIDED FOR IN THE ABOVE EXPRESS WARRANTY ARE THE SOLE AND EXCLUSIVE REMEDIES THEREFOR, NO OTHER EXPRESS WARRANTIES ARE MADE ALL IMPLIED WARRANTIES, INCLUDING BUT NOT LIMITED TO ANY IMPLIED WARRANTY OF MERCHANTABILITY OR FITNESS FOR A PARTICULAR USE OR PURPOSE, ARE LIMITED IN DURATION TO ONE YEAR FROM THE DATE OF ORIGINAL PURCHASE. IN NO EVENT SHALL FEDDERS APPLIANCES BE LIABLE FOR INDIRECT, INCIDENTAL, OR CONSEQUENTIAL DAMAGES, EVEN IF ADVISED IN ADVANCE OF THE POSSIBILITY OF SUCH DAMAGES. NO WARRANTIES, EXPRESS OR IMPLIED, ARE MADE TO ANY BUYER UPON RESALE.

Some states do not allow limitations on how long an implied warranty lasts or do not allow the exclusion or limitation of incidental or consequential damages, so the above limitations or exclusions may not apply to you. This warranty gives you specific legal rights, and you may also have other rights which may vary from state to state.

No warranties are made for units sold outside of the above stated areas. Your distributor or final seller may provide a warranty on units sold outside of these areas.

Service Instructions

Read carefully before calling for service

If the unit fails to start

- Make sure the unit is plugged into an outlet.
- Make sure the unit is not in the off position.
- Make sure the circuit breaker has not been tripped.

If the unit does not cool sufficiently

- Make sure the exhaust tube and nozzle fit correctly to each other and to the window adapter.
- Make sure the exhaust tubes are not bent.
- Adjust the thermostat to a lower temperature.
- Make sure there are no objects inside the exhaust tube.

If the unit is too loud

- Make sure the exhaust tubes and nozzles fit correctly to each other and to the window mount.
- Make sure the exhaust tubes and nozzles are unobstructed.

Instrucciones de servicio

Lea atentamente antes de hacer una llamada de servicio

Si el acondicionador no funciona

- Asegúrese de que el acondicionador esté enchufado en el tomacorriente.
- Asegúrese de que el acondicionador no esté en la posición 'off' (apagado).
- Asegúrese de que el disyuntor no se haya disparado.

Si el acondicionador no enfría lo suficiente

- Asegúrese de que el tubo de evacuación y la boquilla estén correctamente unidos y que calcen correctamente en el adaptador de ventana.
- Asegúrese de que los tubos de evacuación no estén doblados.
- Coloque el termostato en una temperatura más baja.
- Asegúrese de que no haya objetos dentro del tubo de evacuación.

Si el acondicionador hace demasiado ruido

- Asegúrese de que los tubos de evacuación y las boquillas estén correctamente unidos y que calcen correctamente en el soporte de la ventana.
- Asegúrese de que los tubos de evacuación y las boquillas no estén obstruidos.

Instructions pour le service après-vente

Lisez attentivement ce manuel avant d'appeler le service après-vente.

Si l'appareil ne se met pas en marche

- Assurez-vous que l'appareil est bien branché.
- Assurez-vous que la commande de l'appareil est bien à la position Arrêt.
- Assurez-vous que le disjoncteur n'est pas déclenché.

Si l'appareil ne refroidit pas suffisamment

- Assurez-vous que le tube d'évacuation et l'adaptateur sont correctement installés, ainsi qu'à l'adaptateur de tube.
- Assurez-vous que les tubes d'évacuation ne sont pas déformés.
- Réglez le thermostat à une température plus basse.
- Assurez-vous qu'il n'y a pas d'objet dans le tube d'évacuation.

Si l'appareil est trop bruyant

- Assurez-vous que les tubes d'évacuation et les adaptateurs sont correctement installés, ainsi qu'au panneau de fenêtre.
- Assurez-vous que les tubes d'évacuation et l'embout ne sont pas bouchés.

Features and specifications subject to change without notice.

Las características y especificaciones están sujetas a cambio sin previo aviso.

Les caractéristiques et spécifications sont sujettes à modifications sans préavis.