

This Owner's Manual is provided and hosted by [Appliance Factory Parts](#).



# FRIEDRICH CP06E10 Owner's Manual

[Shop genuine replacement parts for FRIEDRICH  
CP06E10](#)



[Find Your FRIEDRICH Air Conditioner Parts - Select From 1575 Models](#)

----- Manual continues below -----

***Friedrich***<sup>®</sup>

# Room Air Conditioner Service and Parts Manual

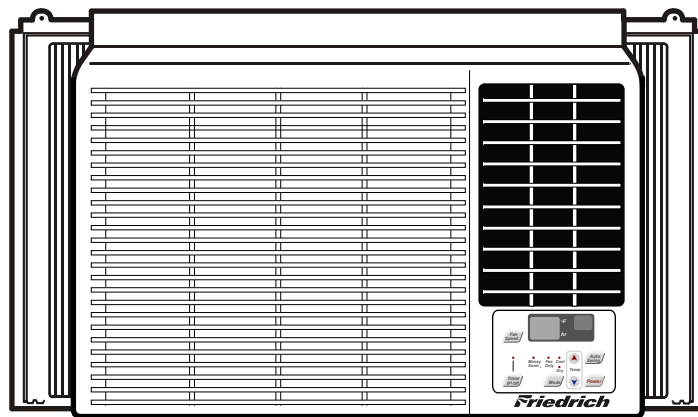

115Volts • CP08E10 • CP06E10

# TABLE OF CONTENTS

<b>Safety Precautions</b> .....	3
<b>Dimensions</b> .....	6
Outside Dimensions .....	6
<b>Product Specifications</b> .....	7
<b>Operation</b> .....	8
How to Operate Your Friedrich CP.....	9
<b>Disassembly</b> .....	10
Mechanical Parts.....	10
Air Handling Parts .....	11
Electrical Parts .....	12
Refrigerating Cycle.....	13
<b>Schematic Diagram</b> .....	16
Wiring Diagram.....	16
Electronic Control Device .....	17
Components Location(For Main P.W.B ASM).....	18
<b>Troubleshooting Guide</b> .....	19
Piping System .....	19
Troubleshooting Guide .....	20
<b>Exploded View</b> .....	28
<b>Replacement Parts List</b> .....	29

# Safety Precautions



To prevent injury to the user or other people and property damage, the following instructions must be followed.

- Incorrect operation due to ignoring instructions will cause harm or damage. The seriousness is classified by the following indications.

**⚠ WARNING** This symbol indicates the possibility of death or serious injury.

**⚠ CAUTION** This symbol indicates the possibility of injury or damage to property only.

- Meanings of symbols used in this manual are as shown below.

	<b>Be sure not to do.</b>
	<b>Be sure to follow the instruction.</b>

## ⚠ WARNING

**Always install the expansion panel(s).**

- Improper assembly or installation may cause incorrect operation, including injury, fire, and electric shock hazards.



**Do not place the power cord near a heater.**

- It may cause fire and electric shock.

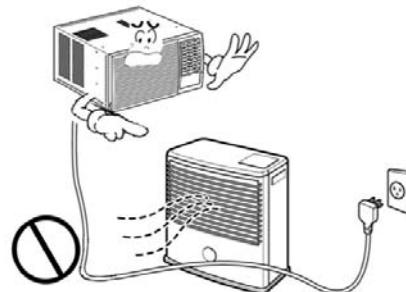

**Do not use the power cord near flammable gas or combustibles such as gasoline, benzene, thinner, etc.**

- It may cause explosion or fire.



**Do not disassemble or modify products.**

- It may cause failure and electric shock.



**Plug in the power plug properly.**

- Otherwise, it will cause electric shock or fire.

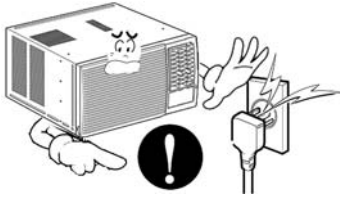

**Do not operate or stop the unit by inserting or pulling out the power plug.**

- It will cause electric shock or fire.



**Do not damage or use an unspecified power cord.**

- It will cause electric shock or fire.

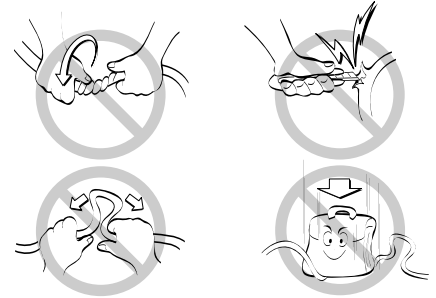

**Do not modify power cord length.**

- It will cause electric shock or fire.

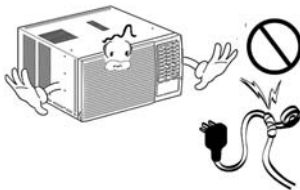

**Use the air conditioner on a single outlet circuit. (see page 7.) Do not share the outlet with other appliances.**

- It will cause electric shock or fire.

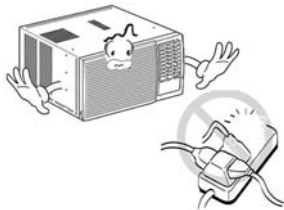

**Always plug into a grounded outlet.**

- No grounding may cause electric shock.

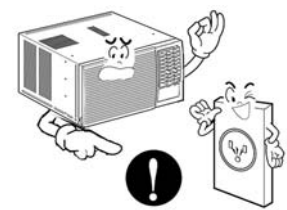

**Ventilate before operating air conditioner when gas goes out.**

- It may cause explosion, fire, and burn.



**Do not use the socket if it is loose or damaged.**

- It may cause fire and electric shock.

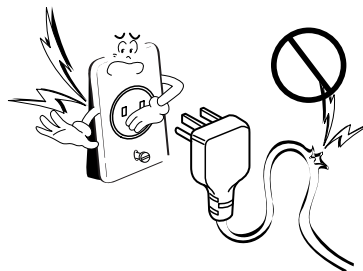

**Do not operate with wet hands or in damp environment.**

- It will cause electric shock.



If water enters the product, turn off the the power switch of the main body of appliance. Contact service center after taking the power-plug out from the socket.

- It will cause electric shock or failure of machine.



Do not clean the air conditioner with water.

- Water may enter the unit and degrade the insulation. It may cause an electric shock.



**! CAUTION**

Never touch the metal parts of the unit when removing the filter.

- They are sharp and may cause injury.



Do not block the inlet or outlet.

- It may cause failure of appliance or performance deteriorate.

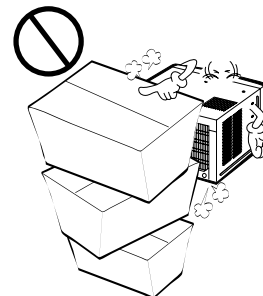

Ensure that the outer case is not damaged by age or wear.

- Leaving it damaged could result in the air conditioner falling out of the window, creating a safety hazard.

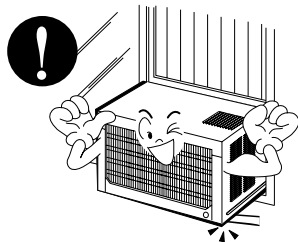

Be cautious not to touch the sharp edges when installing.

- It may cause injury.

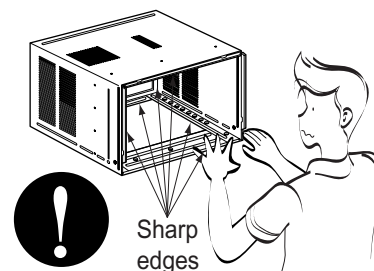

# Dimensions

## Symbols Used in this Manual



This symbol alerts you to the risk of electric shock.



This symbol alerts you to hazards that could cause harm to the air conditioner.

**NOTICE**

This symbol indicates special notes.

## Outside Dimensions

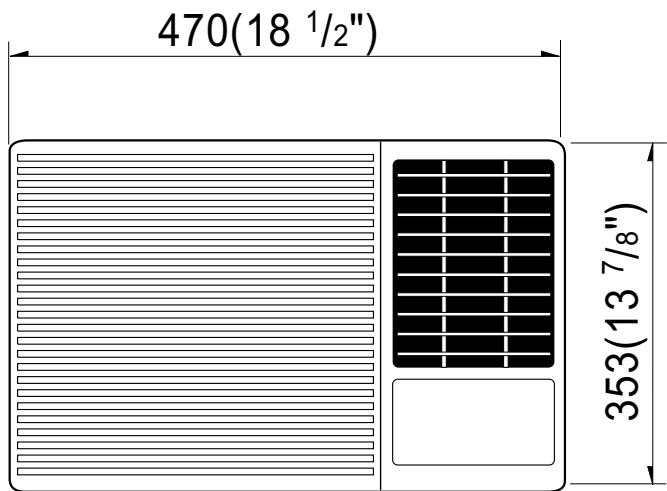
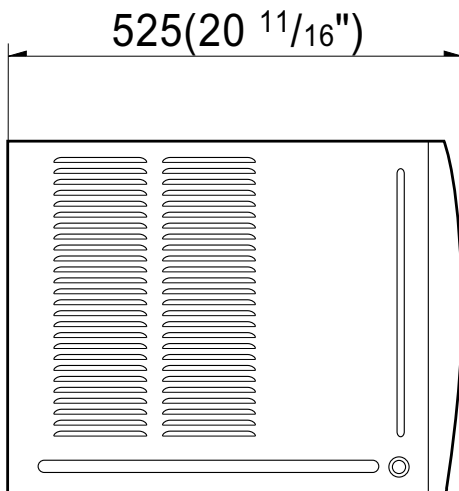

# Product Specifications

ITEMS		MODLES	
		CP08E10	CP06E10
POWER SUPPLY		1Ø, 115, 60Hz	
COOLING CAPACITY	(Btu/h)	7,800	6,000
INPUT	(W)	720	560
RUNNING CURRENT	(A)	6.8	5.1
E.E.R (BTU/W.h)		10.8	10.7
OPERATING	INDOOR (C)	26.7(DB)*	19.4(WB)**
	OUTDOOR (C)	35(DB)*	23.9(WB)**
REFRIGERANT (R-22) CHARGE		490g(17.3 oz)	285g(10.1 oz)
EVAPORATOR		Ø7.0, 2ROW 14STACKS	
CONDENSER		Ø5.0, 2ROW 16STACKS	
FAN, INDOOR		TURBO FAN	
FAN, OUTDOOR		PROPELLER TYPE FAN WITH SLINGER RING	
FAN SPEEDS, FAN/COOLING		3/3	
FAN MOTOR		6 POLES	
OPERATION CONTROL		REMOTE CONTROLLER	
ROOM TEMP. CONTROL		THERMISTOR	
AIR DIRECTION CONTROL		HORIZONTAL LOUVER (UP & DOWN), AUTOSWING LOUVER (RIGHT&LEFT)	
CONSTRUCTION		SLIDE IN-OUT CHASSIS	
PROTECTOR	COMPRESSOR	OVERLOAD PROTECTOR	
	FAN MOTOR	INTERNAL THERMAL PROTECTOR	
POWER CORD		3 WIRE WITH GROUNDING	
		ATTACHMENT PLUG (CORD-CONNECTED TYPE)	
DRAIN SYSTEM		DRAIN PIPE OR SPLASHED BY FAN SLINGER	
OUTSIDE DIMENSION (W x H x D)	(inch)	18 1/2 x 13 7/8 x 20 11/16	
	(mm)	469 x 353 x 526	

\* DB:Dry Bulb

\*\*WB:Wet Bulb



# Operation

- DESIGNED FOR COOLING ONLY
- POWERFUL AND INCREDIBLE COOLING
- TOP-DOWN CHASSIS FOR THE SIMPLE INSTALLATION AND SERVICE
- BUILT-IN ADJUSTABLE THERMOSTAT
- WASHABLE ONE-TOUCH FILTER
- COMPACT SIZE

## *Location and Function of Controls*

# How to operate your Friedrich CP

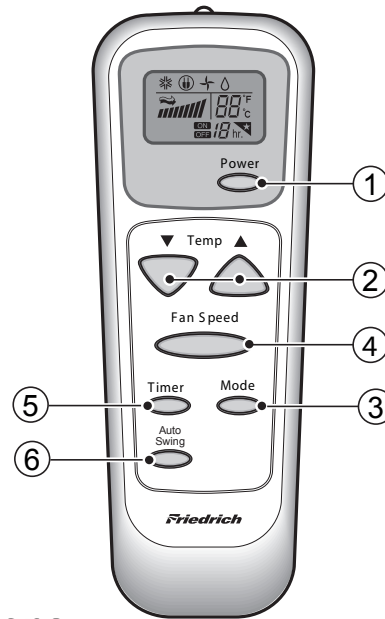
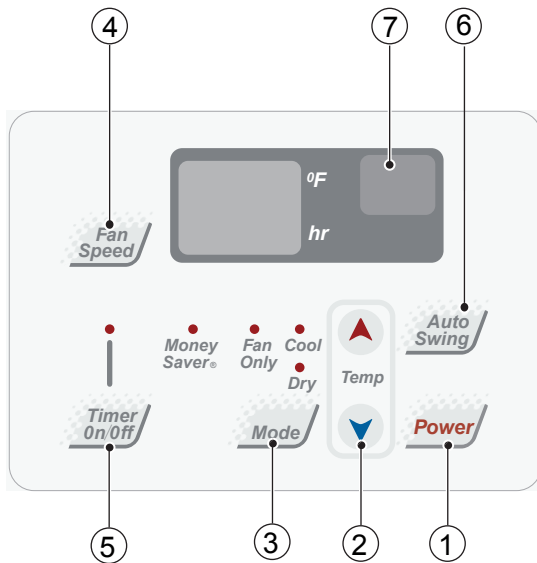

## Control and Remote Control Operations

### 1. POWER

Operation begins when this button is pressed and stops when you press the button again.

### 2. TEMPERATURE CONTROL

The thermostat monitors room temperature to maintain the desired temperature. The thermostat can be set between 60°F~86°F (16°C~30°C).

### 3. OPERATION MODE SELECTOR

Select cooling mode to cool the room.  
 Select Money Saver® mode for energy saving operation.  
 Select fan mode for basic ventilating fan operation.  
 Select dry mode for dry operation. (dehumidify operation)

### 4. FAN SPEED SELECTOR

For increased power while cooling, select a higher fan speed.  
 3 speeds: Low; Med; High

### 5. ON/OFF TIMER

ON: If the unit is off, use Timer to set number of hours before unit starts.

- Push Timer button to advance setting from 1hr - 2hrs - ...12hrs maximum.

OFF: You will usually use shut-off time while you sleep.

- If unit is running, use Timer to set number of hours until shut-off.
- For your sleeping comfort, once Time is set, the temperature setting will rise 2°F after 30min, and once again after 30min.
- Push Timer button to advance setting from 1hr 2hrs....12hrs maximum.

### 6. AUTO SWING

This button can automatically control the air flow direction(left+right).

### 7. REMOTE CONTROL SENSOR

To receive the signal from remote controller.

## Inserting the Remote Control Batteries

1. Push out the cover on the back of the remote control with your thumb
2. Pay attention to polarity and insert two new AAA 1.5V batteries.
3. Reattach the cover.



**NOTE:** Do not use rechargeable batteries. Make sure that both batteries are new.

- In order to prevent discharge, remove the batteries from the remote control if the air conditioner is not going to be used for an extended period of time

Keep the remote control away from extremely hot or humid places.

To maintain optimal operation of the remote control, the remote sensor should not be exposed to direct sunlight.

# Disassembly

— Before the following disassembly, POWER SWITCH set to OFF and disconnect the power cord.

## Mechanical Parts

### 1. FRONT GRILLE

1. Open the Inlet grille upward or downward.
2. Remove the screw which fastens the front grille.
3. Pull the front grille from the right side.
4. Remove the front grille.
5. Re-install the component by referring to the removal procedure, above.(See Figure 17)

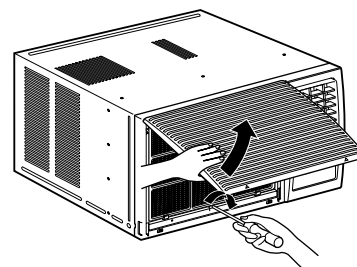

Figure 17

### 2. CABINET

1. After disassembling the FRONT GRILLE, remove the 2 screws which fasten the cabinet at both sides.
2. Remove the 2 screws which fasten the cabinet at back.
3. Pull the base pan forward. (See Figure 18)
4. Remove the cabinet.
5. Re-install the component by referring to the removal procedure, above.

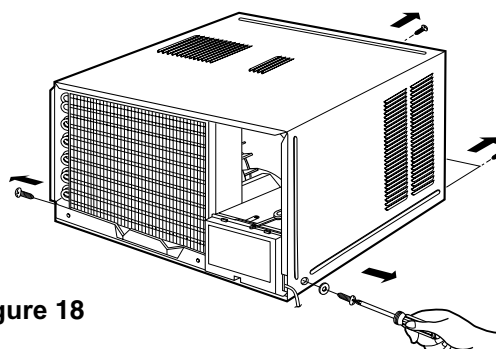

Figure 18

### 3. CONTROL BOX

1. Disconnect the unit from the power source.
2. Remove the front grille.
3. Remove the cabinet.
4. Remove the screw which fastens the control box cover.
5. Remove the housing which connects motor wire in the control box.
6. Remove the 3 leads from the compressor.
7. Discharge the capacitor by placing a 20,000 ohm resistor across the capacitor terminals.
8. Remove the 2 screws which fasten the control box.(See Figure 19)
9. Pull the control box forward completely.
10. Re-install the components by referring to the removal procedure, above. (See Figure 19)

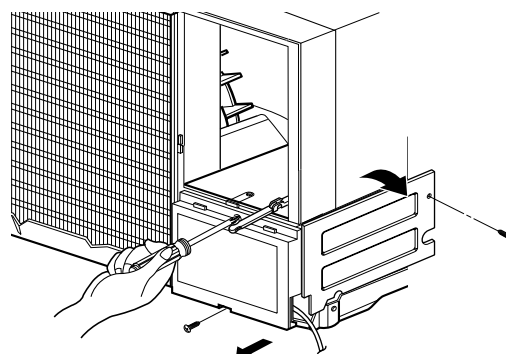

Figure 19

## Air Handling Parts

### 1. AIR GUIDE AND BLOWER

1. Remove the front grille.
2. Remove the cabinet.
3. Remove the control box.
4. Remove the 3 screws which fasten the brace.
5. Remove the brace.
6. Remove the 2 screws which fasten the evaporator.
7. Move the evaporator forward and pulling it upward slightly. (See Figure 20)
8. Move the evaporator to the left carefully.
9. Pull out the hook of orifice by pushing the tabs and remove it. (See Figure 21)
10. Remove the clamp with a hand plier which secures the blower.
11. Remove the blower.
12. Remove the 4 screws which fasten the air guide from the barrier.
13. Move the air guide backward, pulling out from the base pan.
14. Re-install the components by referring to the removal procedure, above.

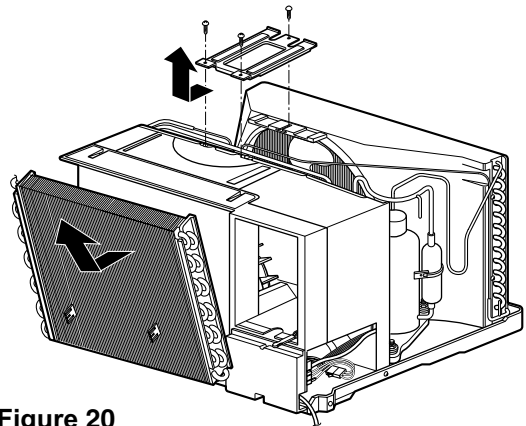

Figure 20

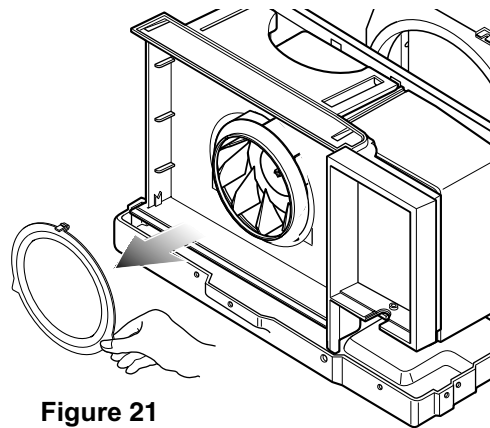

Figure 21

### 2. FAN AND SHROUD

1. Remove the cabinet.
2. Remove the brace.
3. Remove the 3 screws which fasten the condenser.
4. Move the condenser to the left carefully.
5. Remove the clamp which secures the fan.
6. Remove the fan and then pull out the shroud. (See Figure 22)
7. Re-install by referring to the removal procedure.

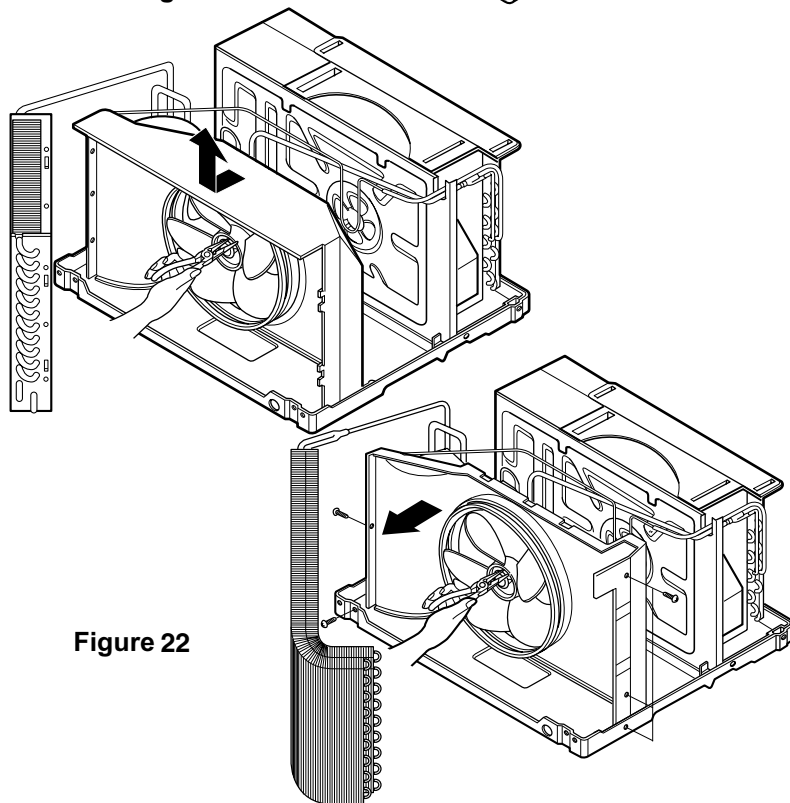

Figure 22

### 3. MOTOR

1. Remove the cabinet.
2. Remove the evaporator.
3. Remove the orifice.
4. Remove the blower.
5. Remove the fan.
6. Remove the control box cover and housing of the motor in the control box.
7. Remove the 2 screws which fasten the motor from the mount motor. (See Figure 23)
8. Remove the motor.
9. Re-install the components by referring to the removal procedure, above.(See Figure 23)

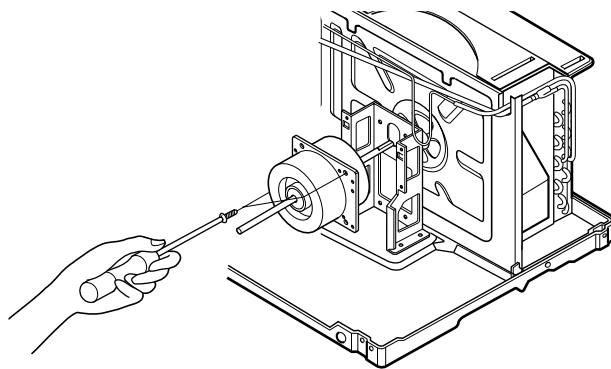

Figure 23

## Electrical Parts

### 1. OVERLOAD PROTECTOR

1. Remove the cabinet.
2. Remove the nut which fastens the terminal cover.
3. Remove the terminal cover. (See Figure 24)
4. Remove all the leads from the overload protector.
5. Remove the overload protector.
6. Re-install the component by referring to the removal procedure, above.

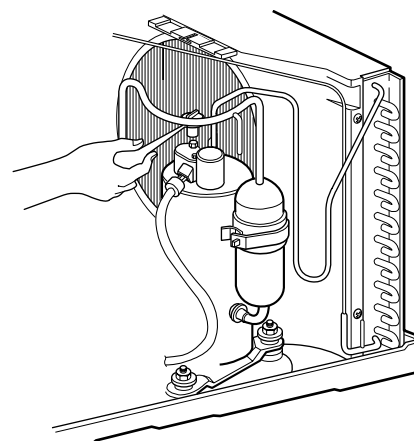

Figure 24

### 2. COMPRESSOR

1. Remove the cabinet.
2. Discharge the refrigerant system using a Freon™ Recovery System.  
If there is no valve to attach the recovery system, install one (such as a WATCO A-1) before venting the Freon™. Leave the valve in place after servicing the system.
3. Remove the overload protector.
4. After purging the unit completely, unbrazed the suction and discharge tubes at the compressor connections.
5. Remove the 3 nuts and the 3 washers which fasten the compressor.
6. Remove the compressor. (See Figure 25)
7. Re-install the components by referring to the removal procedure, above.

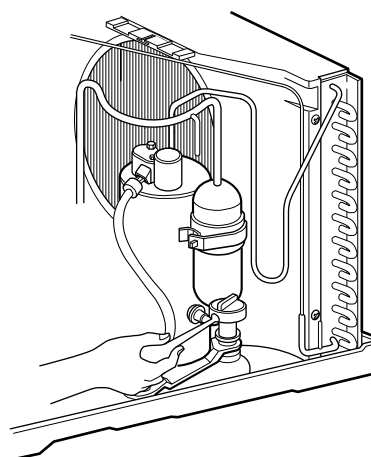

Figure 25

### 3. CAPACITOR

1. Remove the control box.
2. Remove the screw which fasten control panel from control box.
3. Remove the screw which located in the front.
4. Open the bottom side of control box.
5. Remove the screw and the clamp which fastens the capacitor.
6. Disconnect all the leads of capacitor terminals.
7. Re-install the components by referring to the removal procedure, above. (See Figure 26)

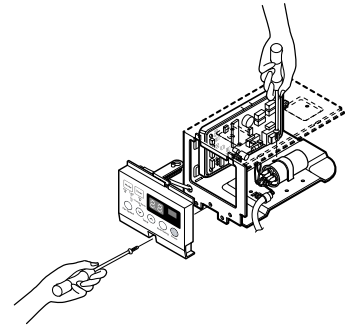

Figure 26

### 4. POWER CORD

1. Remove the control box.
2. Open the control box.
3. Disconnect the grounding screw from the control box.
4. Disconnect the 2 receptacles.
5. Remove a screw which fastens the clip cord. (See Figure 27)
6. Remove the power cord.
7. Re-install the component by referring to the above removal procedure, above. (Use only one ground-marked hole  $\oplus$  for ground connection.)
8. If the supply cord of this appliance is damaged, it must be replaced by the special cord. (The special cord means the cord which has the same specification marked on the supply cord attached at the unit.)

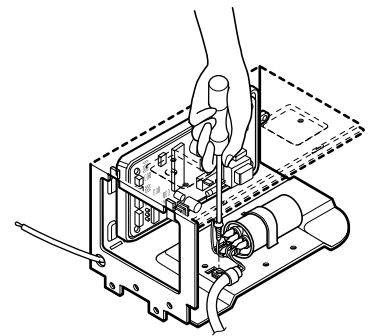

Figure 27

## Refrigerating Cycle



**CAUTION:** Discharge the refrigerant system using a Freon™ Recovery System. If there is no valve to attach the recovery system, install one (such as a WATCO A-1) before venting the Freon™. Leave the valve in place after servicing the system.

### 1. CONDENSER

1. Remove the cabinet.
2. Remove the 3 screws which fasten the brace.
3. Remove the 3 screws which fasten the condenser and shroud.
4. After discharging the refrigerant completely, unbraid the interconnecting tube at the condenser connections.
5. Remove the condenser carefully.
6. Re-install the component by referring to notes. (See Figure 28)

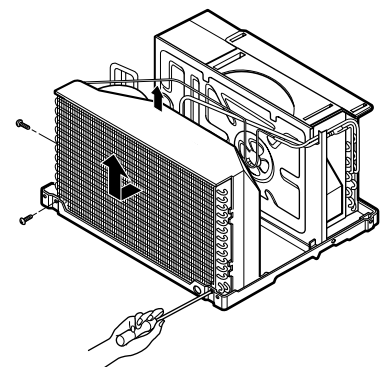

Figure 28

## 2. EVAPORATOR

1. Remove the cabinet.
2. Remove the 2 screws which fasten the evaporator.
3. Move the evaporator sideways carefully.
4. After discharging the refrigerant completely, unbrazed the interconnecting tube at the evaporator connections.
5. Remove the evaporator carefully.
6. Re-install the component by referring to notes. (See Figure 29)

## 3. CAPILLARY TUBE

1. Remove the cabinet.
2. After discharging the refrigerant completely, unbrazed the interconnecting tube at the capillary tube.
3. Remove the capillary tube.
4. Re-install the component by referring to notes.

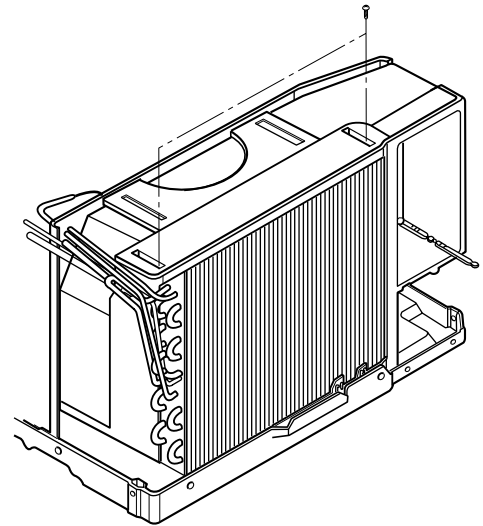

Figure 29

### NOTICE

— Replacement of the refrigeration cycle.

1. When replacing the refrigeration cycle, be sure to discharge the refrigerant system using a Freon™ recovery System. If there is no valve to attach the recovery system, install one (such as a WATCO A-1) before venting the Freon™. Leave the valve in place after servicing the system.
2. After discharging the unit completely, remove the desired component, and unbrazed the pinch-off tubes.
3. Solder service valves into the pinch-off tube ports, leaving the valves open.
4. Solder the pinch-off tubes with Service valves.
5. Evacuate as follows.
  - 1) Connect the vacuum pump, as illustrated figure 30A.
  - 2) Start the vacuum pump, slowly open manifold valves A and B with two full turns counterclockwise and leave the valves open. The vacuum pump is now pulling through valves A and B up to valve C by means of the manifold and entire system.

**CAUTION:** If high vacuum equipment is used, just crack valves A and B for a few minutes, then open slowly with the two full turns counterclockwise. This will keep oil from foaming and being drawn into the vacuum pump.

- 3) Operate the vacuum pump vacuum for 20 to 30 minutes, until 600 microns of vacuum is obtained. Close valves A and B, and observe vacuum gauge for a few minutes. A rise in pressure would indicate a possible leak or moisture

remaining in the system. With valves A and B closed, stop the vacuum pump.

- 4) Remove the hose from the vacuum pump and place it on the charging cylinder. See figure 37B. Open valve C. Discharge the line at the manifold connection.
- 5) The system is now ready for final charging.
6. Recharge as follows :
  - 1) Refrigeration cycle systems are charged from the High-side. If the total charge cannot be put in the High-side, the balance will be put in the suction line through the access valve which you installed as the system was opened.
  - 2) Connect the charging cylinder as shown in figure 30B. With valve C open, discharge the hose at the manifold connection.
  - 3) Open valve A and allow the proper charge to enter the system. Valve B is still closed.
  - 4) If more charge is required, the high-side will not take it. Close valve A.
  - 5) With the unit running, open valve B and add the balance of the charge.
    - a. Do not add the liquid refrigerant to the Low-side.
    - b. Watch the Low-side gauge; allow pressure to rise to 30 lbs.
    - c. Turn off valve B and allow pressure to drop.
    - d. Repeat steps b. and c. until the balance of the charge is in the system.
  - 6) When satisfied the unit is operating correctly, use the pinch-off tool with the unit still running and clamp on to the pinch-off tube. Using a tube cutter, cut the pinch-off tube about 2 inches from the pinch-off tool. Use sil-fos braze and braze pinch-off tube closed. Turn off the unit, allow it to set for a while, and then test the leakage of the pinch-off connection.

**Equipment needed:** Vacuum pump, Charging cylinder, Manifold gauge, Brazing equipment. Pin-off tool capable of making a vapor-proof seal, Leak detector, Tubing cutter, Hand Tools to remove components, Service valve.

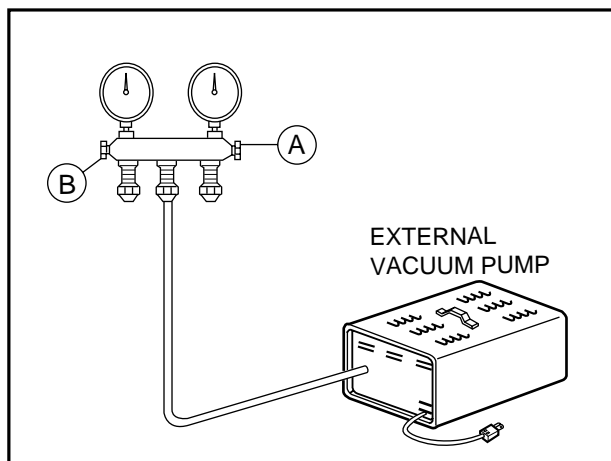
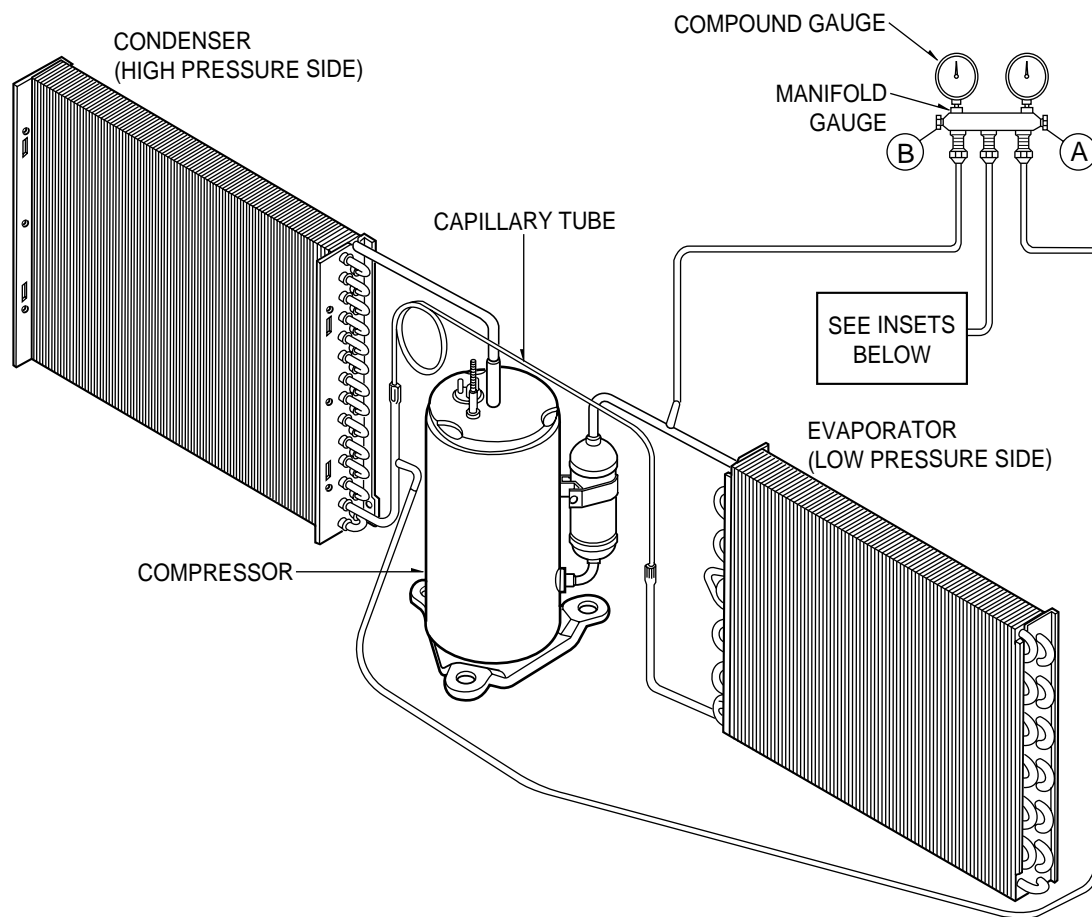

Figure 30A-Pulling Vacuum

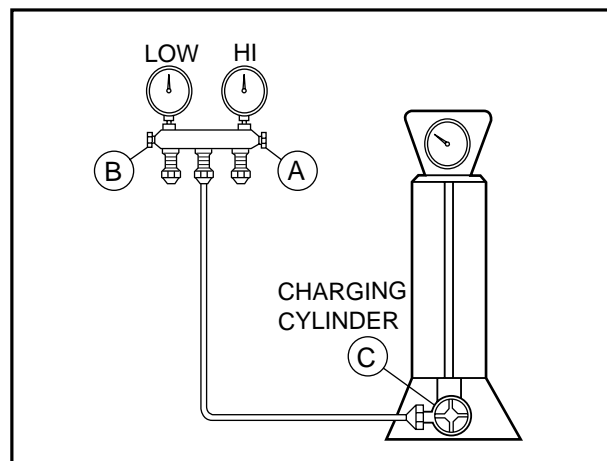
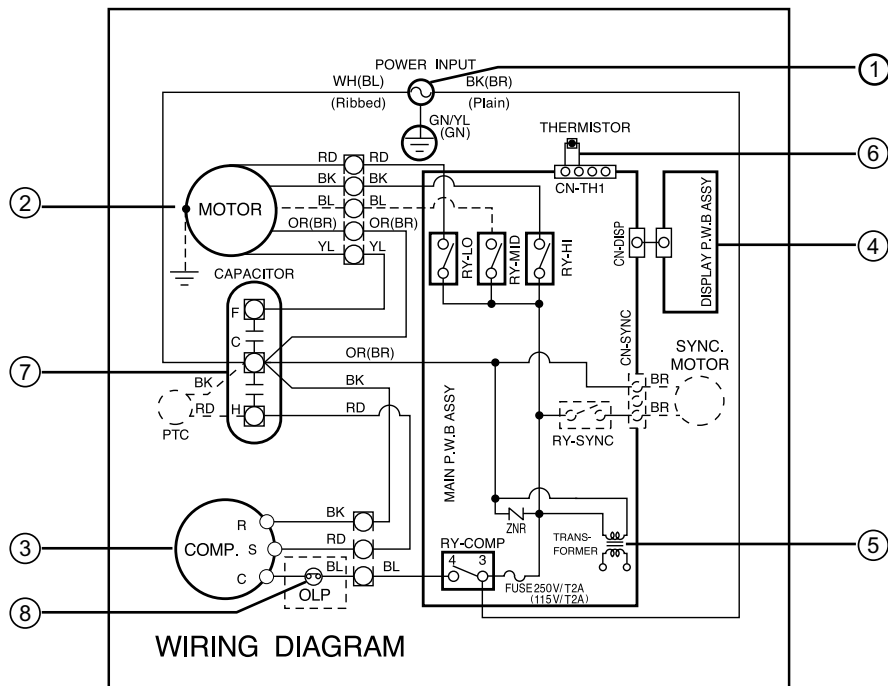

Figure 30B-Charging



## Circuit Diagram



LOCATION NO.	DESCRIPTION	Q'TY PER SET
1	POWER CORD ASSEMBLY	1
2	FAN MOTOR	1
3	COMPRESSOR	1
4	DISPLAY P.W.B ASSEMBLY	1
5	MAIN P.W.B ASSEMBLY	1
6	THERMISTOR	1
7	CAPACITOR	1
8	OWERLOAD PROTECTOR	1





# Troubleshooting Guide

## Piping System

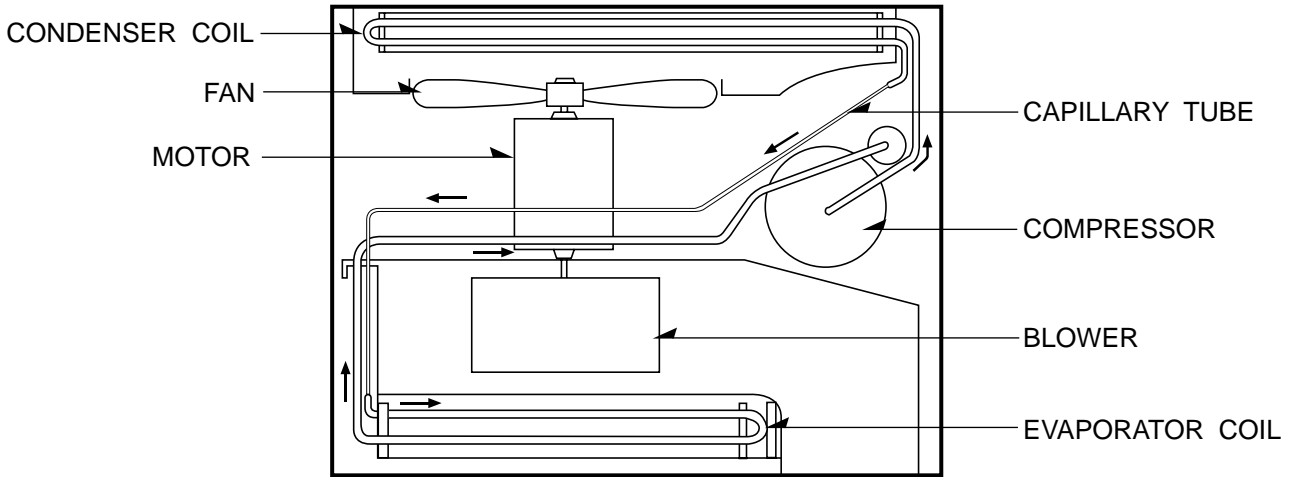
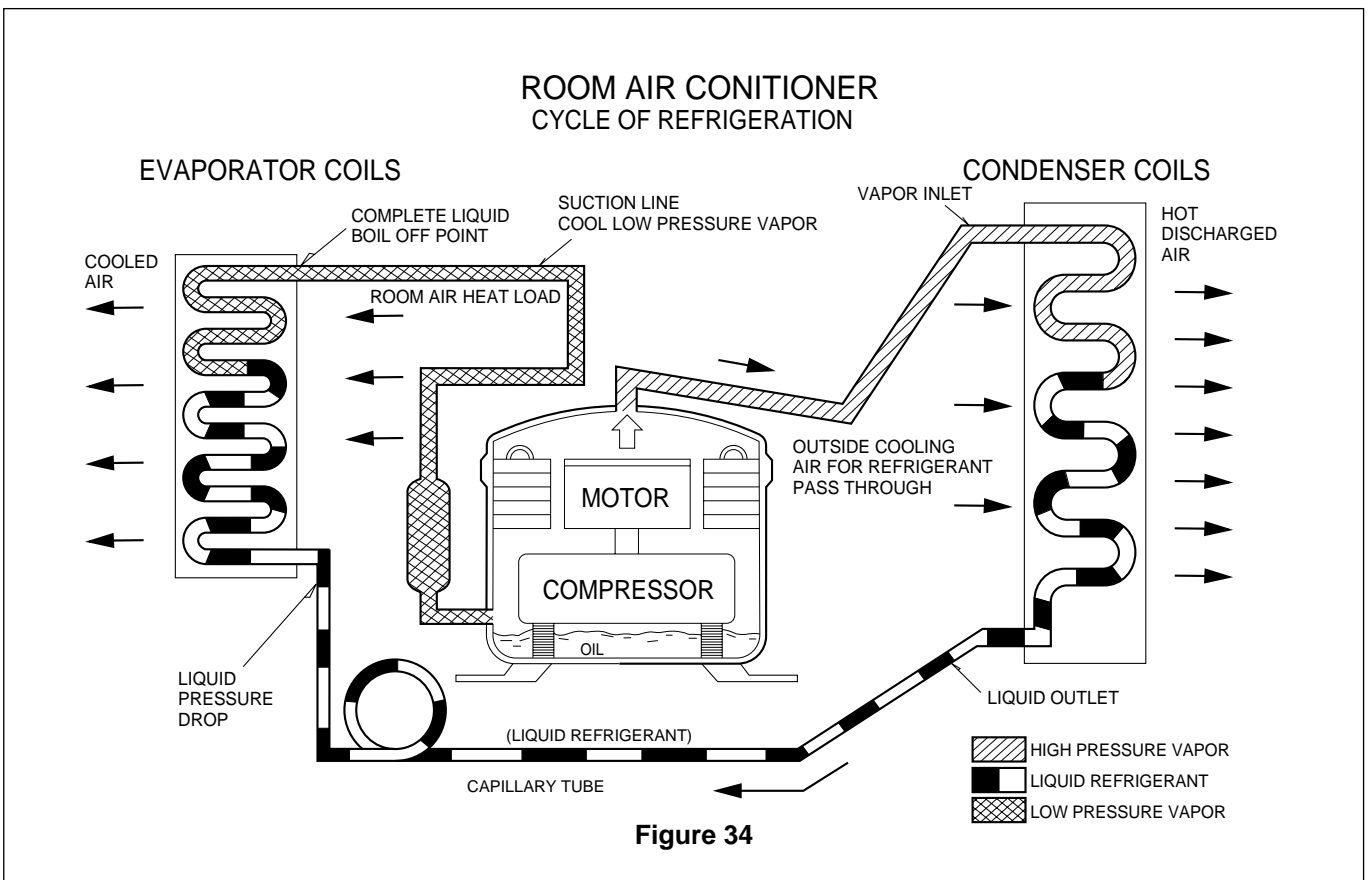

Figure 38 is a brief description of the important components and their function in what is called the refrigeration system. This will help you to understand the refrigeration cycle and the flow of the refrigerant in the cooling cycle.



## Troubleshooting Guide

In general, possible trouble is classified in two kinds.

The one is called Starting Failure which is caused from an electrical defect, and the other is ineffective Air Conditioning caused by a defect in the refrigeration circuit and improper application.

### Unit runs but poor cooling.

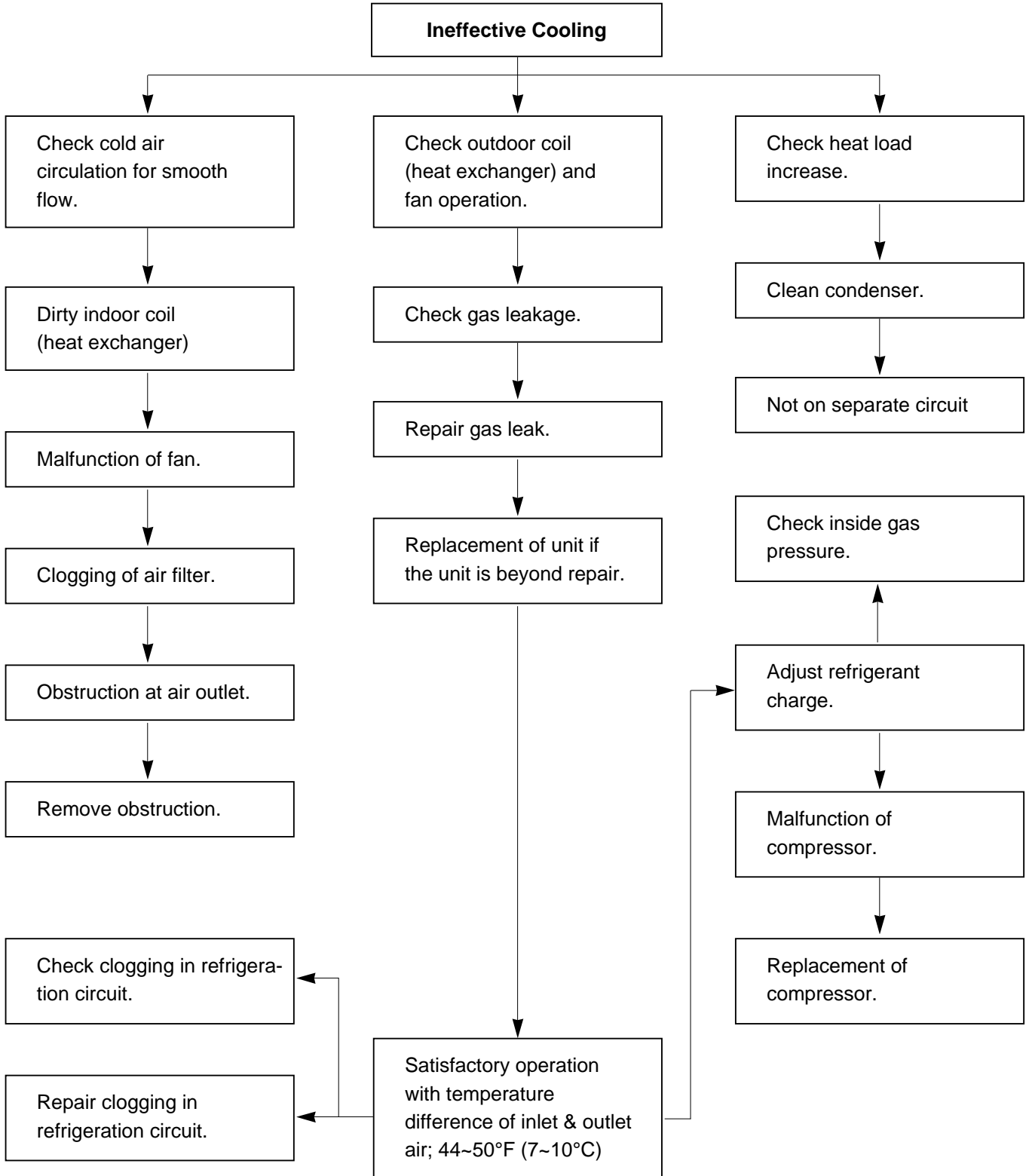

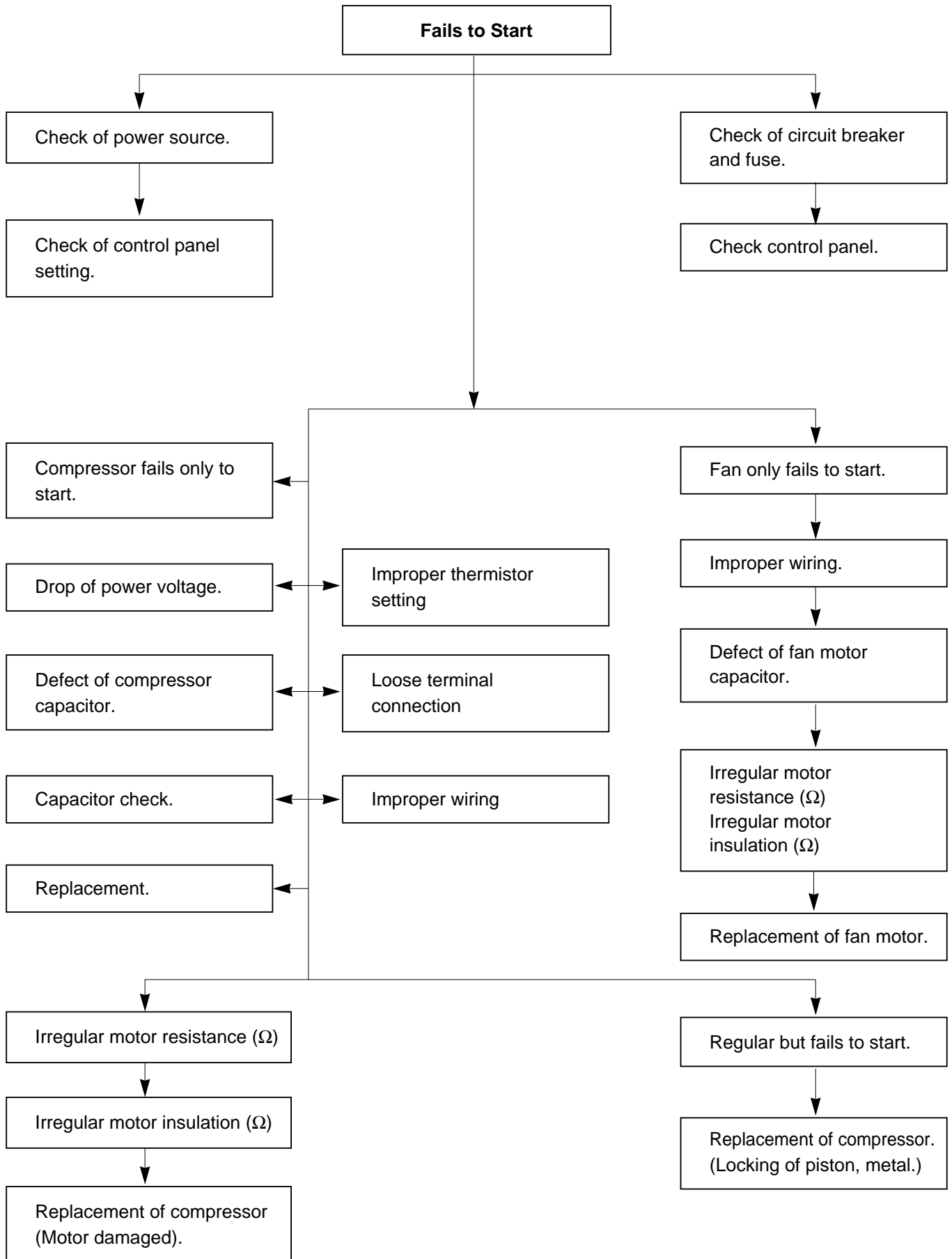

**ELECTRIC PARTS TROUBLESHOOTING GUIDE:**

**Possible Trouble 1**

• The unit does not operate.

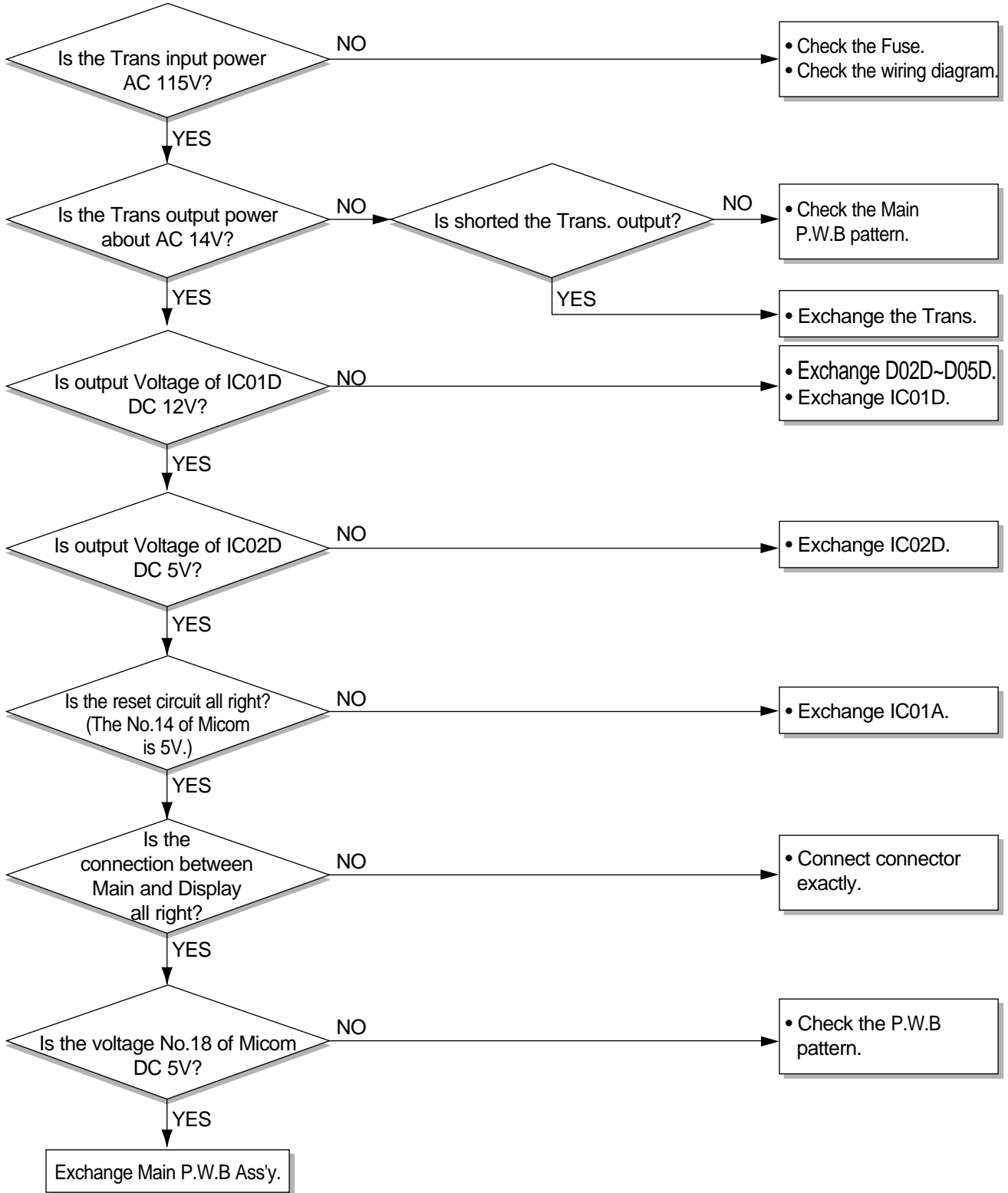

**Possible Trouble 2**

• The compressor does not operate.

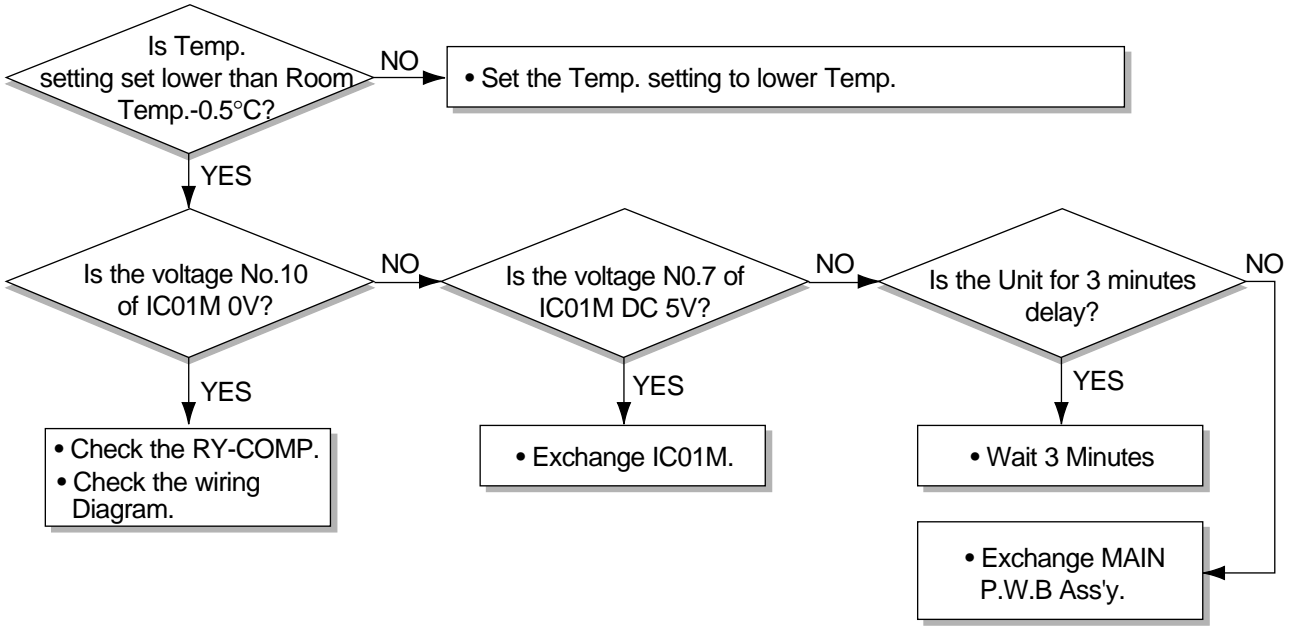

**Possible Trouble 3**

• The compressor always operate.



**Possible Trouble 4**

• Fan does not operate.

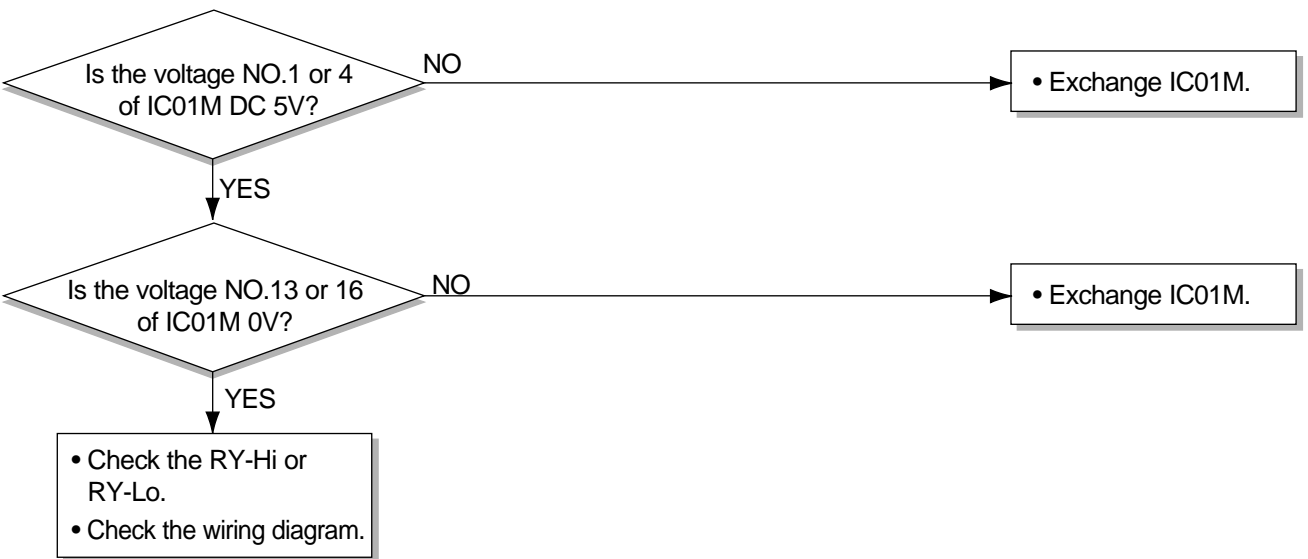



**Possible Trouble 5**

• Remote controller does not operate.

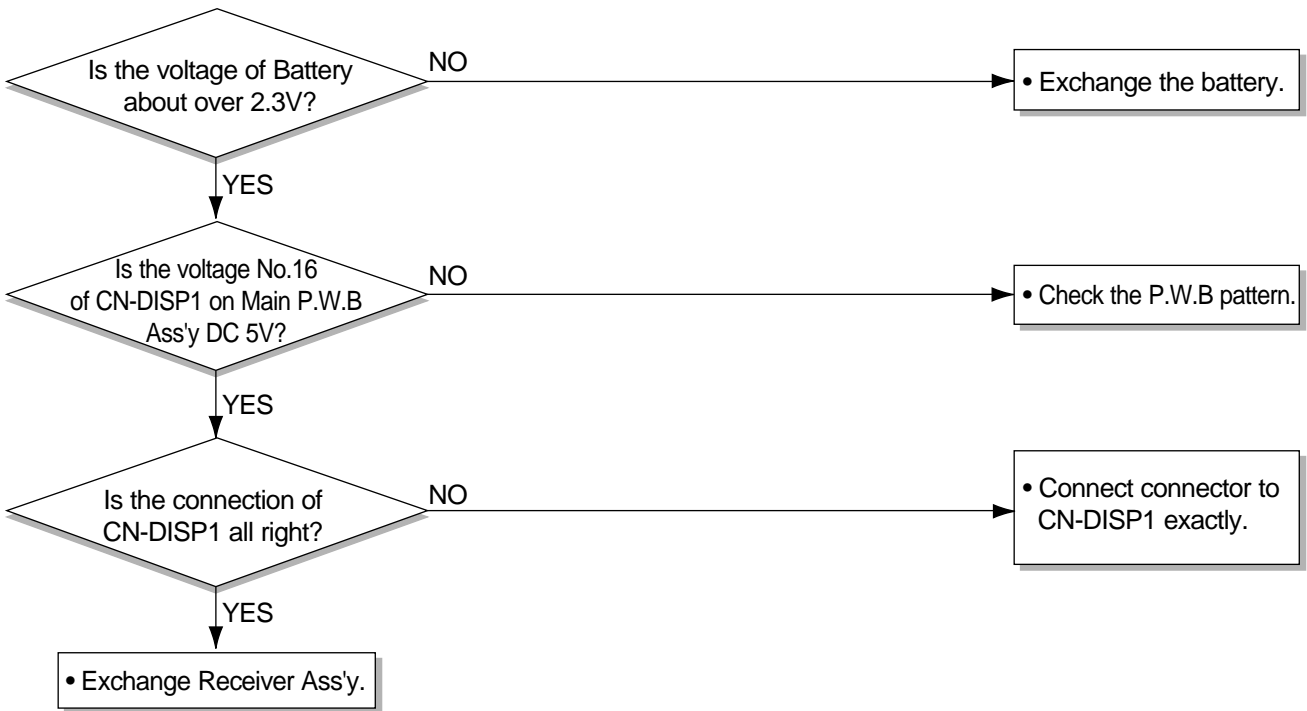

**Possible Trouble 6**

• It displays abnormally on Display P.W.B Ass'y.

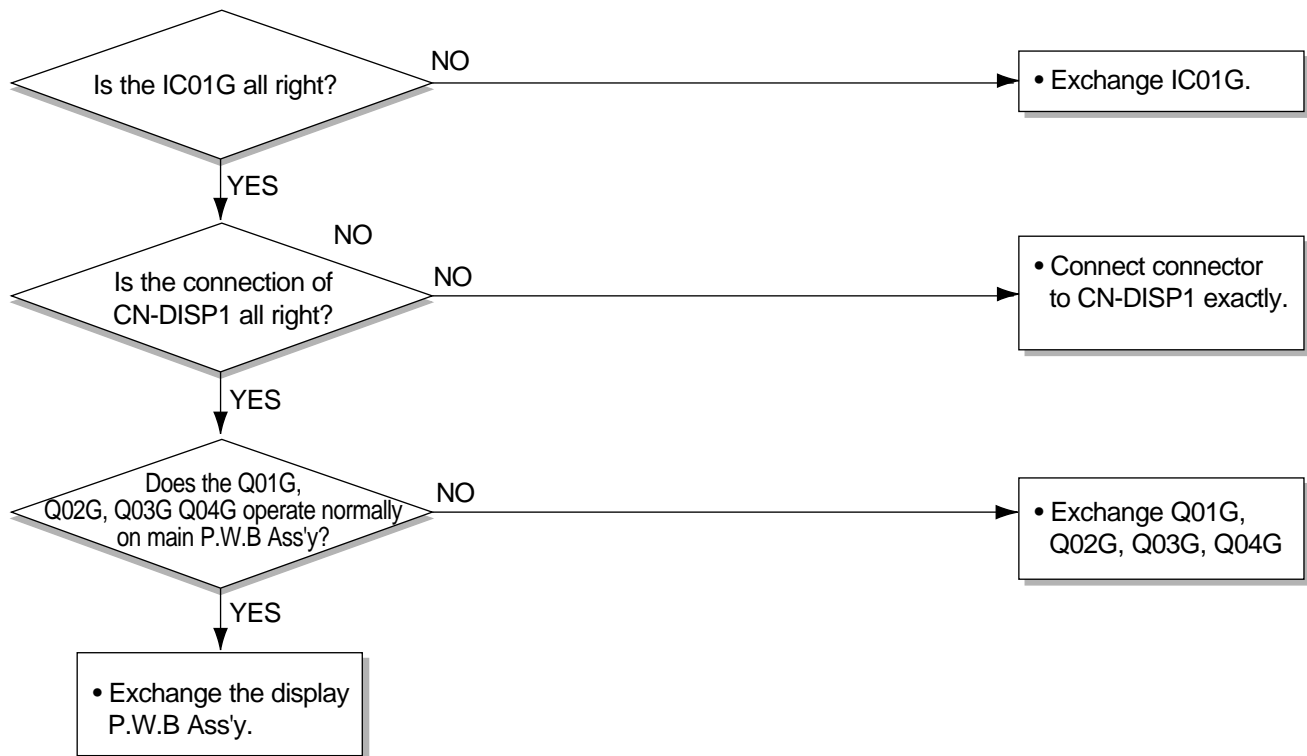

**ROOM AIR CONDITIONER VOLTAGE LIMITS**

NAME PLATE RATING	MINIMUM	MAXIMUM
115V ± 10%	103.5V	126.5V

COMPLAINT	CAUSE	REMEDY
Fan motor will not run.	No power	Check voltage at outlet. Correct if none.
	Power supply cord	Check voltage to rotary switch. If none, check power supply cord. Replace cord if circuit is open.
	Rotary switch	Check switch continuity. Refer to wiring diagram for terminal identification. Replace switch if defective.
	Wire disconnected or connection loose	Connect wire. Refer to wiring diagram for terminal identification. Repair or replace loose terminal.
	Capacitor (Discharge capacitor before testing.)	Test capacitor. Replace if not within ±10% of manufacturer's rating. Replace if shorted, open, or damaged.
	Will not rotate	Fan blade hitting shroud or blower wheel hitting scroll. Re-align assembly.  Units using slinger ring condenser fans must have 0.22~0.25 inch clearance to the base. If necessary, shim up the bottom of the fan motor with mounting screw(s).  Check fan motor bearings; if motor shaft will not rotate, replace the motor.
Fan motor runs.	Revolves on overload	Check voltage. See limits on this page.  If not within limits, call an electrician.  Test capacitor. Check bearings. Does the fan blade rotate freely? If not, replace fan motor.  Pay attention to any change from high speed to low speed. If the speed does not change, replace the motor.

COMPLAINT	CAUSE	REMEDY
Fan motor noise.	Fan	If cracked, out of balance, or partially missing, replace it.
	Blower	If cracked, out of balance, or partially missing, replace it.
	Loose set screw	Tighten it.
	Worn bearings	If knocking sounds continue when running or loose, replace the motor. If the motor hums or noise appears to be internal while running, replace motor.
Compressor will not run, fan motor runs.	Voltage	Check voltage. See the limits on the preceding page. If not within limits, call an electrician.
	Wiring	Check the wire connections; if loose, repair or replace the terminal. If the wires are disconnected, refer to wiring diagram for identification, and replace the wires. Check the wire connections; If not according to the wiring diagram, correct the connections.
	Thermistor	Check the TEMP control. If not at the lowest number, set TEMP control to this setting and restart the unit.
		Check the continuity of the thermistor. Replace the thermistor if the circuit is open.
	Rotary	Check for continuity, refer to the wiring diagram for terminal identification. Replace the switch if the circuit is open.
	Thermostat	Check the position of knob. If not at the coldest setting, advance the knob to this setting and restart the unit.
		Check the continuity of the thermostat. Replace the thermostat if the circuit is open.
	Capacitor (discharge capacitor before servicing.)	Check the capacitor. Replace if not within $\pm 10\%$ of manufacturer's rating, replace if shorted, open, or damaged.
	Compressor	Check the compressor for open circuit or ground. If open or grounded, replace the compressor.
Overload	Check the compressor overload if externally mounted. Replace if open. (If the compressor temperature is high, remove the overload, cool, and retest.)	

COMPLAINT	CAUSE	REMEDY
Compressor cycles on overload.	Voltage	Check the voltage. See the limits on the preceding page. If voltage is not within these limits, call an electrician.
	Overload	Check overload, if externally mounted. Replace if open. (If the compressor temperature is high, remove the overload, cool, and retest.)
Compressor cycles on overload.	Fan motor	If not running, determine the cause. Replace if required.
	Condenser air flow restriction	Remove the cabinet, inspect the interior surface of the condenser. If restricted, clean carefully with a vacuum cleaner (do not damage fins) or brush. Clean the interior base before re-assembling.
	Condenser fins (damaged)	If the condenser fins are closed over a large area on the coil surface, head pressures will increase, causing the compressor to cycle. Straighten the fins or replace the coil.
	Capacitor	Test the capacitor.
	Wiring	Check the terminals. If loose, repair or replace.
	Refrigeration system	Check the system for a restriction.
Insufficient cooling	Air filter	If restricted, clean or replace.
	Unit undersized	Determine if the unit is properly sized for the area to be cooled.
Excessive noise	Blower or fan	Check the set screw, or clamp. If loose or missing, correct. If the blower or fan is hitting scroll or barrier, rearrange the air handling parts.
	Copper tubing	Remove the cabinet and carefully rearrange the tubing not to contact the cabinet, compressor, shroud, and barrier.

# Exploded View

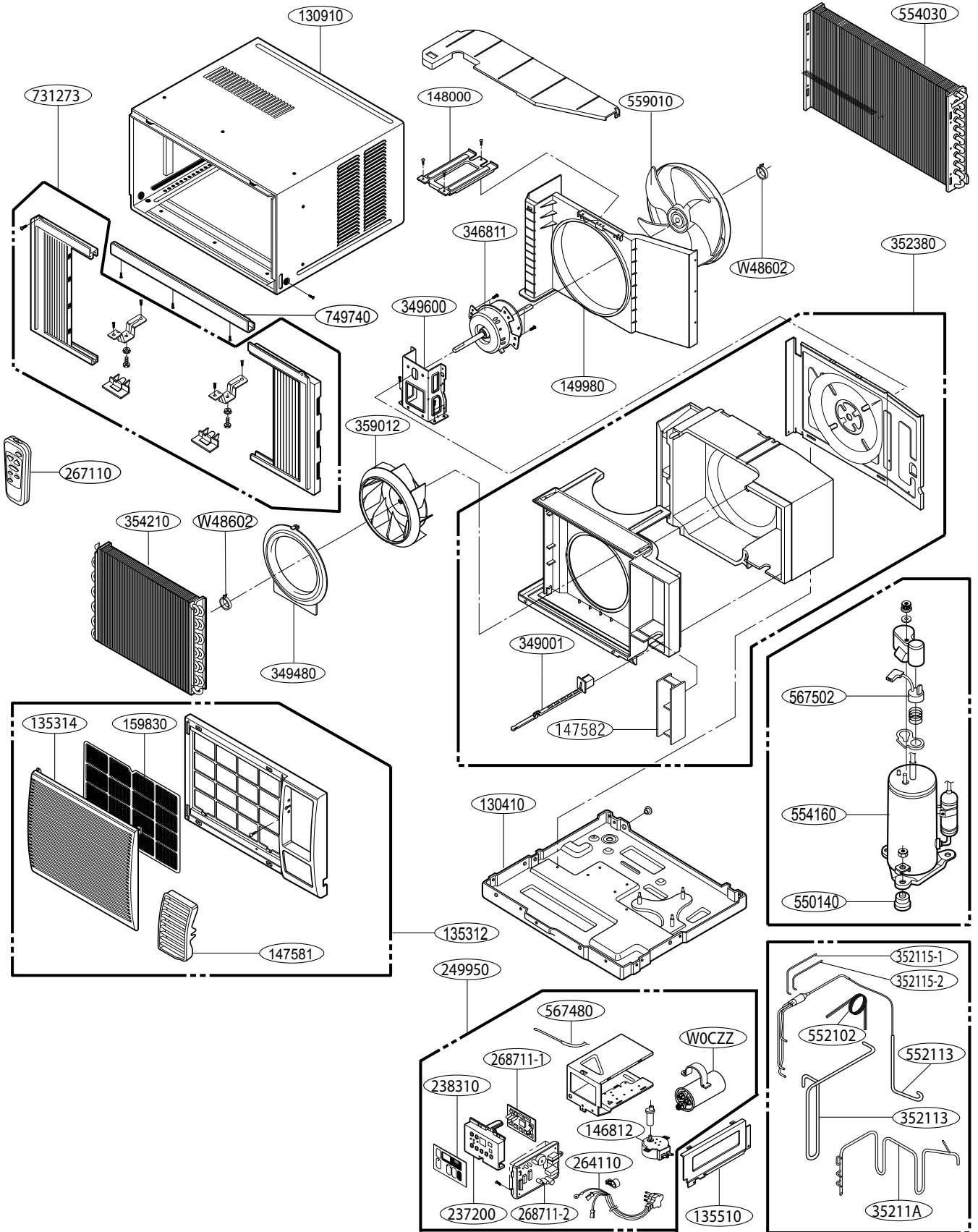

Replacement Parts list

LocNo	CP06E10	CP08E10	DESCRIPTION	REMARK
130410	67302912	67302905	Base Assy Single	R
349001	67303502	67303502	Damper Assembly	R
130910	67303714	67303714	Cabinet Assy Single	R
135312	67306017	67306017	Grille Assy Front	R
135314	67306110	67306110	Grille Assy Inlet	R
135510	67400148	67400148	Cover	R
147581	67306208	67306208	Louver,Horizontal	R
147582	67306264	67306264	Louver,Vertical	R
149980	67303108	67303104	Shroud	R
159830	67304309	67304309	Filter (Mech)	R
238310	67500142	67500142	Escutcheon	R
567480	67307806	67307806	Thermistor	R
264110	67300020	67300020	Power Cord Assy	R
267110	67307704	67307704	Remote Controller	R
249950	67305511	67305513	Case Assembly,Control	R
237200	67305512	67305512	Panel,Control	R
268711-1	67307621	67307621	PWB(PCB) Assy Display	R
268711-2	67307622	67307622	PWB(PCB) Assy Main	R
146812	67300902	67300902	Swing Louver Motor	R
349600	67303604	67303604	Bracket,Motor	R
346811	67303013	67303005	Motor Assy Single	R
349480	67303412	67303412	Orifice	R
352380	67302736	67302736	Duct Assembly	R
552102	67400188	67400190	Tube Assy Capillary	R
550140	67301900	67301901	Isolator Comp	R
559010	67303203	67303203	Fan Assy Axial	R
359012	67302609	67302609	Fan Turbo	R
148000	67303901	67303901	Supporter	R
567502	67301405	67301406	O.L.P. Overload Protect	R
W0CZZ	67300718	67302726	Capacitor	R
731273	67306312	67306312	installation Kit w/Curtain	R
W48602	67302500	67302500	Clamp Spring	R
749740	67304002	67304002	Upper Guide Cabinet	R

# Use Factory Certified Parts...

***Friedrich***<sup>®</sup>

FRIEDRICH AIR CONDITIONING CO.

Visit our web site at [www.friedrich.com](http://www.friedrich.com)

Post Office Box 1540 • 4200 N. Pan Am Expressway • San Antonio, Texas 78295-1540  
• (210) 357-4400 • FAX (210) 357-4490

CP06 CP08 SVC PARTS 2008(07/08)