

This Owner's Manual is provided and hosted by [Appliance Factory Parts](#).

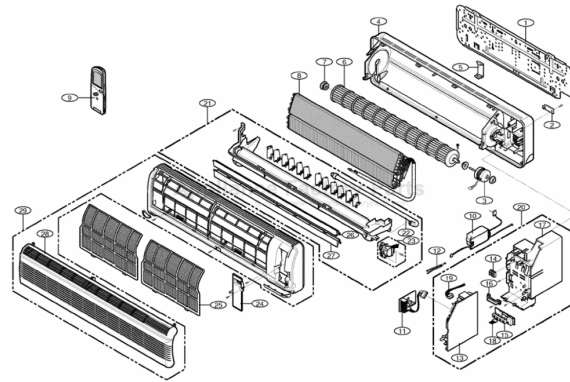

LG AG1AC23BWI Owner's Manual

[Shop genuine replacement parts for LG AG1AC23BWI](#)



[Find Your LG Air Conditioner Parts - Select From 2328 Models](#)

----- Manual continues below -----

Refrigeration Cycle Diagram

• Cooling Only Models

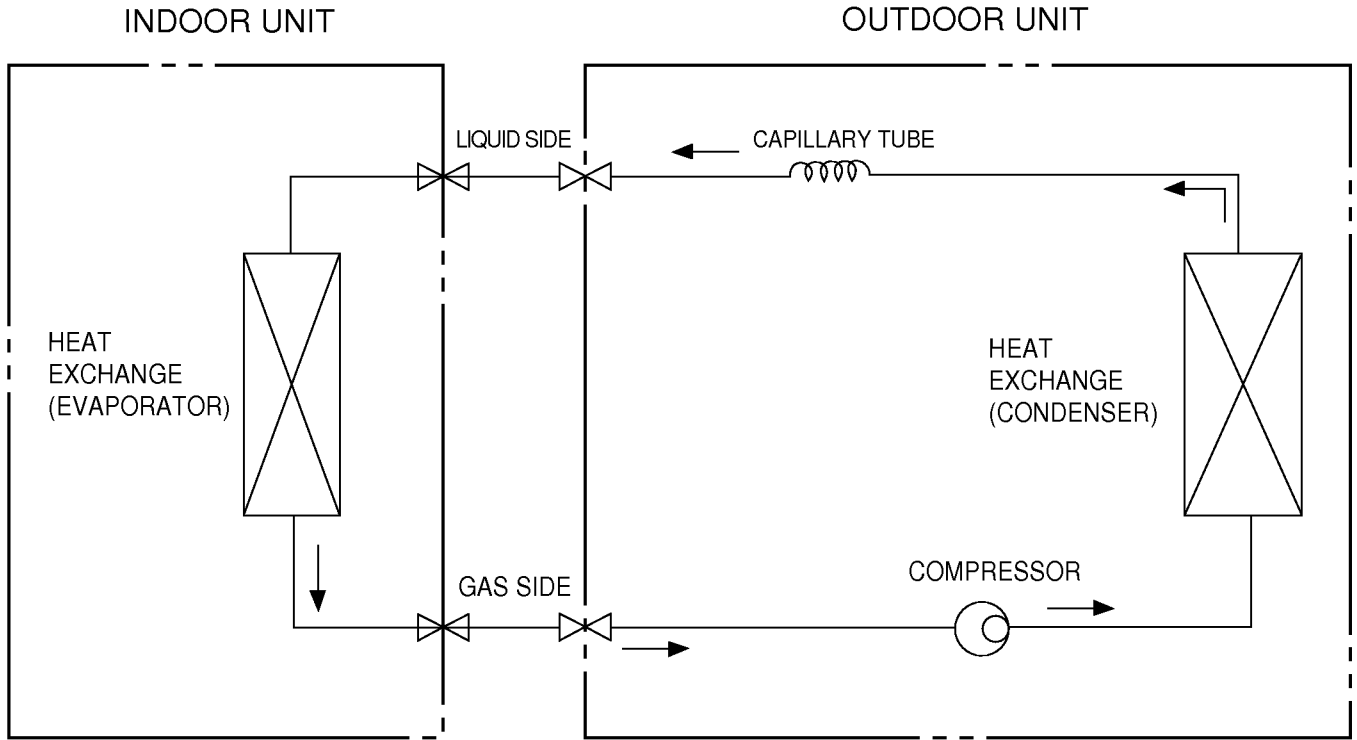

MODEL	Pipe size(Diameter:ø)		Piping length(m)		Elevation(m)	
	Gas	Liquid	Rated	Max	Rated	Max
17K	1/2"	1/4"	7	15	5	8
23K	5/8"	1/4"	7	15	5	8

For installation over rated distance, 40g of refrigerant should be added for each meter.

ex) When installed at a distance of 15m, 320g of refrigerant should be added.

$$(15-7) \times 40g = 320g$$

• Cooling & Heating Models

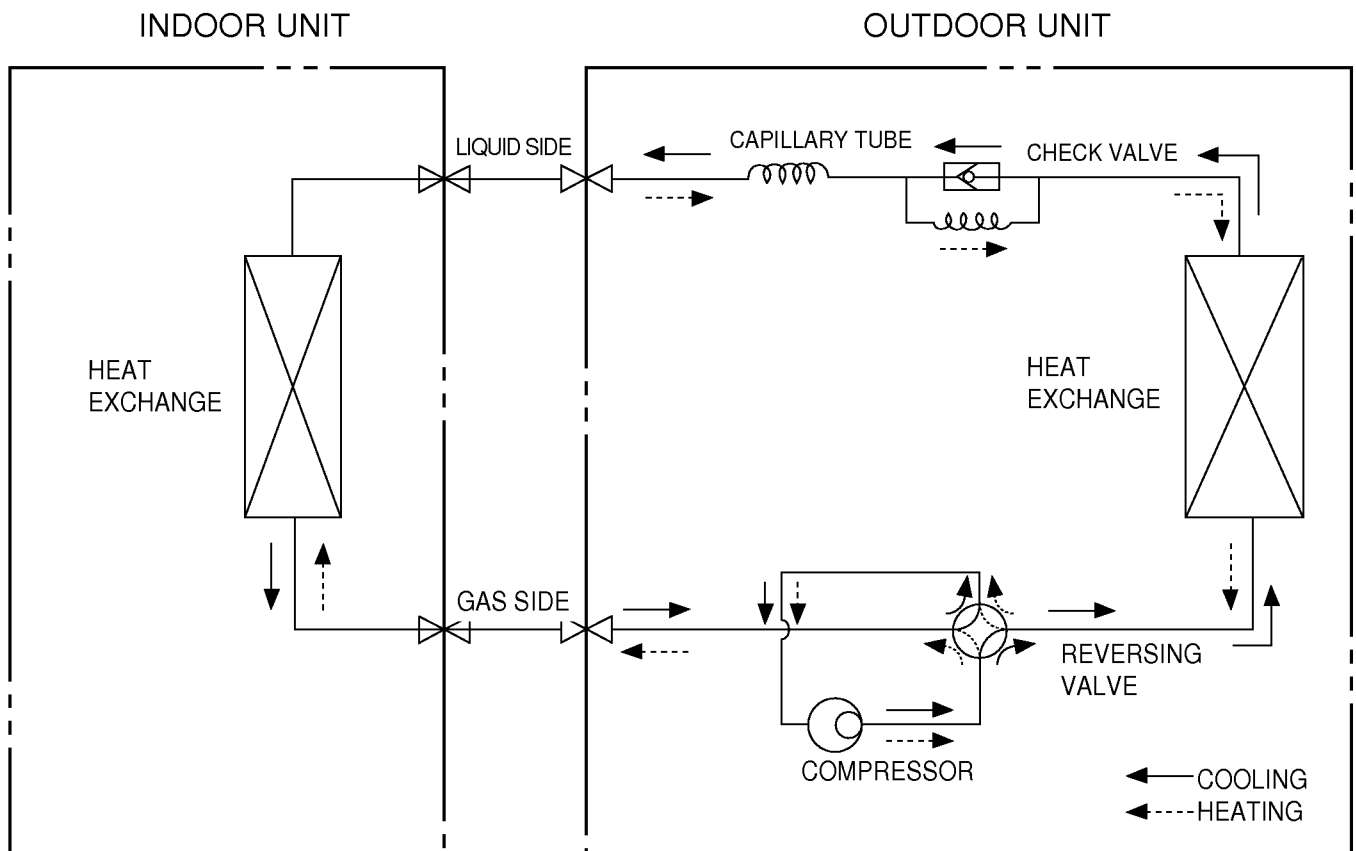

MODEL	Pipe size(Diameter:ø)		Piping length(m)		Elevation(m)	
	Gas	Liquid	Rated	Max	Rated	Max
17K	1/2"	1/4"	7	15	5	8
23K	5/8"	1/4"	7	15	5	8

For installation over rated distance, 40g of refrigerant should be added for each meter.

ex) When installed at a distance of 15m, 320g of refrigerant should be added.

$$(15-7) \times 40g = 320g$$

Wiring Diagram

(1) Indoor Unit

1. AG1AC17BKM01, AG1AC23BKM01

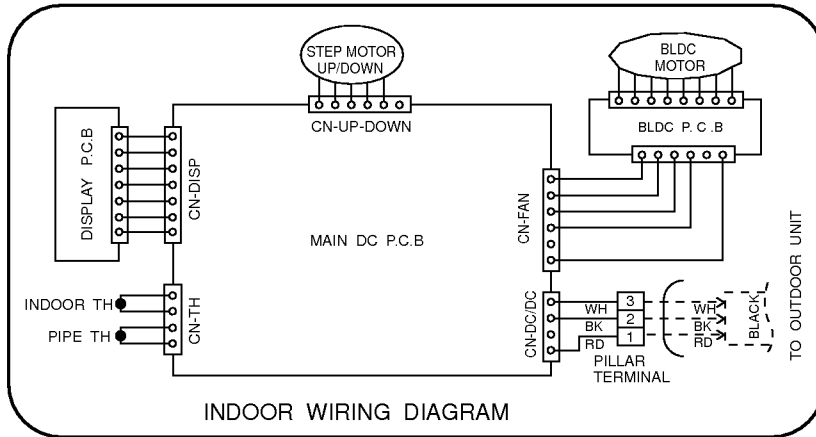

2. AG1AC17BWF/G/I, AG1AC23BWF/G/I, AG1AH17BWF/G/I, AG1AH23BWF/G/I

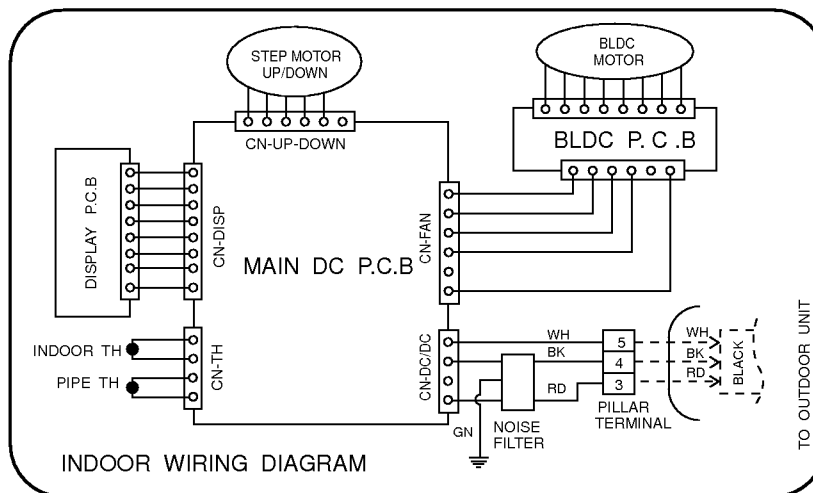

(2) Outdoor Unit

1. AG0AC17BWOR1, AG0AC17BKOD1, AG0AC23BKOR1

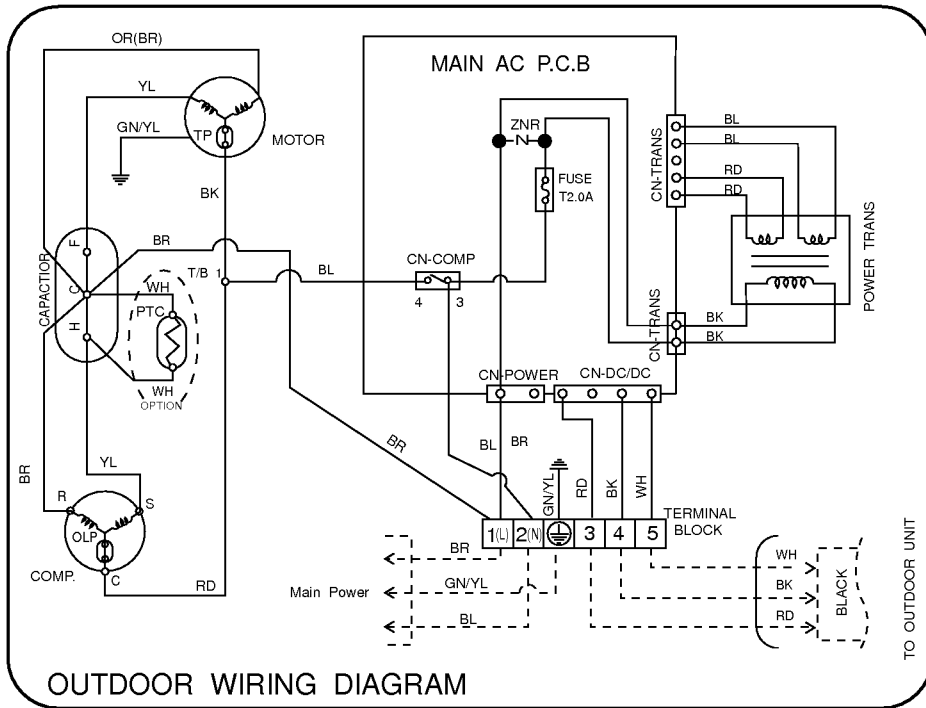

2. AG0AC23BWOR1

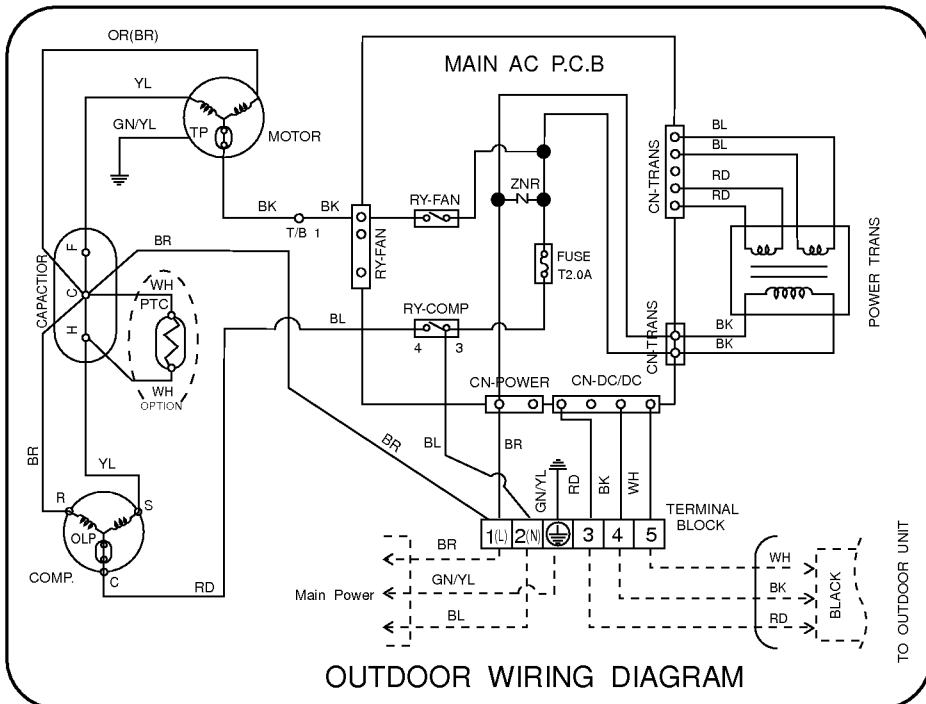

3. AG0AH17BWOR1, AG0AH23BWOR1, AG0AH17BKOR1, AG0AH23BKOR1

