

This Owner's Manual is provided and hosted by [Appliance Factory Parts](#).



Charmglow - Old 720-0578 - Old Owner's Manual

[Shop genuine replacement parts for Charmglow - Old
720-0578 - Old](#)



[Find Your Charmglow - Old Grill Parts - Select From 3 Models](#)

----- Manual continues below -----

ASSEMBLY & OPERATING INSTRUCTIONS



Model: 720-0578

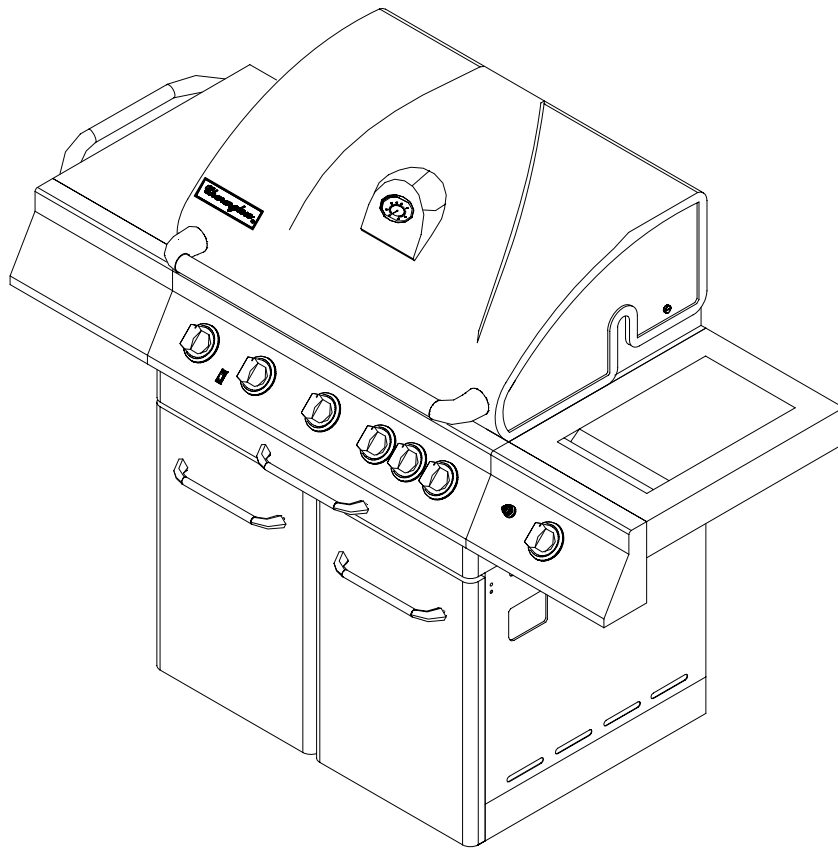

FOR OUTDOOR USE ONLY

FOR PROPANE GAS USE ONLY

G09Y07P-1

This instructions manual contains important information necessary for the proper assembly and safe use of the appliance.

Read and follow all warnings and instructions before assembling and using the appliance





Follow all warnings and instructions when using the appliance

Keep this manual for future reference

Table of Contents

Safety Instruction	3-7	Exploded View	29
Assembly Instruction	8-11	Part List	30-31
To Match Light the Grill	12	Converting to Natural Gas	32
Gas Hook –Up	13-14	Instruction for Converting to Natural Gas . . .	33
Installer Final Check List	14	Gas Conversion	34-40
Leak Testing	15-16	Ordering Parts	41
Operating Instruction	17-18	Grill Hints	41
Grill Lighting Instruction	18-20	Grill Cooking Chart	42-44
Lighting Illustration	21	Grill Recipe Suggestion	45-47
Motor Instruction	22	Limited Warranty	48
Care and Maintenance	23-24		
Trouble Shooting	25-28		

Safety Instruction

<p> DANGER</p> <p>If you smell gas:</p> <ol style="list-style-type: none"> 1. Shut off gas to the appliance. 2. Extinguish any open flame. 3. Open lid 4. If odor continues, keep away from the appliance and immediately call you gas supplier or your fire department. 	<p> WARNING</p> <p>1.Do not store or use gasoline or other flammable vapors and liquids in the vicinity of this or any other appliance.</p> <p>2.An LP cylinder not connected for use shall not be stored in the vicinity of this or any other appliance.</p>
<p> Failure to comply with these instructions could result in a fire or explosion that could cause serious bodily injury, death, or property damage.</p> <p> Combustion by products produced when using this product contain chemicals known to the States of California to cause cancer, birth defects, or other reproductive harm</p> <p> Your grill will be very hot. Never lean over the cooking area while using your grill. Do not touch cooking surfaces, grill housing. Lid or any other grill parts while the grill is in operation, or until the gas grill has cooled down after use.</p>	



WARNING

ELECTRICAL GROUNDING INSTRUCTIONS This appliance (rotisserie motor) is equipped with a plug and should be plugged directly into a properly grounded receptacle. When installed, must be electrically grounded in accordance with local codes or in the absence of local codes, with the National Electrical Code, ANSI/NFPA 70 or the Canadian Electrical Code, CSA C22.1 DO NOT cut or remove the grounding prong from this plug.

1. To protect against electric shock, do not immerse cord or plugs in water or other liquid.
2. Unplug from the outlet when not in use and before cleaning. Allow to cool before putting on or taking off parts.
3. Do not operate any outdoor cooking gas appliance with a damaged cord, plug, or after the appliance malfunctions or has been damaged in any manner. Contact the manufacturer for repair.
4. Do not let the cord hang over the edge of a table or touch hot surface.
5. Do not use an outdoor cooking gas appliance for purposed other than intended.
6. When connecting, first connect plug to the outdoor cooking gas appliance then plug appliance into the outlet.
7. Use only a Ground Fault Interrupt (GFI) protected circuit with this outdoor cooking gas appliance.
8. Never remove the grounding plug or use with an adapter of 2 prongs.
9. Use only extension cords with a 3 prong grounding plug, rated for the power of the equipments, and approved for outdoor use with a W-A marking.



WARNING

Do not try lighting this appliance without reading the "LIGHTING INSTRUCTIONS" section of this manual.

TESTED IN ACCORDANCE WITH ANS
Z21.58 CSA 1.6-2007 STANDARD FOR
OUTDOOR COOKING GAS APPLIANCE.
THIS GRIL IS FOR OUTDOOR USE ONLY.

Grill Installation Codes

Check your local building codes for the proper method of installation. in the absence of local codes, this unit should be installed in accordance with the National Fuel Gas Code ,ANSI Z223.1/NFPA 54,Storage and Handling of Liquefied Petroleum Gases, ANSI /NFPA B149.2 or CSA B149.1 Natural Gas and Propane Installation Code, and the National Electrical Code, ANSI/NFPA 70.

Correct LP Gas Tank Use

LP gas grill models are designed for use with a standard 20 lb. Liquid Propane Gas tank, not included with grill.

Never connect your gas grill to an LP gas tank that exceeds this capacity.

If an external electrical source is utilized: The outdoor cooking gas appliance, when installed, must be electrically grounded in accordance with local codes or, in the absence of local codes, with the National Electrical Code, ANSI/NFPA 70, or the Canadian Electrical Code, CSA C22.1.

WARNING

Keep any electrical supply cord and the fuel supply hose away from any heated surfaces.

NOTE: The normal flow of gas through the regulator and hose assembly can create a humming noise. A low volume of noise is perfectly normal and will not interfere with operation of the grill. If humming noise is loud and excessive you may need to purge air from the gas line or reset the regulator excess gas flow device. This purging procedure should be done every time a new LP gas tank is connected to your grill.

CAUTION: Beware of Flashback

CAUTION: Spiders and small insects occasionally spin webs or make nest in the grill burner tubes during transit and warehousing. These webs can lead to gas flow obstruction, which could result in a fire in and around burner tubes. This type of fire is known as "FLASH-BACK" and can cause serious damage to your grill and create an unsafe operating condition for the user.

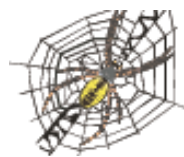

Although an obstructed burner tube is not the only cause of "FLASH-BACK", it is the most common cause.

To reduce the chance of "FLASH-BACK", you must clean the burner tubes before assembling your grill, and at least once a month in late summer or early fall when spiders are most active. Also perform this burner tube cleaning procedure if your grill has not been used for an extended period of time. A clogged tube can be lead to a fire beneath the grill.

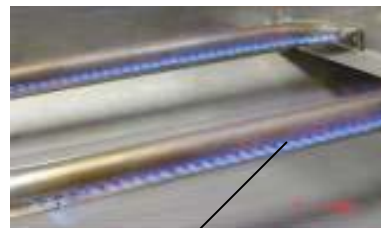

Visually check the burner flames prior to each use, the flames should look like this picture, if they do not, refer to the burner main tenancy part of this manual.

LP-Gas Supply System



- A 20lb tank of approximately 1/4 inches in diameter by 18-1/4 inches high is the maximum size LP gas tank to use.
- This safety feature prevents the tank from being overfilled, which can cause malfunction of the LP gas tank, regulator and/or grill.
- The LP gas supply cylinder to be used must be constructed and marked in accordance with the specifications for LP –Gas cylinder of the U.S. Department of Transportation (DOT) or the National Standard of Canada ,CAN/CSA –B339, Cylinders, Spheres and Tubes for Transportation of Dangerous Goods and Commission .
- The LP gas tank must have a shutoff valve terminating in an LP valve outlet that is compatible with a Type 1. LP gas supply cylinder must have a shut off valve terminating in a valve outlet specified for connection type QCC1 in the standard for compressed gas cylinder valve outlet and inlet connection ANSI/CGA-V-1 as applicable. LP gas supply cylinder must be fitted with an Overfill Protection Device (O.P.D) The LP gas tank must also have a safety relief device that has a direct connection with the vapor space of the tank.
- The tank supply system must be arranged for vapor withdrawal.
- The LP gas tank used must have a collar to protect the tank valve
- Place dust cap on cylinder valve outlet whenever the cylinder is not in use. Only install the type of dust cap on the cylinder valve outlet that is provided with the cylinder valve. Other types of cap or plugs may result in leakage of propane
- **Never** connect an unregulated LP gas tank to your gas grill.
- This outdoor cooking gas appliance is equipped with a high capacity hose/regulator assembly for connection to a standard 20lb. Liquid propane cylinder.
- Have your LP gas tank filled by a reputable propane gas dealer and visually inspected and re-qualified at each filling.
- Do not store a spare LP gas cylinder under or near this appliance.
- Never fill the cylinder beyond 80 percent full .
 - If the information is not followed exactly, a fire resulting in death or serious injury could occur.
- Always keep LP gas tanks in an upright position.
- Do not store or use gasoline or other flammable vapors and liquids in the vicinity of this or any other appliance.
- Storage of an outdoor cooking gas appliance indoors is permissible only if the cylinder is disconnected and removed from the outdoor cooking gas appliance..
- When your gas grill is not in use the gas must be turned off at LP gas tank.
- The gas must be turned off at the supply cylinder when the outdoor cooking gas appliance is not in use.
- LP gas tank must be stored outdoors in a well-ventilated area and out of reach of children. Disconnected LP gas tanks must not be stored in a building. Garage or any other enclosed area.

PROPER PLACEMENT AND CLEARANCE OF GRILL

- Never use your gas grill in a garage, porch, shed, breezeway or any other enclosed area. Your gas grill is to be used outdoors only.
- Do Not install this unit into combustible enclosures.
- Minimum clearance from sides and back of unit to combustible construction, 24 inches (61cm) from sides and 24 inches (61cm) from back.
- **DO NOT** use this appliance under overhead combustible surfaces. This outdoors cooking gas appliance is not intend to be install in or on recreational vehicles and/or boats.
- Do Not obstruct the flow of ventilation air around the gas grill housing. Only use the regulator and the hose assembly supplied with your gas grill. Replacement regulators and hose assemblies must be those specified in this manual.
- The regulator and hose assembly must be inspected before each use of the grill. If there is excessive abrasion or wear or if the hose is cut, it must be replaced prior to the grill being put into operation. The replacement hose assembly shall be that specified by the manufacturer.
- Pressure regulator and hose assembly supplied with the outdoor cooking gas appliance must be used. Never substitute other types of regulator. Contact customer service for manufacturer specified replacement parts.
- This outdoor cooking gas appliance is equipped with a pressure regulator comply with the standard for Pressure Regulating Valves for LP Gas ANSI/ UL 144.
- Do not use briquettes of any kind in the grill.
- The grill is designed for optimum performance without the use of briquettes. Do not place briquettes on the radiant as this will block off the area for the grill burners to vent. Adding briquettes can damage ignition components and knobs, and void the warranty.
- Keep the back and side cart free and clear from debris. Keep any electrical supply cord, or the rotisserie motor cord away from the heated areas of the grill.
- Never use the grill in extremely windy conditions. If located in a consistently windy area (oceanfront, mountaintop, etc.) a windbreak will be required. Always adhere to the specified clearance.
- Never use a dented or rusty propane tank.
- Keep any electrical supply cord and the fuel supply hose away from any heated surface
- While lighting, keep your face and hands as far away from the grill as possible.
- Burner adjustment should only be performed after the burner have cooled.



WARNING

Your grill will get very hot. Never lean over the cooking area while using your grill. Do not touch cooking surfaces, grill housing, lid or any other grill hot surface while the grill is in operation, or until the gas grill has cooled down after use.

Failure to comply with these instructions may result in serious bodily injury.

ROTISSERIE DRIVE MOTOR

USE ONLY FOR OUTDOORS, DO NOT EXPOSE TO RAIN.

CAUTION: TO ENSURE CONTINUED PROTECTION AGAINST RISK OF ELECTRIC SHOCK, CONNECT TO PROPERLY GROUNDED OUTLETS ONLY, TO REDUCE THE RISK OF ELECTRIC SHOCK, KEEP EXTENSION CORD CONNECTION DRY AND OFF THE GROUND.

INSECT WARNING:

Spiders and insects can nest in the burners of this and any other grill, and cause the gas to flow improperly. This is a very dangerous condition, which can cause a fire to occur behind and beneath the valve panel, thereby damaging the grill and making it unsafe to operate. Inspect the grill twice a year.



WARNING

Keep a spray bottle of soapy water near the gas supply valve and check the connections before each use.

DO NOT USE ALUMINUM FOIL TO LINE THE GRILL RACKS OR GRILL BOTTOM.

This can severely upset combustion airflow or trap excessive heat in the control area.

DO NOT LEAVE THE GRILL UNATTENDED WHILE COOKING.

SAFETY PRACTICES TO AVOID PERSONAL

INJURY

When properly cared for, your grill will provide safe, reliable service for many years. However, extreme care must be used as the grill produces intense heat that can increase accident potential. When using this appliance basic safety practices must be followed, including the following:

Do not repair or replace any part of the grill unless specifically recommended in this manual. All other service should be referred to a qualified technician.

This grill is not intended to be installed in or on recreational vehicles or boats

Children should not be left alone or unattended in an area where the grill is being used. Do not allow them to sit, stand or play in or around the grill at any time.

Do not store items of interest to children around or below the grill.

Do not permit clothing, pot holders or other flammable materials to come in contact with or too close to any grate, burner or hot surface until it has cooled. The fabric could ignite and cause

personal injury.

For personal safety, wear proper apparel. Loose fitting garments or sleeves should never be worn while using this appliance. Some synthetic fabrics are highly flammable and should not be worn while cooking.

Only certain types of glass, heat-proof glass ceramic, earthenware, or other glazed utensils are suitable for grill use. These materials may break with sudden temperature changes. Use only on low or medium heat settings in accordance with the manufacturer's guidelines.

Do not heat unopened food containers. A build-up of pressure may cause the containers to burst.

Use a covered hand when opening the grill lid.

Never lean over an open grill.

When lighting a burner, pay close attention to what you are doing. Make certain you are aware of which burner you are lighting, so your body and clothing remain clear of open flames.

When using the grill, do not touch the grill rack, burner grate or immediate surroundings as these areas become extremely hot and could cause burns. Use only dry potholders. Moist or damp potholders on hot surfaces may cause steam burns. Do not use a towel or bulky cloth in place of potholders. Do not allow potholders to touch hot portions of the grill rack.

Grease is flammable. Let hot grease cool before attempting to handle it. Do not allow grease deposits to collect in the grease tray at the bottom of the grill's firebox. Clean the grease tray often.

Do not use aluminum foil to line the grill racks or grill bottom. This can severely upset combustion air flow or trap excessive heat in the control area.

For proper lighting and performance of the burners keep the burner ports clean. It is necessary to clean them periodically for optimum performance. The burners will only operate in one position and must be mounted correctly for safe operation.

Clean the grill with caution. To avoid steam burns, do not use a wet sponge or cloth to clean the grill while it is hot. Some cleaners produce toxic fumes or can ignite if applied to a hot surface.

Turn off grill controls and make certain the grill is cool before using any type of aerosol cleaner on or around the grill. The chemical that produces the spraying action could, in the presence of heat, ignite or cause metal parts to corrode.

Do not use the grill to cook excessively fatty meats or other products which promote flare – ups.

Do not operate the grill under unprotected combustible constructions. Use only in well ventilated areas. Do not use in buildings, garages, sheds, breezeways or other such enclosed areas.

Keep the area surrounding the grill free from combustible materials including, fluids, trash, and vapors such as gasoline or charcoal lighter fluid. Do not obstruct the flow of combustion and ventilation air.



WARNING

This outdoor cooking gas appliance is not intended to be installed in or on boats. For other than RV grills, a statement that this appliance is not intended to be installed in or on recreational vehicles.

Assemble the shelf to the left side panel and the side burner to the right side panel respectively with 4pcs $\frac{1}{4}$ "*10 screws, as the figure show below

Attention: the side shelf and side burner should be similarly screwed:

- a. The upper 2 screws should be screwed from inside to outside
- b. The lower 2 screws should be screwed from outside to inside.

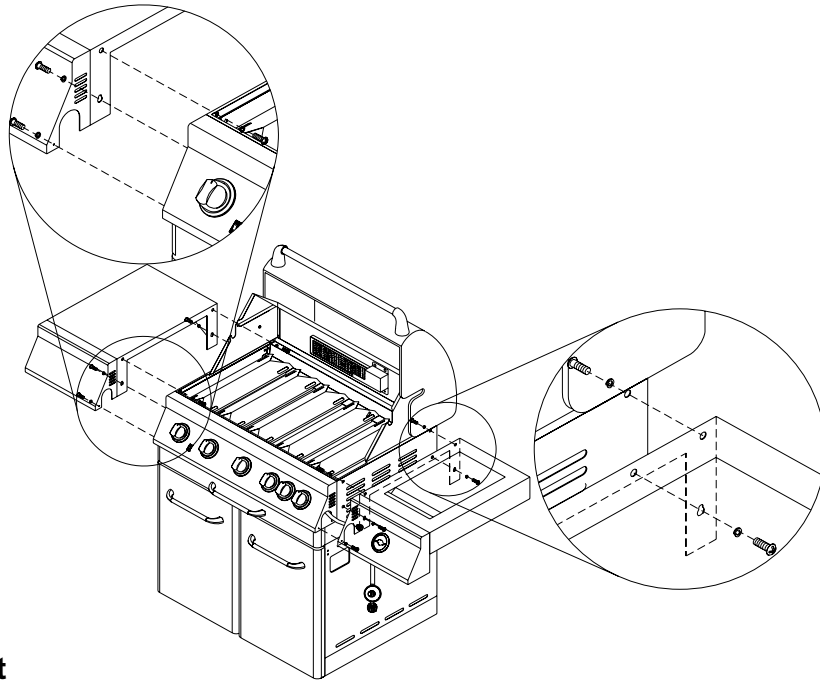

Assemble mini bracket

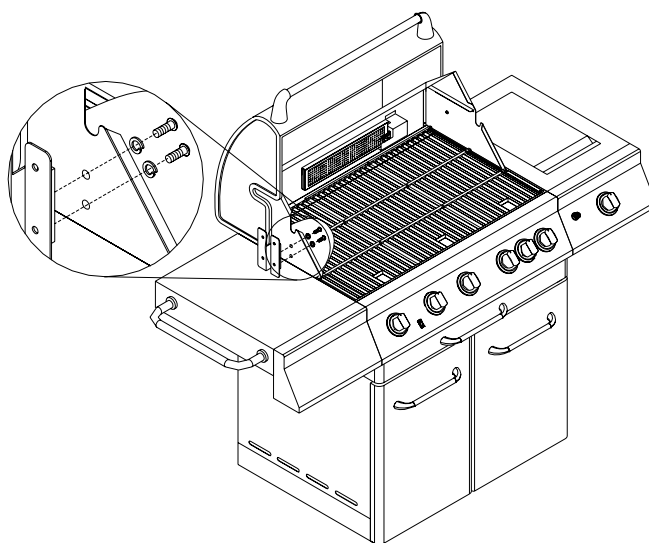

Assemble the side burner valve to the side burner control panel as the figure shown below.

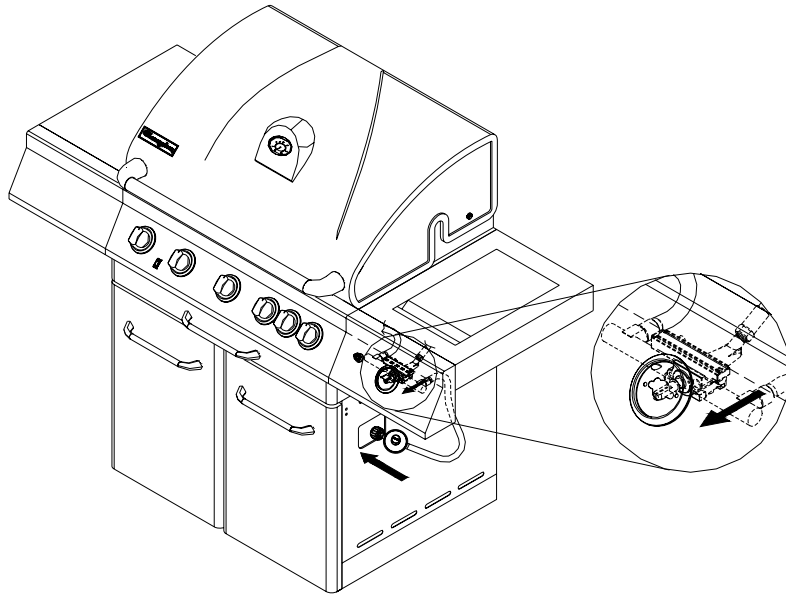

Assemble the side burner knob to the side burner control panel as the figure shown below.

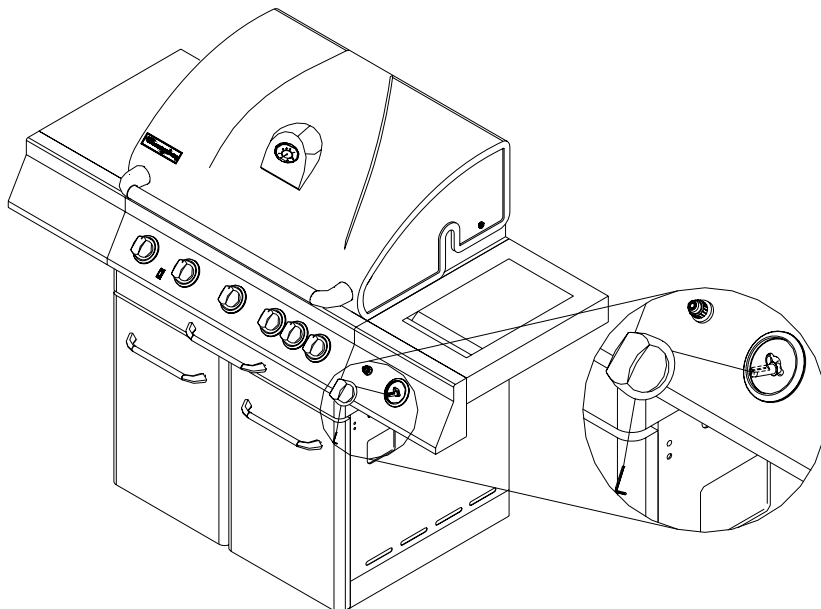

In order to install the battery, remove the ignition button housing. Please keep the positive pole of the battery facing toward you. Insert the battery into the housing. Replace the ignition button on the housing after the battery is installed.

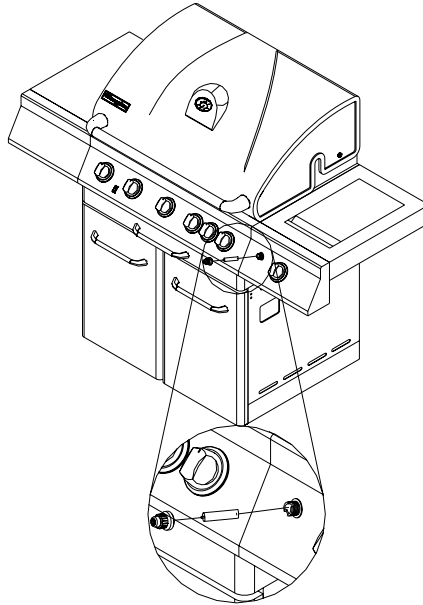

Assemble the side shelf handle to the side shelf with 2 pcs $\frac{1}{4}$ *10 screws as the figure show below.

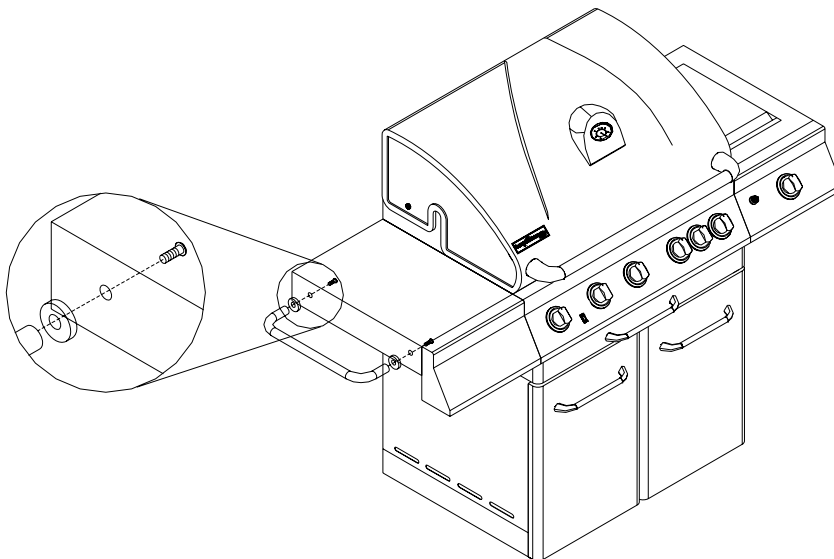

Attach propane gas tank to regulator inlet fitting by turning the regulator clockwise as shown in figure below. LP gas cylinder must be fitted with a listed overfill prevention device (OPD). Secure liquid propane gas cylinder to the slide out tray using the gas cylinder retention screw.

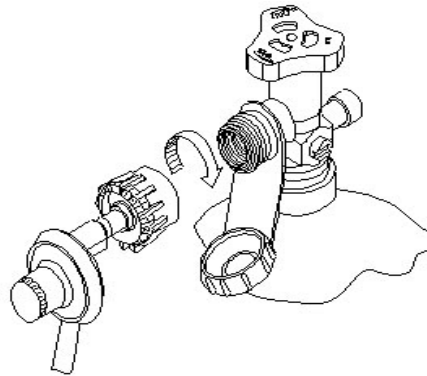

1. Put the gas tank into the gas tank tray. Then tighten the gas tank retention kit for securing the gas tank as shown in the figure 1 below.
2. Here are two buttons “A” and “B” on gas tank tray, the button “A” is used to secure the gas tank tray, if you want to pull out the gas tank tray, please press button “B” .

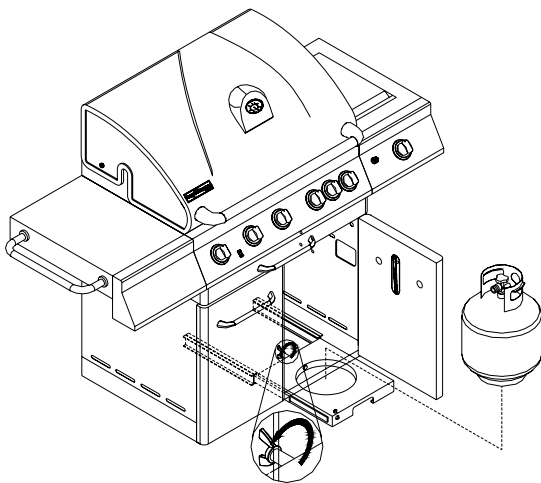

Figure 1

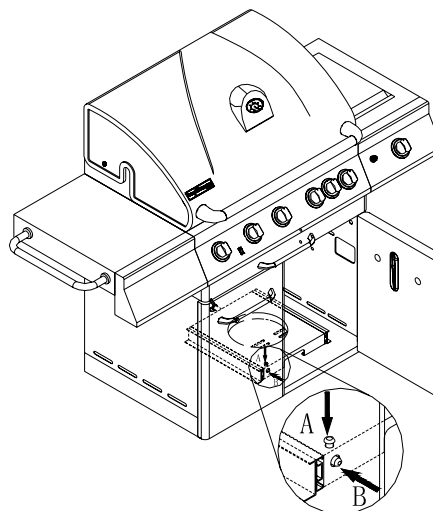
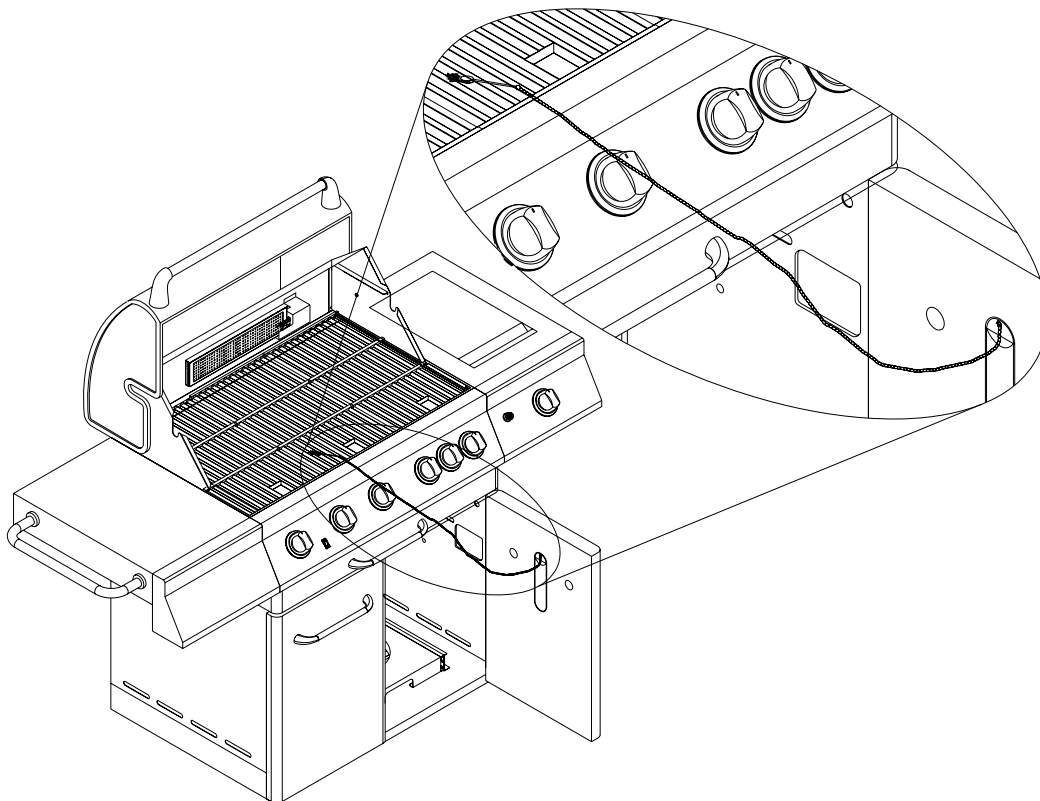

Figure 2

To Match Light the Grill

1. If the burner will not light after several attempts then the burner can be match lit.
2. If you have attempted to light the main burners with the igniter, allow 5 minutes for any accumulated gas to dissipate.
3. Insert a match into the lighting rod. Ignite the match and insert through the cooking grid to the burner.
4. Press the control knob and rotate it to the “Ignite/HI” setting. The burner should light immediately.
5. If the burner does not light within seconds turn the knob to the “OFF” position, wait 5 minutes and try again. (as shown below)



NEVER CONNECT AN UNREGULATED GAS SUPPLY LINE TO THE APPLIANCE. USE THE REGULATOR/HOSE ASSEMBLY SUPPLIED.

This is a liquid propane configured grill. Do not attempt to use a natural gas supply unless the grill has been reconfigured for natural gas use.

Total gas consumption (per hour) of this stainless steel gas grill with all burners on "HI":

Main burner	50,000 Btu/hr.
Rear burner	10,000 Btu/hr.
Sear burner	15,000 Btu/hr.
Total	75,000 Btu/hr.

L.P. TANK REQUIREMENT

A dented or rusty L.P. tank may be hazardous and should be checked by your L.P. supplier. Never use a cylinder with a damaged valve. The L.P. gas cylinder must be constructed and marked in accordance with the specifications for L.P. gas cylinders of the U.S. Department of Transportation (DOT) or the National Standard of Canada, CAN/CSA-B339, Cylinders, Spheres and Tubes for Transportation of Dangerous Goods; and Commission, as applicable. Overfilling prevention device (OPD) shall be provided on cylinder & QCCI connection on the cylinder valve, ANSI/CGA-V-1. The cylinder supply system must be arranged for vapor withdrawal. The cylinder must include a collar to protect the cylinder valve. The cylinder must be provided with a shut off valve terminating in an L.P. gas supply cylinder valve outlet specified, as applicable, for connection type

QCC1 in the standard for compressed gas cylinder valve outlet and inlet connection ANSI/CGA-V-1.

Manifold pressure: 11”(27.94cm) water column (W.C.).

L.P. GAS HOOK-UP

Ensure that the black plastic grommets on the LP cylinder valve are in place and that the hose does not come into contact with the grease tray or the grill head.

CONNECTION

Your stainless steel grill is equipped with gas supply orifices for use only with liquid propane gas. It is also equipped with a high capacity hose/regulator assembly for connection to a standard 20lb. L.P. cylinder (18-1/4” (46.35cm) high, 12-1/4”(31cm) diameter). To connect the L.P. gas supply cylinder, please follow the steps below:

1. Make sure tank valve is in its full off position (turn clockwise to stop)
2. Check tank valve to assure it has proper external male threads (type 1 connection per ANSIZ21.81)



3. Make sure all burner valves are in their off position.
4. Inspect valve connections, port, and regulator assembly. Look for any damage or debris. Remove any debris. Inspect hose for damage. Never attempt to use damaged or obstructed equipment. See your local L.P. gas dealer for repair.

- When connecting regulator assembly to the valve, hand tighten the quick coupling nut clockwise to a complete stop. Do not use a wrench to tighten. Use of a wrench may damage the quick coupling nut and result in a hazardous condition.
- Open the tank valve fully (counterclockwise). Apply the soap solution with a clean brush to all gas connections. See below. If growing bubbles appear in the solution the connections are not properly sealed. Check each fitting and tighten or repair as necessary.
- If you have a gas connection leak you cannot repair, turn gas OFF at supply tank, disconnect fuel line from your grill and call 1-800-913-8999 or your gas supplier for repair assistance.
- Also apply soapy solution to the tank seams. See below. If growing bubbles appear, shut tank OFF and do not use or move it! Contact an LP gas supplier or your fire department for assistance

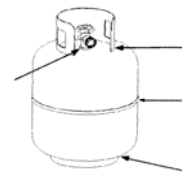

To disconnect L.P. gas cylinder:

- Turn the burner valves off.
- Turn the tank valve off fully (turn clockwise to stop).
- Detach the regulator assembly from the tank valve by turning the quick coupling nut counterclockwise.

Installer Final Check List

- ✓ Specified clearance maintained 24”(61cm) from combustibles.
- ✓ All internal packaging removed.
- ✓ Knobs turn freely.
- ✓ Burners are tight and sitting properly on orifices.
- ✓ Pressure regulator connected and set. Gas connections to grill using hose & regulator assembly provided (pre-set for 11.0” water column).
- ✓ Unit tested and free of leaks.
- ✓ User informed of gas supply shut off valve location

PROPANE CYLINDER CAUTIONS

- Do Not store a spare LP-gas cylinder under or near this appliance.
- NEVER fill the cylinder beyond 80 percent full.
- If the information in “a” and “b” is not followed exactly, a fire causing death or serious injury may occur.

USER, PLEASE RETAIN THIS MANUAL FOR FUTURE REFERENCE.

GENERAL

Although all gas connections on the grill are leak tested at the factory prior to shipment, a complete gas tightness check must be performed at the installation site due to possible mishandling in shipment, or excessive pressure unknowingly being applied to the unit. Periodically check the whole system for leaks following the procedures listed below. If the smell of gas is detected at anytime you should immediately check the entire system for leaks.

BEFORE TESTING

Make sure that all packing material is removed from the grill including the burner tie-down straps.

DO NOT SMOKE WHILE LEAK TESTING.

NEVER PERFORM LEAK TEST WITH AN OPEN FLAME.

Make a soap solution of one part liquid detergent and one part water. You will need a spray bottle, brush, or rag to apply the solution to the fittings. For the initial leak test, make sure the L.P. cylinder is full.

TO TEST

1. Make sure the control valves are in the "OFF" position, and turn on the gas supply.
2. Check all connections from the LP gas regulator and supply valve up to and including the connection to the manifold pipe assembly (the pipe that goes to the burners). Soap bubbles will appear where a leak is present.
3. If a leak is present, immediately turn off the gas supply and tighten the leaky fittings.
4. Turn the gas back on and recheck.
5. Should the gas continue to leak from any of the fittings, turn off the gas supply and contact customer service at 1-800-913-8999.



Only those parts recommended by the manufacturer should be used on the grill.

Substitution will void the warranty. Do not use the grill until all connections have been checked and do not leak.

GAS FLOW CHECK

Each grill burner is tested and adjusted at the factory prior to shipment; however, variations in the local gas supply may make it necessary to adjust the burners. The flames of the burners should be visually checked.

Flames should be blue and stable with no yellow tips, excessive noise or lifting. If any of these conditions exist, check to see if the air shutter or burner ports are blocked by dirt, debris, spider webs, etc. If you have any questions regarding flame stability, please call customer service 1-800-913-8999.

ALWAYS CHECK FOR LEAKS AFTER EVERY L.P. TANK CHANGE

Check all gas supply fittings for leaks before each use. It is handy to keep a spray bottle of soapy water near the shut-off valve of the gas supply line. Spray all the fittings. Bubbles indicate leaks.

CAUTIONS

Place dust cap on cylinder valve outlet when the cylinder is not in use. Only install the type of dust cap on the cylinder valve outlet that is provided with the cylinder valve. Other types of caps or plugs may result in leakage of propane.

The gas must be turned off at the supply cylinder when the unit is not in use.

If the appliance is stored indoors the cylinder must be disconnected and removed from the appliance. Cylinders must be stored outdoors in a well-ventilated area out of the reach of children.



Your grill is ready to use!

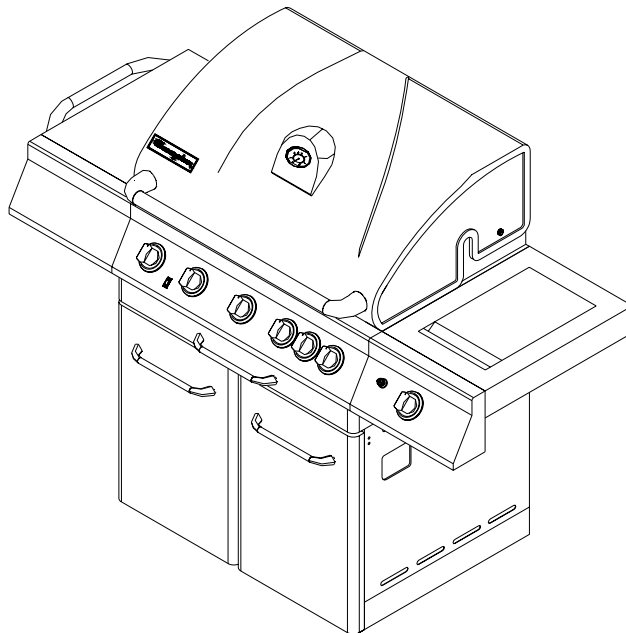

GENERAL USE OF THE GRILL AND ROTISSERIE

Each main burner is rated at 10,000 Btu/hr. The main grill burners encompass the entire cooking area and are side ported to minimize blockage from falling grease and debris. Above the burners are porcelain coated steel radiant (flame tamer). The igniter knobs are located on the lower center portion of the valve panel. Each rotary igniter is labeled on the control panel.

USING THE GRILL

Grilling requires high heat for searing and proper browning. Most foods are cooked at the "HI" heat setting for the entire cooking time. However, when grilling large pieces of meat or poultry, it may be necessary to turn the heat to the lower setting after the initial browning. This cooks the food through without burning the outside. Foods cooked for a long time or foods basted with a sugary marinade may need the lower heat setting near the end of the cooking time.

NOTE: This stainless steel grill is designed to grill efficiently without the use of lava rocks or briquettes of any kind. Heat is radiated by the stainless steel flame tamers positioned above each burner.

NOTE: The hot grill sears the food, sealing in the juices. The longer the preheat, the faster the meat browns and the darker the grill marks.

WARNING: IMPORTANT!

USING THE SIDE BURNER:

Inspect the gas supply hose prior to turning the gas "ON". If there is evidence of cuts, wear or abrasion, it must be replaced prior to use. Do not use the side burner if the odor of gas is present.

USING ROTISSERIE BURNER

Your grill is capable of performing back burner rotisserie cooking. Light the rear burner as described in the lighting instructions, see page 20. Once lit, the rotisserie burner will reach cooking temperatures in about 1 minute.

DO NOT LEAVE THE GRILL UNATTENDED WHILE COOKING.

CAUTION: PLEASE TAKE OFF THE WARMING RACK WHEN USING THE ROTISSERIE BURNER. THE HIGH HEAT COMING FROM THE ROTISSERIE BURNER MAY CAUSE THE WARMING RACK TO BEND.

Grill Lighting Instructions

WARNING: IMPORTANT!

BEFORE LIGHTING...

Inspect the gas supply hose prior to turning the gas "ON". If there is evidence of cuts, wear, or abrasion, it must be replaced prior to use. Do not use the grill if the odor of gas is present. Only the pressure regulator and hose assembly supplied with the unit should be used.

Never substitute regulators and hose assembly for those supplied with the grill. If a replacement is necessary, contact the **manufacturer** for proper replacement. The replacement must be that specified in the manual.

Screw the regulator (type QCC1) onto the tank. Leak check the hose and regulator connections with a soap and water solution before operating the grill.

TO LIGHT THE GRILL BURNER:

Make sure all knobs are "OFF" then turn on the gas supply from the LP tank. Always keep your face and body as far from the grill as possible when lighting.

Your stainless steel grill has an exclusive patented built-in ignition. The igniter is built in to the valve. To ignite each burner simply push and turn the control knobs to the HI setting, you will hear the valve click as it sends a spark to the pilot flame. If the burner does not light wait 5 minutes for any excess gas to dissipate and then retry.

WARNING: Always keep your face and body as far away from the burner as possible when lighting.

TO LIGHT THE SIDE BURNER

To light the side burner, remove any cooking utensils from the burner grate. Push and turn the control knob counterclockwise to the "IGNITE/HI" position. If the burner does not light, turn the control

knob to "OFF". If the smell of gas is detected and the igniter is not functioning, immediately turn the control knob "OFF". Allow 5 minutes for any accumulated gas to dissipate. If the side burner igniter is not functioning, see the following section for match lighting.

TO MATCH LIGHT THE GRILL

If the burner will not light after several attempts then the burner can be match lit.

1. Locate match light extension rod
2. Use this device to match light your burners

Simply place a lighted match between the coils on the end of the extension rod and hold next to the burner to ignite.

If you've just attempted to light the burner with the igniter, allow 5 minutes for any accumulated gas to dissipate. Keep your face and hands as far away from the grill as possible. Insert a lit match attached to lighting rod or lighter through the cooking grids to the burner.(see next page) Press the control knob and rotate left to the IGNITE/HI setting, continue to press the knob until the burner ignites. Burner should light immediately. If the burner does not light in 4 seconds turn the knob off, wait 5 minutes and try again.

TO MATCH LIGHT THE SIDE BURNER

Hold a lit extended match or lighter near the side burner ports, turn the control knob counterclockwise to "IGNITE/HI". Move your hand immediately once the burner is lit. Rotate the control knob to the desired setting.

Keep a spray bottle of soapy water near the gas supply valve and check the connections before each use.

Do not attempt to light the grill if odor of gas is present. Call for service

1-800-913-8999

FLAME CHARACTERISTICS

Check for proper burner flame characteristics.

Burner flames should be blue and stable with no yellow tips, excessive noise, or lifting. If any of these conditions exist call our customer service line. If the flame is yellow, it indicates insufficient air. If the flame is noisy

And tends to lift away from the burner, it

Indicates too much air.

Each burner is adjusted prior to shipment; however, variations in the local gas supply may take minor adjustments as necessary.

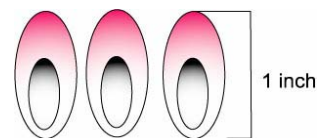
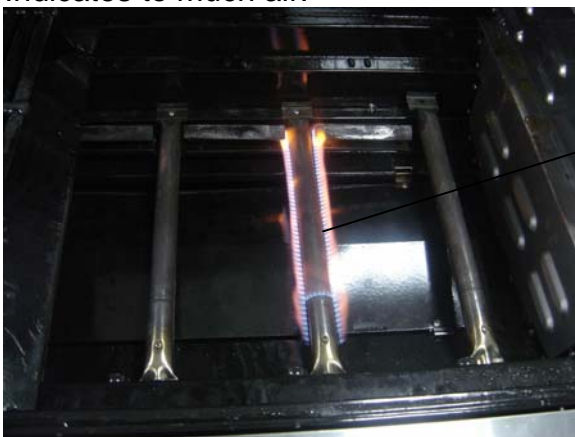

Visually check the burner flames prior to each use, The flames should look like this picture, if they do not, refer to the burner maintenance part of this manual

Main burner lighting illustration



Step 1: Make sure the lid is open



Step 2: Push and turn the Main Burner knob slowly to IGNITE/HI. Burner should light immediately. Adjust knob as desired after burner is lit.

Step 3: If burner does not light up, turn the knob to OFF and repeat lighting procedure. If burner does not light up after step 2, turn the knob to OFF, wait 5 minutes, and repeat lighting procedure or light by match

Rear burner & Searing side burner lighting illustration



Step 1: Push and turn Rear Burner or Sear Burner Knob slowly to IGNITE/ON. At the same time, press the electronic ignition button to light the burner. Once it is lit, release electronic ignition button, and Hold the Rear Burner or Sear Burner knob for another 15 seconds to be sure the burner stays lit.



Step 2: Release the electronic ignition button and knob.



Step 3: If ignition does not occur in 5 seconds, turn the knob (s) to OFF, wait 5 minutes and repeat the lighting procedure or light by match.

- **TO USE MOTOR SAFELY, PLEASE READ WARNING BEFORE PRIOR TO USE**

ROTISSERIE DRIVE MOTOR

USE ONLY FOR OUTDOORS, DO NOT EXPOSE TO RAIN.

⚠ CAUTION: TO ENSURE CONTINUED PROTECTION AGAINST RISK OF ELECTRIC SHOCK, CONNECT TO PROPERLY GROUNDED OUTLETS ONLY, TO REDUCE THE RISK OF ELECTRIC SHOCK, KEEP EXTENSION CORD CONNECTION DRY AND OFF THE GROUND.

⚠ WARNING

ELECTRICAL GROUNDING INSTRUCTIONS This appliance (rotisserie motor) is equipped with a plug and should be plugged directly into a properly grounded receptacle. **DO NOT** cut or remove the grounding prong from this plug.

Keep the rotisserie motor electric cord away from the heated surfaces of the grill. When not in use remove and store the motor in a dry location.

This motor is with 120V AC & 60Hz, 4W, 40mA, If exceed the voltage, motor will be burnt out.

Rotisserie Operating illustrations:

1. Place rotisserie motor onto the motor bracket, plug into a properly grounded outlet. Ensure that the rotisserie spit rod is inserted into the motor prior to turning on the motor.



Insert rotisserie spit rod



120V AC 60Hz, 4W,
40mA



2. When finished using rotisserie motor, switch to "off position and unplug



STAINLESS STEEL

The grill is made from non-rusting and 430 stainless steel. There are many different stainless steel cleaners available. Always use the mildest cleaning procedure first, scrubbing in the direction of the grain. To touch up noticeable scratches in the stainless steel, sand very lightly with dry 100 grit emery paper in the direction of the grain. Specks of grease can gather on the surfaces of the stainless steel and bake on to the surface and give the appearance of rust. For removal use an abrasive pad in conjunction with a stainless steel cleaner.

GRILL RACK The easiest way to clean the grill is immediately after cooking is completed and after turning off the flame. Wear a barbecue mitt to protect your hand from the heat and steam. Dip a brass bristle barbecue brush in tap water and scrub the hot grill. Dip the brush frequently in the bowl of water. Steam, created as water contacts the hot grill, assists the cleaning process by softening any food particles. The food particles will fall and burn. If the grill is allowed to cool before cleaning, cleaning will be more difficult.

ENSURE THAT THE GAS SUPPLY AND THE KNOBS ARE IN THE "OFF" POSITION. MAKE SURE THE BURNERS ARE COOL BEFORE REMOVAL.

GRILL BURNERS

Extreme care should be taken when replacing a burner as it must be correctly centered on the orifice before any attempt is made to relight the grill. Frequency of cleaning will depend on how often you use the grill.

MAIN GRILL BURNER CLEANING

Ensure the gas supply is off and the knobs are in the "OFF" position. Make sure the grill is cool. Clean the exterior of the burner with a wire brush. Clear stubborn scale with a metal scraper. Clear any clogged ports with a straightened paper clip. Never use a wooden toothpick as it may break off and clog the port. Please note if insects or other obstructions are blocking the flow of gas through the burner, and if so you will need to call our customer service line 1-800-913-8999.

GREASE TRAY CLEANING:

The grease tray should be emptied and wiped down periodically and washing with a mild detergent and warm water solution. A small amount of sand or cat litter may be placed in bottom of grease tray to absorb the grease. Check the grease tray frequently, don't allow excess grease to accumulate and overflow out of the grease tray.

BURNER CLEANING:

1. Turn off the gas supply, and make sure all the knobs are in the "OFF" position.
2. Wait for the grill to cool.
3. Clean the exterior of the burner with a wire brush. Use a metal scraper for stubborn stains.
4. Clear clogged port with a straightened paper clip. Never use a wooden toothpick as it may break off and clog the port
5. If insects or other obstructions are blocking the flow of gas through the burner, call customer service at 1-800-913-8999

Make sure to place the burner onto the orifice.

OVEN RACKS:

Clean stainless steel oven racks with solution of detergent and hot water. To clean heavy soil, use a scouring pad such as steel wool with plenty of water.

HOW TO REPLACE MAIN BURNER

Step 1. Insert the burner onto the orifice.



Step 2. Secure the main burner on the back wall of fire box with 1 screw.

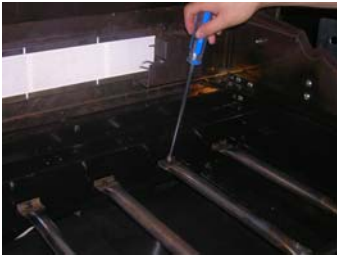

STAINLESS STEEL :

There are many different stainless steel cleaners available. Always use the mildest cleaning procedure first, scrubbing in the direction of the grain. Do not use steel wool as it will scratch the surface. To touch up noticeable scratches in the stainless steel, sand very lightly with dry 100 grit emery paper in the direction of the grain.

BURNER GRATE:

The top burner grate is porcelain coated cast iron. To avoid burns do not clean a hot grate. They may be wiped while in place with hot, soapy water, rinsed and wiped dry. Never immerse a hot grate in water.

CAUTION:

1. Keep outdoor cooking gas appliance area clear and free from combustible materials, gasoline and other flammable vapors and liquids.
2. Do not obstruct the flow of combustible and ventilation air.
3. Keep the ventilation openings of the cylinder enclosure free and clear from debris.

SPIDER AND INSECT WARNING!!!

Checking and cleaning burner/ venturi tubes for insects and insect nests. A clogged tube can lead to a fire beneath the grill.

Spiders and small insects occasionally spin webs or make nests in the grill burner tubes during transit and warehousing. These webs can lead to gas flow obstruction which could result in a fire in and around burner tubes. This type of fire is known as "FLASH-BACK" and can cause serious damage to your grill and create an unsafe operating condition for the user.

Although an obstructed burner tube is not the only cause of "FLASH-BACK", it is the most common cause.

To reduce the chance of "FLASH-BACK", you must clean the burner tubes before assembling your grill, and at least once a month in late summer or early fall when spiders are most active. Also perform this burner tube cleaning procedure if your grill has not been used for an extended period of time.

WHEN TO LOOK FOR SPIDERS

You should inspect the burners at least once a year or immediately after any of the following conditions occur:

1. The smell of gas in conjunction with the burner flames appearing yellow.
2. The grill does not reach temperature.
3. The grill heats unevenly.
4. The burners make popping noises.

BEFORE CALLING FOR SERVICE

If the grill does not function properly, use the following check list before contacting your customer service. You may save the cost of a service call. "Please check page 46"

PREHEATING: The grill lid should be in a closed position during the preheat time period. It is necessary to preheat the grill for a short time before cooking certain foods, depending on the type of food and the cooking temperature. Food that requires a high cooking temperature needs a pre-heat period of five minutes; food that requires a lower cooking temperature needs only a period of two to three minutes. There is no need to preheat for casseroles or other foods that require slow cooking.

COOKING TEMPERATURES

High setting-Use this setting for fast warm-up, for searing steaks and chops, and grilling.

Low setting-Use this setting for all roasting, baking, and when cooking very lean cuts such as fish.

These temperatures vary with the outside temperature and the amount of wind.

Cooking with in-direct Heat: You can cook poultry and large cuts of meat slowly to perfection on one side of the grill by indirect heat from the burner on the other side. Heat from the lighted burner circulates gently throughout the grill, cooking the meat or poultry without any direct flame touching it. This method greatly reduces flare-ups when cooking extra fatty cuts, because there is no direct flame to light the fats and juices that drip down during cooking. Prior to lighting the grill place a drip pan slightly smaller than the cut of meat on the flame tamer surface under the meat being cooked. This will allow you to catch meat juices for making gravy.

Flare-Ups: The fats and juices that drip from the meat cause flare-ups. Since flare-ups impart the distinctive taste and color for food cooked over an open flame, they should be expected and encouraged within reason.

Nevertheless, uncontrolled flaring can result in a ruined meal.

CAUTION: If burners go out during operation, close gas supply at source, and turn all gas valves off. Open lid and wait five minutes before attempting to re-light (this allows accumulated gas fumes to clear).

CAUTION: Should a grease fire occur, close gas supply at source, turn off all burners and leave lid closed until fire is out.

CAUTION: DO not attempt to disconnect any gas fitting while your grill is in operation. As with all appliances, proper care and maintenance will keep them in top operating condition and prolong their life. Your gas grill is no exception.

PROBLEM	SOLUTION
<p>When attempting to light my grill, it will not light immediately.</p>	<ul style="list-style-type: none"> • Make sure you have a spark while you are trying to light the burner (if no spark) • Ensure that the wire is connected to the electrode assembly. • Clean wire (s) and / or electrode with rubbing alcohol and a clean swab. Wipe with a clean cloth. • Check to see if the other burners operate. If so. Check the gas orifice on the malfunctioning burner for an obstruction.
<p>Rotisserie burner will not light when the igniter button is pushed.</p>	<ul style="list-style-type: none"> • Check to see if debris is blocking the electrode. • Check to see if there is a spark that jumps to the burner from the electrode. If no spark is seen, check the battery located inside the igniter button. To open turn counter clockwise. Remove. It was combined with #2 Is OK. • Gently bend the electrode closer to the burner until a spark is seen to jump from the electrode to the burner when you push the igniter button. • Does the infrared back burner light when attempting to light with a match ? If not, check to ensure the gas is on.
<p>Regulator makes noise.</p>	<ul style="list-style-type: none"> • Vent hose on the regulator may be plugged or regulator may be faulty. • Ensure the vent hole on the regulator is not obstructed. Clear the hole, close the gas control valves. Wait ten minutes and re-start. • Check your flames for proper performance if the flames are not correct replace regulator.
<p>Full size cover does not fit the grill.</p>	<ul style="list-style-type: none"> • Cover may be incorrect for your grill. It may be a tight fit. Ensure the cover is the correct length for your grill. Measure it left to right. Compare to the grill's measurement. • Compare the location and size of the hood portion of the cover to your grill. • Spread the cover and allow it to relax, preferably in warm sunlight or in a warm room. • For grill with a side shelf bunch the cover like a sock, put on left to right.

<p>Rotisserie motor will not turn</p>	<ul style="list-style-type: none"> • Ensure the motor is connected to a properly grounded power supply. • Ensure the on / off switch is in the on position. • Ensure that the spit is fully inserted into the rotisserie motor • Ensure that the load does not exceed the 40 pound operational capacity. • Ensure that there is no encumbrance or drag.
<p>Grill only heats to 200-300 degrees.</p>	<ul style="list-style-type: none"> • Check to see if the fuel hose is bent or kinked. • Make sure the grill area is clear of dust. • Make sure the burner and orifices are clean. • Check for spiders and insects. • The regulator has a safety device that restricts the flow of gas in the event of a leak. This safety device can be triggered without a gas leak. To reset the safety device, turn off all burners and close the LP tank valve. Disconnect the regulator from the LP tank and wait one minute. Reconnect the regulator to the LP tank and slowly open the LP tank valve until the valve is fully open. Light all burners and observe the temperature.
<p>Grill takes a long time to preheat.</p>	<ul style="list-style-type: none"> • Normal preheat 500-600degrees, takes about 10-15 min. Cold weather and wind may effect your preheat time. • If you are using volcanic rock or briquettes they can increase the preheat time and maximum temperature.
<p>Burner flames are not light blue.</p>	<p>--Too much or not mixture air mixture for the flame. --Elevation is the principal cause, however cold weather can affect the mixture. Burner adjustment may be required. --Grill is in a windy location.</p>

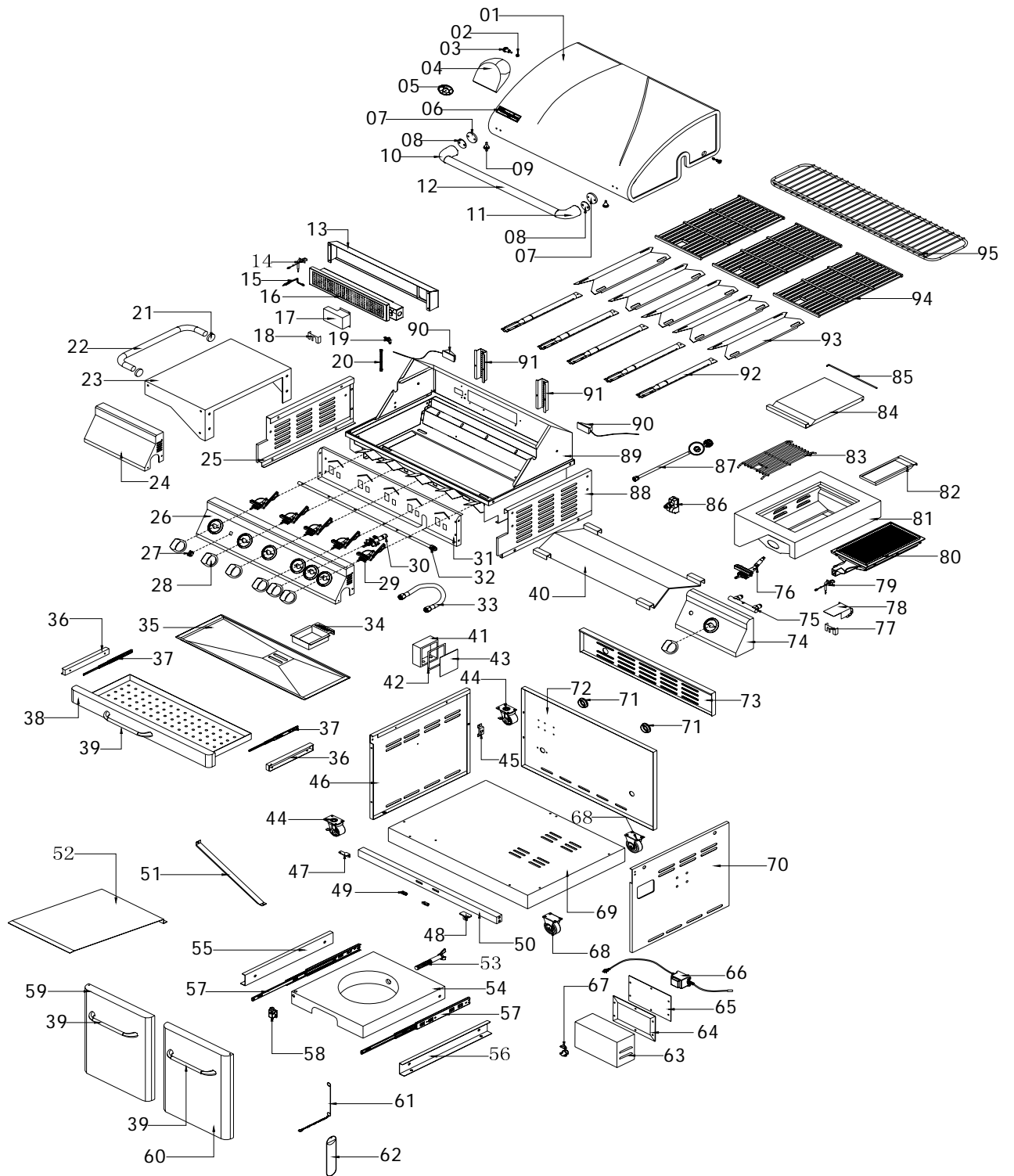

REF #	DESCRIPTION	QTY	REF #	DESCRIPTION	QTY
1	Main Lid	2	41	Junction Box	1
2	Main Lid Screw Cover	2	42	Junction Box Waterproof Spacer	1
3	Main Lid Screw	1	43	Junction Box Cover	2
4	Temperature Gauge Housing	1	44	Swivel Caster With Brake	1
5	Temperature Gauge	1	45	Lamp Fix Bracket	1
6	Logo	2	46	Side Panel, Left	1
7	Main Lid Handle Heat Insulating Cover	2	47	Door Hinge Bracket, Left	1
8	Main Lid Handle Heat Insulating Spacer	2	48	Door Hinge Bracket, Right	1
9	Hood Buffer	1	49	Door Magnet	2
10	Main Lid Handle Seat, Left	1	50	Cart Frame, Front	1
11	Main Lid Handle Seat, Right	1	51	Diagonal Bar Barrier	1
12	Main Lid Handle Tube	1	52	Tank Tray Hear Shield	1
13	Rear Baffle	1	53	Tank Bolt	1
14	Rotisserie Burner Pilot	1	54	Tank Tray	1
15	Rotisserie Burner Ignite Wire	1	55	Tank Tray Slide Bracket, Left	1
16	Rotisserie Burner	1	56	Tank Tray Slide Bracket, Right	1
17	Rotisserie Burner Pilot Cover	1	57	Tank Tray Slide	2
18	Rotisserie Burner Pilot Bracket	1	58	Gas Tank Tray, Button	1
19	Rotisserie Orifice W/Brass Elbow	1	59	Front Door, Left	1
20	Rotisserie Bruner Flex Gas Line	1	60	Front Door, Right	1
21	Side Shelf Push Bar Seat	2	61	Lighting Rod	1
22	Side Shelf Push Bar	1	62	Lighting Rod Cover	1
23	Side Shelf, Left	1	63	Transformer Supporting Box	1
24	Side Shelf Front Panel, Left	1	64	Transformer Box Waterproof Spacer	1
25	Top Side Panel w / Bracket, Left	1	65	Transformer Supporting Box Cover	1
26	Main Control Panel	1	66	Transformer	1
27	Light Switch	1	67	Cable Strainer	1
28	Control Knob	7	68	Caster	2
29	Main Gas Valve	5	69	Bottom Panel, LP	1
30	Rotisserie Gas Valve	1	70	Side Panel, Right	1
31	Front Baffle	1	71	Rubber Grommet	2
32	Main Manifold	1	72	Back Panel	1
33	Side Burner Hose	1	73	Back Panel, Top	1
34	Greasy Tray	1	74	Side Burner Control Panel	1
35	Grease Slide Panel, Bottom	1	75	Side Manifold	1
36	Utility Drawer Bracket	2	76	Side Gas Valve	1
37	Utility Drawer Slide	2	77	Sear Burner Igniter Wire	1
38	Utility Drawer	1	78	Sear Burner	1
39	Utility Drawer / Door Handle	3	79	Side Burner Bowl Assembly Frame	1
40	Grease Slide Panel, Top	1	80	Greasy Tray	1

REF #	DESCRIPTION	QTY	REF #	DESCRIPTION	QTY
81	Side Burner Cooking Grid	1	89	Igniter Wire Cover	2
82	Side Burner Lid	1	90	Mini Bracket	1
83	Side Burner Lid Hinge	1	91	Main Burner	5
84	Pulse Ingiter Module	1	92	Flame Tamer	5
85	Regulator, LP	1	93	Cooking Grid With Hole	3
86	Top Side Panel W/ Bracket, Right	1	94	Warming Rack	1
87	Main Burner Bowl Assembly	1	95	Manual	1
88	Lamp	1	96	Hardware Pack	1



MAKE SURE ALL CONTROL KNOBS & CYLINDER VALVE ARE IN OFF POSITION BEFORE CONVERTING

This grill is portable and configured for use with Liquid Propane (LP Gas), which is delivered to the grill from removable tanks (LP tanks and their use are covered elsewhere in this manual). If a Natural Gas connection is available, the user may wish to change the gas delivery system to the more permanent Natural Gas supply.

This grill is certified for use with either Liquid Propane (LP Gas) or Natural Gas and comes complete with the necessary parts to convert the grill for use with Natural Gas hose and regulator sold separately. The Nexgrill patented Conversion Valves allows the use of Natural Gas without replacing the burners or entire valve system.

The process of converting is relatively simple and can be accomplished by any handy homeowner. Nexgrill suggests, however, that a qualified gas technician do the conversion. Your warranty may be voided if the conversion is improperly completed. Please retain the parts supplied with the grill and these instructions so the technician can do the conversion.

Orifice Chart

The different burner valves in this grill have different BTU ratings. This means that the quantity of gas coming from each orifice varies in order to create the BTU's. The holes in the orifices themselves are drilled to different sizes so as to allow the proper amount of gas to flow through them. Please note the chart below to give an easy reference for the various orifice opening sizes for the different valves in the grill.

Orifice Sizes and BTU Ratings				
Model Number 720-0578				
	LP		NG	
Components	Orifice Size	BTU	Orifice Size	BTU
Main Burner	0.94 mm	10,000	1.55 mm	10,000
Side Burner	1.15 mm	15,000	1.9 mm	15,000
Rear Burner	0.95 mm	10,000	1.55 mm	10,000

Instructions for Converting to Natural Gas

Tools required for converting from LP to NG



- Screwdriver + is used for removing the screws
- 8mm Nut Driver is used for changing the main tube burner orifice
- Screwdriver - is used for turning the Low/High Flame
- 14mm Wrench is used for releasing the brass adapter of flex tube
- 10mm Wrench is used for changing the rear burner orifice
- Allen Key is used for removing the control knobs, included with grill



- 18mm Wrench is used for fixing the side burner orifice nut (Included in package)
- 6mm Wrench is used for changing the side burner orifice (Included in package)

Main Tube Burner Conversion

Steps:

1. Remove the rotisserie kit, warming rack, cooking grids, flame tamers and tube burners from the firebox.



2. Locate orifice on end of valve and remove by turning counterclockwise with a 8mm Nut Driver.



CAUTION!

When converting the grill, screw the orifice in and out of the stem gently due to the breakable thread.

3. Insert NG orifice and screw in tightly.



4. Replace tube burners.



Side Burner Conversion

Steps:

1. Fix orifice nut with 18mm Wrench. Then locate orifice and remove by turning counterclockwise with 6mm Wrench.



2. Insert NG orifice by hand, then secure and turning clockwise with 6mm Wrench in tightly.



Rear Burner Conversion

In order to change a standing pilot from using LP gas to NG, the consumer will need to change the orifices of the **standing pilot** and the corresponding **burner**.

■ Install standing pilot orifice

Steps:

1. Remove the standing pilot cover next to the burner

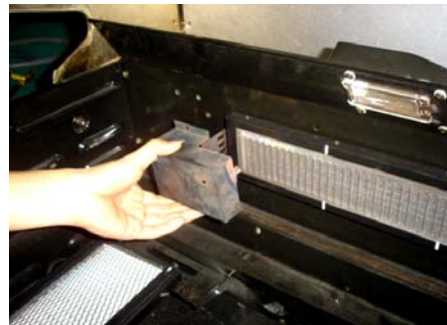
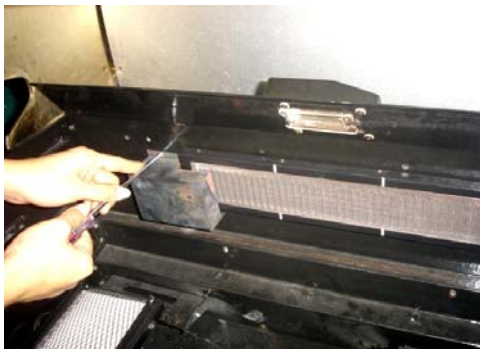

2. The orifice is located in the standing pilot and Unfasten the connection nut of the gas hose and then disconnect it from the standing pilot in order to replace the orifice inside the standing pilot.



3. Replace the orifice for LP gas with a orifice for NG . After the orifice is replaced, fasten the connection nut of the gas hose to the standing pilot; put the standing pilot cover back to its original location .

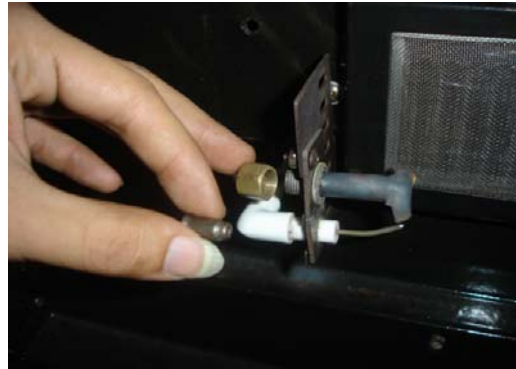
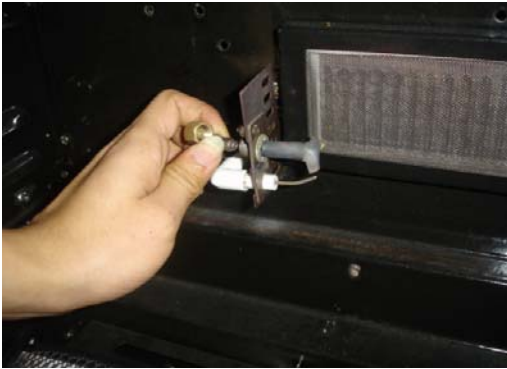

■ Install burner orifice

Steps :

1. Remove the cover of the rear burner venturi by unfastening the screws in the firebox

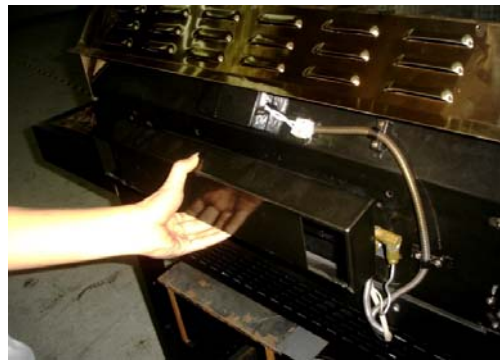

2. Unscrew and remove the orifice



3. Replace the orifice for LP gas with a orifice for NG. After the orifice is replaced, put the cover of the rear burner venturi back to its original location .



For Main tube burner and Side burner Conversion Only

You will need to adjust the High Flame setting screw when converting the grill from Propane to Natural Gas. Please follow the steps as detailed below

1. Remove each Control Knob of main tube burners and side burner by loosening the socket head grub screw holding it to the Valve stem.
2. Turn the valve to the IGNITE/HI position on the Control panel and then use a screwdriver to turn the High Flame Set Screw approximately $\frac{1}{2}$ a turn counterclockwise.
3. Check that burner operates at the new high flame setting - it may be necessary to adjust the screw setting slightly to get the ideal burner flame height.



NG Hose and Regulator Conversion

1. Turn all knobs to OFF, and turn off LP supply at cylinder, then take off the brass adapter of LP regulator from the manifold with a wrench.



2. Attach the NG regulator to the manifold, and screw tightly with the wrench.



3. Connect the 12' NG hose to the NG regulator with the wrench.



HOW TO ORDER REPLACEMENT PARTS

To make sure you obtain the correct replacement part(s) for your gas grill, please refer to the parts list on page 30-31. The following information is required to assure getting the correct part.

- Gas grills model number (see data sticker on grill).
- Part number of replacement part needed.
- Description of replacement part needed.
- Quantity of parts needed.

To obtain replacement parts, contact the dealer from which products was purchased. If dealer service is not available, contact: Nexgrill Industries, Inc. customer service
1-800-913-8999 or fax 909-598-1545

IMPORTANT

Use only factory authorized parts. The use of any part that is not factory authorized can be dangerous. This will also void your warranty.

Keep this assembly and operating instruction manual for convenient referral, and for replacement parts ordering.

CAUTION

Gas valves are present at the factory (valve assembly will be marked accordingly). If you wish to convert at some later date, be sure to contact your gas supplier or grill dealer before making the conversion.

Different orifices must be installed when converting from one type of gas to another. You will also need a data plate indicating what type of gas is used by the grill.

Grill Hints

The doneness of meat, whether rare, medium, or well done, is affected to a large degree by the thickness of the cut. Expert chefs say it is impossible to have a rare doneness with a thin cut of meat.

The cooking time is affected by the kind of meat, the size and shape of the cut, the temperature of the meat when cooking begins, and the degree of doneness desired.

When defrosting meats it is recommended that it be done overnight in the refrigerator as opposed to a microwave. This in general yields a juicier cut of meat.

Use a spatula instead of tongs or a fork to

turn the meat, as a spatula will not puncture the meat and let the juices run out.

To get the juiciest meats, add seasoning or salt after the cooking is finished on each side and turn the meat only once (juices are lost when the meat is turned several times). Turn the meat just after the juices begin to bubble to the surface.

Trim any excess fat from the meat before cooking. To prevent steaks or chops from curling during cooking, slit the fat around the edges at 2-inch intervals.

DO NOT LEAVE THE GRILL UNATTENDED WHILE COOKING.

Grill Cooking Chart

FOOD	WEIGHT OR THICKNESS	HEAT SETTING	APPROXIMATE TIME	SPECIAL INSTRUCTIONS AND TIPS
VEGETABLES				
Fresh				Slice.Dot with butter or margarine Wrap in heavy-duty foil.Grill,turning occasionally
Beets		low	12 to 20 minutes	
Carrots				
Turnips				Grill,turning once.Brush Occasionally With melted butter or margarine
Onion	1/2 inch slices	low	8 to 20 minutes	
Potatoes				Wrap individually in heavy- Duty foil.Grill,rotating Occasionally.
Sweet	Whole	low	40 to 60 minutes	
White	6 To 8 ounces	High	45 to 60 minutes	
Frozen				Dot with butter or margarine Wrap in heavy-duty foil.Grill Turning occasionally
Asparagus		low	15 to 30 minutes	
Broccoli				
Brussels				
Sprouts				
Green beans				
Peas				
French fries		low	15 to 30 minutes	Place in aluminum foil pan. Grill, stirring occasionally.
MEATS				
Beef				
Hamburgers	1/2 to 3/4inch	low	10 to 18 minutes	Grill,turning once when juices rise to the surface Do not leave hamburgers unattended since a flare-up could occur quickly
		High	8 to 15 minutes	
Steaks				
Rib eye,				

Grill Cooking Chart

continued

FOOD	WEIGHT OR THICKNESS	HEAT SETTING	APPROXIMATE TIME	SPECIAL INSTRUCTIONS AND TIPS
Tenderloin, Porterhouse, T-Bone, Sirloin				Remove excess fat from edge. Slash remaining fat at 2-inch intervals.
Rare	1 inch	High	8 to 14 minutes	Grill, turning once.
	1-1/2 inch	High	11 to 18 minutes	
Medium	1 inch	Low to	12 to 22 minutes	
	1-1/2 inch	High	16 to 27 minutes	
Well-done	1 inch	Low	18 to 30 minutes	
	1-1/2 inches	Low	16 to 35 minutes	
Lamb Chops & Steaks				Remove excess fat from edge. Slash remaining fat at 2-inch intervals.
Rare	1 inch	High	10 to 15 minutes	Grill, turning once.
	1-1/2 inch	High	14 to 18 minutes	
Medium	1 inch	Low to	13 to 20 minutes	
	1-1/2 inch	High	18 to 25 minutes	
Well-done	1 inch	Low	17 to 30 minutes	
pork Chops	1 inch	Low	20 to 30 minutes	remaining fat at 2-inch intervals. Grill, turning once. Cook well done.
Well-done	1-1/2 inches	Low	30 to 40 minutes	
Ribs		Low	30 to 40 minutes	Grill, turning occasionally. During last few minutes brush with barbecue sauce, turn several times.
Pork Ham steaks				
(precooked)	1/2 inch slices	High	4 to 8 minutes	Remove excess fat from edge. Grill, turning once.
Hot dogs		Medium	5 to 10 minutes	Slit skin. Grill, turning once.
POULTRY				
Broiler/fryer	2 to 3 pounds	Low	1 to 1-1/2 hours	brushing frequently marinade.
Halved or done		Low	40 to 60 minutes	
Breasts well-done		Low	30 to 45 minutes	

FOOD	WEIGHT OR THICKNESS	HEAT SETTING	APPROXIMATE TIME	SPECIAL INSTRUCTIONS AND TIPS
FISH AND SEAFOOD				
Steaks				Grill, turning once. Brush with melted butter, margarine or oil To keep moist.
Halibut	3/4 to 1 inch	Medium to	8 to 15 minutes	
Salmon		High		
Swordfish				
Whole				
Catfish 4 to 8 ounces	4 to 8 ounces	Medium to	12 to 20 minutes	Grill turning once. Brush with Melted Butter, margarine or oil.
Rainbow trout		High		

BBQ SALMON

2 large salmon steaks
 2 tbs. Oil
 Salt & pepper
 2 oz. thin bacon slices
 2 tbs. Butter
 1 tbs. Lemon juice
 Spring of parsley
 Lemon wedges

Preheat the BBQ.

Brush the steaks with oil and season with salt and pepper. Place on BBQ grill and cook for 10 minutes, turning steaks over halfway cooking time.

Meanwhile fry the bacon in a pan on the side burner. Drain on paper towels. Meld the butter in a small saucepan taking care not to discolor it. Arrange the fish and bacon on serving plates. Pour the butter over and sprinkle with lemon juice. Garnish with parsley springs and lemon wedges. Serve with boiled potatoes tossed in butter and sprinkled with chopped parsley and a crisp lettuce salad.

Note: Substitute catfish, halibut or cod for salmon.

BAKED CHILI CORN

6 medium ears corn, husked
 3 tbs. Butter or margarine, melted
 Dash ground cumin
 Dash ground coriander

About ½ hour before cooking, turn the butter on for grill. Place each corn on a heavy-duty foil. In a bowl, combine remaining ingredients. Mix well. Brush 1-1/2 tsp. Butter mixture over each ear. Close foil and fold up ends to seal. Place on grill. Cook, turning packets occasionally 10 to 12 minutes or until cooked through.

TANGY SEAFOOD KABOBS

1 lb. Large shrimp, shelled & deveined

¾ lbs. sea scallops
 2/3 c. chili sauce
 ¼ c. cider vinegar

butter and sprinkled with chopped parsley and a crisp lettuce salad.

In medium bowl, combine shrimp and scallops. In small bowl combine chili sauce and next six ingredients. Pour over seafood. Toss to coat. Cover, refrigerate 2 hours.

3 tbs. chopped parsley
 1 tbs. vegetable oil
 1 tbs. Worcestershire sauce
 ½ tsp. prepared horseradish
 1 cove garlic, minced
 1 20 oz. Can pineapple chunks in juice, drained half hour before cooking, turn the burner to the grill on full. Drain seafood reserving marinade. On each of twelve 10" skewers, thread 2 shrimps and 2 scallops, alternating with pineapple chunks. Place skewers on grill. Cook 7-10 minutes, often basting and turning.

PORK CHOPS

4 Pork chops
 Marinade
 1 large onion
 2 tbs. lemon juice or vinegar
 2 tbs. oil
 ½ tsp. powdered mustard
 2 tsp. Worcestershire sauce
 ½ tsp. freshly ground black pepper
 1 tsp. sugar
 ½ tsp. paprika
 1 clove garlic

Peel, grate onion, and add rest of the ingredients except the pork chops. Mix well. Pour over chops and marinate one hour in a cool place. Turn the BBQ grill on full. Heat 10 minutes.

BBQ the chops brushing with the marinade occasionally. Serve with mixed salad, dressed with vinaigrette flavored with fresh dill.

BARBECUED LONDON BROIL

4 to 6 servings
 ¾ c. Italian dressing
 1 tsp. Worcestershire sauce
 1 tsp. dry mustard
 ¼ tsp. thyme, crushed
 1 medium onion, sliced
 1 pound flank steak, scored
 2 tbs. butter, melted

Combine first 4 ingredients, add onion and marinate flank steak with it. Refrigerate at least 4 hours or overnight. Remove steak and grill on your preheated BBQ grill. Grill 5 to 7 minutes on each side basting frequently with the marinade. In the meantime sauté onions from the marinade in butter in a skillet on your side burner for 3 minutes. To serve, slice steak diagonally into thin slices, sprinkle onions over top. Garnish with vegetable kabobs.

BARBECUED POTATOES and CHEESE

1-1/2 cups shredded cheddar cheese
 1 can (10-3/4 oz.) condensed cream of mushroom soup
 1/3 cup milk
 2 tbs. barbecue sauce
 ¼ tsp. oregano
 ¼ tsp. salt
 1/8 tsp. pepper
 4 cups thinly sliced potatoes (4 medium-sized potatoes)

Preheat grill. Combine cheese, condensed soup, milk, BBQ sauce, oregano, salt and pepper in a large mixing bowl. Stir in potatoes until well coated. Turn into well buttered 1-1/2 quart rectangular baking dish. Cover dish with aluminum foil. Bake covered 25 minutes on medium with the lid of your BBQ grill closed. Remove foil and continue baking 15 minutes longer or until potatoes are tender. Let stand 5 minutes before serving.

VEGETABLE KABOBS

3 medium-sized zucchini
 12 cherry tomatoes
 12 fresh mushrooms
 Grated Parmesan cheese

Parboil whole zucchini 5 minutes on your side burner or until just tender. Drain and cut into 1/2 inch slices. Thread zucchini, tomatoes and mushrooms alternately on each of six skewers. Brush with marinade made of Italian dressing, Worcestershire sauce, mustard and thyme. Grill 5 to 7 minutes turning and basting occasionally. Sprinkle liberally with Parmesan cheese.

FAJITAS

1-1/2 lb. flank steak or boned chicken breasts
 2 tbs. oil
 1/2 cup lime juice
 1/2 tsp. salt
 1/2 tsp. celery salt
 1/4 tsp. garlic powder
 1/2 tsp. pepper
 1/4 tsp. oregano
 1/4 tsp. cumin
 Flour tortillas lemon

Pound flank steak to 1/4 inch thickness or flatten chicken breasts. Mix oil, lime juice and seasonings in a zip lock bag. Add meat and shake bag to coat the meat. Refrigerate overnight or at least 6 to 8 hours. Wrap tortillas in foil. Remove meat from marinade. Cook on a pre-heated gas grill for 5 to 8 minutes on each side. While meat is cooking, heat tortillas on grill. Slice meat across grain in thin slices. Place on hot platter. Squeeze lemon juice over. Wrap meat and any of the following toppings in tortillas: chopped tomatoes, guacamole, sour cream, taco sauce.

BEEF AND LAMB KABOBS

Serve 4

1/2 lb. boneless sirloin or beef cut into 1" cubes
 1/2 lb. boneless loin of lamb cut into 1" cubes
 2/3 c. water, divided
 1/4 c. chopped onion
 2 tbs. soy sauce
 1/4 c. vegetable oil, divided
 1 tbs. dark brown sugar
 1 tbs. fresh lemon juice
 2 cloves garlic, minced
 1/4 tsp. ground cumin
 1/4 tsp. ground coriander
 1/4 tsp. ground turmeric
 1/8 tsp. ground red pepper
 1/8 tsp. ground ginger
 1 red pepper cut into chunks
 1 large banana, cut into chunks
 8 small mushrooms
 1/3 c. smooth peanut butter

In blender, process 1/3 c. water, onion, soy sauce, 2 tsp. oil and the next 8 ingredients until smooth. Pour over meat cubes and marinate about 4 hours, turning occasionally. Drain and reserve marinade. Onto to four 12" skewers alternately thread meat, pepper, banana and mushrooms. Preheat grill. Brush the kabobs with oil. Grill 7-8 minutes each side.

Bring marinade to boil on the side burner in a saucepan. Add remaining 1/3 c. water and peanut butter. Stir to blend. Heat through. If sauce gets too thick, add 1 tbs. water. Serve sauce with kabobs.

EGGPLANT CAVIAR

1 large eggplant
 2 tbs. olive oil
 2 tbs. wine vinegar
 2 tbs. finely chopped onion
 1/2 clove garlic, minced
 1 medium tomato, chopped salt and pepper
 Roast eggplant on gas grill over medium flame, turning occasionally until thoroughly cooked. This may take 30 minutes. Remove from grill and cool for handling. Strip off the skin and chop eggplant finely. Add all the seasonings. Chill thoroughly and serve on toast.

CHICKEN TANDOORI STYLE

8 large chicken thighs or drumsticks

1 c. plain nonfat yogurt

½ c. lemon juice

2 tsp. salt

½ tsp. cayenne

½ tsp. black pepper

½ tsp. crushed garlic

½ tsp. grated ginger

1 tbs. corn oil

Combine all the ingredients in a large mixing bowl and marinate the chicken for 8 hours in the refrigerator. Drain the chicken and spread on the spit running the rod on the fleshier side of the bone.

Rotis using the rotisserie burner. Cook on medium high heat for 40 minutes basting occasionally with the remainder of the marinade mixture. Serve with sliced onions and lemon wedges.

SPARE RIBS

Marinade:

1 c. soy sauce

½ c. honey

½ c. vinegar

½ c. dry sherry

2 tsp. chopped garlic

2 tsp. sugar

1 c. water

1 chicken bouillon cube

1 can beer for basting sauce

Marinate ribs for 3 hours. Use marinade for basting by adding beer to it. Place pan under the ribs and baste frequently. To cook ribs select lean, meaty ribs and accordion pleat them with your spit. Slide four prong meat hook down the length of spit and tighten. At the beginning of

the rack and to its center, penetrate the second rib with the pointed end of the spit and push it between the meat. Skip a couple and continue the process until the entire rack is accordion pleated. Fasten the second meat hook into the rack. Turn your rotisserie burner on high. Rotis for 50 minutes or until done.

PORK ROAST

Apple cider vinegar basting sauce:

1 c. apple cider vinegar

6 oz. water

½ stick butter

Salt, pepper, parsley and garlic seasoning

2 oz. lemon juice

10 lbs. pork roast

Time: 1-1/2 hours to 2 hours

Bring pork to room temperature before placing it on the spit rod. Place on the rod and test for balance. Light rotis burner. Turn control knob to high. Use the above basting sauce for rotissing.

TURKEY

12 lb. turkey

Beer basting sauce:

1 can beer

12 oz. water

1 stick butter

1 tsp. salt

1 tsp. pepper

½ tsp. garlic flakes

1 tsp. parsley

Thaw the bird completely. Wash inside out. Securely tie the legs and wings. Light rotisserie burner. Turn to high. Combine all the ingredients for basting sauce in a shallow pan. Place it under the turkey 15 to 20 minutes. Cook for approximately 3 hours. The basting sauce combined with turkey drippings makes a delicious gravy.

LIMITED WARRANTY

MODEL 720-0578

STAINLESS STEEL OUTDOOR GAS GRILL

Nexgrill Industries, Inc. warrants to the original consumer purchaser of each Outdoor Gas Grill that when subject to normal residential use, it is free from defects in workmanship and materials for the periods specified below. This warranty excludes grills used in rental or commercial applications.

<u>Component</u>	<u>Warranty Period</u>
Linear Burner:	5 Years
Porcelain Coated flame Tamer	2 Years
Cast Iron Cooking Grids:	2 Years
Valves:	1 Years
Frame, Housing, Cart, Control Panel, Igniter, and related parts:	1 years
All Stainless Steel Parts	1 Years

Our obligation under this warranty is limited to repair or replacement of all parts, at our discretion, during the warranty period. Warranty coverage requires a valid serial number and proof of purchase. The consumer / purchaser will be responsible for all shipping and handling charges, under the terms of this limited warranty. This warranty does not cover normal wear of parts, discoloration of the stainless steel parts or damage resulting from any of the following: failure to properly clean and maintain the product, negligent use or misuse of the product, improper use of the fuel/gas supply, use contrary to the operating instructions, or alteration by any person other than our factory service center. The warranty period is not extended by such repair or replacement.

Nexgrill Industries, Inc. shall not be liable for any incidental or consequential damages for breach of any express or implied warranty on its products. Except to the extent prohibited by applicable law, any implied warranty of merchantability or fitness for a particular purpose on this product is limited to the duration of the above warranty. Some states do not allow the exclusion or limitation of incidental or consequential damages, or allow limitations on how long an implied warranty lasts, so the above limitations or exclusions may not apply to you. This warranty gives you specific legal rights, and you may have other rights, which vary from state to state.

Warranty claim procedure: If you require service or parts for your product, please contact our Warranty Service Center for factory direct assistance. Our hours of operation are Monday – Friday, 8 a.m. - 5 p.m. PST. Our telephone number is 1-800-913-8999, fax number 1-800-598-1545. Please direct any written correspondence to: Nexgrill Industries, Inc. 280 Machlin Court, City of Industry, California, 91789, ATTN: Warranty Service Center.