

This Owner's Manual is provided and hosted by [Appliance Factory Parts](#).



LG LDN22735ST Owner's Manual

[Shop genuine replacement parts for LG LDN22735ST](#)



[Find Your LG Refrigerator Parts - Select From 834 Models](#)

----- Manual continues below -----



LG

REFRIGERATOR

SERVICE MANUAL

CAUTION
BEFORE SERVICING THE UNIT,
READ THE SAFETY PRECAUTIONS IN THIS MANUAL.

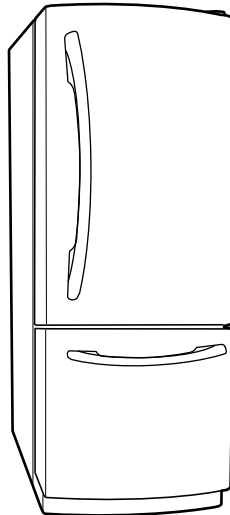

MODELS: LDN22735SW/ SB/ ST

CONTENTS

Safety Precautions.....	2
1. Specifications.....	3
2. Parts Identification.....	4
3. Disassembly.....	6
4. Adjustment.....	8
5. Circuit Diagram.....	10
6. Troubleshooting.....	11
Compressor & Electric Components.....	11
PTC & OLP.....	12
Other Electrical Components.....	13
Service Diagnosis Chart.....	14
Refrigeration Cycle.....	15
7. Description Of Function & Circuit Of MICOM.....	16
8. Refrigerator Exploded View & Service Parts List.....	36

SAFETY PRECAUTIONS

Please read the following instructions before servicing your refrigerator

1. Check the refrigerator for current leakage.
2. To prevent electric shock, unplug before servicing.
3. Always check line voltage and amperage.
4. Use standard electrical components.
5. Don't touch metal products in the freezer with wet hands. This may cause frostbite.
6. Prevent water from spilling onto electric elements or the machine parts.
7. Before tilting the refrigerator, remove all materials from on or in the refrigerator
8. When servicing the evaporator, wear gloves to prevent injuries from the sharp evaporator fins.
9. Service on the refrigerator should be performed by a qualified technician. Sealed system repair must be performed by a CFC certified technician.

1. SPECIFICATIONS

22 cu. ft.

ITEMS	SPECIFICATIONS	ITEMS	SPECIFICATIONS	
DOOR DESIGN	Side Rounded	VEGETABLE TRAY	Opaque Drawer Type	
DIMENSIONS (inches)	32 7/8 X 31 3/4 X 68 1/2 (WxDxH) 22cu.ft	COMPRESSOR	PTC Starting Type	
		EVAPORATOR	Fin Tube Type	
NET WEIGHT (pounds)	246.9 (22cu.ft)	CONDENSER	Wire Condenser	
		REFRIGERANT	R-134a (115 g)	
COOLING SYSTEM	Fan Cooling	LUBRICATING OIL	Freol @ 10G (310 cc)	
TEMPERATURE CONTROL	Micom Control	DEFROSTING DEVICE	SHEATH HEATER	
DEFROSTING SYSTEM	Full Automatic	LAMP	REFRIGERATOR	60 W (2EA)
	Heater Defrost		FREEZER	6 W (2EA)
DOOR FINISH	Embossed Metal, VCM, Stainless			
HANDLE TYPE	Bar, Al			
INNER CASE	ABS Resin			
INSULATION	Polyurethane Foam			

2. PARTS IDENTIFICATION

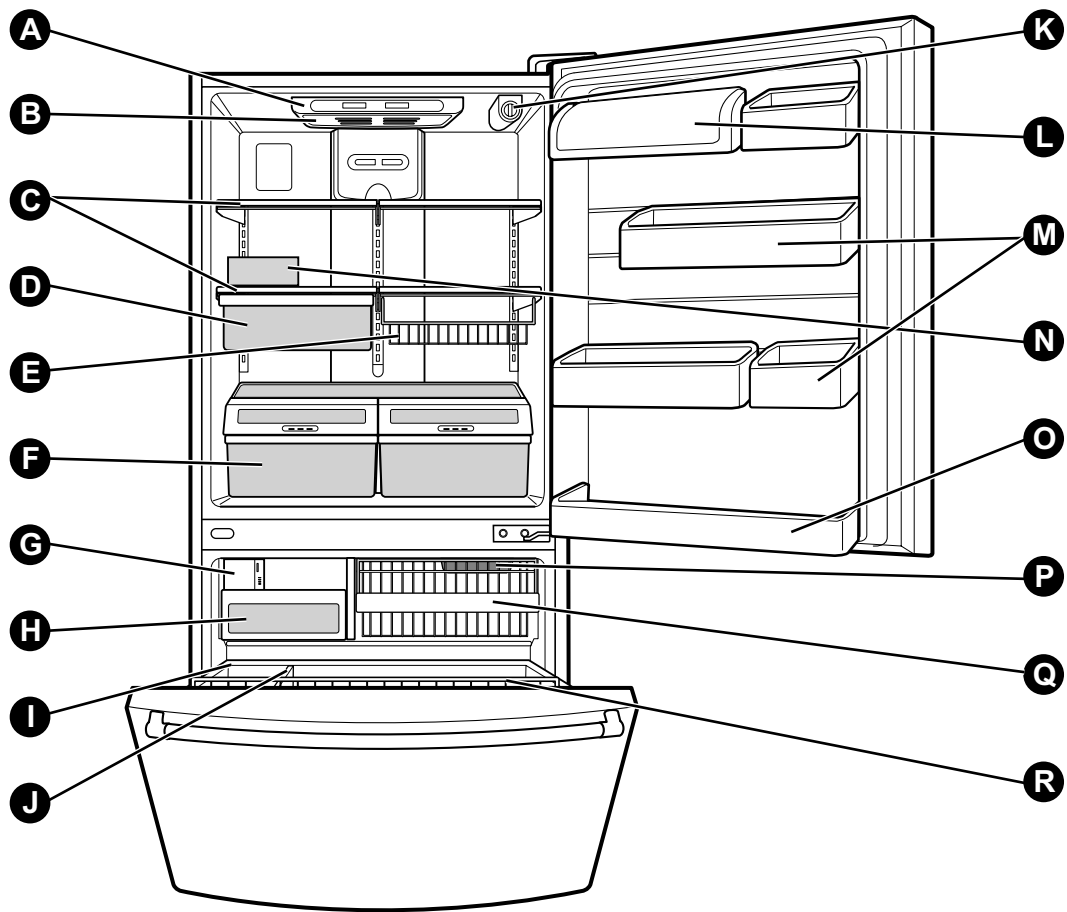

NOTE: This guide covers several different models. The refrigerator you have purchased may have some or all of the items listed below. The locations of the features shown below may not match your model.

A Digital Sensor Control

B Refrigerator Light

C Shelves

D Chef Fresh / Snack Pan*

E Can Dispenser*

F Optibin Crisper
Keeps fruits and vegetable fresh and crisper

G Customcube Icemaker

H Ice Bin

I Durabase

J Divider

K Filter (inside)*

L Dairy Bin

M Design-A-Door

N Egg Box

O Refrigerator Door Rack

P Freezer Light

Q Wire Basket

R Freezer Door Rack (Tilting*)

*on some models

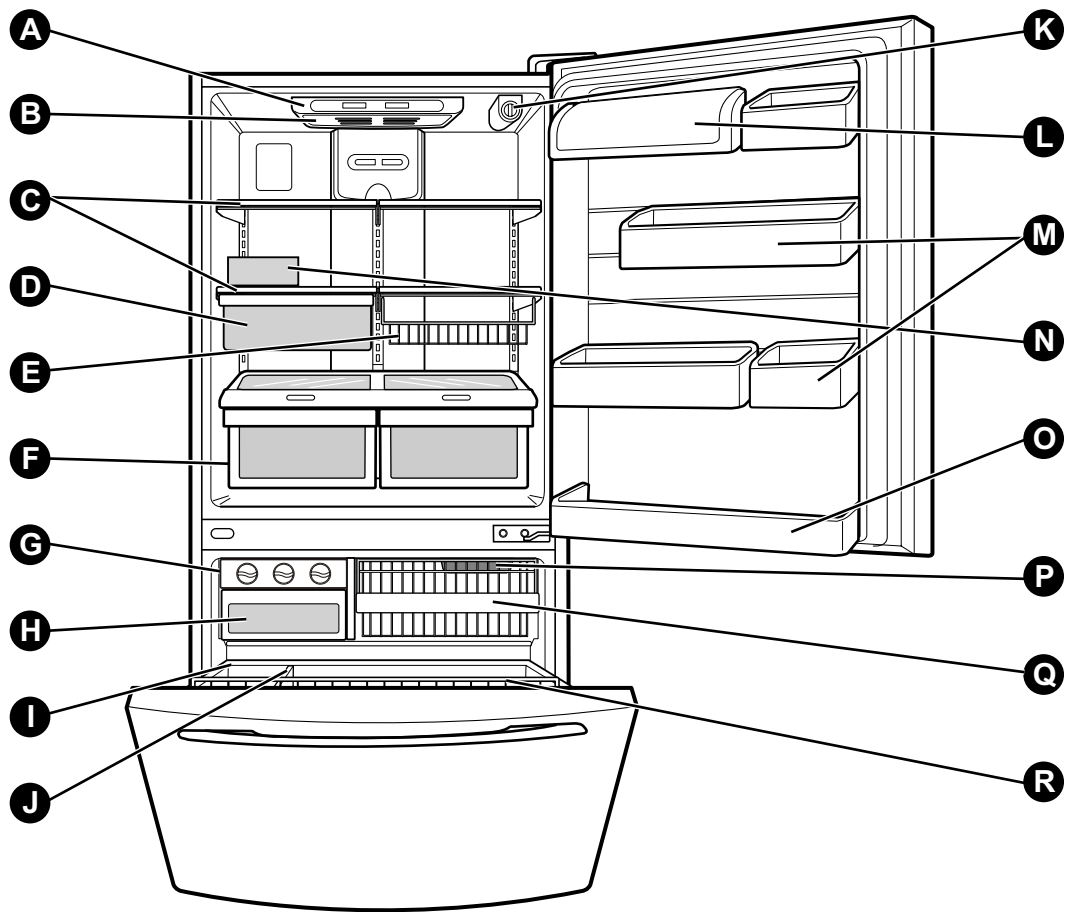

NOTE: This guide covers several different models. The refrigerator you have purchased may have some or all of the items listed below. The locations of the features shown below may not match your model.

A Digital Sensor Control

B Refrigerator Light

C Shelves

D Chef Fresh / Snack Pan*

E Can Dispenser*

F Optibin Crisper
Keeps fruits and vegetable fresh and crisper

G Triple Ice Tray

H Ice Bin

I Durabase

J Divider

K Filter (inside)*

L Dairy Bin

M Design-A-Door

N Egg Box

O Refrigerator Door Rack

P Freezer Light

Q Wire Basket

R Freezer Door Rack (Tilting*)

*on some models

3. DISASSEMBLY

3-1 DOOR

Refrigerator Door

1. Remove the hinge cover by pulling it upwards.
2. Loosen the hexagonal bolts attaching the upper hinge to the body and lift the freezer door.

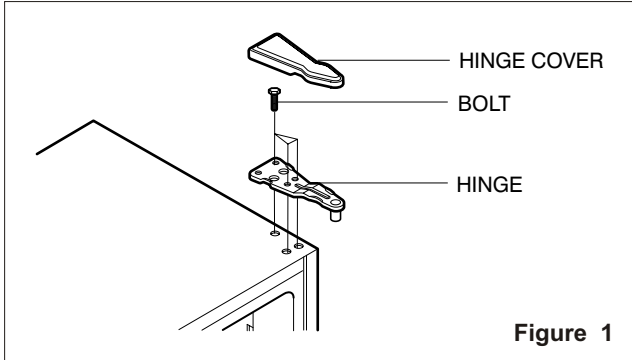

3. Pull out the door gasket to remove from the door foam assembly.

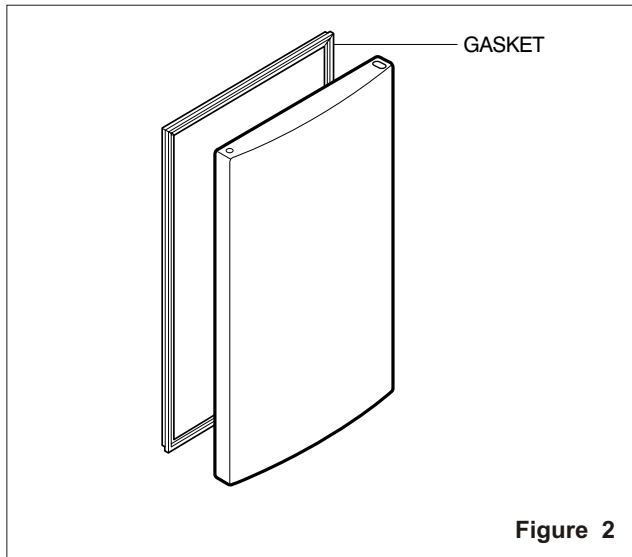

Freezer Door

1. Loosen the hexagonal bolts attaching the lower hinge to the body to remove the refrigerator door only.

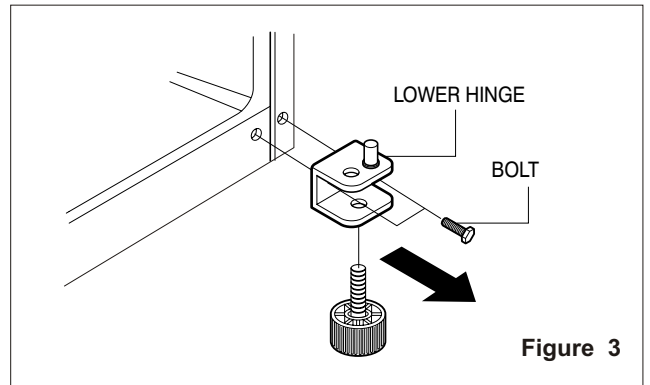

2. Pull out the door gasket to remove from the door foam assembly.

3-2 DOOR SWITCH

1. To remove the door switch, pry it out with a slotted-type driver, as shown in (Figure 4).
2. Disconnect the lead wire from the switch.

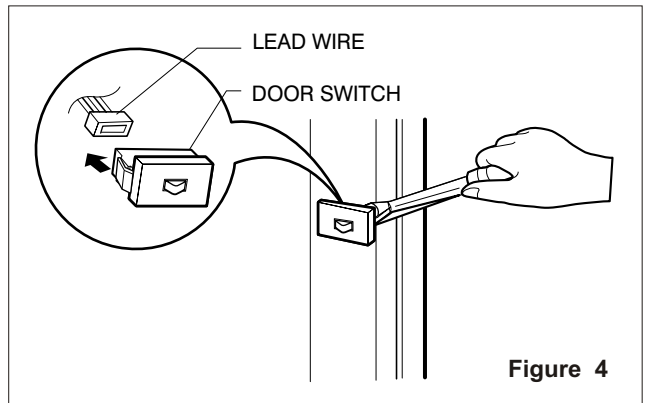

3-3 FAN AND FAN MOTOR

1. Remove the freezer shelf. (If your refrigerator has an icemaker, remove the icemaker first)
2. Remove the grille by pulling it out and by loosening a screw.
3. Remove the Fan Motor assembly by loosening 2 screws and disassemble the shroud.
4. Pull out the fan and separate the Fan Motor and Bracket.

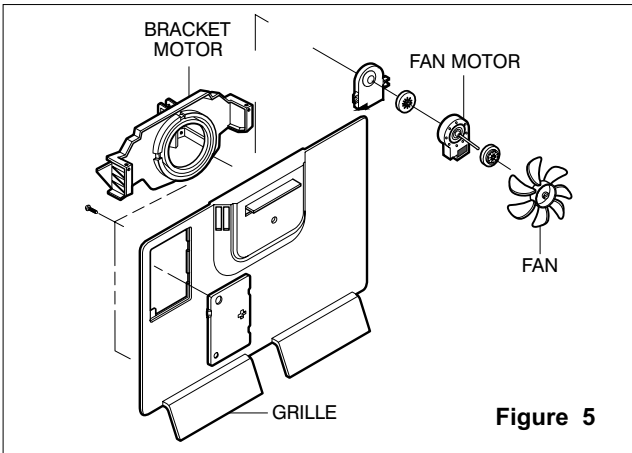

Figure 5

3-4 DEFROST CONTROL ASSEMBLY

Defrost Control assembly consists of Defrost Sensor and FUSE-M.

The Defrost Sensor works to defrost automatically. It is attached to the metal side of the Evaporator and senses its temperature. At 72°C, it turns the Defrost Heater off. Fuse-M is a safety device for preventing over-heating of the Heater when defrosting.

1. Pull out the grille assembly. (Figure 6)
2. Separate the connector with the Defrost Control assembly and replace the Defrost Control assembly after cutting the Tie Wrap. (Figure 7)

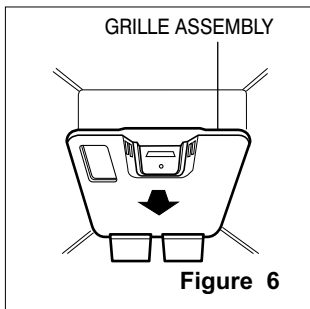

Figure 6

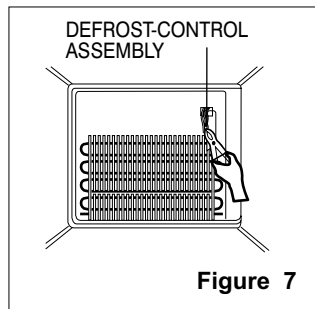

Figure 7

3-5 LAMP

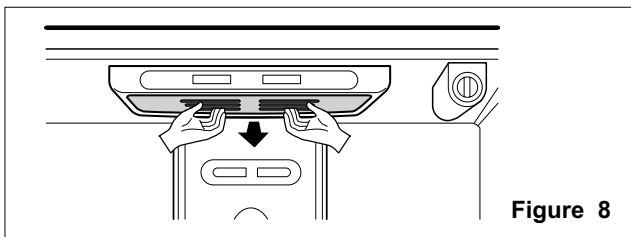

Figure 8

3-5-1 Refrigerator Compartment Lamp

1. Unplug the power cord from the outlet.
2. Remove refrigerator shelves.
3. Release the hooks on both ends of the lamp shield and pull the shield downward to remove it.
4. Turn the lamp counterclockwise.
5. Assemble in reverse order of disassembly. Replacement bulb must be the same specification as the original (Max. 60 W-2EA).

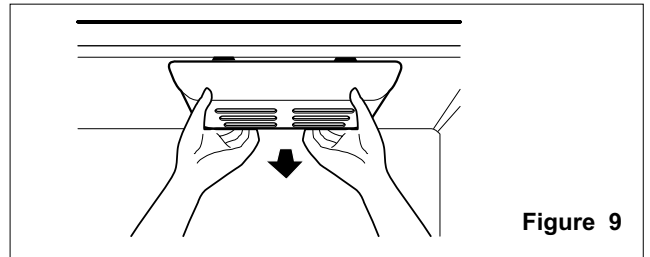

Figure 9

3-5-2 Freezer Compartment Lamp

1. Unplug refrigerator or disconnect power.
2. Reach behind light shield to remove bulb.
3. Replace bulb with a 60-watt appliance bulb.
4. Plug in refrigerator or reconnect power.

3-6 CONTROL BOX-REFRIGERATOR

1. First, remove all shelves in the refrigerator, then remove the Refrigerator control Box by loosening 2 screws.

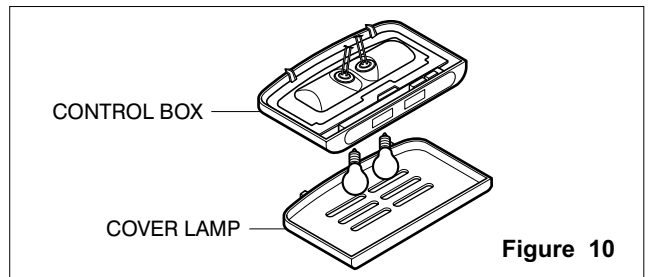

Figure 10

2. Remove the Refrigerator Control Box by pulling it downward.
3. Disconnect the lead wire on the right position and separate the lamp sockets.

3-7 MULTI DUCT

1. Remove an upper and lower Cap by using a flat screwdriver, and loosen 3 screws. (Figure 11)
2. Disconnect the lead wire on the bottom position.

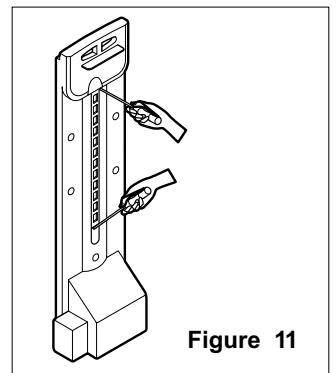

Figure 11

4. ADJUSTMENT

4-1 COMPRESSOR

4-1-1 Role

The compressor intakes low temperature and low pressure gas from the evaporator of the refrigerator and compresses this gas to high-temperature and high-pressure gas. It then delivers the gas to the condenser.

4-1-2 Composition

The compressor includes overload protection. The PTC starter and OLP (overload protector) are attached to the outside of the compressor. Since the compressor is manufactured to tolerances of 1 micron and is hermetically sealed in a dust and moisture-free environment, use extreme caution when repairing it.

4-1-3 Note for Usage

- (1) Be careful not to allow over-voltage and over-current.
- (2) If compressor is dropped or handled carelessly, poor operation and noise may result.
- (3) Use proper electric components appropriate to the Particular Compressor in your product.
- (4) Keep Compressor dry.
If the Compressor gets wet (in the rain or a damp environment) and rust forms in the pin of the Hermetic Terminal, poor operation and contact may result.
- (5) When replacing the Compressor, be careful that dust, humidity, and soldering flux don't contaminate the inside of the compressor. Dust, humidity, and solder flux contaminate the cylinder and may cause noise, improper operation or even cause it to lock up.

4-2 PTC-STARTER

4-2-1 Composition of PTC-Starter

- (1) PTC (Positive Temperature Coefficient) is a no-contact semiconductor starting device which uses ceramic material consisting of BaTiO₃.
- (2) The higher the temperature is, the higher the resistance value. These features are used as a starting device for the Motor.

4-2-2 Role of PTC-Starter

- (1) The PTC is attached to the Sealed Compressor and is used for starting the Motor.
- (2) The compressor is a single-phase induction motor. During the starting operation, the PTC allows current flow to both the start winding and main winding.

4-2-3 PTC-Applied Circuit Diagram Starting Method for the Motor

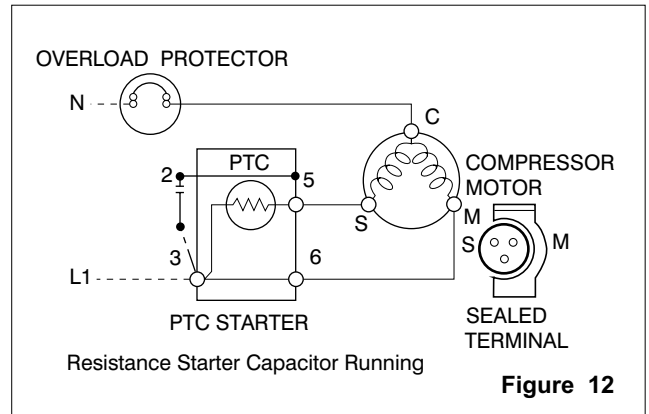

4-2-4 Motor Restarting and PTC Cooling

- (1) It requires approximately 5 minutes for the pressure to equalize before the compressor can restart.
- (2) The PTC device generates heat during operation. Therefore, it must be allowed to cool before the compressor can restart.

4-2-5 Relation of PTC-Starter and OLP

- (1) If the compressor attempts to restart before the PTC device is cooled, the PTC device will allow current to flow only to the main winding.
- (2) The OLP will open because of the over current condition. This same process will continue (3 to 5 times) when the compressor attempts to restart until the PTC device has cooled. The correct OLP must be properly attached to prevent damage to the compressor.
Parts may appear physically identical but could have different electrical ratings. Replace parts by part number and model number. Using an incorrect part could result in damage to the product, fire, injury, or possibly death.

4-2-6 Note for Using the PTC-Starter

- (1) Be careful not to allow over-voltage and over-current.
- (2) Do not drop or handle carelessly.
- (3) Keep away from any liquid.
If liquid such as oil or water enters the PTC, PTC materials may fail due to breakdown of their insulating capabilities.
- (4) If the exterior of the PTC is damaged, the resistance value may be altered. This can cause damage to the compressor and result in a no-start or hard-to-start condition.
- (5) Always use the PTC designed for the compressor and make sure it is properly attached to the compressor. Parts may appear physically identical but could have different electrical ratings. Replace parts by part number and model number. Using an incorrect part could result in damage to the product, fire, injury, or possibly death.

4-3 OLP (OVERLOAD PROTECTOR)

4-3-1 Definition of OLP

- (1) OLP (OVERLOAD PROTECTOR) is attached to the Compressor and protects the Motor by opening the circuit to the Motor if the temperature rises and activating the bimetal spring in the OLP.
- (2) When high current flows to the Compressor motor, the Bimetal works by heating the heater inside the OLP, and the OLP protects the Motor by cutting off the current flowing to the Compressor Motor.

4-3-2 Role of the OLP

- (1) The OLP is attached to the Sealed Compressor used for the Refrigerator. It prevents the Motor Coil from being started in the Compressor.
- (2) For normal operation of the OLP, do not turn the Adjust Screw of the OLP in any way.

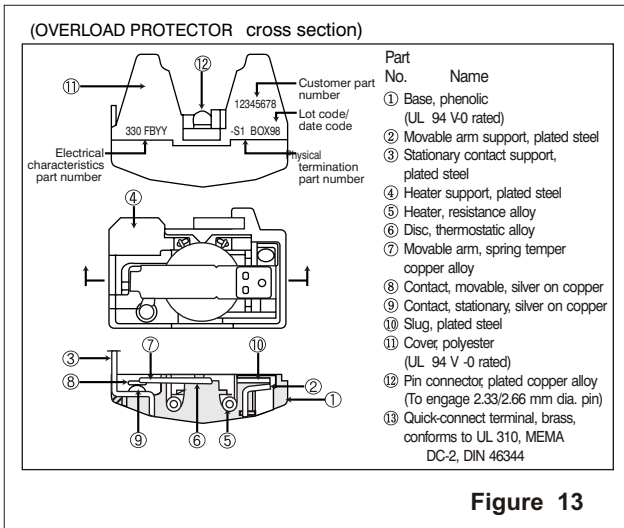

4-4 TO REMOVE THE COVER PTC

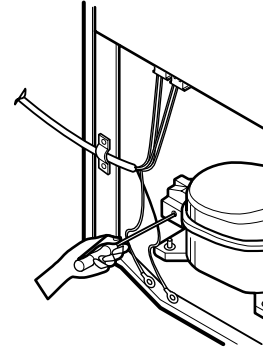

- 1) Remove the Cover Back M/C.
- (2) Remove the screw on Cover PTC.

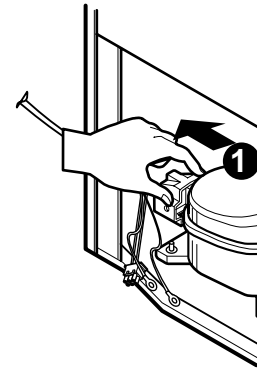

- (3) Remove two Housings on upper part of Cover PTC.
- (4) Take out the cover PTC from upper to lower position like .

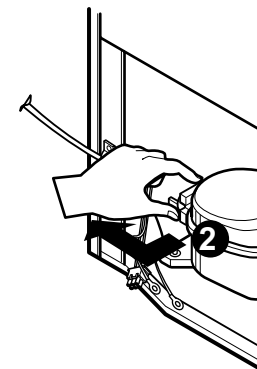

- (5) Turn 45 i in the direction of and take it out.
- (6) Assembly in reverse order of disassembly.

5. CIRCUIT DIAGRAM

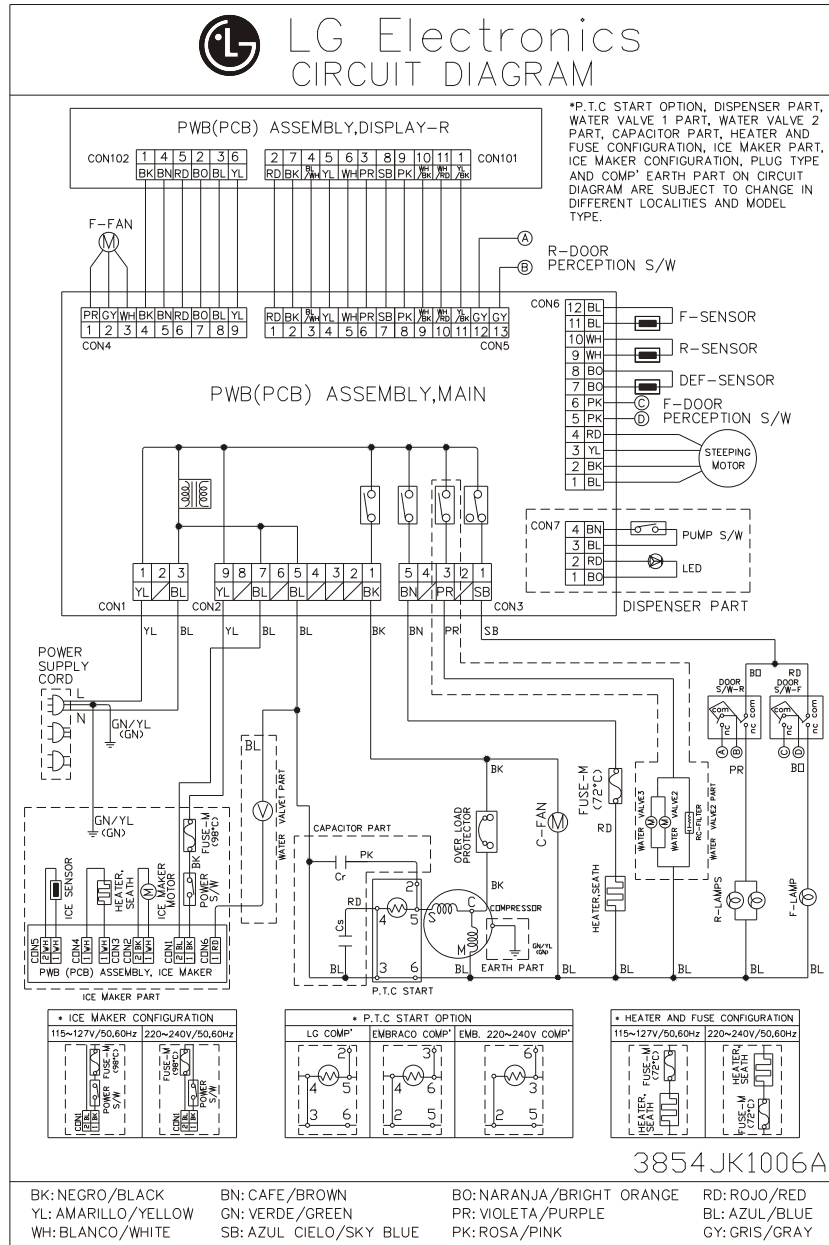

6. TROUBLESHOOTING

6-1 COMPRESSOR AND ELECTRIC COMPONENTS

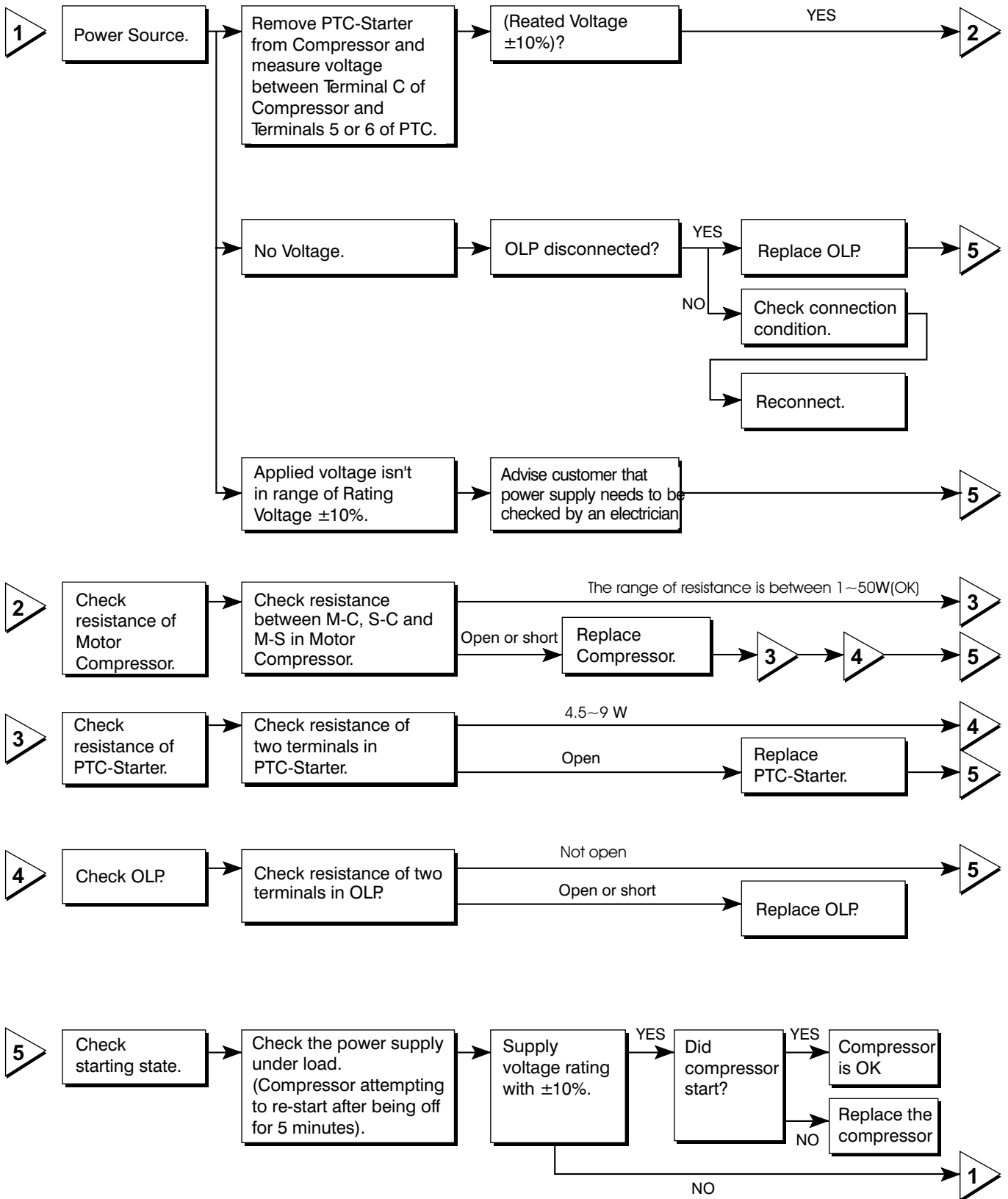

6-2 PTC AND OLP

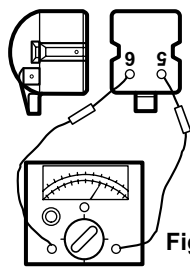
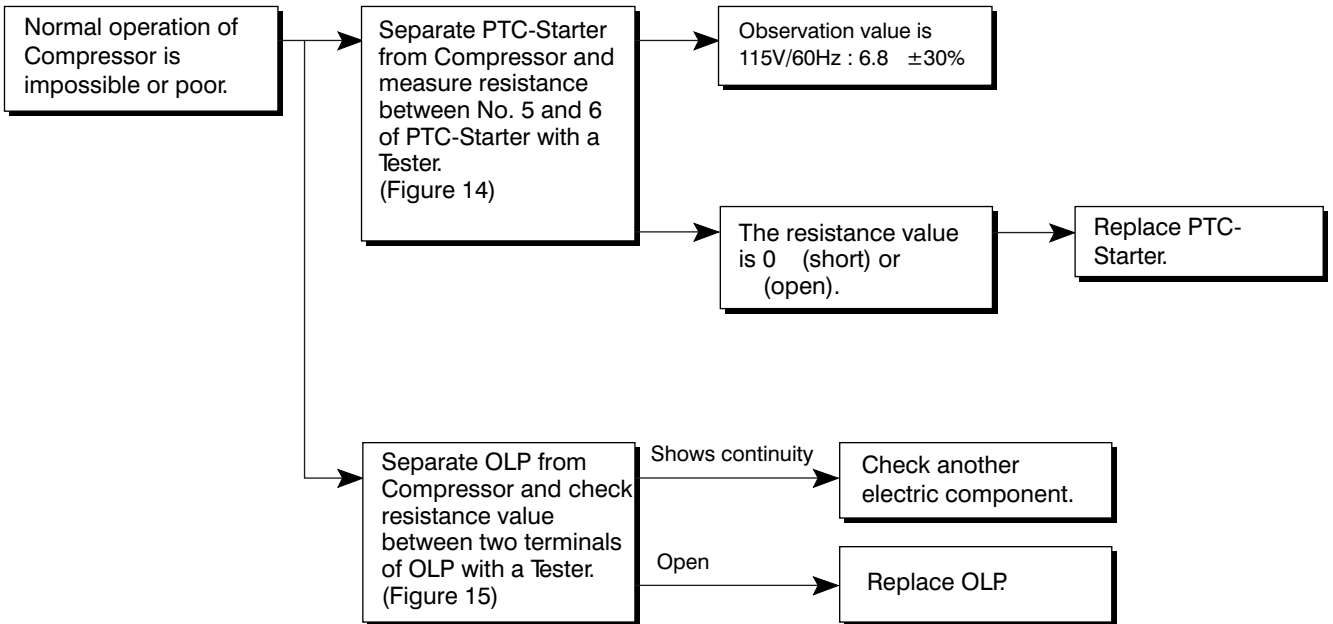

Figure 14

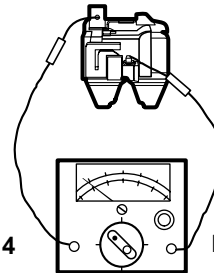
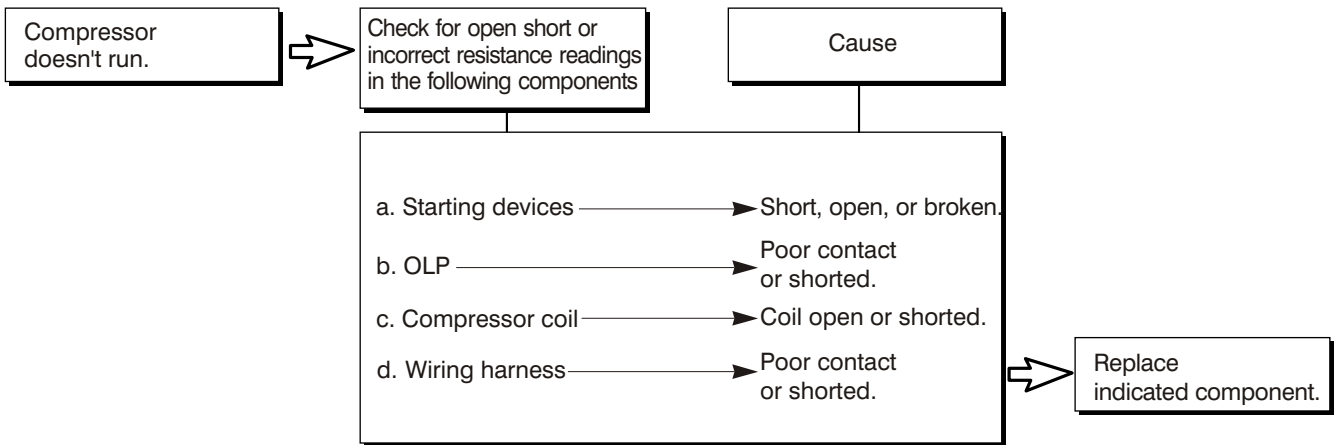

Figure 15

6-3 OTHER ELECTRICAL COMPONENTS

Not cooling at all



Poor cooling performance

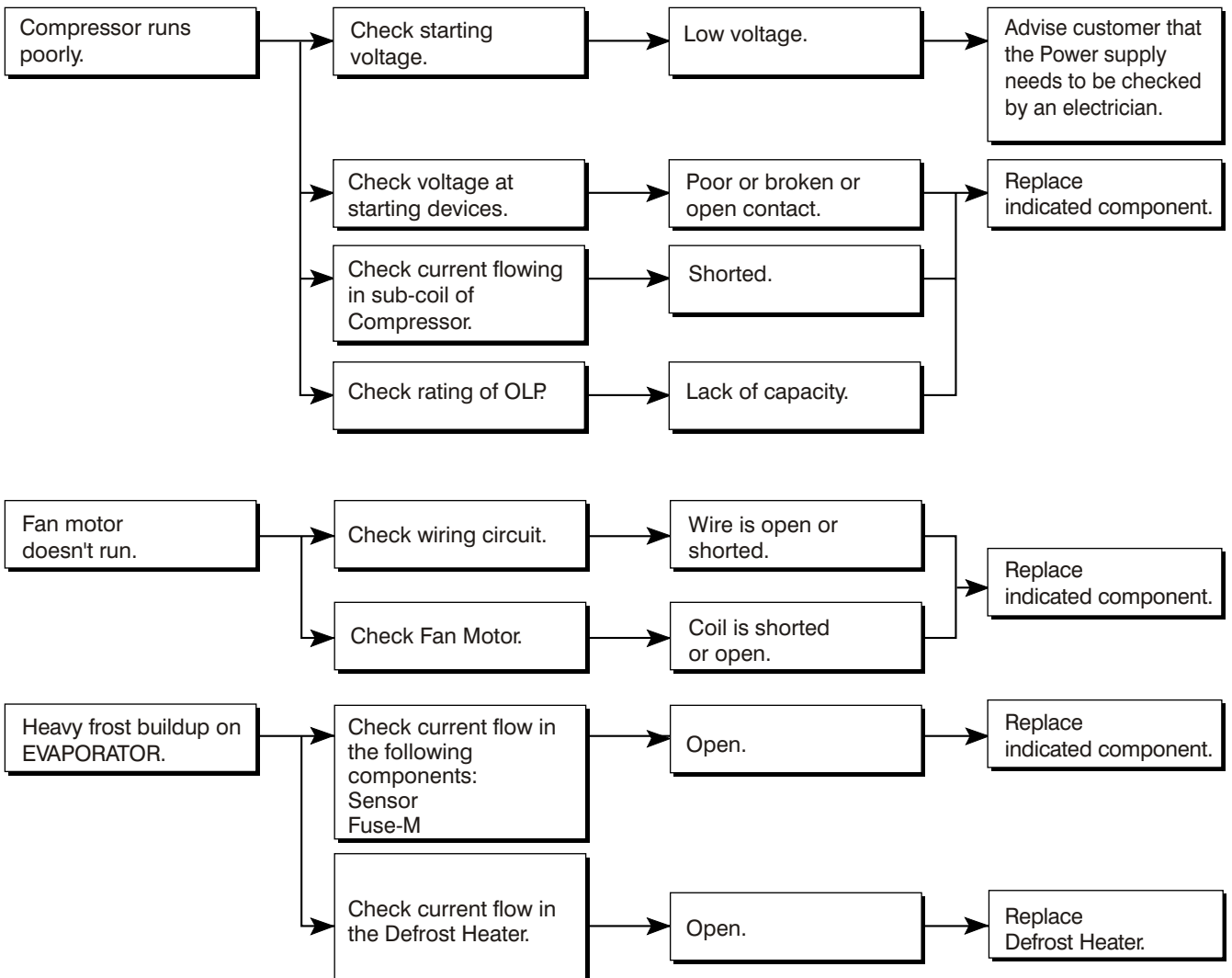

6-4 SERVICE DIAGNOSIS CHART

COMPLAINT	POINTS TO BE CHECKED	REMEDY
No Cooling.	<ul style="list-style-type: none"> • Is the power cord unplugged from the outlet? • Check if the power switch is set to OFF • Check if the fuse of the power switch is shorted. • Measure the voltage of the power outlet. 	<ul style="list-style-type: none"> • Plug into the outlet. • Set the switch to ON. • Replace the fuse. • If the voltage is low, correct the wiring.
Cools poorly.	<ul style="list-style-type: none"> • Check if the unit is placed too close to the wall. • Check if the unit is placed too close to the stove, gas cooker, or in direct sunlight. • Is the ambient temperature too high or the room door closed? • Check if food put in the refrigerator is hot. • Did you open the door of the unit too often or check if the door is sealed properly? • Check if the Control is set to Warm position. 	<ul style="list-style-type: none"> • Place the unit about 4 inches (10 cm) from the wall. • Place the unit away from these heat sources. • Lower the ambient temperature. • Put in foods after they have cooled down. • Don't open the door too often and close it firmly. • Set the control to Recommended position.
Foods in the Refrigerator are frozen.	<ul style="list-style-type: none"> • Is food placed in the cooling air outlet? • Check if the control is set to colder position. • Is the ambient temperature below 41°F(5°C)? 	<ul style="list-style-type: none"> • Place foods in the high-temperature section. (front part) • Set the control to Recommended position. • Set the control to Warm position.
Condensation or ice forms inside the unit.	<ul style="list-style-type: none"> • Is liquid food sealed? • Check if food put in the refrigerator is hot. • Did you open the door of the unit too often or check if the door is sealed properly? 	<ul style="list-style-type: none"> • Seal liquid foods with wrap. • Put in foods after they have cooled down. • Don't open the door too often and close it firmly.
Condensation forms in the Exterior Case.	<ul style="list-style-type: none"> • Check if the ambient temperature and humidity of the surrounding air are high. • Is there a gap in the door gasket? 	<ul style="list-style-type: none"> • Wipe moisture with a dry cloth. It will disappear in low temperature and humidity. • Fill up the gap.
There is abnormal noise.	<ul style="list-style-type: none"> • Is the unit positioned in a firm and even place? • Are any unnecessary objects placed in the back side of the unit? • Check if the Drip Tray is not firmly fixed. • Check if the cover of the compressor enclosure in the lower front side is taken out. 	<ul style="list-style-type: none"> • Adjust the Leveling Screw, and position the refrigerator in a firm place. • Remove the objects. • Fix the Drip Tray firmly in the original position. • Place the cover in its original position.
Door does not close well.	<ul style="list-style-type: none"> • Check if the door gasket is dirty with an item like juice. • Is the refrigerator level? • Is there too much food in the refrigerator? 	<ul style="list-style-type: none"> • Clean the door gasket. • Position in the firm place and level the Leveling Screw. • Make sure food stored in shelves does not prevent the door from closing.
Ice and foods smell unpleasant.	<ul style="list-style-type: none"> • Check if the inside of the unit is dirty. • Are foods with a strong odor unwrapped? • The unit smells of plastic. 	<ul style="list-style-type: none"> • Clean the inside of the unit. • Wrap foods that have a strong odor. • New products smell of plastic, but this will go away after 1-2 weeks.

Other possible problems:

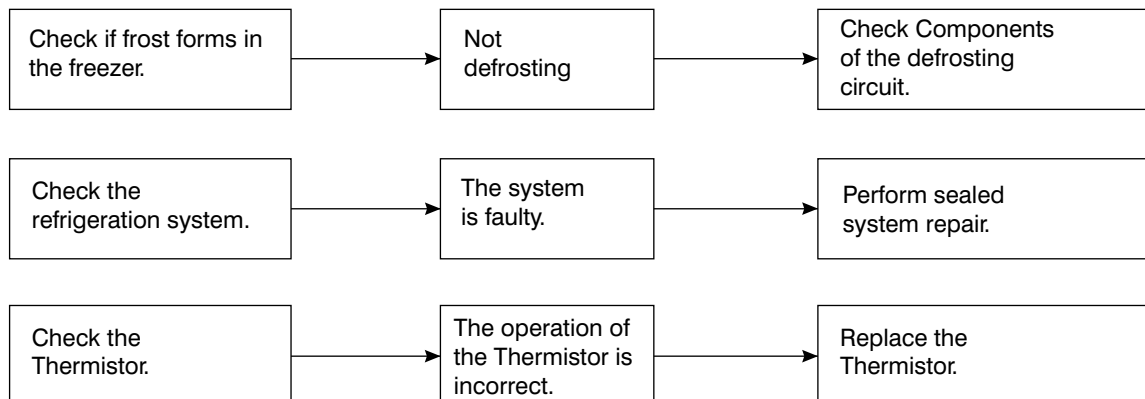

6-5 REFRIGERATION CYCLE

Troubleshooting Chart

CAUSE		STATE OF THE UNIT	STATE OF THE EVAPORATOR	TEMPERATURE OF THE COMPRESSOR	REMARKS
LEAKAGE	PARTIAL LEAKAGE	Freezer compartment and Refrigerator don't cool normally.	Low flowing sound of Refrigerant is heard and frost forms in inlet only.	A little higher than ambient temperature.	<ul style="list-style-type: none"> Refrigerant level is low due to a leak. Normal cooling is possible by restoring the normal amount of refrigerant and repairing the leak.
	COMPLETE LEAKAGE	Freezer compartment and Refrigerator don't cool normally.	Flowing sound of refrigerant is not heard and frost isn't formed.	Equal to ambient temperature.	<ul style="list-style-type: none"> No discharging of Refrigerant. Normal cooling is possible by restoring the normal amount of refrigerant and repairing the leak.
CLOGGED BY DUST	PARTIAL CLOG	Freezer compartment and Refrigerator don't cool normally.	Flowing sound of refrigerant is heard and frost forms in inlet only.	A little higher than ambient temperature.	<ul style="list-style-type: none"> Normal discharging of the refrigerant. The capillary tube is faulty.
	WHOLE CLOG	Freezer compartment and Refrigerator don't cool.	Flowing sound of refrigerant is not heard and frost isn't formed.	Equal to ambient temperature.	<ul style="list-style-type: none"> Normal discharging of the Refrigerant.
MOISTURE CLOG		Cooling operation stops periodically.	Flowing sound of refrigerant is not heard and frost melts.	Lower than ambient temperature.	<ul style="list-style-type: none"> Cooling operation restarts when heating the inlet of the capillary tube.
DEFECTIVE COMPRESSION	COMP-RESSION	Freezer and Refrigerator don't cool.	Low flowing sound of refrigerant is heard and frost forms in inlet only.	A little higher ambient temperature.	<ul style="list-style-type: none"> Low pressure at high side of compressor due to low refrigerant level.
	NO COMP-RESSION	No compressing operation.	Flowing sound of refrigerant is not heard and there is no frost.	Equal to ambient temperature.	<ul style="list-style-type: none"> No pressure in the high pressure part of the compressor.

Leakage Detection

Observe the discharging point of the refrigerant, which may be in the oil discharging part of the compressor and in a hole in the evaporator.

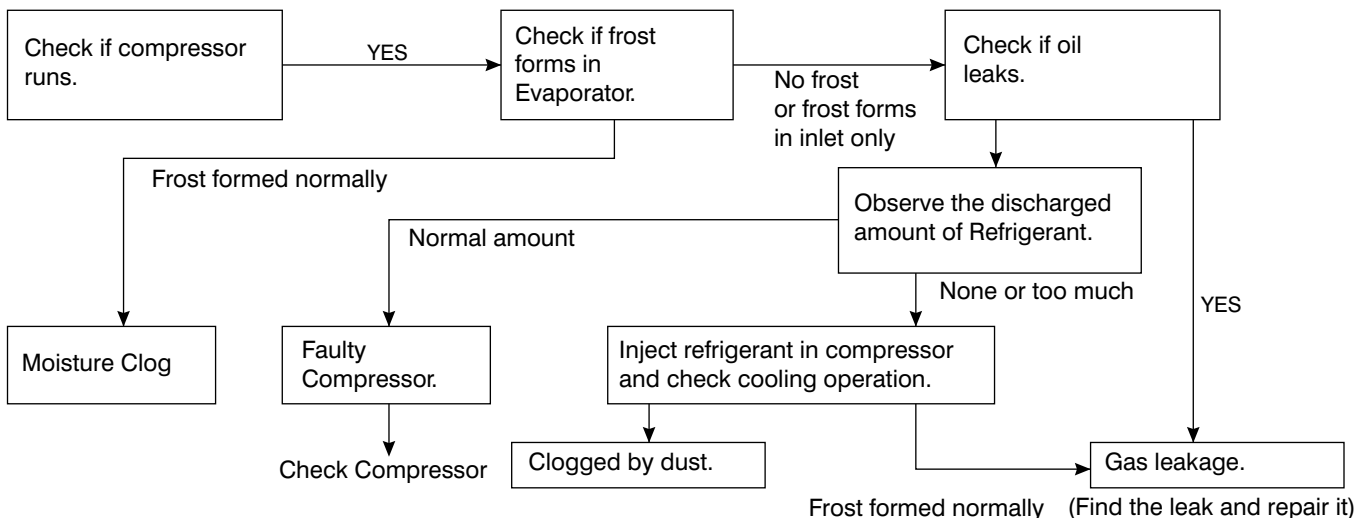

7. DESCRIPTION OF FUNCTION & CIRCUIT OF MICOM

7-1 FUNCTION

7-1-1 Function

1. When the appliance is plugged in, it is set to 37°F for the Refrigerator and 0 °F for the Freezer.
You can adjust the Refrigerator and the Freezer control temperature by pressing the COLDER button or the WARMER button.
2. When the power is initially applied or restored after a power failure, it is set to the setting temperature as you set before power off. (applied to DISPENSER MODEL)

BEST MODEL



7-1-2 How to Change the Temperature Mode to °F / °C

1. The setting temperature mode can be changed to °F / °C by pressing and holding COLDER key of Freezer and COLDER key of Refrigerator over 1 second. at the same time.
2. The initial setting is °F. Whenever the mode is changed, the LED lights are changed.

7-1-4 CONTROL OF FREEZER FAN MOTOR

1. Freezer fan motor has high and standard speeds.
2. High speed is used at power-up, for Ice Plus, and when refrigerator is overloaded.
Standard speeds is used for general purposes.
3. To improve cooling speed, the RPM of the freezer fan motor change from normal speed to high.
4. High speed (2700RPM) : Initial power on or load corresponding operation, Ice Plus.
Normal speed (2400RPM) : General working conditions.
5. Fan motor stops when refrigerator or freezer door opens.

7-1-5 ICE PLUS

1. The purpose of this function is to intensify the cooling speed of freezer and to increase the amount of ice.
2. Whenever selection switch is pressed, selection/release, the LED will turn ON or OFF.
3. If there is a power cutage and the refrigerator is power on again, ICE PLUS function will be canceled.
4. To activate these function, to press the ICE PLUS key and the LED will turn ON. This function will remain activated for 24 hrs. The first three hours the compressor and Freezer Fan will be ON. The next 21 hours the freezer will be controlled at the lowest temperature. After 24 hours or if the ICE PLUS key is pressed again, the freezer will return to its previous temperature.
5. For the first three hours notice the following cases:
 - (1) Compressor and freezer fan (HIGH RPM) continuously operate for three hours.
 - (2) If defrost starts during ICE PLUS, ICE PLUS operates for the rest of time after defrost is completed, when ICE PLUS operation time is less than 90 minutes.
If ICE PLUS operates for more than 90 minutes, the ICE PLUS will operate for two hours after defrost is completed.
 - (3) If ICE PLUS is pressed during defrost, ICE PLUS is on but this function will start seven minutes after defrost is completed and it shall operate for three hours.
 - (4) If ICE PLUS is selected with in seven minutes after compressor has stopped, the compressor (compressor delays seven minutes) shall start after the balance of the delay time.
 - (5) The fan motor in the freezer compartment runs at high speed during ICE PLUS .
6. For the rest of the 21 hours, the freezer will be controlled at the lowest temperature.

7-1-6 REFRIGERATOR LAMP AUTO OFF

1. To avoid heat damage caused by the lamp, it is turned off automatically when the refrigerator door is open for more than 7 minutes.

7-1-7 Alarm for Open Door

1. This feature sounds a buzzer when the freezer or refrigerator door is not closed within 1 minute after it is opened.
2. One minute after the door is opened, the buzzer sounds three times each for 1/2 seconds. These tones repeat every 30 seconds.
3. The alarm is cancelled when the freezer or the refrigerator is closed while the buzzer sounds.

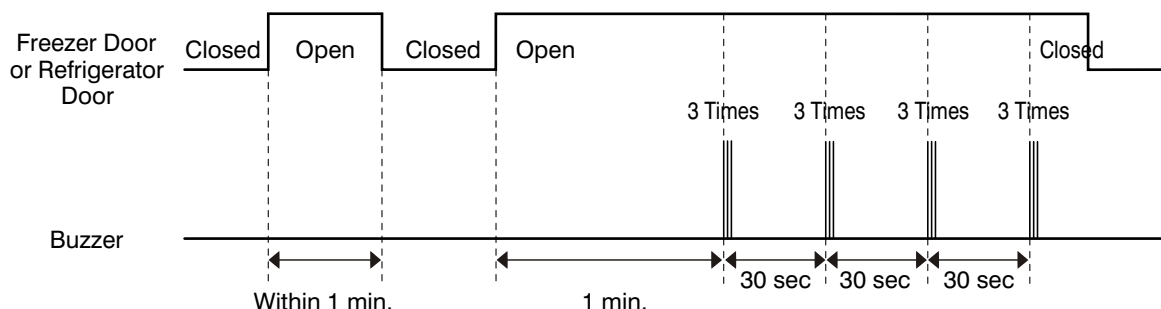

7-1-8 Buzzer Sound

When the button on the front Display is pushed, a Ding~ Dong~ sound is produced.
(Refer to the Buzzer Circuit 8-2-4 No. 3)

7-1-9 Defrosting (removing frost)

1. Defrosting starts each time the COMPRESSOR running time reaches 7 hours.
2. For initial power on or for restoring power, defrosting starts when the compressor running time reaches 4 hours.
3. Defrosting stops if the sensor temperature reaches 46.4°F(8° C) or more. If the sensor doesn't reach 46.4°F(8° C) in 2 hours, the defrost mode is malfunctioning. (Refer to the defect diagnosis function, 8-1-13.)
4. Defrosting won't function if its sensor is defective (wires are cut or short circuited)

7-1-10 Filter Replacement Indication

1. In 6 months after the UNIT (refrigerator) is power on, or after 28,000 seconds of dispenser use, the water filter Indicator LED (red color) will be ON.
2. When the water filter indicator LED is illuminated, you should change the water filter. After this, you must press the water filter button for three seconds and you will hear a ding-dong sound.
The LED will be OFF. This operation will indicate that the UNIT is reset to its initial conditions, so this process is restarted.

7-1-11 Power Failure Compensation Function

1. When the UNIT is power off, the Fresh Food and Freezer Temperature notches, the filter elapsed time for replacement, the temperature mode (°C or °F) and the dispenser lock mode are saved in the EEPROM.
2. When the UNIT is power on, the MICOM will read the specified EEPROM addresses to restore the values indicated in the previous paragraph.

7-1-12 Electrical Parts Are Turned On Sequentially

Electrical parts such as COMP, defrosting heater, freezer FAN, etc. are turned on in the following order to prevent noise and parts damage. Several parts are started at the same time at initial power on and are turned off together when TEST is completed.

OPERATING		ORDERS				
Initial power on	Temperature of Defrosting Sensor is 113°F(45°C) or more (when unit is newly purchased or when moved)	POWER ON	in 1/2 second →	COMP ON	in 1/2 second →	Freezer FAN ON
	Temperature of defrosting sensor is lower than 113°F(45°C) (when power cuts, SERVICE)	POWER ON	in 1/2 second →	Defrosting heater ON	in 10 second →	Defrosting heater OFF
		in 1/2 second →	COMP ON	in 1/2 second →	Freezer FAN ON	
Reset to normal operation from TEST MODE		Total load OFF	in 7 minute →	COMP ON	in 1/2 second →	Freezer FAN ON

7-1-13 Defect Diagnosis Function

1. Automatic diagnosis makes servicing the refrigerator easy.
2. When a defect occurs, the buttons will not operate; but the tones. such as ding. will sound.
3. When the defect CODE removes the sign, it returns to normal operation (RESET).
4. The defect CODE shows on the Refrigerator and Freezer Display.

BEST MODEL



ERROR CODE on display panel

NO	ITEM	ERROR CODE		CONTENTS	REMARKS
		Er	FS		
1	Failure of freezer sensor	Er	FS	Cut or short circuit wire	Inspect Connecting wires on each sensor
2	Failure of Refrigerator sensor	Er	rS	Cut or short circuit wire	
3	Failure of defrost sensor	Er	dS	Cut or short circuit wire	
4	Failure of defrost mode	Er	dH	When defrost sensor doesn't reach 8 °C within 2 hours after starting defrost.	Snapping of defrost heater or Temperature fuse, pull-out of Connector (indicated minimum 2 Hours after failure occurs)
5	Failure of BLDC FAN MOTOR at freezing compartment.	Er	FF	If there is no fan motor signal For more than 65sec. in Operation fan motor	Poor motor, hooking to Wires of fan, contact of structures to fan, snapping or short circuit of Lead wire

7-1-14 TEST Mode

1. The Test mode allows checking the PCB and the function of the product as well as finding out the defective part in case of an error.
2. The test mode is operated by pressing two buttons at Display panel.
3. While in the test mode, the function control button is not recognized, but the recognition tone (beep~) sounds.
4. After exiting the test mode, be sure to reset by unplugging and then plugging in the appliance.
5. If an error, such as a sensor failure, is detected while in the test mode, the test mode is cleared and the error code is displayed.
6. While an error code is displayed, the test mode will not be activated.

MODE	MANIPULATION	CONTENTS	REMARKS
TEST1	Push ICE PLUS key and COLDER KEY of Freezer Temp. at the same time over 3 seconds.	1. Continuous operation of the COMPRESSOR 2. Continuous operation of the freezer fan 3. STEPPING DAMPER OPEN 4. Defrosting Heater OFF 5. Every DISPLAY LED ON	
TEST2	Push ICE PLUS key and COLDER KEY of Freezer Temp. at the same time over 3 seconds in TEST MODE 1	1. COMP OFF 2. Freezer FAN OFF 3. STEPPING DAMPER CLOSE 4. Defrosting heater ON 5. DISPLAY LED shows 222	Reset if the temperature of the Defrosting sensor is 46°F(8°C) or more.
Reset	Push ICE PLUS key and COLDER KEY of Freezer Temp. at the same time over 3 seconds. in TEST MODE 2	Reset to the previously setting before TEST MODE	The compressor will Start after a 7-minute delay.

NOTE : LED CHECK MODE: When the WARMER button in the refrigerator temperature control and the WARMER button in the freezer temperature control are pushed and held for 1 second or longer, every LED on the display turns on at the same time. When the buttons are released, the previous mode is restored.

* Freezer Fan RPM Variable Check:

In case the freezer fan is in operation when the WARMER KEY in Refrigerator and Freezer Temp. Control are pressed for more than one second at the same time freezer fan RPM changes. (for example if high speed, to normal speed or if normal speed, to high speed for 30 seconds)
 After 30 seconds, it turns to its original RPM.

* Demonstration MODE:

1. When the WARMER KEY of refrigerator Temp. control or of freezer Temp. control in the the warmest temperature status are pushed and held for 3 seconds or longer, It converts to Demonstration Mode.
2. It shows OFF on the display panel.
3. In this status, all Loads are off (Compressor / Fan / Damper / Heater)
 (Even is Demonstration Mode, the refrigerator Lamp automatic off function works normally and can be demonstrated)
4. Exit the test mode and reset the display by pressing any warmer button during 3 second.

7-2 PCB FUNCTION

7-2-1 Power Circuit

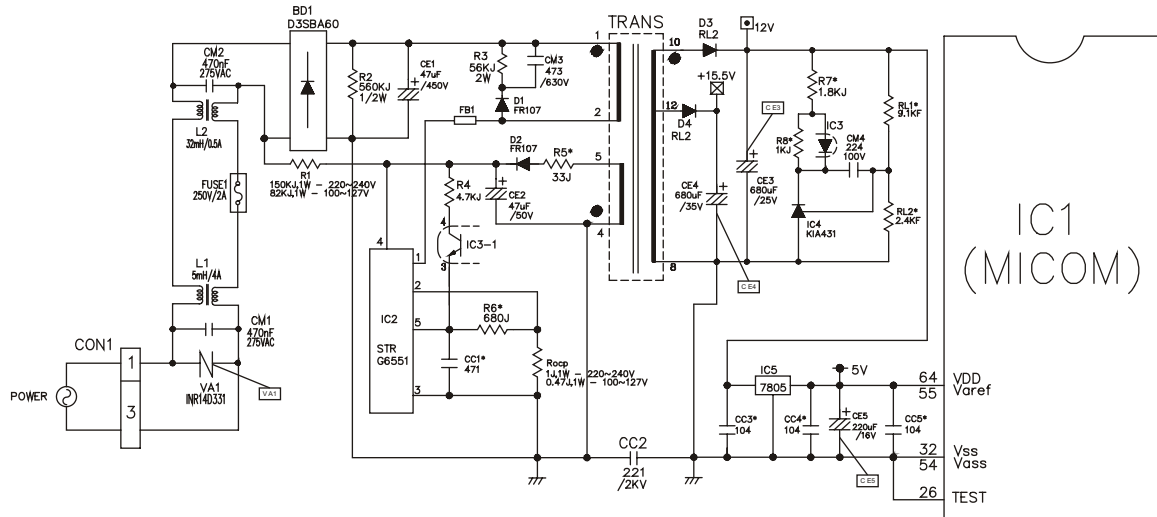

The secondary part of the TRANSFORMER is composed of the power supply for the display, the BLDC FAN Motor drive (15.5 V), the relay drive (12 Vdc) and the MICOM and IC (5 Vdc).

The voltage for each part is as follows:

PART	VA 1	CE 3	CE 4	CE 5
VOLTAGE	115 Vac	12 Vdc	15.5 Vdc	5 V

VA1 is a part for preventing over voltage and noise. When 385V or higher power is applied, the inside elements are short-circuited and broken, resulting in blowout of the fuse in order to protect the elements of the secondary part of the TRANSFORMER.

7-2-2 Oscillation Circuit

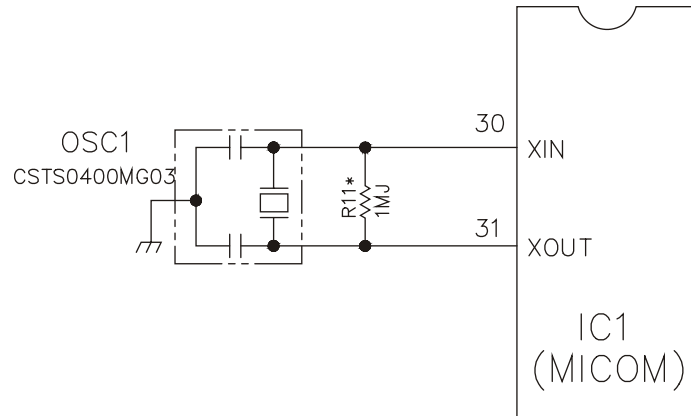

This circuit generates the base clock for calculating time and the synchro clock for transmitting data from and to the inside logic elements of the IC1 (MICOM). Be sure to use specific replacement parts, since calculating time by the IC1 may be changed. If changed, the OSC1 SPEC will not work.

7-2-3 Reset Circuit

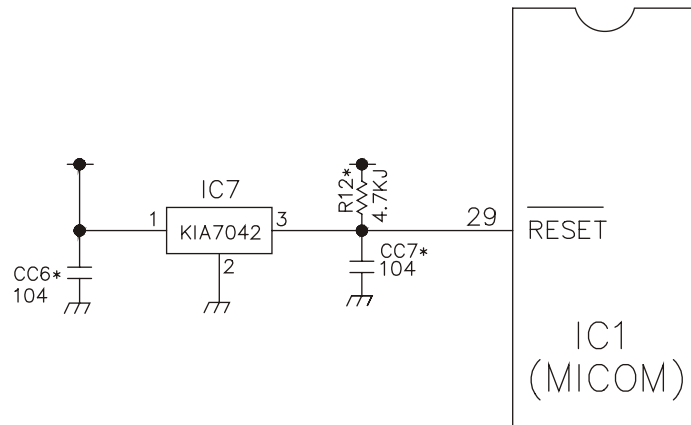

The RESET circuit allows all the functions to start at the initial conditions by initializing various parts, including the RAM inside the MICOM (IC1) when the power is initially supplied or the power supply to the MICOM is restored after a momentary power failure. For the initial 10ms of power supply, LOW voltage is applied to the MICOM RESET terminal. During a normal operation, 5V is applied to the RESET terminal. (If a malfunction occurs in the RESET IC, the MICOM will not operate.)

7-2-4 Load / Buzzer Drive & Open Door Detection Circuit

1. Load Drive Condition Check

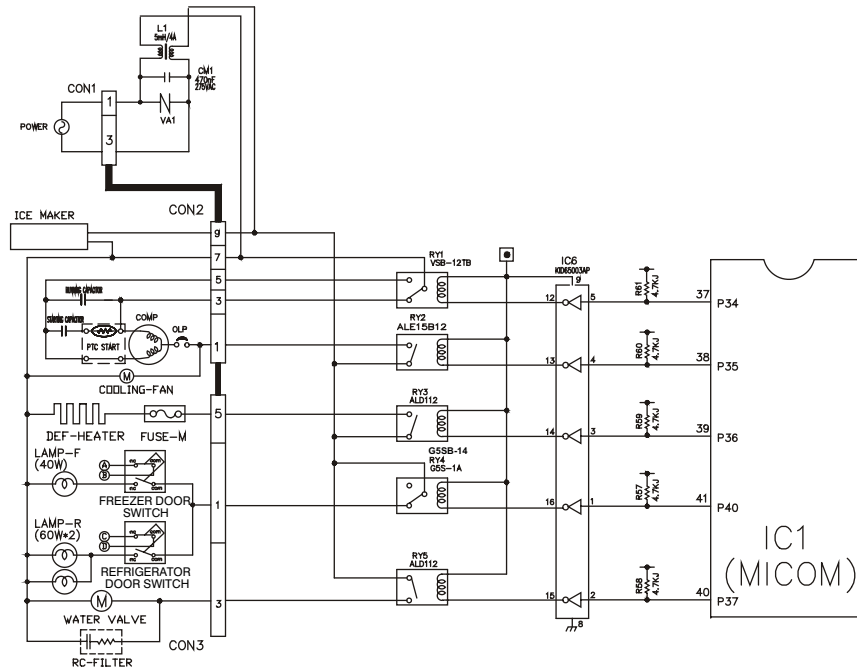

LOAD TYPE		COMP	DEFROSTING HEATER	LAMP	TCM POWER MODE (OPTIONAL)	VALVE (DISPENSER MDL)
Measurement Location (IC6)		NO.13	NO.14	NO.16	NO.12	NO.15
Condition	ON	1V or below				
	OFF	12V				

2. Fan motor driving circuit (freezing compartment fan)

1. This is a circuit to perform a temporary change of speed for the fan motor and applies DC voltage up to 7.5V ~ 16V to motor.
2. This circuit prevents over-driving the fan motor by cutting off power applied to the fan motor in the lock of fan motor by sensing the operation RPM of the fan motor.

	Ⓐ part	Ⓑ part	Ⓒ part
MOTOR OFF	2V or less	0V	5V
MOTOR ON	13V~15V	0V	2V~3V

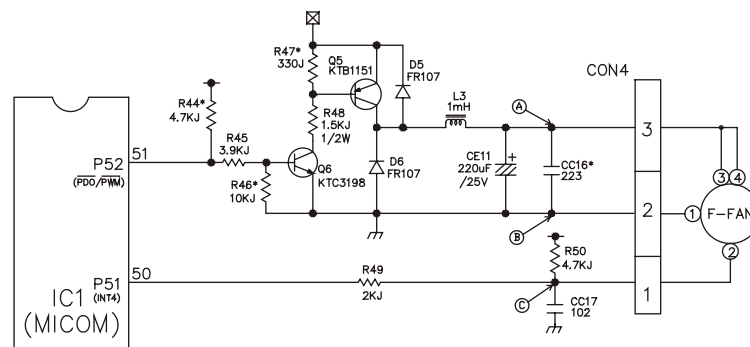

3. Buzzer Drive Condition Check

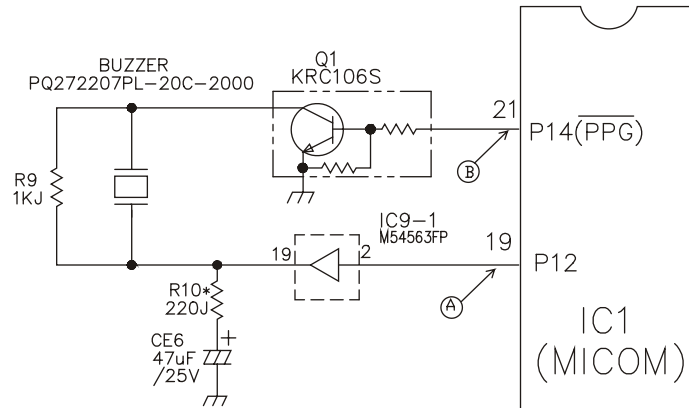

Condition Measurement Location	Tone (Ding~Dong~) when the button on the display is pushed.	Alarm for open door (beep-beep-beep)	OFF
IC1 (A)			0 V
IC1 (B)			0 V

4. Open Door Detection Circuit Check

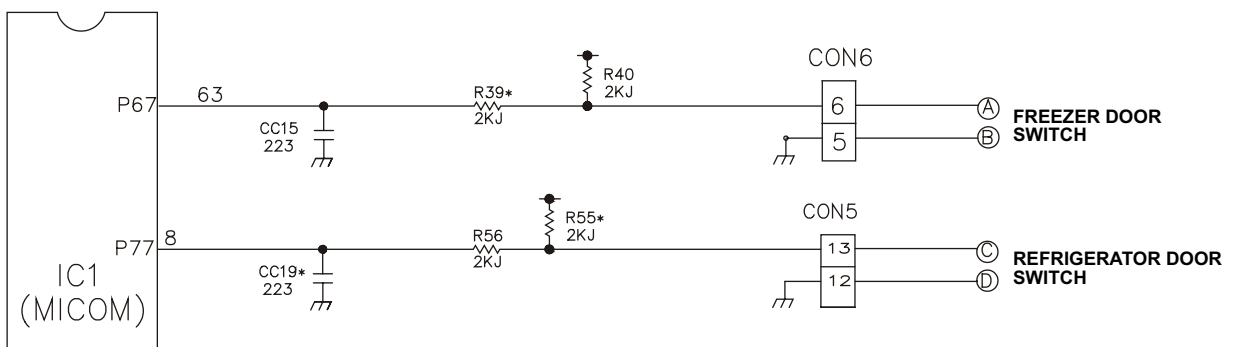

Measurement Location Freezer/ Refrigerator Door	(PIN NO.63 & PIN NO.8)
Closed	5 V
Open	0 V

7-2-5 Temperature Sensor Circuit

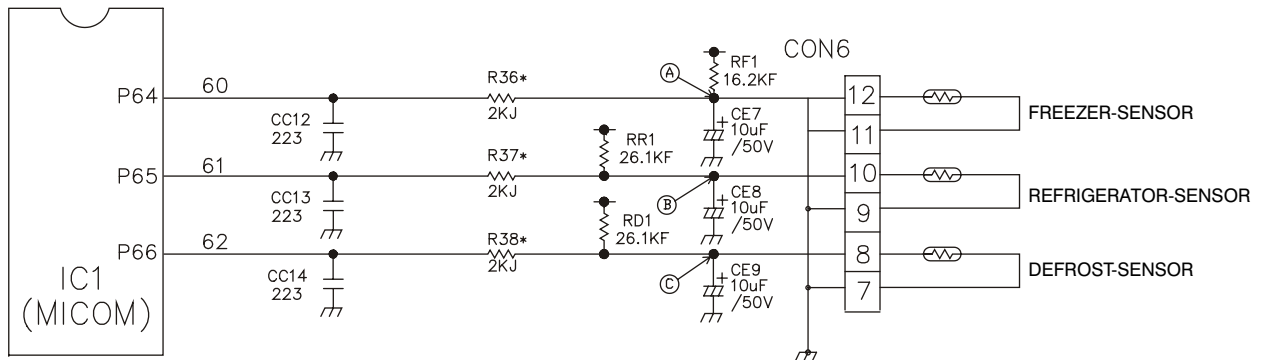

The upper CIRCUIT reads REFRIGERATOR temperature, FREEZER Temperature, and DEFROST-SENSOR temperature for defrosting and the indoor temperature for compensating for the surrounding temperature into MICOM. OPENING or SHORT state of each TEMPERATURE SENSOR are as follows:

SENSOR	CHECK POINT	NORMAL (-30°C ~ 50°C)	SHORT-CIRCUITED	OPEN
Freezer Sensor	POINT (A) Voltage	0.5 V ~ 4.5 V	0 V	5 V
Refrigerator Sensor	POINT (B) Voltage			
Defrosting Sensor	POINT (C) Voltage			

7-2-6 Refrigeration Compartment Stepping Motor Damper Circuit

* The circuit shown below is the damper circuit to regulate the refrigerator temperature.

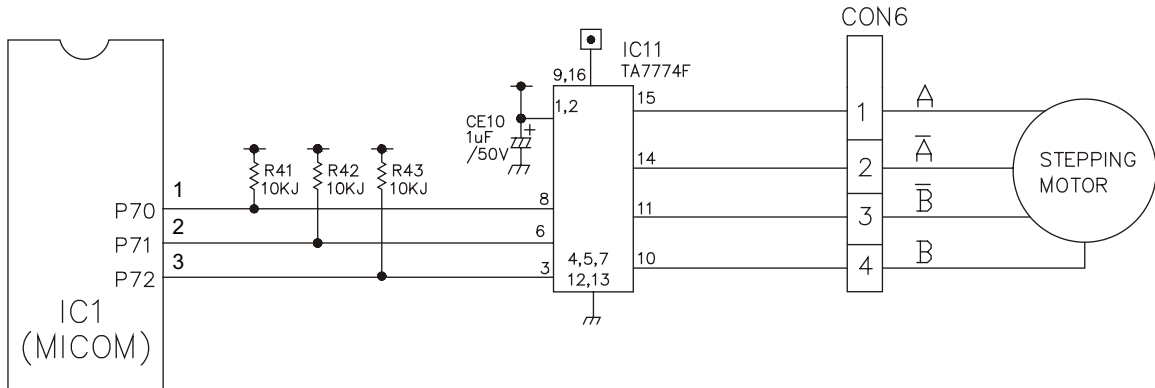

7-2-7 Dispenser Input/LED Output Circuit

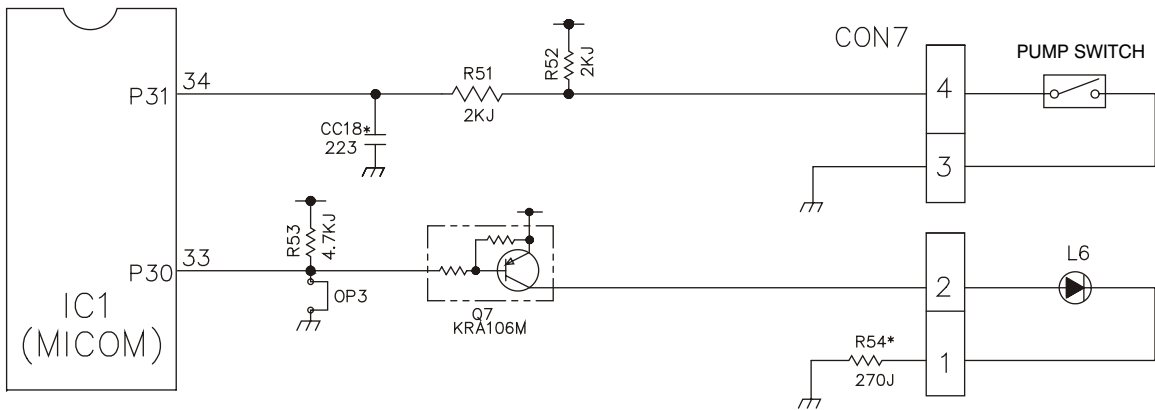

7-2-8 Temperature Compensation & Overcooling/Undercooling Compensation Circuit

1. Refrigerator Temperature Compensation

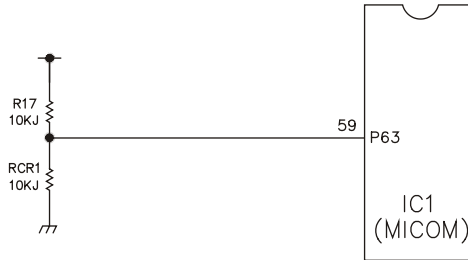

Refrigerator		Remark
Resistance (RCR)	Temperature Compensation	
180 K	+2.5°C	Compensation by raising the temperature ↑
56 K	+2.0°C	
33 K	+1.5°C	
18 K	+1.0°C	
12 K	+0.5°C	
10 K	0 °C	Standard Temperature
8.2 K	-0.5°C	Compensation by lowering the temperature ↓
5.6 K	-1.0°C	
3.3 K	-1.5°C	
2 K	-2.0°C	
470	-2.5°C	

□ Table of Temperature Compensation by adjusting the resistance (difference from the current temperature) e.g., If the refrigerator compensation resistance (RCR) is changed from 10K (the current resistance) to 18K (the adjustment resistance), the temperature of the refrigerator rises 33.8iF(+1iC).

2. The temperature compensation for refrigerator compartment is in the following table:

	Revised resistance	470	2k	3.3k	5.6k	8.2k	10k	12k	18k	33k	56k	180k
	Present resistance											
Refrigerator (RCR)	470	No change	0.5°C Up	1°C Up	1.5°C Up	2°C Up	2.5°C Up	3°C Up	3.5°C Up	4°C Up	4.5°C Up	5°C Up
	2k	0.5°C Down	No Change	0.5°C Up	1°C Up	1.5°C Up	2°C Up	2.5°C Up	3°C Up	3.5°C Up	4°C Up	4.5°C Up
	3.3k	1°C Down	0.5°C Down	No Change	0.5°C Up	1°C Up	1.5°C Up	2°C Up	2.5°C Up	3°C Up	3.5°C Up	4°C Up
	5.6k	1.5°C Down	1°C Down	0.5°C Down	No Change	0.5°C Up	1°C Up	1.5°C Up	2°C Up	2.5°C Up	3°C Up	3.5°C Up
	8.2k	2°C Down	1.5°C Down	1°C Down	0.5°C Down	No Change	0.5°C Up	1°C Up	1.5°C Up	2°C Up	2.5°C Up	3°C Up
	10k	2.5°C Down	2°C Down	1.5°C Down	1°C Down	0.5°C Down	No Change	0.5°C Up	1°C Up	1.5°C Up	2°C Up	2.5°C Up
	12k	3°C Down	2.5°C Down	2°C Down	1.5°C Down	1°C Down	0.5°C Down	No Change	0.5°C Up	1°C Up	1.5°C Up	2°C Up
	18k	3.5°C Down	3°C Down	2.5°C Down	2°C Down	1.5°C Down	1°C Down	0.5°C Down	No Change	0.5°C Up	1°C Up	1.5°C Up
	33k	4°C Down	3.5°C Down	3°C Down	2.5°C Down	2°C Down	1.5°C Down	1°C Down	0.5°C Down	No Change	0.5°C Up	1°C Up
	56k	4.5°C Down	4°C Down	3.5°C Down	3°C Down	2.5°C Down	2°C Down	1.5°C Down	1°C Down	0.5°C Down	No Change	0.5°C Up
180k	5°C Down	4.5°C Down	4°C Down	3.5°C Down	3°C Down	2.5°C Down	2°C Down	1.5°C Down	1°C Down	0.5°C Down	No Change	

NOTE: This circuit is designed to input the necessary temperature compensation values into the MICOM. This adjusts the refrigerator temperature, which is different in each model.

7-2-9 Key Button Input & Display Light-On Circuit

The circuit shown below determines whether a function control key on the operation display is pushed. It also turns on the corresponding function indication LED (LED Module) SEVEN SEGMENT DISPLAY (SEVEN SEGMENT DISPLAY MODULE). The drive type is the scan type

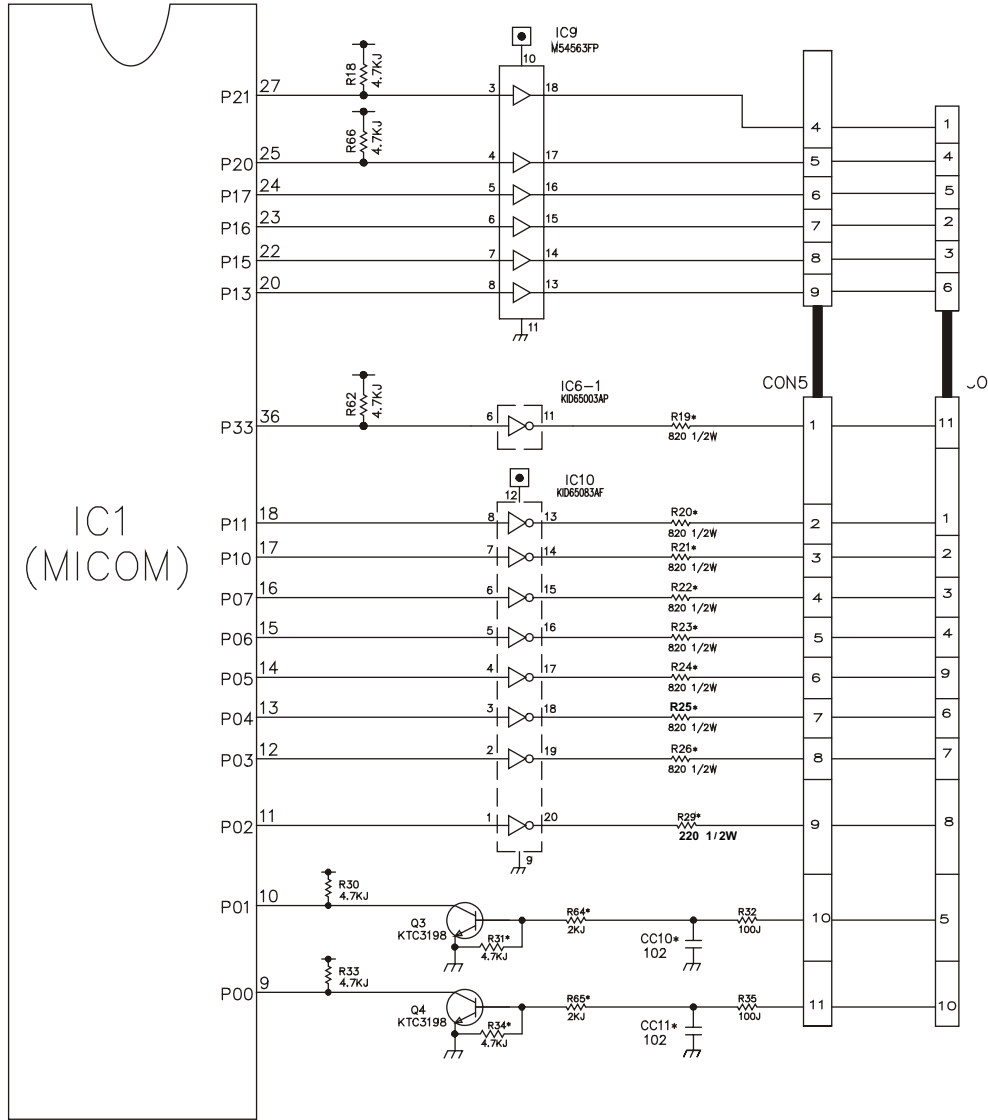

7-2-10 EEPROM CIRCUIT (DISPENSER MODEL)

The purpose of this circuit is to save the current temperature control and the water filter operation time to avoid losing it in case of power failure.

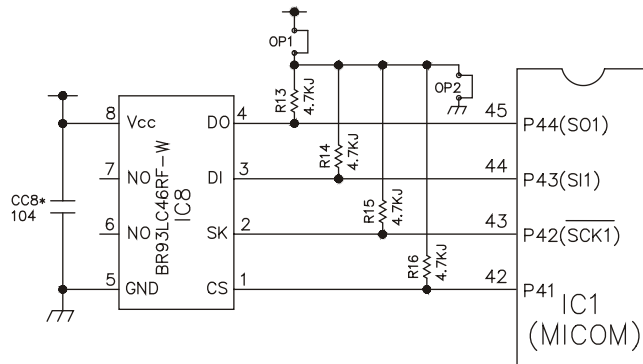

7-3 RESISTANCE SPECIFICATION OF SENSOR

TEMPERATURE DETECTED BY SENSOR	RESISTANCE OF FREEZER SENSOR	RESISTANCE OF REFRIGERATOR & DEFROST SENSOR & ROOM SENSOR
- 20°C	22.3 K	77 K
- 15°C	16.9 K	60 K
- 10°C	13.0 K	47.3 K
- 5°C	10.1 K	38.4 K
0°C	7.8 K	30 K
+ 5°C	6.2 K	24.1 K
+ 10°C	4.9 K	19.5 K
+ 15°C	3.9 K	15.9 K
+ 20°C	3.1 K	13 K
+ 25°C	2.5 K	11 K
+ 30°C	2.0 K	8.9 K
+ 40°C	1.4 K	6.2 K
+ 50°C	0.8 K	4.3 K

The resistance of the SENSOR has a $\pm 5\%$ common difference.

Measure the resistance of the SENSOR after leaving it for over 3 minutes in the measuring temperature.

This delay is necessary due to sensor response speed.

7-4 TROUBLESHOOTING

PROBLEM	INDICATED BY	CHECK	CHECKING METHOD	CAUSE	SOLUTION
POWER SOURCE is poor.	1. The whole DISPLAY LED/SEVEN SEGMENT DISPLAY is off. 2. DISPLAY LED/SEVEN SEGMENT DISPLAY operates abnormally	1. FREEZER/REFRIGERATOR.	Check if FREEZER/REFRIGERATOR DOOR IS OPEN and check display.	POWER SOURCE is poor.	Check outlet Voltage.
		2. If LAMP is dim.	Check visually.	Applied voltage error.	Use boosting TRANS.
		3. The connection of the MAIN PWB CONNECTOR.	Check connection of CONNECTOR.	CONNECTOR connection is poor. TRANS FUSE is open.	Reconnect CONNECTOR. Replace TRANS.
COOLING is poor.	NO COOLING.	1. If the COMPRESSOR operate.	USE TEST MODE1 (forced COOLING). If less than 7 minutes pass after compressor shuts off, don't press the KEY and wait.	COMPRESSOR locked or blocked. OLP, PTC is poor. COMPRESSOR RELAY is poor. THE CONNECTING WIRE is poor.	Replace COMPRESSOR. Replace OLP, PTC. Replace MAIN PWB. Check the connection of the black wire of the MAIN PWB CONNECTOR (CON2).
FREEZER TEMPERATURE is incorrect		2. If refrigerant is leaking.	Measure the amount of frost sticking on EVAPORATOR and the surface temperature of the condenser pipe.	Refrigerant leakage	Replace the leaking part and replace any lost refrigerant.
		1. If FAN MOTOR operates.	USE TEST MODE1 (forced COOLING).	FAN MOTOR is poor	Replace the FAN MOTOR.
		2. If DEFROSTING is normal.	Check the amount of frost sticking on the APORATOR.	DEFROSTING is poor.	See DEFROSTING is poor.
		3. If SENSOR is normal.	Check the resistance of the Refrigerator SENSOR.	SENSOR RESISTANCE is poor.	Replace SENSOR.
		4. Door Line contact.	Check the seal when the door is closed.	Door liner damaged.	Replace door liner.

PROBLEM	INDICATED BY	CHECK	CHECKING METHOD	CAUSE	SOLUTION
COOLING is poor.	If REFRIGERATOR TEMPERATURE is too low.	1. If FREEZER TEMPERATURE is normal.	Check if FREEZER TEMPERATURE is too low.	FAN MOTOR is poor.	Make sure the DOOR is attached. Replace FAN MOTOR.
		2. If amount of cool air from FAN MOTOR is sufficient.	Make sure that the amount and speed of cool air are sufficient by touching the check supplied on the REFRIGERATOR.	Passage of cool air is blocked. EVA frozen.	Remove impurities. See DEFROSTING is poor .
		3. Door Line contact:	Check door seal when door is closed.	Door liner damaged.	Replace Door liner.
DEFROSTING is poor.	NO DEFROSTING.	1. If HEATER emits heat.	USE TEST MODE2 (forced DEFROSTING).	HEATER disconnection.	Replace HEATER.
				TEMPERATURE FUSE disconnection.	Replace TEMPERATURE FUSE.
				Connection is poor.	Check EVAPORATOR connection and wire of MAIN PWB CONNECTOR.
				DEFROST-SENSOR is poor.	Replace DEFROST-SENSOR.
				HEATER RELAY is poor.	Replace RY3 of MAIN PWB.
				DRAIN PIPE is blocked.	Remove ice and impurities. Check HEATER PLATE resistance.
		2. If DRAIN PIPE is blocked.	Check DRAIN PIPE.	Connection is poor.	Reassemble the DEFROST-SENSOR.
				Make sure that DEFROST SENSOR is connected.	Reassemble DOOR.
				Make sure that FREEZER / REFRIGERATOR DOOR is closed.	Replace GASKET.
		3. If ice remains after DEFROSTING.		DOOR does not close properly.	

7-5 MAIN PWB ASSEMBLY AND PARTS LIST

7-5-1 Main PWB Assembly

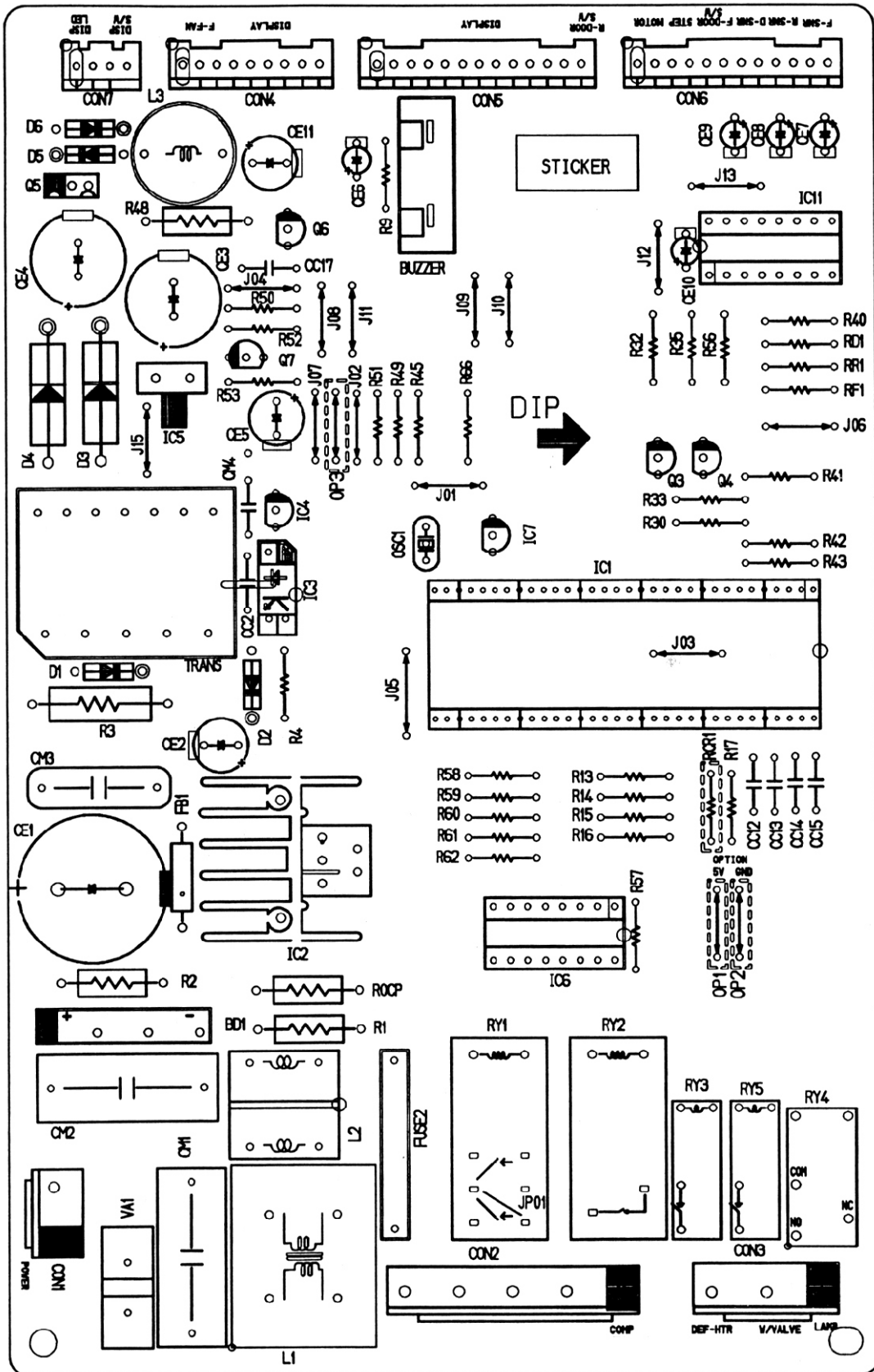

7-5-2 Replacement Parts List

No	P/N/O	DESCRIPTION	SPEC	MAKER	REMARK
1	6670_BB087D	PMB(PCB)	KS-PJT BEST	DOO SAN	T-1,6
2	6170_BB2012A	TRANSFORMER, SMPS COIL 1	KS-PJT 220-240V	SAM IL	TRANS
3	6170_BB2012B	TRANSFORMER, SMPS COIL 1	KS-PJT 100-127V	SAM IL	TRANS
4	6630A09106A	CONNECTOR (ICIRC1), WAFER	YK36-03AV	YEON HO	CON2
5	6630A09106B	CONNECTOR (ICIRC1), WAFER	YK396 YEONHO 9P 3.96MM AV	YEON HO	CON2
6	6630A09106B	CONNECTOR (ICIRC1), WAFER	YK396 YEONHO 9P 3.96MM AV	YEON HO	CON3
7	6630_BB007H	CONNECTOR (ICIRC1), WAFER	917787-1 AMP 9P 2.5MM STRAIGHT SN	AMP	CON4
8	6630_BB007A	CONNECTOR (ICIRC1), WAFER	917791-1 AMP 13PIN 2.5MM STRAIGHT SN	AMP	CON5
9	6630_BB007L	CONNECTOR (ICIRC1), WAFER	917790-1 AMP 12P 2.5MM STRAIGHT SN	AMP	CON6
10	6630_BB007C	CONNECTOR (ICIRC1), WAFER	917782-1 AMP 4P 2.5MM STRAIGHT SN	AMP	CON7
11	01SK665100A	IC, SANKEN	STR-6651 5PIN BK SMPS 2,4PIN FORM	SANKEN	IC2
12	01ZZ_BB2024D	IC, DRAWING	TMF870X40AN 64PIN, SDIP BK KS-PJT MASK 1	TOSHIBA	IC11-01ZZ_BB2024R1
13	-	-	-	-	-
14	01FM6NE001A	IC, TOSHIBA	1TL727F 4P BK PHOTO COUPLER	TOSHIBA	IC3
15	01KE431000A	IC, KEC	K1A43L 3 PIN TP - -	KEC	IC4
16	01KE780500W	IC, KEC	K1A7805P1 - - -	KEC	IC5
17	01KE650830B	IC, KEC	K1D6508AE 2050P LED DRIVER	KEC	IC10
18	01KE650030B	IC, KEC	K1D65003AP 16P SDIP BK DRIVE	KEC	IC6
19	01STLM001A	IC, STANDARD LOGIC	M54563P 20 R/TIP CONVERT	MITSUBISHI	IC9
20	01KE704200A	IC, KEC	K1A7042P 3P BK RESET -	KEC	IC7
21	01U7774400A	IC, TOSHIBA	1A7774AP 16, SDIP BK DRIVE IC STEPPING M	TOSHIBA	IC8
22	01R4934600D	IC, ROHM	R493L 046FF W SPIN SOP BK EEPROM -	ROHM	IC04
23	000000001A	RELAY	AL1E912 MATSUISHITA 12V 16A 15.6V 1A	NAIS	RY2
24	6920AL_Z001A	RELAY	AL212B12 NAIS 250VAC 16A 12VDC IC NO VENTING	NAIS	-
25	6920_BB2005B	RELAY	G58B-14 250VAC 5A 12VDC IC	OMRON	RY4
26	6920_BB2007A	RELAY	V58-121B TAKAMISAWA DC12V 60MA 250V IC	FUJITSU	RY1
27	6920A90002A	RELAY	ALD112 NAIS1TH(I)ALD1 250V-3A 12V 16.6mA 1A	NAIS	RY3
28	6212_BB001B	RESONATOR, CERAMIC	CST50400M03 MURATA 4MHZ TP	MURATA	RY5
29	6102_BB003A	VARIABLE	INR14D271 ILJIN UL/VDE TP 270V	ILJIN	OSC1
30	6102_BB001B	VARIABLE	INR14D261 ILJIN UL/VDE BK 620V	ILJIN	VA1
31	00R1070094A	DIODE, RECTIFIERS	FR107 TP DELTA D041 1000V 1A 3	DELTA	DI_02, D5, D6
32	00RS400070A	DIODE, RECTIFIERS	R1.2 SANKEN BK NON 400V 2A 40A 50NSEC 10UA	SANKEN	D3, D4
33	00B360000AA	DIODE, RECTIFIERS	D3B60 BK SHINDENGEN 600V 4A	SHINDENGEN	BD1
34	6102W5V006A	VARIABLE	INR14D33K ILJIN UL/CSA/VDE BK	ILJIN	VA1
35	0CE476ZVE0	CAPACITOR, FIXED ELECTROLYTIC	47UF HE 450V 20% BULK 9NAP INT1051	SAM WHA	CE1
36	0CE476BK63B	CAPACITOR, FIXED ELECTROLYTIC	47UF KME TYPE 50V 20% FMS TP 5 (11051)	SAM WHA	CE2
37	0CE1076F63B	CAPACITOR, FIXED ELECTROLYTIC	100UF SMS, S6 25V 20% FMS TP 5	SAM WHA	CE12
38	0CE687H4E0	CAPACITOR, FIXED ELECTROLYTIC	680UF RK 250V 20% BULK 9NAP INT1051	SAM WHA	CE3
39	0CE687YJ61B	CAPACITOR, FIXED ELECTROLYTIC	680UF RK 35V 0.2 TP 5 FL11051	SAM WHA	CE4
40	0CE227B6F63B	CAPACITOR, FIXED ELECTROLYTIC	220UF KME TYPE 16V 20% FMS TP 5(11051)	SAM WHA	CE5
41	0CE227B6E3B	CAPACITOR, FIXED ELECTROLYTIC	220UF RS TYPE 25V 20% FMS TP 5(11051)	SAM WHA	CE11
42	0CE105BK63B	CAPACITOR, FIXED ELECTROLYTIC	1UF KME TYPE 50V 20% FMS TP 5(11051)	SAM WHA	CE10
43	0CE476BK63B	CAPACITOR, FIXED ELECTROLYTIC	47UF KME TYPE 25V 20% FMS TP 5(11051)	SAM WHA	CE6
44	0CE106EK63B	CAPACITOR, FIXED ELECTROLYTIC	10UF KMG 50V 20% FMS TP 5(11051)	SAM WHA	CE7-CE9
45	00H471K1562	CAPACITOR, FIXED CERAMIC (HIGH DIELECTRIC)	470PF 50V K X7R1X1 1608 R/TP	MURATA	CC1
46	00X2210R61A	CAPACITOR, FIXED CERAMIC (HIGH DIELECTRIC)	250PF D 250V 10% -10% B1V5P1 R/TP	SAM WHA	CC2
47	00X104K94A	CAPACITOR, FIXED CERAMIC (HIGH DIELECTRIC)	100NF 2012 50V R/TP (GRM40X7R104K50PE)	MURATA	CC3-CC7
48	00X102K959	CAPACITOR, FIXED CERAMIC (HIGH DIELECTRIC)	1000PF 50V K B T AS2	MURATA	CC8
49	00X2230K96A	CAPACITOR, FIXED CERAMIC (HIGH DIELECTRIC)	22NF 2012 50V 80%, -20% R/TP X7R	MURATA	CC16, CC18, CC19
50	00X2230K949	CAPACITOR, FIXED CERAMIC (HIGH DIELECTRIC)	22NF 50V Z F AS2	MURATA	CC12-CC15
51	00X102K96A	CAPACITOR, FIXED CERAMIC (HIGH DIELECTRIC)	1NF 2012 50V 80%, -20% R/TP X7R	MURATA	CC10
52	00C4741B670	CAPACITOR, FIXED FILM	0.47UF D 275V M M/PP NI R	PILKOR	CM1, CM2
53	00F2240B670	CAPACITOR, FIXED FILM	220NF D 275V 20% BULK M/PP NI	PILKOR	-
54	00A473N430	CAPACITOR, FIXED FILM	47000PF S 630V J M/PE NI R	SAM WHA	CM3
55	00C224IN630	CAPACITOR, FIXED FILM	0.22UF D 100V M M/PE NI R	SAM WHA	CM4
56	00C223IN409	CAPACITOR, POLYESTER	0.022UF D 100V J PE TP	SAM WHA	CM5
57	0R_2200H672	RESISTOR, METAL GLAZED (CHIP)	220 OHM 1/2 W 5%, 2012 R/TP	SMART, CHOHYANG	R29
58	0RS1503J609	RESISTOR, FIXED METAL OXIDE FILM	150K OHM 1W 5.00% TA52	SMART, CHOHYANG	R1
59	0RS8202609	RESISTOR, FIXED METAL OXIDE FILM	82K OHM 1W 5.00% TA52	SMART, CHOHYANG	R1
60	0RS010J609	RESISTOR, FIXED METAL OXIDE FILM	1 OHM 1 W 5.00% TA52	SMART, CHOHYANG	ROCP
61	0RS0470J609	RESISTOR, FIXED METAL OXIDE FILM	0.47 OHM 1 W 5% TA52	SMART, CHOHYANG	ROCP
62	0RS5502K641	RESISTOR, FIXED METAL OXIDE FILM	55K OHM 2 W 5.00% TA52	SMART, CHOHYANG	R3
63	0R_8200H672	RESISTOR, METAL GLAZED (CHIP)	820 OHM 1/2 W 5%, 2012 R/TP	SMART, CHOHYANG	R19-R26
64	0RD5016H609	RESISTOR, FIXED CARBON FILM	500K OHM 1/2 W 5.00% TA52	SMART, CHOHYANG	R19
65	0RD1501H609	RESISTOR, FIXED CARBON FILM	1.5K OHM 1/2 W 5.00% TA52	SMART, CHOHYANG	R48
66	0RD1000G609	RESISTOR, FIXED CARBON FILM	100 OHM 1/4 W 5.00% TA52	SMART, CHOHYANG	R32
67	0R_2200L622	RESISTOR, METAL GLAZED (CHIP)	220 OHM 1/8 W 2012 5.00% D	ROHM	R36
68	0RH470L622	RESISTOR, METAL GLAZED (CHIP)	4.7K OHM 1/8 W 2012 5.00% D	ROHM	R10, R12, R44, R31, R18
69	0RH100L622	RESISTOR, METAL GLAZED (CHIP)	10K OHM 1/8 W 2012 5.00% D	ROHM	R34
70	0R_0332E672	RESISTOR, FIXED CARBON FILM	33 OHM 1/8 W 5%, 2012 R/TP	ROHM	R46
71	0RD100IG609	RESISTOR, FIXED CARBON FILM	1K OHM 1/4 W 5.00% TA52	SMART, CHOHYANG	R5
72	0RH100L622	RESISTOR, METAL GLAZED (CHIP)	1K OHM 1/8 W 2012 5.00% D	ROHM	R8
73	0R_2001L622	RESISTOR, METAL GLAZED (CHIP)	2K OHM 1/8 W 2012 5.00% D	ROHM	R55, R64, R36-R39
74	0RD200IG609	RESISTOR, FIXED CARBON FILM	2K OHM 1/4 W 5.00% TA52	SMART, CHOHYANG	R40, R49, R51, R52, R56
75	0R_0330L622	RESISTOR, METAL GLAZED (CHIP)	330 OHM 1/8 W 2012 5.00% D	ROHM	R47
76	0RH100L622	RESISTOR, METAL GLAZED (CHIP)	1M OHM 1/8 W 2012 5.00% D	ROHM	R11
77	0RH622K409	RESISTOR, FIXED CARBON FILM	16.2K OHM 1/4 W 1.00% TA52	SMART, CHOHYANG	RF1
78	0RN2612K409	RESISTOR, FIXED CARBON FILM	26.1K OHM 1/4 W 1.00% TA52	SMART, CHOHYANG	RF1, RF1
79	0RD350IG609	RESISTOR, FIXED CARBON FILM	3.5K OHM 1/4 W 5.00% TA52	SMART, CHOHYANG	R45
80	0RD470IG609	RESISTOR, FIXED CARBON FILM	4.7K OHM 1/4 W 5.00% TA52	SMART, CHOHYANG	R4, R30, R33, R50, R57-R62, R66
81	0R_6800E672	RESISTOR, METAL GLAZED (CHIP)	680 OHM 1/8 W 5%, 2012 R/TP	ROHM	R13-R16, R53
82	0RD1002G609	RESISTOR, FIXED CARBON FILM	10K OHM 1/4 W 5.00% TA52	SMART, CHOHYANG	R6
83	0RH100L622	RESISTOR, METAL GLAZED (CHIP)	1.8K OHM 1/8 W 2012 5.00% D	ROHM	R17, RCR1, R41-R43
84	0RD2702G609	RESISTOR, FIXED CARBON FILM	27K OHM 1/4 W 5.00% TA52	SMART, CHOHYANG	R7
85	0RD4702G609	RESISTOR, FIXED CARBON FILM	47K OHM 1/4 W 5.00% TA52	SMART, CHOHYANG	-
86	0R_910E472	RESISTOR, FIXED METAL FILM	9.1K OHM 1/8 W 1%, 2012 R/TP	ROHM	-
87	0R_240IE472	RESISTOR, FIXED METAL FILM	2.4K OHM 1/8 W 1%, 2012 R/TP	ROHM	RL1
88	0R_2700E672	RESISTOR, METAL GLAZED (CHIP)	270 OHM 1/8 W 2012 5.00% D	ROHM	RL2
89	0TRKE00008A	TRANSISTOR, BIPOLAR	KEC K1B151 BK 10126 60V 5A	KEC	RS4
90	0TRP31909AA	TRANSISTOR	KTC319B-TP-Y (KTC1B151)KEC	KEC	OS_06
91	0TRKE90016A	TRANSISTOR, BIPOLAR	KEC KR1065 R/TP SOT23 50V 100MA	KEC	O1
92	0TR106009AC	TRANSISTOR, BIPOLAR	KRA 106M KEC	KEC	O7
93	-	-	KTC3875 KEC	KEC	-
94	6210_BB001A	SWITCH, TRIP, EMC	BFS3D0AD SAMMHA 52	SAM WHA	FBI
95	6600R1001Z	SWITCH, TACT	J1P123046 JEIL 12V DC 50MA	JEIL	SW1
96	6854B50001A	JUMP WIRE	0.6MM 52MM TP TAPING SNT10MM	DAE A LEAD	J01-J04, J06-J13, J14, JPO1
97	6854B50001A	JUMP WIRE	0.6MM 52MM TP TAPING SNT10,5MM	DAE A LEAD	J05
98	6854B50001A	JUMP WIRE	0.6MM 52MM TP TAPING SNT10MM	DAE A LEAD	OP1
99	6854B50001A	JUMP WIRE	0.6MM 52MM TP TAPING SNT10MM	DAE A LEAD	OP2, OP3, R13-R16
100	6200_BB004A	FILTER (ICIRC1), EMC	CV940050 TNC BK	TNC	L1
101	6200_BB007X	FILTER (ICIRC1), EMC	UV11-05320 TNC BK 0.5A 32MH	TNC	L2
102	0LR000M4F0	INDUCTOR, RADIAL LEAD	1000UH 20% R 5X12.5 BULK	TNC	L3
103	0FR6001E521	FUSE, FAST BLOW	6000MA 250V 6.3X31.8 CY/GL KS	SAM JU	FUSE1
104	6901_BB001A	FUSE ASSEMBLY	KORE-PTJ NVS	SAM JU	FUSE HOLDER
105	0FZ7_BB001A	FUSE, DRAWING	2A 250V SLOW-BLOW LITTLE FUSE, TRIAD	SAM JU	FUSE1
106	6908_BB3002F	BUZZER	06E2228P DAE YOUNG PE20 2W 7550CHNA1	DAE YOUNG	BUZZER
107	4920_BB3007A	HEAT SINK	23.3x17x25 DRIVE IC STR	-	(IC2)
108	158F030241B	SCREW TAP TITE (S), BINDING HE	+03.0 LB. 0 MSWR3/FZY	SHAN	(IC2)
109	9WIF0120000	SOLDER (ROSIN WIRE) R50	DI_20	-	-
110	49H1004	SOLDER, SOLDERING	H63A	HISUNG	-
111	59333105	FLUX	SG101.825 0.830 KOREA F.H-206	KOKI	-
112	00C03H609	CAPACITOR, FIXED FILM	0.01UF D 100V 10% PE 1P5	SAM WHA	CM4

7-5-3 PWB Assembly Display and Parts List

Best Model

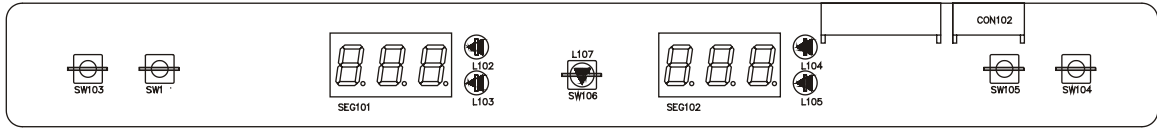

No	P/NO	DESCRIPTION	SPEC	MAKER	REMARK
1	6870JB8090A	PWB(PCB)	KS-PJT DISPENSER DISPLAY	DDO SAN	-
2	-	-	-	-	-
3	6630JB8005D	WAFER	SMAW250-11	YEON HO	CON101
4	6630JB8004U	-	SMAW250-06	-	CON102
5	6600JB8005A	SWITCH,TACT	KPT-1105A	KYUNG IN	SW102~105
6	6600RRT002K	-	JTP1230A JEIL 12V DC 50MA	JEIL	-
7	6600JB8004A	TACT S/W	KPT-1109R	KYUNG IN	SW106
8	-	TACT S/W	KPT-1109G	KYUNG IN	-
9	6327JB8001A	DISPLAY LED ASSEMBLY	LN4023-13EWRS GREEN 2.1V 1.7MCD	LEDTECH	SEG1,SEG2
10	0DLLE0059AA	LED	LT8323-41-BCN 2.1V D3 TP GREEN	-	L102~105
11	0DD414809AA	DIODE,SWITCHING	1N4148 26MM	PYUNG CHANG	D107~113
12	0DD400400A	-	1N4004	DELTA	D101~106
13	6854B50001A	JUMP WIRE	0.6MM 52MM TP TAPING SN<10MM>	-	J01~06,J08~13
14	9VWF0120000	SOLDER<ROSN WIRE> RS0	D1.20	HEE SUNG	-
15	49111004	SOLDER,SOLDERING	H63A	-	-
16	59333105	FLUX	SG;0.825-0.830 KOREA F.H-206	KOKI	-

7-6 PWB DIAGRAM

7-6-1 PWB Main Assembly

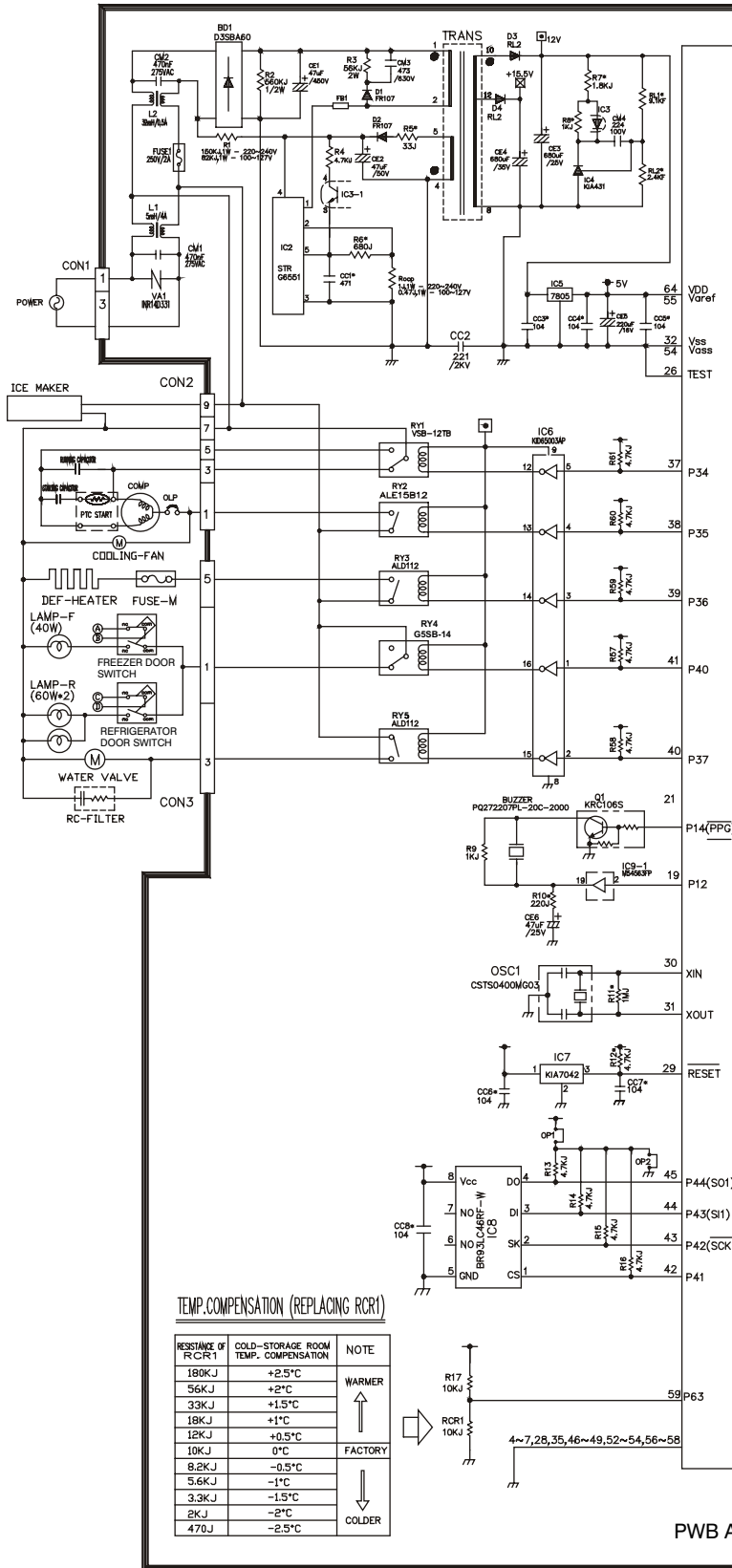

TOSHIBA TMP87C840N(IC1)

TEMP. COMPENSATION (REPLACING RCR1)

RESISTANCE OF RCR1	COLD-STORAGE ROOM TEMP. COMPENSATION	NOTE
180KJ	+2.5°C	WARMER ↑
56KJ	+2°C	
33KJ	+1.5°C	
18KJ	+1°C	
12KJ	+0.5°C	FACTORY
10KJ	0°C	
8.2KJ	-0.5°C	
5.6KJ	-1°C	
3.3KJ	-1.5°C	
2KJ	-2°C	COLDER ↓
470J	-2.5°C	

PWB ASSEMBLY

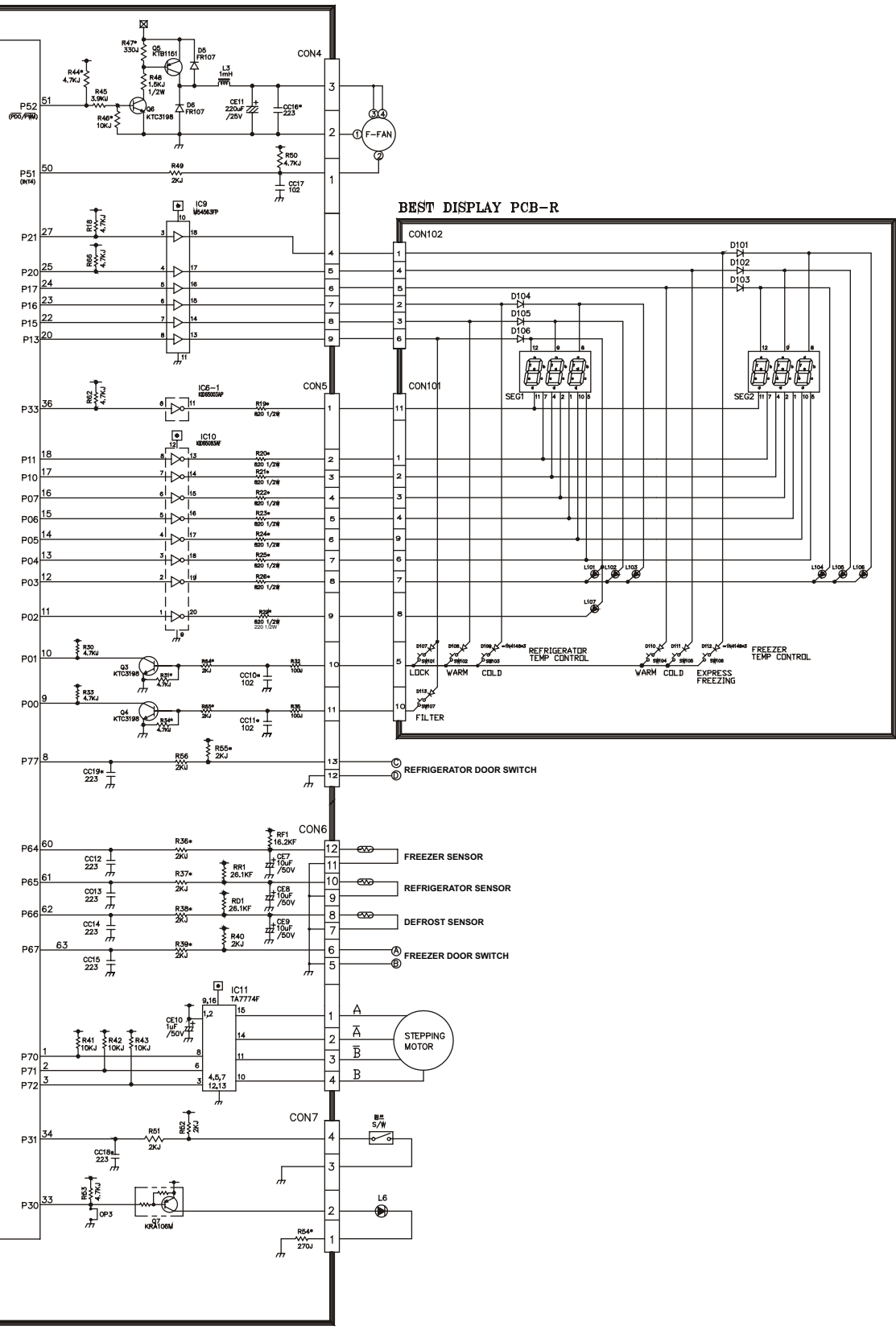

EXPLODED VIEW

CASE PARTS

CAUTION: Use the part number to order part, not the position number.

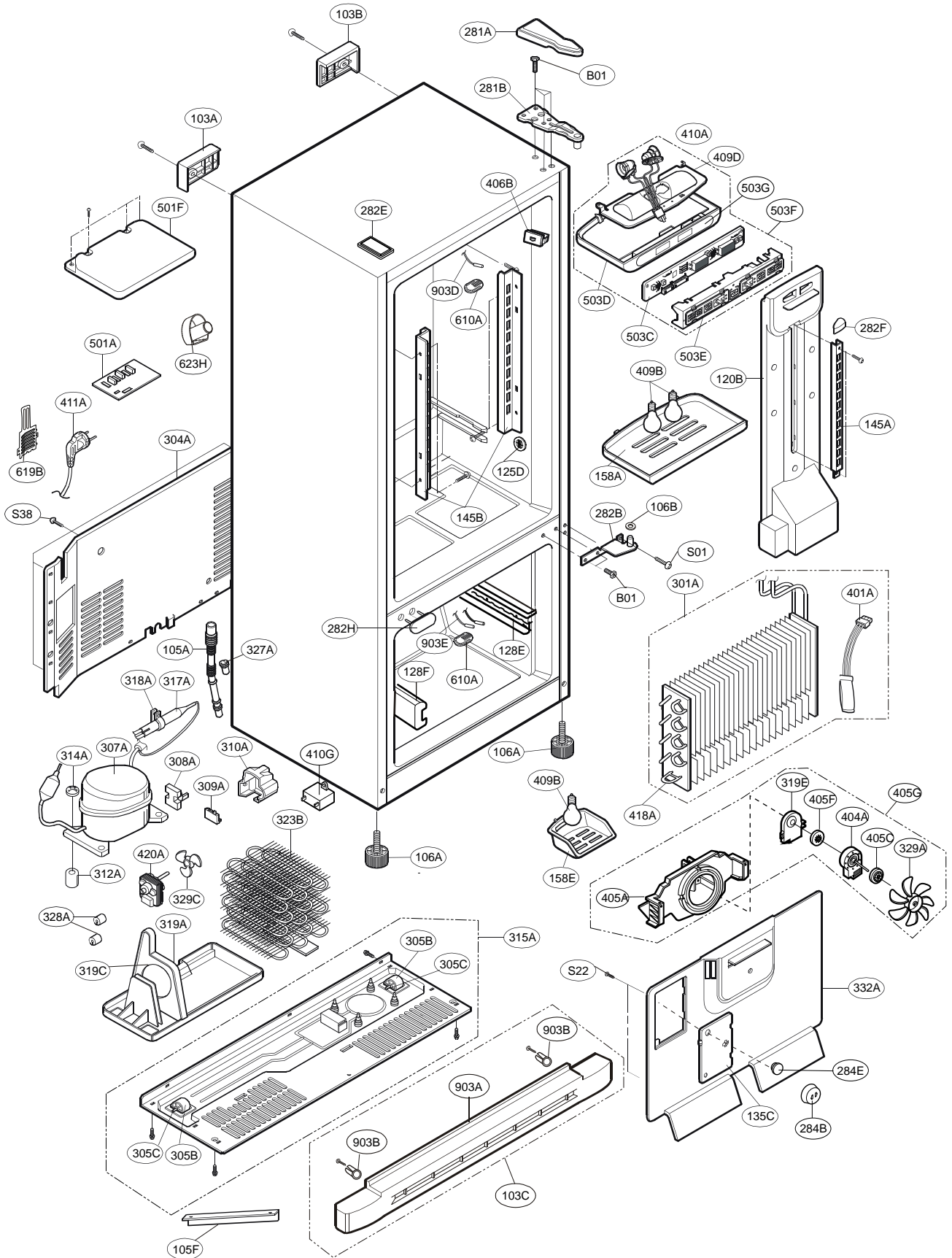

FREEZER PARTS

CAUTION: Use the part number to order part, not the position number.

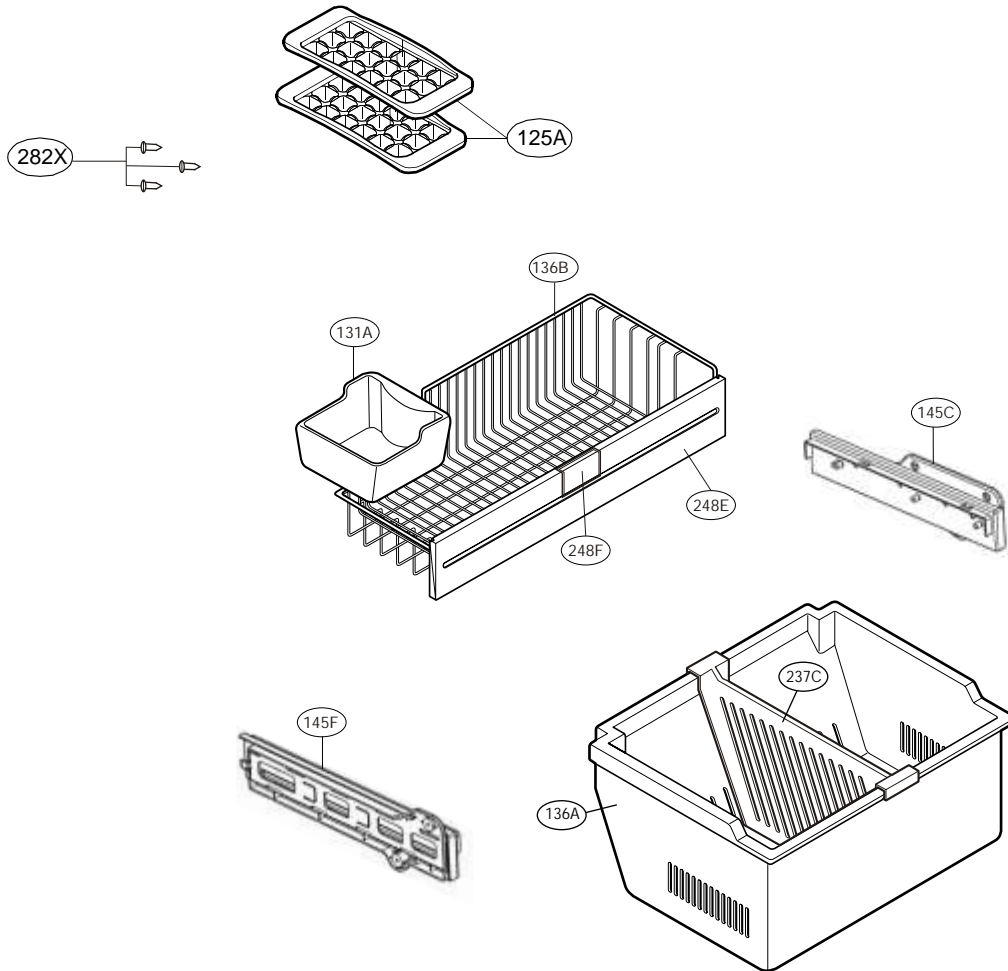

REFRIGERATOR PARTS

CAUTION: Use the part number to order part, not the position number.

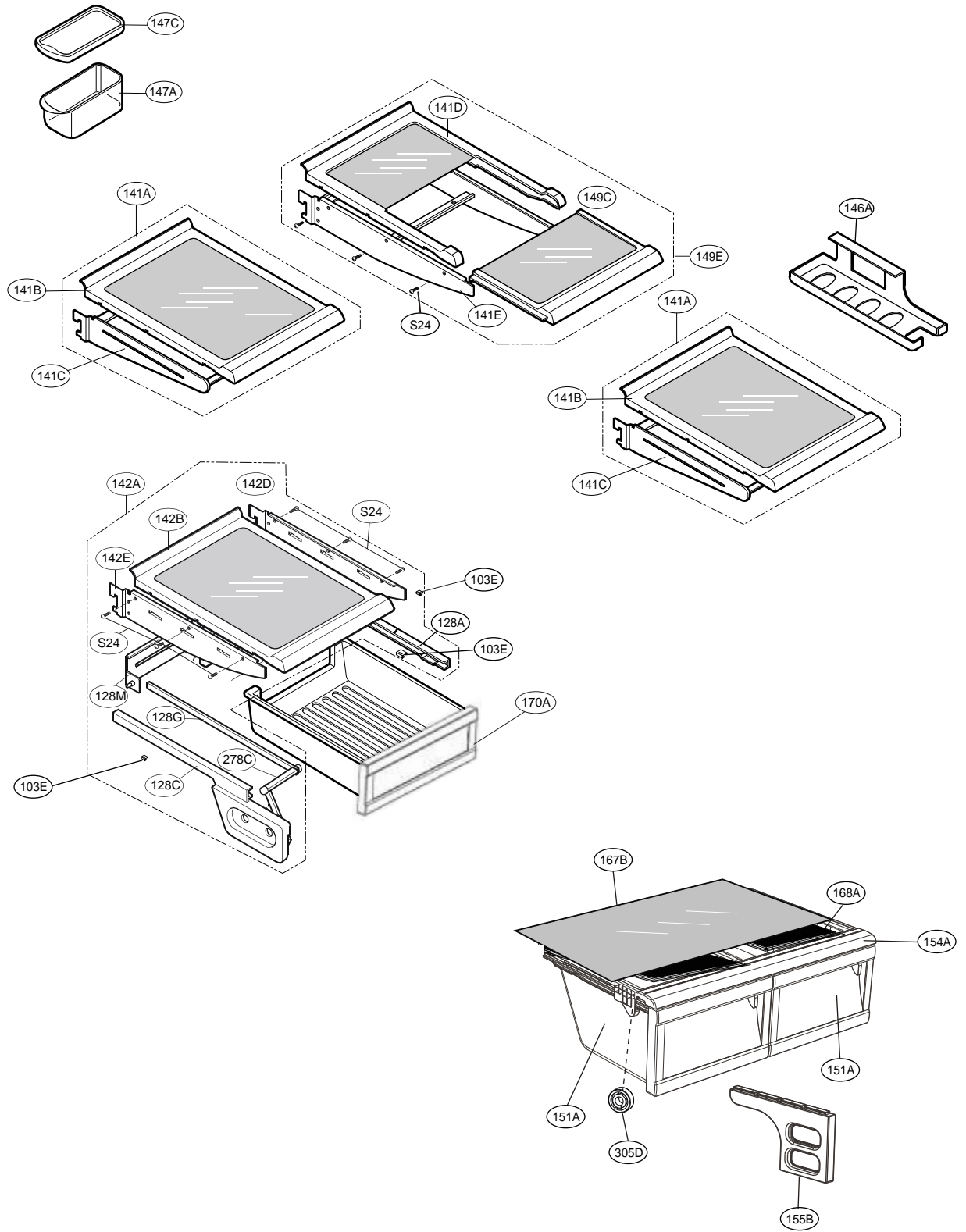

DOOR PARTS

CAUTION: Use the part number to order part, not the position number.

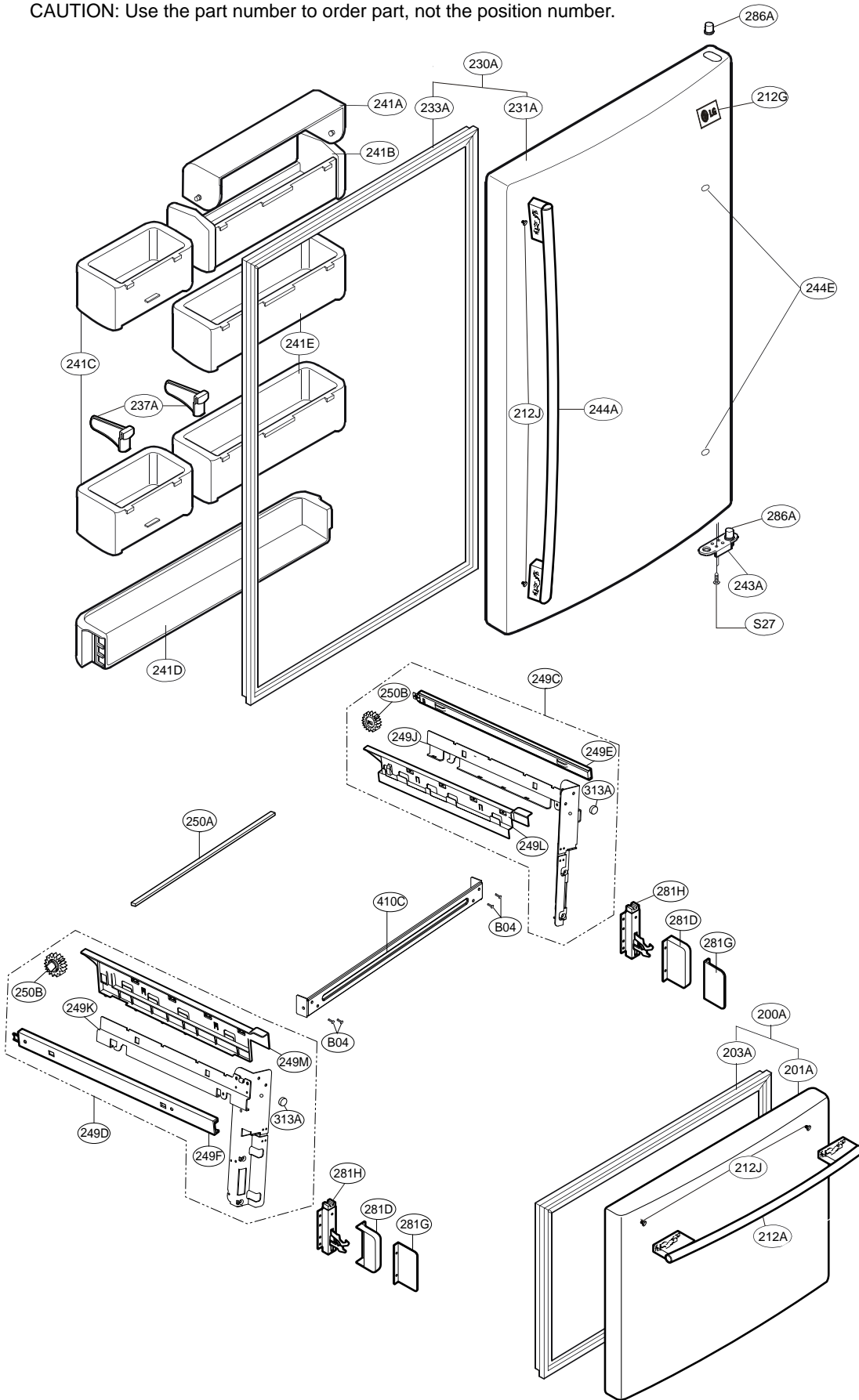

Loc No.	Part No.	Description	Loc No.	Part No.	Description
103A	3650JJ2003M	Handle,Rear	249M	MCK30136702	Cover,Connector
103B	3650JJ2003L	Handle,Rear	250A	4270JJ3001E	Bar
103C	3551JJ1015F	Cover Assembly,Lower	250B	4403JJ3001A	Connector Assembly
103E	5218JJ3001A	Rail,Slide	278C	4510JJ2003A	LEVER,SHUTTER
105A	5251JA3003B	Tube Assembly,Drain	281A	3550JJ2013C	Cover,Hinge
105F	5070JJ3002A	Skirt,Lower	281B	4775JJ2003B	Hinge Assembly,Upper
106A	4779JA2003A	Leg Assembly,Adjust	281D	3550JJ2043A	Cover,Hinge
106B	4J00382C	Washer,Common	281G	3550JJ2044A	Cover,Hinge
120B	5209JJ1002A	Duct Assembly,Multi	281H	4775JJ2011B	Hinge Assembly,Lower
125A	3390JJ1023A	Tray,Ice	282B	4775JJ8002C	Hinge Assembly,Center
125D	4930JJ3007A	Holder,Bracket	282E	5006JJ2001F	Cap,Hinge
128A	4975JJ2002A	Guide Assembly,Rail	282F	3806JL2006F	Decor,Duct
128C	4975JJ2003D	Guide Assembly,Rail	282H	5006JJ3004E	Cap,Hinge
128E	4930JJ1025A	Holder,Rail	282X	5006JJ3010A	Cap,Handle
128F	4930JJ1025B	Holder,Rail	284B	3550JA3120A	Cover,Connector
128G	4520JJ2001A	Link	284E	3550JJ3001A	Cover,Tube
128M	4974JJ2011A	Guide,Air	286A	4984JJ3003A	BUSH
131A	5074JJ1055A	BUCKET,ICE	301A	5421JJ1001B	Evaporator Assembly
135C	3550JJ2030A	Cover,Grille Fan	304A	3551JJ2008B	Cover Assembly,Machinery(Rear)
136A	3391JJ1011B	Tray Assembly,Drawer	305B	4580JJ3001A	Roller
136B	3390JJ1090A	Tray,Drawer	305C	4J04238A	Pin,Common
141A	5027JJ1014F	Shelf Assembly,Refrigerator	305D	4580JA3042A	Roller
141B	5027JJ1038A	Shelf Assembly,Refrigerator	307A	2521CRA5715	Compressor,Set Assembly
141C	5027JJ2005U	Shelf Assembly,Net	308A	EBG32606502	Thermistor Assembly,PTC
141D	5027JJ2011B	Shelf Assembly,Refrigerator	309A	6750C-0004S	Overload Protect
141E	5027JJ2005V	Shelf Assembly,Net	310A	3550JA2059A	Cover,PTC
142A	5027JJ1013J	Shelf Assembly,Refrigerator	312A	5040JA3031A	Damper,Compressor
142B	5027JJ1039A	Shelf Assembly,Refrigerator	313A	5040JJ3007A	Damper
142D	5026JJ2001L	Shelf,Net	314A	4620JA3009A	Stopper,Compressor
142E	5026JJ2001M	Shelf,Net	315A	3103JJ1001J	Base Assembly,Compressor
145A	4930JJ2003A	Holder,Shelf	317A	5851JJ2002F	Drier Assembly
145B	4930JJ2004A	Holder,Shelf	318A	4930JA3034A	Holder,Drier
145C	4975JJ2028C	Guide Assembly,Rail	319A	3390JJ0003A	Tray,Drip
145F	4975JJ2028D	Guide Assembly,Rail	319C	4974JJ1009A	Guide,Fan
146A	5047JJ1001A	Case,Lower	319E	4810JJ2005A	Bracket,Motor
147A	5074JJ1005A	Bucket,Dairy	323B	5403JJ1007A	Condenser Assembly,Wire
147C	3550JJ1017A	Cover,Bucket	327A	5006JA3034A	Cap,Drain Tube
149C	5027JJ2010B	Shelf Assembly,Refrigerator	328A	4J03020A	Damper,Pipe
149E	5027JJ2009D	Shelf Assembly,Refrigerator	329A	5901JJ1005A	Fan Assembly
151A	3391JJ1038A	Tray Assembly,Vegetable	329C	5901JJ1004B	Fan Assembly
154A	3550JJ1108A	Cover,TV	332A	3531JJ1004A	Grille Assembly,Fan
155B	4980JJ1016A	SUPPORTER,COVER TV	401A	6615JB2005C	Controller Assembly
158A	3550JJ1040A	Cover,Lamp	404A	4681JK1004A	AC Motor
158E	MCK30060901	Cover,Lamp	405A	4811JJ2002A	Bracket Assembly,Motor
167B	4890JL1002H	Shelf,Glass	405C	5040JA2009B	Damper,Motor Support
168A	3550JJ1035A	Cover,Magic Room	405F	5040JA2004B	Damper,Motor Support
170A	3391JJ2018A	Tray Assembly,Meat	405G	4811JJ2002H	Bracket Assembly,Motor
200A	3581JJ8715B	Door Assembly,Freezer	406B	6600JB1004A	Switch,Push Button
201A	5433JJ0058R	Door Foam Assembly,Freezer	409B	6912JB2004M	Lamp,Incandescent
203A	4987JJ1004E	Gasket Assembly,Door	409D	3034JJ1002B	Reflector,Lamp
205B	5006JJ2014A	CAP,COVER	410A	6621JK2002D	Drawing,Assembly
205C	5006JJ2014B	CAP,COVER	410C	4932JJ2006C	Connector,Tilt
212A	3651JA1033M	Handle Assembly,Freezer	410G	0CZZJB2012J	Capacitor,Electric Appliance Film,Box
212J	4620JJ3007E	Stopper,Handle	411A	6411JK1006A	Power Cord Assembly
212G	3846JD1007G	Name Plate	418A	5300JB1100J	Heater,Sheath
230A	3581JJ8716B	Door Assembly,Refrigerator	420A	4680JK1001B	Motor,AC
231A	5433JJ0019Y	Door Foam Assembly,Refrigerator	501A	EBR30659301	PCB Assembly,Main
233A	4987JJ1004F	Gasket Assembly,Door	501F	3551JJ1020A	Cover Assembly,PCB
237A	4974JJ2012A	Guide,Pitcher	503C	6871JB2046B	PCB Assembly,Display
237C	4974JJ1021A	Guide,Drawer	503D	3110JJ1005A	Case,Display
241A	3550JL2003H	Cover,Tray	503E	3550JJ2032A	Cover,Display
241B	5004JJ1021A	Basket,Door	503F	ABQ33905303	Case Assembly,Display
241C	5005JJ2017A	Basket Assembly,Door	503G	3806JL1053A	Decor,Control
241D	5005JJ2020A	Basket Assembly,Door	610A	3550JJ2020A	Cover,Sensor
241E	5005JJ2018A	Basket Assembly,Door	619B	3550JJ2024A	Cover,Valve
243A	4620JJ3006C	Stopper,Door	623H	3550JJ2036A	Cover,Tube
244A	3651JA1023V	Handle Assembly,Freezer	903A	3550JJ0006C	Cover,Lower
244E	5006JJ3016C	Cap,Handle	903B	4930JJ2021A	Holder,Cover(Lower)
248E	3806JJ1048A	Decor,Tray	903D	6500JK1003A	Sensor
248F	3806JL2011A	Decor,Tray	903E	6500JK1004A	Sensor
249C	ACJ32471702	Connector Assembly	B01	1STZJA3004F	Screw,Customized
249D	ACJ32471701	Connector Assembly	B04	1STZJA3001B	Screw,Customized
249E	5218JA1010E	Rail,Slide	S01	1SZZJJ3010A	Screw,Customized
249F	5218JA1010F	Rail,Slide	S22	J471-00001J	Screw,Customized
249J	ACJ32308804	Connector Assembly	S24	1SZZJA3011B	Screw,Customized
249K	ACJ32308803	Connector Assembly	S27	4J01424C	Screw,Customized
249L	MCK30136701	Cover,Connector	S38	4J00415D	Screw,Customized

Loc No.	Part No.	Description	Loc No.	Part No.	Description
103A	3650JJ2003M	Handle,Rear	249M	MCK30136702	Cover,Connector
103B	3650JJ2003L	Handle,Rear	250A	4270JJ3001E	Bar
103C	3551JJ1015F	Cover Assembly,Lower	250B	4403JJ3001A	Connector Assembly
103E	5218JJ3001A	Rail,Slide	278C	4510JJ2003A	LEVER,SHUTTER
105A	5251JA3003B	Tube Assembly,Drain	281A	3550JJ2013C	Cover,Hinge
105F	5070JJ3002A	Skirt,Lower	281B	4775JJ2003B	Hinge Assembly,Upper
106A	4779JA2003A	Leg Assembly,Adjust	281D	3550JJ2043A	Cover,Hinge
106B	4J00382C	Washer,Common	281G	3550JJ2044A	Cover,Hinge
120B	5209JJ1002A	Duct Assembly,Multi	281H	4775JJ2011B	Hinge Assembly,Lower
125A	3390JJ1023A	Tray,Ice	282B	4775JJ8002C	Hinge Assembly,Center
125D	4930JJ3007A	Holder,Bracket	282E	5006JJ2001F	Cap,Hinge
128A	4975JJ2002A	Guide Assembly,Rail	282F	3806JL2006F	Decor,Duct
128C	4975JJ2003D	Guide Assembly,Rail	282H	5006JJ3004E	Cap,Hinge
128E	4930JJ1025A	Holder,Rail	282X	5006JJ3010A	Cap,Handle
128F	4930JJ1025B	Holder,Rail	284B	3550JA3120A	Cover,Connector
128G	4520JJ2001A	Link	284E	3550JJ3001A	Cover,Tube
128M	4974JJ2011A	Guide,Air	286A	4984JJ3003A	BUSH
131A	5074JJ1055A	BUCKET,ICE	301A	5421JJ1001B	Evaporator Assembly
135C	3550JJ2030A	Cover,Grille Fan	304A	3551JJ2008B	Cover Assembly,Machinery(Rear)
136A	3391JJ1011B	Tray Assembly,Drawer	305B	4580JJ3001A	Roller
136B	3390JJ1090A	Tray,Drawer	305C	4J04238A	Pin,Common
141A	5027JJ1014F	Shelf Assembly,Refrigerator	305D	4580JA3042A	Roller
141B	5027JJ1038A	Shelf Assembly,Refrigerator	307A	2521CRA5715	Compressor,Set Assembly
141C	5027JJ2005U	Shelf Assembly,Net	308A	EBG32606502	Thermistor Assembly,PTC
141D	5027JJ2011B	Shelf Assembly,Refrigerator	309A	6750C-0004S	Overload Protect
141E	5027JJ2005V	Shelf Assembly,Net	310A	3550JA2059A	Cover,PTC
142A	5027JJ1013J	Shelf Assembly,Refrigerator	312A	5040JA3031A	Damper,Compressor
142B	5027JJ1039A	Shelf Assembly,Refrigerator	313A	5040JJ3007A	Damper
142D	5026JJ2001L	Shelf,Net	314A	4620JA3009A	Stopper,Compressor
142E	5026JJ2001M	Shelf,Net	315A	3103JJ1001J	Base Assembly,Compressor
145A	4930JJ2003A	Holder,Shelf	317A	5851JJ2002F	Drier Assembly
145B	4930JJ2004A	Holder,Shelf	318A	4930JA3034A	Holder,Drier
145C	4975JJ2028C	Guide Assembly,Rail	319A	3390JJ0003A	Tray,Drip
145F	4975JJ2028D	Guide Assembly,Rail	319C	4974JJ1009A	Guide,Fan
146A	5047JJ1001A	Case,Lower	319E	4810JJ2005A	Bracket,Motor
147A	5074JJ1005A	Bucket,Dairy	323B	5403JJ1007A	Condenser Assembly,Wire
147C	3550JJ1017A	Cover,Bucket	327A	5006JA3034A	Cap,Drain Tube
149C	5027JJ2010B	Shelf Assembly,Refrigerator	328A	4J03020A	Damper,Pipe
149E	5027JJ2009D	Shelf Assembly,Refrigerator	329A	5901JJ1005A	Fan Assembly
151A	3391JJ1038A	Tray Assembly,Vegetable	329C	5901JJ1004B	Fan Assembly
154A	3550JJ1108A	Cover,TV	332A	3531JJ1004A	Grille Assembly,Fan
155B	4980JJ1016A	SUPPORTER,COVER TV	401A	6615JB2005C	Controller Assembly
158A	3550JJ1040A	Cover,Lamp	404A	4681JK1004A	AC Motor
158E	MCK30060901	Cover,Lamp	405A	4811JJ2002A	Bracket Assembly,Motor
167B	4890JL1002H	Shelf,Glass	405C	5040JA2009B	Damper,Motor Support
168A	3550JJ1035A	Cover,Magic Room	405F	5040JA2004B	Damper,Motor Support
170A	3391JJ2018A	Tray Assembly,Meat	405G	4811JJ2002H	Bracket Assembly,Motor
200A	3581JJ8715C	Door Assembly,Freezer	406B	6600JB1004A	Switch,Push Button
201A	5433JJ0058M	Door Foam Assembly,Freezer	409B	6912JB2004M	Lamp,Incandescent
203A	4987JJ1004E	Gasket Assembly,Door	409D	3034JJ1002B	Reflector,Lamp
205B	5006JJ2014A	CAP,COVER	410A	6621JK2002D	Drawing,Assembly
205C	5006JJ2014B	CAP,COVER	410C	4932JJ2006C	Connector,Tilt
212A	3651JA1033J	Handle Assembly,Freezer	410G	0CZZJB2012J	Capacitor,Electric Appliance Film,Box
212J	4620JJ3007E	Stopper,Handle	411A	6411JK1006A	Power Cord Assembly
212G	3846JD1007H	Name Plate	418A	5300JB1100J	Heater,Sheath
230A	3581JJ8716C	Door Assembly,Refrigerator	420A	4680JK1001B	Motor,AC
231A	5433JJ0019Z	Door Foam Assembly,Refrigerator	501A	EBR30659301	PCB Assembly,Main
233A	4987JJ1004F	Gasket Assembly,Door	501F	3551JJ1020A	Cover Assembly,PCB
237A	4974JJ2012A	Guide,Pitcher	503C	6871JB2046B	PCB Assembly,Display
237C	4974JJ1021A	Guide,Drawer	503D	3110JJ1005A	Case,Display
241A	3550JL2003H	Cover,Tray	503E	3550JJ2032A	Cover,Display
241B	5004JJ1021A	Basket,Door	503F	ABQ33905303	Case Assembly,Display
241C	5005JJ2017A	Basket Assembly,Door	503G	3806JL1053A	Decor,Control
241D	5005JJ2020A	Basket Assembly,Door	610A	3550JJ2020A	Cover,Sensor
241E	5005JJ2018A	Basket Assembly,Door	619B	3550JJ2024A	Cover,Valve
243A	4620JJ3006C	Stopper,Door	623H	3550JJ2036A	Cover,Tube
244A	3651JA1023U	Handle Assembly,Freezer	903A	3550JJ0006C	Cover,Lower
244E	5006JJ3016D	Cap,Handle	903B	4930JJ2021A	Holder,Cover(Lower)
248E	3806JJ1048A	Decor,Tray	903D	6500JK1003A	Sensor
248F	3806JL2011A	Decor,Tray	903E	6500JK1004A	Sensor
249C	ACJ32471702	Connector Assembly	B01	1STZJA3004F	Screw,Customized
249D	ACJ32471701	Connector Assembly	B04	1STZJA3001B	Screw,Customized
249E	5218JA1010E	Rail,Slide	S01	1SZZJJ3010A	Screw,Customized
249F	5218JA1010F	Rail,Slide	S22	J471-00001J	Screw,Customized
249J	ACJ32308804	Connector Assembly	S24	1SZZJA3011B	Screw,Customized
249K	ACJ32308803	Connector Assembly	S27	4J01424C	Screw,Customized
249L	MCK30136701	Cover,Connector	S38	4J00415D	Screw,Customized

Loc No.	Part No.	Description	Loc No.	Part No.	Description
103A	3650JJ2003E	Handle,Rear	249M	MCK30136702	Cover,Connector
103B	3650JJ2003A	Handle,Rear	250A	4270JJ3001E	Bar
103C	3551JJ1015B	Cover Assembly,Lower	250B	4403JJ3001A	Connector Assembly
103E	5218JJ3001A	Rail,Slide	278C	4510JJ2003A	LEVER,SHUTTER
105A	5251JA3003B	Tube Assembly,Drain	281A	3550JJ2013A	Cover,Hinge
105F	5070JJ3002A	Skirt,Lower	281B	4775JJ2003B	Hinge Assembly,Upper
106A	4779JA2003A	Leg Assembly,Adjust	281D	3550JJ2043A	Cover,Hinge
106B	4J00382C	Washer,Common	281G	3550JJ2044A	Cover,Hinge
120B	5209JJ1002A	Duct Assembly,Multi	281H	4775JJ2011B	Hinge Assembly,Lower
125A	3390JJ1023A	Tray,Ice	282B	4775JJ8002A	Hinge Assembly,Center
125D	4930JJ3007A	Holder,Bracket	282E	5006JJ2001A	Cap,Hinge
128A	4975JJ2002A	Guide Assembly,Rail	282F	3806JL2006F	Decor,Duct
128C	4975JJ2003D	Guide Assembly,Rail	282H	5006JJ3004A	Cap,Hinge
128E	4930JJ1025A	Holder,Rail	282X	5006JJ3010A	Cap,Handle
128F	4930JJ1025B	Holder,Rail	284B	3550JA3120A	Cover,Connector
128G	4520JJ2001A	Link	284E	3550JJ3001A	Cover,Tube
128M	4974JJ2011A	Guide,Air	286A	4984JJ3003A	BUSH
131A	5074JJ1055A	BUCKET,ICE	301A	5421JJ1001B	Evaporator Assembly
135C	3550JJ2030A	Cover,Grille Fan	304A	3551JJ2008B	Cover Assembly,Machinery(Rear)
136A	3391JJ1011B	Tray Assembly,Drawer	305B	4580JJ3001A	Roller
136B	3390JJ1090A	Tray,Drawer	305C	4J04238A	Pin,Common
141A	5027JJ1014F	Shelf Assembly,Refrigerator	305D	4580JA3042A	Roller
141B	5027JJ1038A	Shelf Assembly,Refrigerator	307A	2521CRA5715	Compressor,Set Assembly
141C	5027JJ2005U	Shelf Assembly,Net	308A	EBG32606502	Thermistor Assembly,PTC
141D	5027JJ2011B	Shelf Assembly,Refrigerator	309A	6750C-0004S	Overload Protect
141E	5027JJ2005V	Shelf Assembly,Net	310A	3550JA2059A	Cover,PTC
142A	5027JJ1013J	Shelf Assembly,Refrigerator	312A	5040JA3031A	Damper,Compressor
142B	5027JJ1039A	Shelf Assembly,Refrigerator	313A	5040JJ3007A	Damper
142D	5026JJ2001L	Shelf,Net	314A	4620JA3009A	Stopper,Compressor
142E	5026JJ2001M	Shelf,Net	315A	3103JJ1001J	Base Assembly,Compressor
145A	4930JJ2003A	Holder,Shelf	317A	5851JJ2002F	Drier Assembly
145B	4930JJ2004A	Holder,Shelf	318A	4930JA3034A	Holder,Drier
145C	4975JJ2028C	Guide Assembly,Rail	319A	3390JJ0003A	Tray,Drip
145F	4975JJ2028D	Guide Assembly,Rail	319C	4974JJ1009A	Guide,Fan
146A	5047JJ1001A	Case,Lower	319E	4810JJ2005A	Bracket,Motor
147A	5074JJ1005A	Bucket,Dairy	323B	5403JJ1007A	Condenser Assembly,Wire
147C	3550JJ1017A	Cover,Bucket	327A	5006JA3034A	Cap,Drain Tube
149C	5027JJ2010B	Shelf Assembly,Refrigerator	328A	4J03020A	Damper,Pipe
149E	5027JJ2009D	Shelf Assembly,Refrigerator	329A	5901JJ1005A	Fan Assembly
151A	3391JJ1038A	Tray Assembly,Vegetable	329C	5901JJ1004B	Fan Assembly
154A	3550JJ1108A	Cover,TV	332A	3531JJ1004A	Grille Assembly,Fan
155B	4980JJ1016A	SUPPORTER,COVER TV	401A	6615JB2005C	Controller Assembly
158A	3550JJ1040A	Cover,Lamp	404A	4681JK1004A	AC Motor
158E	MCK30060901	Cover,Lamp	405A	4811JJ2002A	Bracket Assembly,Motor
167B	4890JL1002H	Shelf,Glass	405C	5040JA2009B	Damper,Motor Support
168A	3550JJ1035A	Cover,Magic Room	405F	5040JA2004B	Damper,Motor Support
170A	3391JJ2018A	Tray Assembly,Meat	405G	4811JJ2002H	Bracket Assembly,Motor
200A	3581JJ8715A	Door Assembly,Freezer	406B	6600JB1004A	Switch,Push Button
201A	5433JJ0058V	Door Foam Assembly,Freezer	409B	6912JB2004M	Lamp,Incandescent
203A	4987JJ1004A	Gasket Assembly,Door	409D	3034JJ1002B	Reflector,Lamp
205B	5006JJ2014A	CAP,COVER	410A	6621JK2002D	Drawing,Assembly
205C	5006JJ2014B	CAP,COVER	410C	4932JJ2006C	Connector,Tilt
212A	3651JA1033K	Handle Assembly,Freezer	410G	0CZZJB2012J	Capacitor,Electric Appliance Film,Box
212J	4620JJ3007E	Stopper,Handle	411A	6411JK1006A	Power Cord Assembly
212G	3846JD1007F	Name Plate	418A	5300JB1100J	Heater,Sheath
230A	3581JJ8716A	Door Assembly,Refrigerator	420A	4680JK1001B	Motor,AC
231A	5433JJ0019X	Door Foam Assembly,Refrigerator	501A	EBR30659301	PCB Assembly,Main
233A	4987JJ1004B	Gasket Assembly,Door	501F	3551JJ1020A	Cover Assembly,PCB
237A	4974JJ2012A	Guide,Pitcher	503C	6871JB2046B	PCB Assembly,Display
237C	4974JJ1021A	Guide,Drawer	503D	3110JJ1005A	Case,Display
241A	3550JL2003H	Cover,Tray	503E	3550JJ2032A	Cover,Display
241B	5004JJ1021A	Basket,Door	503F	ABQ33905303	Case Assembly,Display
241C	5005JJ2017A	Basket Assembly,Door	503G	3806JL1053A	Decor,Control
241D	5005JJ2020A	Basket Assembly,Door	610A	3550JJ2020A	Cover,Sensor
241E	5005JJ2018A	Basket Assembly,Door	619B	3550JJ2024A	Cover,Valve
243A	4620JJ3006A	Stopper,Door	623H	3550JJ2036A	Cover,Tube
244A	3651JA1023X	Handle Assembly,Freezer	903A	3550JJ0006A	Cover,Lower
244E	5006JJ3016A	Cap,Handle	903B	4930JJ2021A	Holder,Cover(Lower)
248E	3806JJ1048A	Decor,Tray	903D	6500JK1003A	Sensor
248F	3806JL2011A	Decor,Tray	903E	6500JK1004A	Sensor
249C	ACJ32471702	Connector Assembly	B01	1STZJA3004F	Screw,Customized
249D	ACJ32471701	Connector Assembly	B04	1STZJA3001B	Screw,Customized
249E	5218JA1010E	Rail,Slide	S01	1SZZJJ3010A	Screw,Customized
249F	5218JA1010F	Rail,Slide	S22	J471-00001J	Screw,Customized
249J	ACJ32308804	Connector Assembly	S24	1SZZJA3011B	Screw,Customized
249K	ACJ32308803	Connector Assembly	S27	4J01424C	Screw,Customized
249L	MCK30136701	Cover,Connector	S38	4J00415D	Screw,Customized



May 19, 2008

MFL31442401
Rev.01