

This Owner's Manual is provided and hosted by [Appliance Factory Parts](http://Appliance Factory Parts).



# LG MS-72NA Owner's Manual

[Shop genuine replacement parts for LG MS-72NA](#)

## DOOR PARTS

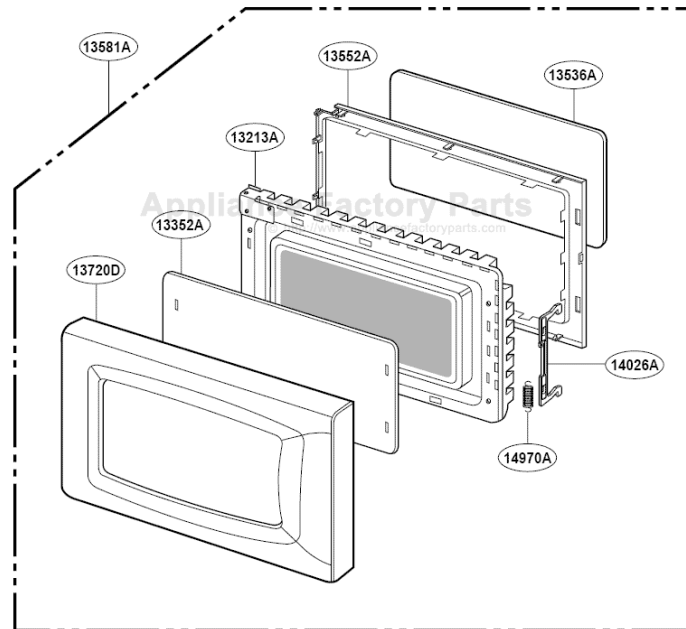

[Find Your LG Microwave Parts - Select From 955 Models](#)

----- Manual continues below -----



Website: <http://biz.lgservice.com>

# MICROWAVE OVEN SERVICE MANUAL

**MODEL: MS-72NA**

**CAUTION**

BEFORE SERVICING THE UNIT, READ THE SAFETY PRECAUTIONS IN THIS MANUAL.



P/NO : 3828W5S1787

April, 2001  
Printed in Korea

# SAFETY PRECAUTIONS

This device is to be serviced only by properly qualified service personnel.

Consult the service manual for proper service procedures to assure continued safety operation and for precautions to be taken to avoid possible exposure to excessive microwave energy.

## **PRECAUTIONS TO BE OBSERVED BEFORE AND DURING SERVICING TO AVOID POSSIBLE EXPOSURE TO EXCESSIVE MICROWAVE ENERGY**

- A) Do not operate or allow the oven to be operated with the door open.
- B) Make the following safety checks on all ovens to be serviced before activating the magnetron or other microwave source, and make repairs as necessary; (1) interlock operation, (2) proper door closing, (3) seal and sealing surfaces (arcing, wear, and other damage), (4) damage to or loosening of hinges and latches, (5) evidence of dropping or abuse.
- C) Before turning on microwave power for any service test or inspection within the microwave generating compartments, check the magnetron, wave guide or transmission line, and cavity for proper alignment, integrity, and connections.
- D) Any defective or misadjusted components in the interlock, monitor, door seal, and microwave generation and transmission systems shall be repaired, replaced, or adjusted by procedures described in this manual before the oven is released to the owner.
- E) A microwave leakage check to verify compliance should be performed on each oven prior to release to the owner.

## **CAUTION MICROWAVE RADIATION**

**DO NOT BECOME EXPOSED TO RADIATION FROM THE MICROWAVE GENERATOR OR OTHER PARTS CONDUCTING MICROWAVE ENERGY.**

# CONTENTS

(Page)

<b>SAFETY PRECAUTIONS</b> .....	<b>Inside front cover</b>
<b>SPECIFICATIONS</b> .....	<b>1-1</b>
<b>CAUTIONS</b> .....	<b>2-1</b>
<b>INSTALLATIONS</b> .....	<b>3-1</b>
<b>OPERATING INSTRUCTIONS</b> .....	<b>4-1</b>
FEATURES.....	4-1
OPERATION CHECK .....	4-1
OPERATING PROCEDURE .....	4-1
SCHEMATIC DIAGRAM .....	4-2
CIRCUIT DESCRIPTION .....	4-3
<b>SERVICE INFORMATION</b> .....	<b>5-1</b>
TOOLS AND MEASURING INSTRUMENTS .....	5-1
MICROWAVE LEAKAGE TEST .....	5-1
MEASUREMENT OF MICROWAVE POWER OUTPUT .....	5-3
DISASSEMBLY AND ADJUSTMENT .....	5-3
INTERLOCK CONTINUITY TEST.....	5-8
COMPONENT TEST PROCEDURE .....	5-9
TROUBLE SHOOTING .....	5-12
<b>EXPLODED VIEW</b> .....	<b>6-1</b>
<b>REPLACEMENT PARTS LIST</b> .....	<b>7-1</b>

# SPECIFICATIONS

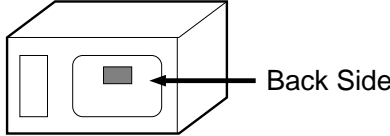
ITEM	DESCRIPTION
<b>MODEL</b>	<b>MS-72NA</b>
Power Requirement	120 Volts AC 60 Hz 1,050 Watts (9,3A) Single phase, 3 wire grounded
Power Output	700 Watts full microwave power (IEC60705)
Microwave Frequency	2,450 MHz
Magnetron	2M213-09
Timer	0 ~ 60 min.
Outside Dimensions	19" (W) x 11" (H) x 12 <sup>7</sup> / <sub>8</sub> " (D) mm
Cavity Dimensions	11 <sup>7</sup> / <sub>8</sub> " (W) x 7 <sup>5</sup> / <sub>8</sub> " (H) x 12 <sup>1</sup> / <sub>2</sub> " (D) mm
Net Weight	25 lbs (approx.)
Shipping weight	28 lbs (approx.)
Control Complement	Microwave Power for Variable Cooking Power level Máximo calentar Hornear ** Descongelar Entibiar
Nameplate Location	 <p>The diagram shows a 3D perspective view of the microwave oven's back panel. On the left side, there is a vertical rectangular slot. In the center, there is a square-shaped nameplate. An arrow points from the text 'Back Side' to the right side of the microwave, indicating the location of the nameplate.</p>
Accessories	Owner's manual & cooking guide Glass turntable Rotating ring
<p>This microwave oven is designed for household use only. It is not recommended for commercial purposes.</p>	

# CAUTIONS

Unlike other appliances, the microwave oven is high-voltage and high-current equipment. Though it is free from danger in ordinary use, extreme care should be taken during repair.

- DO NOT operate on a 2-wire extension cord during repair and use.
- NEVER TOUCH any oven components or wiring during operation.
- BEFORE TOUCHING any parts of the oven, always remove the power plug from the outlet.
- For about 30 seconds after the oven stops, an electric charge remains in the high voltage capacitor. When replacing or checking, you must discharge the high voltage capacitor by shorting across the two terminals with an insulated screwdriver.

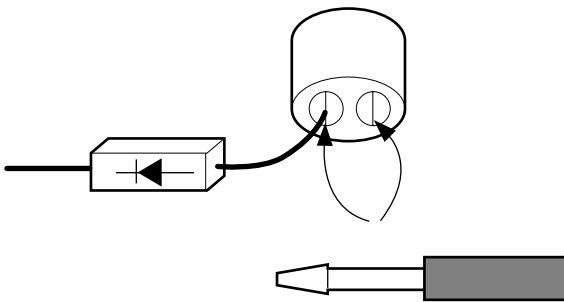

- Remove your watches whenever working close to or replacing the Magnetron.
- DO NOT touch any parts of the control panel circuit. A resulting static electric discharge may damage this P.C.B.
- NEVER operate the oven with no load.
- NEVER injure the door seal and front plate of the oven cavity.
- NEVER put iron tools on the magnetron.
- NEVER put anything into the latch hole and the interlock switches area.

## MICROWAVE RADIATION

Personnel should not be exposed to the microwave energy which may radiate from the magnetron or other microwave generating device if it is improperly used or connection. All input and output microwave connections, waveguide, flange, and gasket must be secure never operate the device without a microwave energy absorbing load attached. Never look into an open waveguide or antenna while the device is energized.

- Proper operation of the microwave oven requires that the magnetron be assembled to the waveguide and cavity. Never operate the magnetron unless it is properly installed.
- **Be sure that the magnetron gasket is properly installed around the dome of the tube whenever installing the magnetron.**

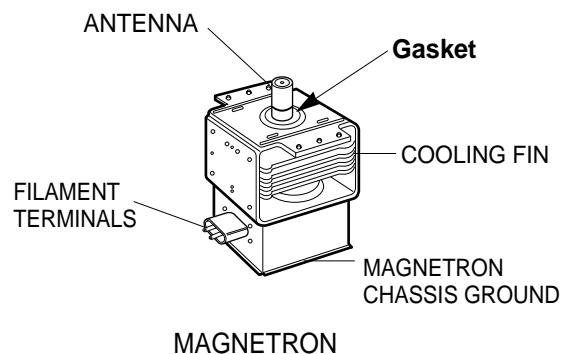

**THE OVEN IS TO BE SERVICED ONLY BY PROPERLY QUALIFIED SERVICE PERSONNEL.**

# INSTALLATIONS

**BEFORE YOU BEGIN, READ THE FOLLOWING INSTRUCTIONS COMPLETELY AND CAREFULLY.**

## INSTALLING

1. Empty the microwave oven and clean inside it with a soft, damp cloth. Check for damage such as misaligned door, damage around the door or dents inside the cavity or on the exterior.
2. Put the oven on a counter, table, or shelf that is strong enough to hold the oven and the food and utensils you put in it. (The control panel side of the oven is the heavy side. Use care when handling.)
3. Do not block the vent and the air intake openings. Blocking vent or air intake openings can cause damage to the oven and poor cooking results. Make sure the microwave oven legs are in place to ensure proper air flow.
4. The oven should not be installed in any area where heat and steam are generated, because they may damage the electronic or mechanical parts of the unit.  
Do not install the oven next to a conventional surface unit or above a conventional wall oven.
5. Use microwave oven in an ambient temperature less than 104°F(40°C).
6. Place the microwave oven on a sturdy and flat surface at least 10 cm(4 inches) from the wall.
7. Place the microwave oven as far away as possible from TV, RADIO, COMPUTER, etc., to prevent interference.

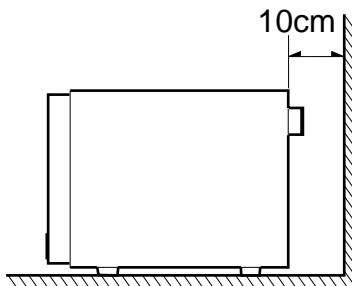

## GROUNDING INSTRUCTIONS

For personal safety, this appliance must be fully grounded at all times.

In the event of an electrical short circuit, grounding reduces the risk of electrical shock.

The plug must be plugged into an outlet that is properly installed and grounded.

### WARNING

Improper use of the grounding plug can result in a risk of electric shock.

Do not, under any circumstances, cut or remove the third ground prong from the power cord plug.

# OPERATING INSTRUCTIONS

## FEATURES

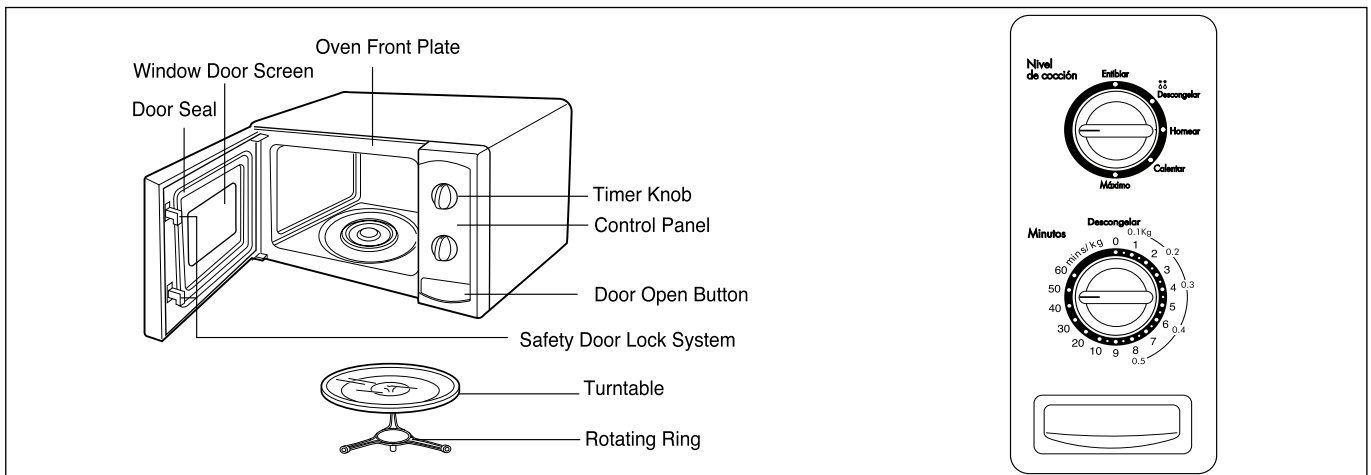

## OPERATION CHECK

After unpacking this appliance, examine the new oven for evidence of shipping damage. This is most important since a damaged oven may allow the escape of microwave energy. Make sure you remove all packing from the microwave cavity. Check the oven operation when unpacking the unit and any time the oven is not working properly.

1. Plug the power cord into an earthed electrical socket.

2. Place the glass tray inside the oven cavity.
3. Place a cup of water (at room temperature) inside the oven, on the glass tray.
4. Close the door securely.
5. Set the Timer for 3 to 4 minutes (note : microwave activity starts).
6. When the cooking time has elapsed, the signal will sound (note: all microwave activity stops).
7. If the oven is operating normally, the water will be hot.

## OPERATING PROCEDURE

The microwave oven is designed to be simple and easy to operate. Please follow these instructions carefully.

1. Place the food in a suitable cooking utensil. Open the microwave oven door and place the utensil in the center of the oven on the glass tray.
2. Close the oven door.
3. Turn the TIMER KNOB clockwise to set the cooking time.
4. When the TIMER reaches OFF, the signal sounds and the oven will automatically shut off.
5. Open the door and remove the food from the oven.

6. To stop cooking before the timer reaches OFF, either open the door or simply turn the timer to OFF.

### NOTE :

1. The oven starts cooking as soon as the timer knob is turned. Each number represents minutes. To ensure accurate timing, it is advisable to turn the timer slightly passed the desired cooking time and then back to the proposed setting.
2. The door can be opened during the cooking process by pushing the Door Open Button. The timer will stop and the microwave activity will cease. When the door is closed, cooking will resume until the full cooking time has elapsed. After cooking is finished, the Timer will be at OFF.



# SCHEMATIC DIAGRAM

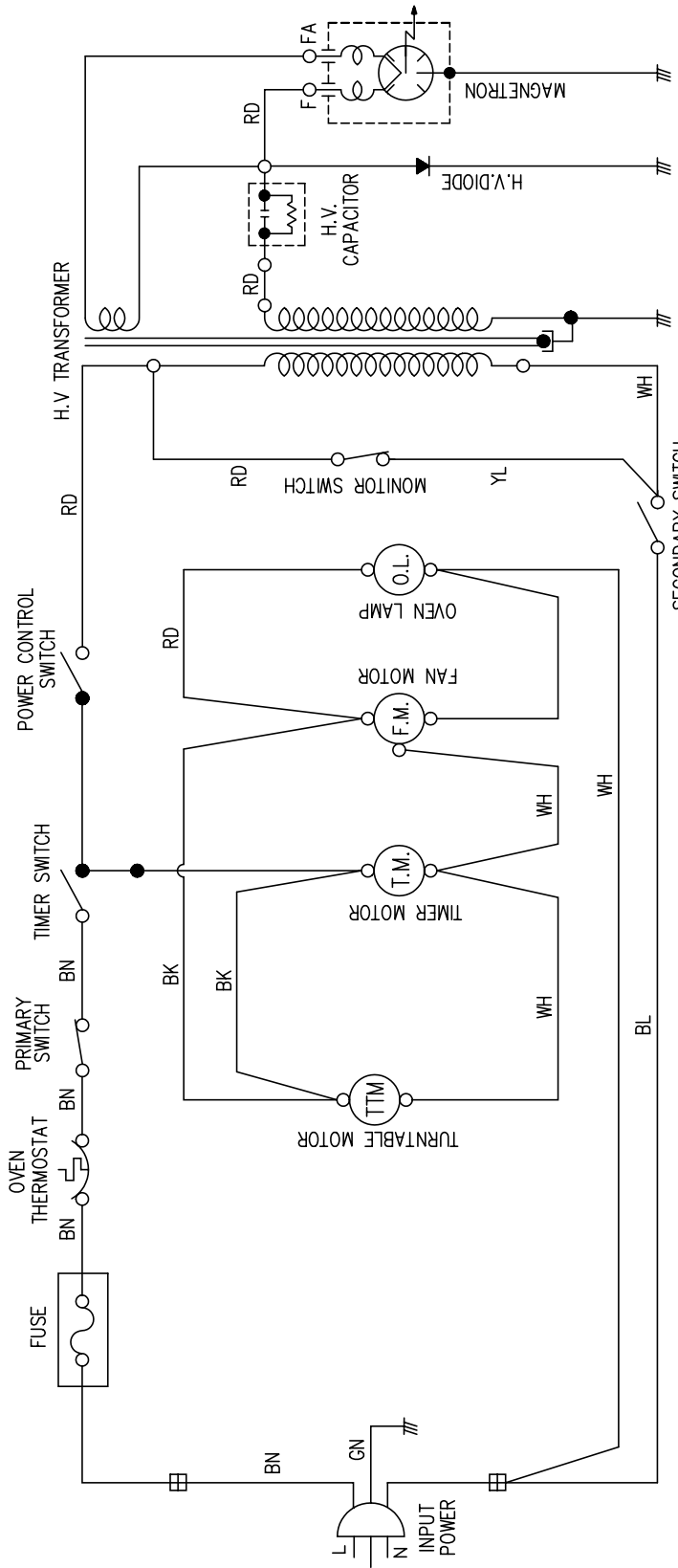

\* NOTE : DOOR IS OPENED.  
 BK:BLACK RD:RED YL:YELLOW  
 WH:WHITE PK:PINK BN:BROWN  
 BL:BLUE GN:GREEN

NOTE: 1.DOOR IS OPENED  
 2.COOK OFF.

SYMBOL	COLOR
G-Y	GREEN-YELLOW
WH	WHITE
BN	BROWN
BL	BLUE
RD	RED
YL	YELLOW
PK	PINK
BK	BLACK

BEFORE SERVICING Discharge the high voltage Capacitor by shorting the negative high voltage Terminal of it to chassis ground.

IMPORTANT SAFETY NOTE: THE COMPONENTS IN SHADED AREAS ON THIS SCHEMATIC DIAGRAM INCORPORATE SPECIAL FEATURES IMPORTANT FOR PROTECTION FROM MICROWAVE RADIATION, FIRE, ELECTRICAL SHOCK, AND OTHER HAZARDS. WHEN SERVICING IT IS ESSENTIAL THAT ONLY MANUFACTURER'S SPECIFIED PARTS BE USED FOR THE CRITICAL COMPONENTS IN THE SHADED AREAS OF THE SCHEMATIC DIAGRAM.

NOTICE: SINCE THIS IS A BASIC SCHEMATIC DIAGRAM, THE VALUES OF COMPONENTS AND SOME PARTIAL CONNECTIONS ARE SUBJECT TO CHANGE FOR IMPROVEMENT.

# CIRCUIT DESCRIPTION

## GENERAL DETAILS

- When the door is closed, the primary switch is ON, the secondary switch is ON, and the monitor switch opens (contact COM and NO).
- The latches are secured by the latch board, the oven light turns on while the oven is operation.

## WHEN THE TIMER KNOB IS ROTATED

- When the timer knob is rotated, the contacts of timer switch close.
- The contact of the secondary switch close the circuit.
- Power input is supplied to the high voltage transformer through the fuse to the primary timer and secondary switches.
- Turntable rotates
- The fan motor rotates and cools the magnetron by blowing the air (coming from the intake on the baseplate).
- The air is also directed into the oven to exhaust the vapor in the oven through the upper plate.
- Cooking time starts counting down.

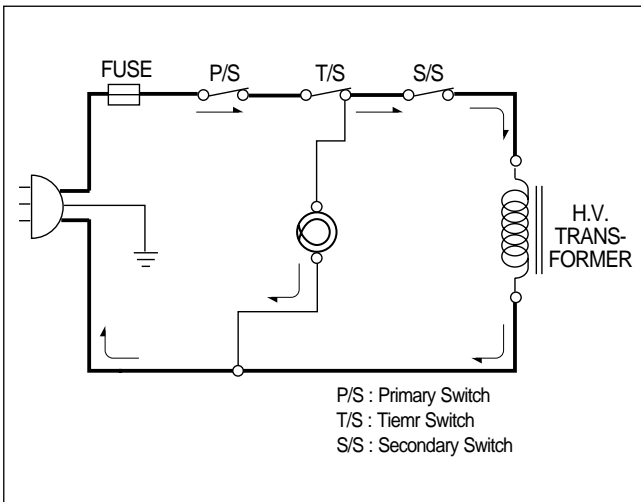

- 3.2 volts AC is generated from the filament winding of the high voltage transformer. This 3.2 volts is applied to the magnetron to heat the magnetron filament through two noise-preventing choke coils.

- A high voltage of approximately 2100 volts AC is generated in the secondary of the high voltage transformer which is increased by the action of the high voltage diode and charging of the high voltage capacitor.
- The negative 4,000 Volts DC is applied to the filament of the magnetron.

## WHEN THE DOOR IS OPENED DURING COOKING

- Both the primary and timer switches are cut off primary winding voltage of the high voltage transformer.
- When the door is opened, the secondary switch is opened and when the door is closed, the secondary switch is closed.
- The timer, turntable and fan motor stop.
- As the door is opened, if the contact of primary switch fail to open, the fuse opens due to the large current surge caused by the monitor switch activation, which in turn stops magnetron oscillation.

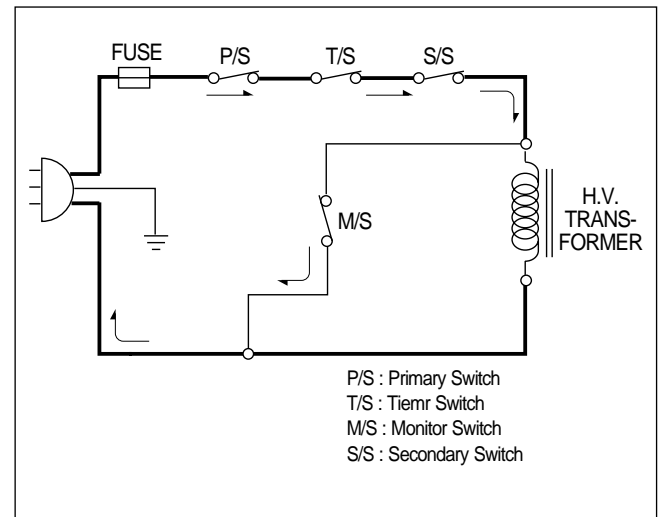

# SERVICE INFORMATION

## TOOLS AND MEASURING INSTRUMENTS

### NECESSARY TOOLS

Tools normally used for TV servicing are sufficient. Standard tools are listed below.

- Diagonal pliers
- Long nose pliers
- Phillips screwdriver
- Flat blade screwdriver
- Wrench (size 5mm)
- Nutdriver (size 5mm)
- Adjustable wrench
- Soldering iron
- Solder
- Vinyl insulation tape
- Polishing cloth

### NECESSARY MEASURING INSTRUMENTS

- TESTER (VOLTS-DC, AC, Ohmmeter)
- Microwave survey meter
  - Holaday HI-1500  
HI-1501
  - Narda 8100  
8200
- Inch scale
- 600 cc non conductive material beaker (glass or plastic), inside diameter: approx. 8.5 cm (3<sup>1</sup>/<sub>2</sub> in.)
- Cylindrical and made of borosilicate glass vessel.  
max. thickness: 3 mm  
outside diameter: approx. 190mm  
height: approx. 90mm
- Glass thermometer: 100°C or 212°F (1 deg scale)

## MICROWAVE LEAKAGE TEST

### CAUTIONS

- Be sure to check microwave leakage prior to servicing the oven if the oven is operative prior to servicing.
- The service personnel should inform the manufacturer, importer, or assembler of any certified oven unit found to have a microwave emission level in excess of 5 mW/cm<sup>2</sup> and should repair any unit found to have excessive emission levels at no cost to the owner and should ascertain the cause of the excessive leakage. The service personnel should instruct the owner not to use the unit until the oven has been brought into compliance.
- If the oven operates with the door open, the service personnel should:
  - Tell the user not to operate the oven.
  - Contact the manufacturer.
- The service personnel should check all surface and vent openings for microwave leakage.
- Check for microwave leakage after every servicing. The power density of the microwave radiation leakage emitted by the microwave oven should not exceed 4 mW/cm<sup>2</sup>. Always start measuring of an unknown field to assure safety for operating personnel from radiation leakage.

### MEASURING MICROWAVE ENERGY LEAKAGE

- Pour 275±15cc of 20±5°C(68±9°F) water in a beaker which is graduated to 600 cc, and place the beaker on the center of the turntable.
- Set the energy leakage monitor to 2,450 MHz and use it following the manufacturer's recommended test procedure to assure correct result.
- When measuring the leakage, always use the 2-inch (5cm) spacer supplied with the probe.
- Operate the oven at its maximum output.
- Measure the microwave radiation using and electromagnetic radiation monitor by holding the probe perpendicular to the surface being measured

Move probe along shaded area

////////////////////  
Probe scanning speed  
Less than 2.5 cm/sec  
( 1in/sec)

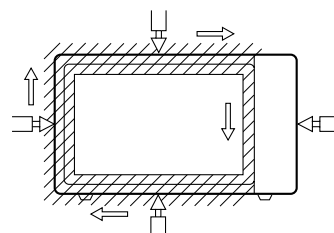

## **MEASUREMENT WITH OUTER CASE REMOVED**

- When you replace the magnetron, measure for microwave energy leakage before the outer case is installed and after all necessary components are replaced or adjusted. Special care should be taken in measuring the following parts. (Circled area of below Fig.)
  - Around the magnetron
  - The waveguide

**WARNING : AVOID CONTACTING ANY HIGH VOLTAGE PARTS**

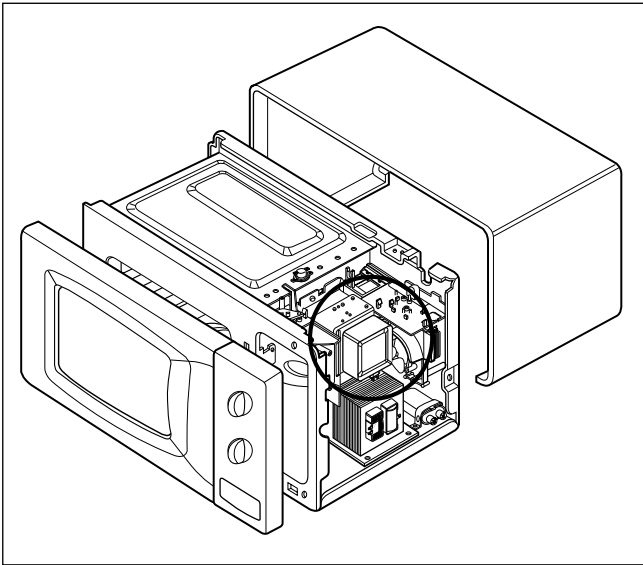

## **MEASUREMENT WITH A FULLY ASSEMBLED OVEN**

- After all components, including the outer case, are fully assembled, measure for microwave energy leakage around the door viewing window, the exhaust opening, and air inlet openings.
- Microwave energy leakage must not exceed the values prescribed below.

**NOTE:** Leakage with the outer case removed less than 5 mW/cm.sq. Leakage for a fully assembled oven (Before the latch switch (primary) is interrupted) with the door in a slightly opened position-less than 5 mW/cm.sq.

## **NOTES WHEN MEASURING**

- Do not exceed meter full scale deflection.
- The test probe must be removed no faster than 1 inch/sec (2.5 cm/sec) along the shaded area, otherwise a false reading may result.
- The test probe must be held with the grip portion of the handle. A false reading may result if the operator's hand is between the handle and the probe.
- When testing near a corner of the door, keep the probe perpendicular to the surface making sure the probe horizontally along the oven surface, this may possibly cause probe damage.

## **RECORD KEEPING AND NOTIFICATION AFTER MEASUREMENT**

- After adjustment and repair of any microwave energy interruption or microwave energy blocking device, record the measured values for future reference. Also enter the information on the service invoice.
- The microwave energy leakage should not be more than 5 mW/cm.sq. after determining that all parts are in good condition, functioning properly and genuine replacement parts which are listed in this manual have been used.
- At least once a year, have the electromagnetic energy leakage monitor checked for calibration by its manufacturer.

# MEASUREMENT OF MICROWAVE POWER OUTPUT

- Microwave power output measurement is made with the microwave oven supplied at its rated voltage and operated at its maximum microwave power setting with a load of (1000±5) g of potable water.
- The water is contained in a cylindrical borosilicate glass vessel having a maximum material thickness of 3 mm and an outside diameter of approximately 190mm.
- The oven and the empty vessel are at ambient temperature prior to the start of the test.
- The initial temperature (T1) of the water is (10±2)°C It is measured immediately before the water is added to the vessel. After addition of the water to the vessel, the load is immediately placed on the center of the turntable which is in the lowest position and the microwave power switched on.
- The time T for the temperature of the water to rise by a value  $\Delta T$  of (10±2)°K is measured, where T is the time in seconds and  $\Delta T$  is the temperature rise. The initial and final water temperatures are selected so that the maximum difference between the final water temperature and the ambient temperature is 5°K.

- The microwave power output P in watts is calculated from the following formula :

$$P = \frac{4187 \times (\Delta T)}{T}$$

is measured while the microwave generator is operating at full power. Magnetron filament heat-up time is not included. (about 3 sec)

- The water is stirred to equalize temperature throughout the vessel, prior to measuring the final water temperature.
- Stirring devices and measuring instruments are selected in order to minimize addition or removal of heat.

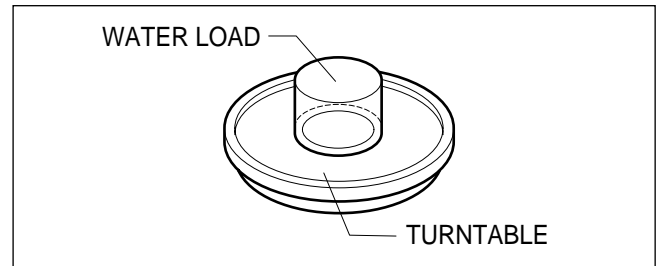

## DISASSEMBLY AND ADJUSTMENT

### A. OUTER CASE REMOVAL

- 1) Disconnect the power supply cord from the outlet.
- 2) Remove the screws from the rear of the case.  
The outer case must be moved backward to be lifted off.

### B. POWER SUPPLY CORD

- 1) Remove the outer case.
- 2) Disconnect two terminals, and remove one screw of the ground terminal.

### C. CONTROL PANEL ASSEMBLY

- 1) Open the door.
- 2) Remove the screws for the ground and securing the control panel.
- 3) Disconnect the leadwires from the timer motor.
- 4) Lift up and pull out control panel assembly carefully from the cavity.

**CAUTION: DISCHARGE THE HIGH VOLTAGE CAPACITOR BEFORE SERVICING**  
(refer to page 2-1)

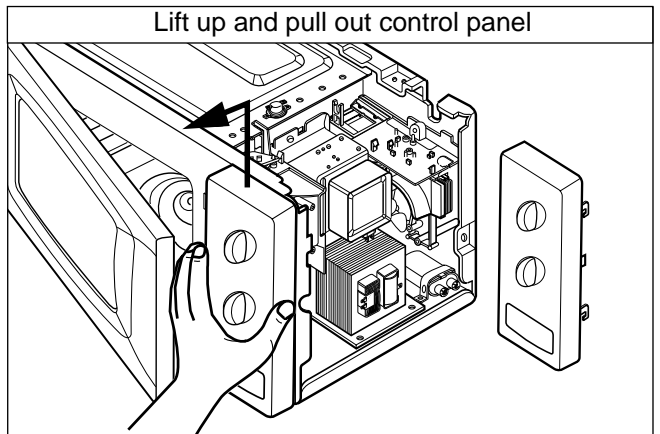
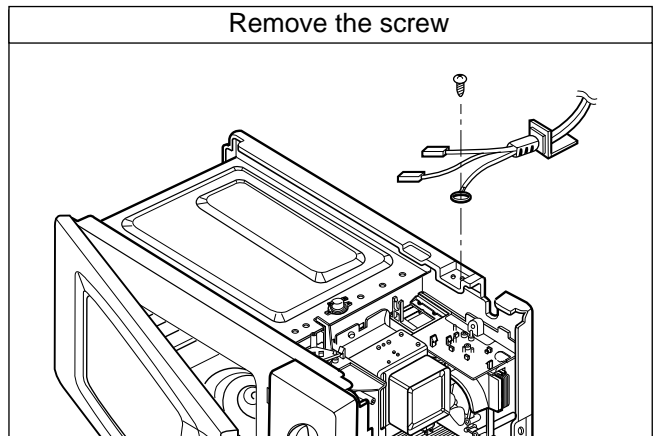

## D. TIMER MOTOR REMOVAL

- 1) Remove the control panel assembly from the cavity. (Refer to control panel assembly removal on previous page.)
- 2) Remove screws which hold the timer motor to the control panel.
- 3) Removed the timer knob.
- 4) Remove the door open button.

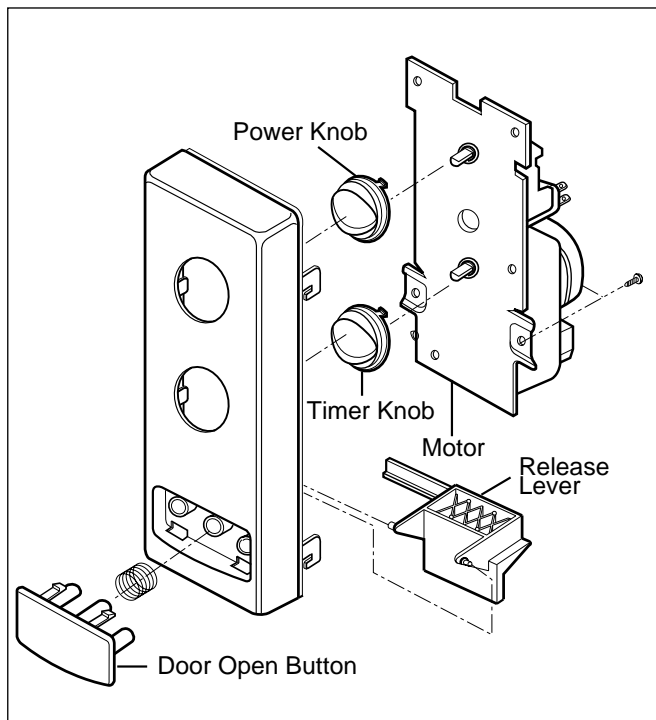

## E. DOOR MAIN ASSEMBLY REMOVAL

- 1) Open the door.
- 2) Remove the choke cover cap very carefully with a flat-blade screwdriver.

**CAUTION : Be careful not to damage door seal plate by screwdriver.**

- 3) Lift up and push the door.

### NOTE:

1. After replacing the door, be sure to check that the primary switch, monitor switch, and secondary switch operate normally.
2. After replacing the door, check for microwave energy leakage with a survey meter. Microwave energy must be below the limit of 5 mW/cm. (with a 275 ml water load)
3. When mounting the door assembly to the oven assembly, be sure to adjust the door assembly parallel to the chassis. Also adjust so the door has no play between the inner door surface and oven frame assembly. If the door assembly is not mounted properly, microwaves may leak from the clearance between the door and the oven.

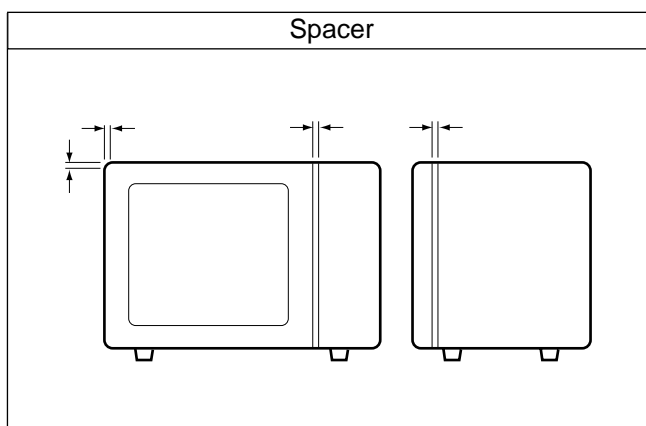
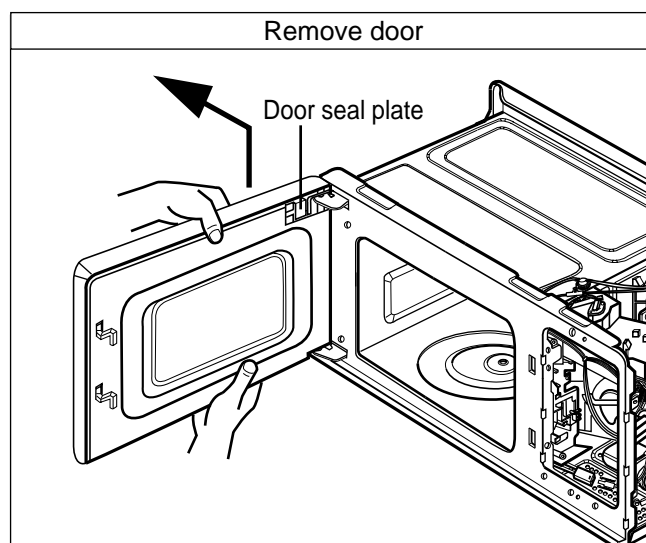
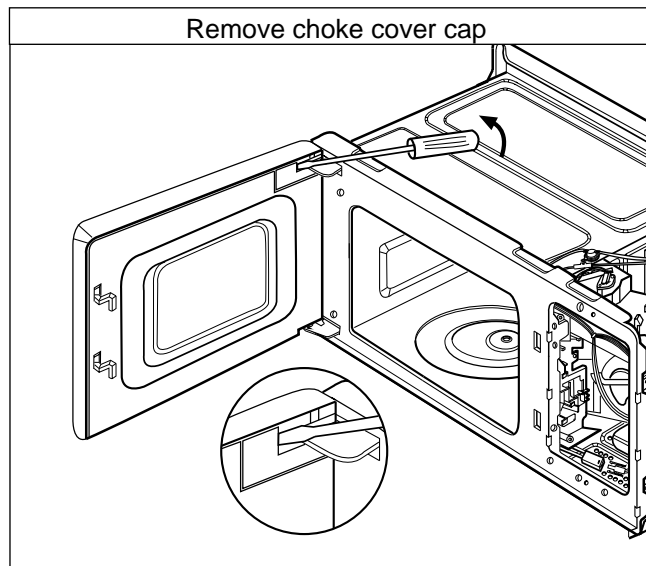

## F. HIGH VOLTAGE TRANSFORMER

### REMOVAL

- 1) Discharge the high voltage capacitor.
- 2) Disconnect the leadwire from magnetron, high voltage transformer, and capacitor.
- 3) Remove the screw holding the high voltage transformer to the baseplate.

## G. FAN MOTOR ASSEMBLY REMOVAL

- 1) Discharge the high voltage capacitor.
- 2) Disconnect the leadwire from fan motor, and high voltage capacitor.
- 3) Remove the two screws holding the suction guide ASS'Y to the oven cavity and remove the high voltage diode earth screw.
- 4) Remove the two screws holding the fan motor ASS'Y to the suction guide ASS'Y.

## H. HIGH VOLTAGE CAPACITOR AND DIODE REMOVAL

- 1) Discharge the high voltage capacitor.
- 2) Disconnect the leadwire from fan motor, and high voltage capacitor.
- 3) Remove the screw holding the suction guide ASS'Y to the oven cavity and remove the high voltage diode earth screw.
- 4) Remove the screw holding the high voltage capacitor bracket.

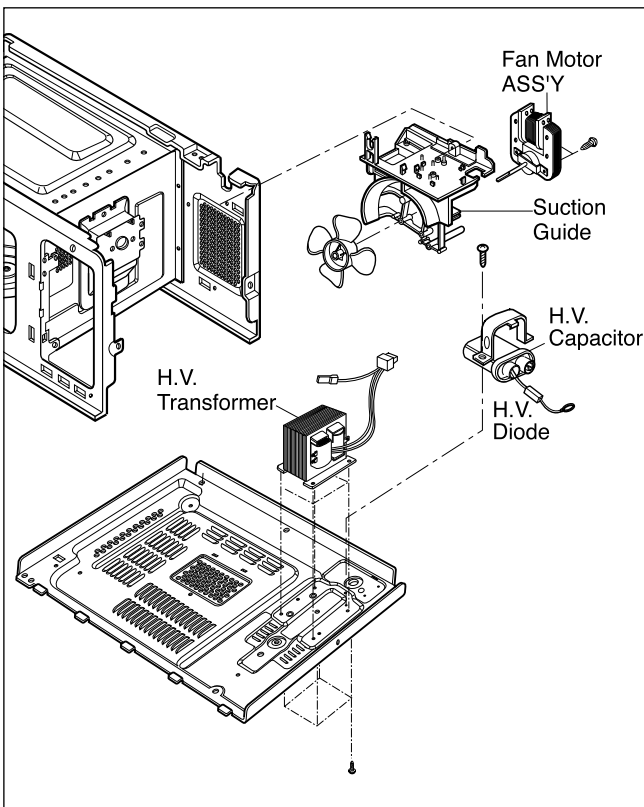

## I. AIR DUCT ASSEMBLY REMOVAL

- 1) Disconnect the leadwire from lamp.
- 2) Remove the mounting screw to Latch Board.

## J. MAGNETRON REMOVAL

- 1) Disconnect the leadwire from the high voltage transformer.
- 2) Carefully remove the mounting screws holding the magnetron to the waveguide.
- 3) Remove the magnetron ASS'Y until the tube is clear from the waveguide.

### NOTE:

1. When removing the magnetron, make sure its dome does not hit any adjacent parts, or it may be damaged.
2. When replacing the magnetron, be sure to install the magnetron gasket in the correct position and be sure that the gasket is in good condition.
3. After replacing the magnetron, check for microwave leakage with a survey meter around the magnetron. Microwave energy must be below the limit of 5 mW/cm<sup>2</sup>. (With a 275 ml. water load).  
**Make sure that gasket is rigidly attached to the magnetron.** To prevent microwave leakage, tighten the mounting screws properly, making sure there is no gap between the waveguide and the magnetron.

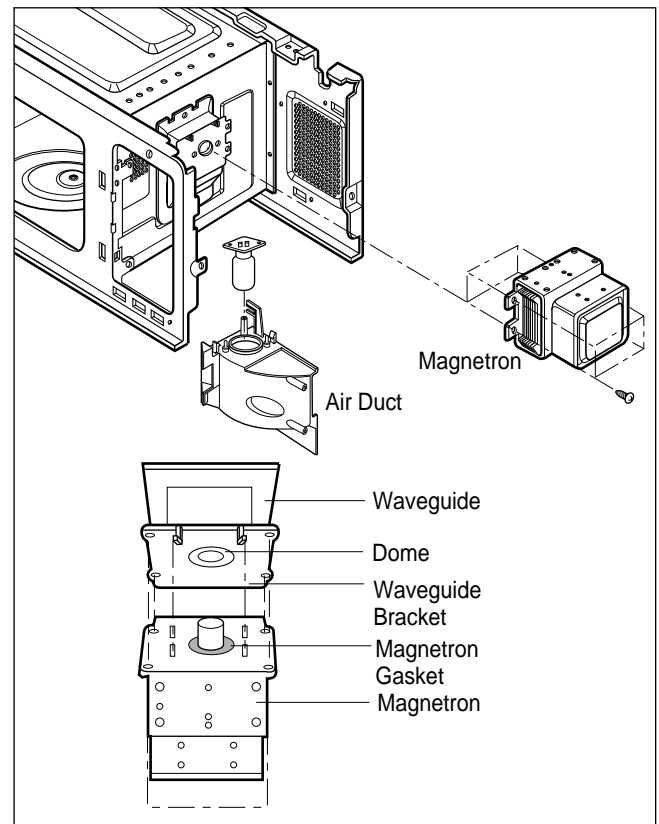

## K. REMOVING THE TURNTABLE MOTOR

- 1) Remove the turntable.
- 2) Remove the turntable shaft VERY CAREFULLY with a slotted screwdriver.
- 3) Lay the unit down on its back.
- 4) Remove the turntable motor cover.  
The turntable base cover is easily removed by pinching the six parts with a wire cutting.
- 5) Disconnect the leadwire from the turntable motor terminals.
- 6) Remove the screw securing the turntable motor to the oven cavity ASS'Y
- 7) After repairing the motor, rotate the removed turntable motor cover.
- 8) Fit the turntable motor cover's projecting part to the base plate slit.

### NOTE:

1. Remove the wire lead from the turntable motor VERY CAREFULLY.
2. Be sure to grasp the connector, not the wires, when removing.

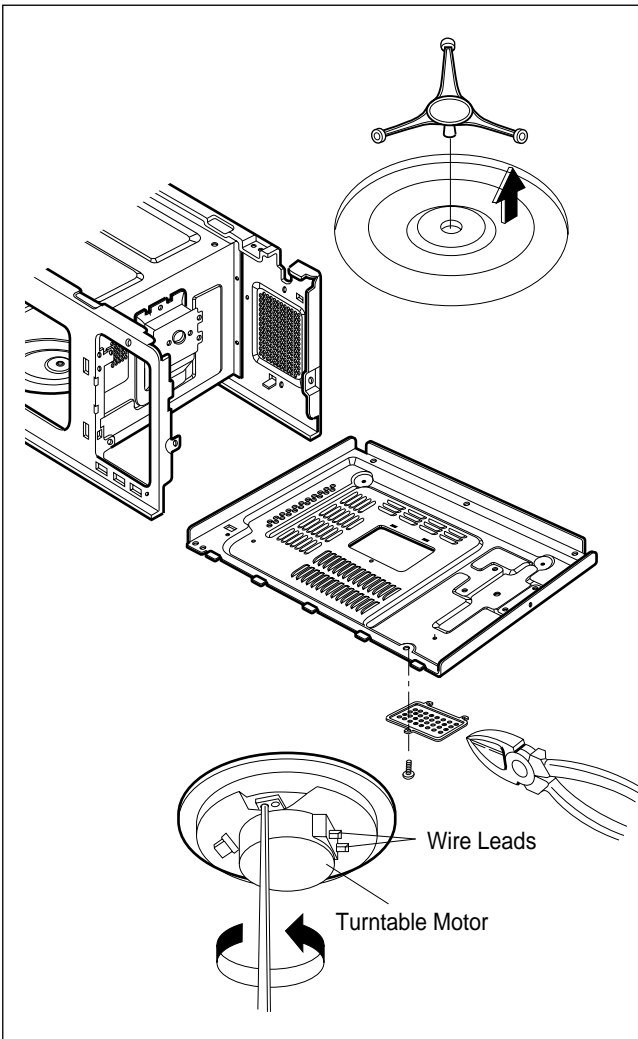

## L. INTERLOCK SYSTEM

### 1) INTERLOCK MECHANISM

The door lock mechanism is a device which has been specially designed to eliminate completely microwave activity when the door is opened during cooking and thus to prevent the danger resulting from the microwave leakage.

### 2) MOUNTING OF THE PRIMARY/MONITOR/SECONDARY SWITCHES TO THE LATCH BOARD

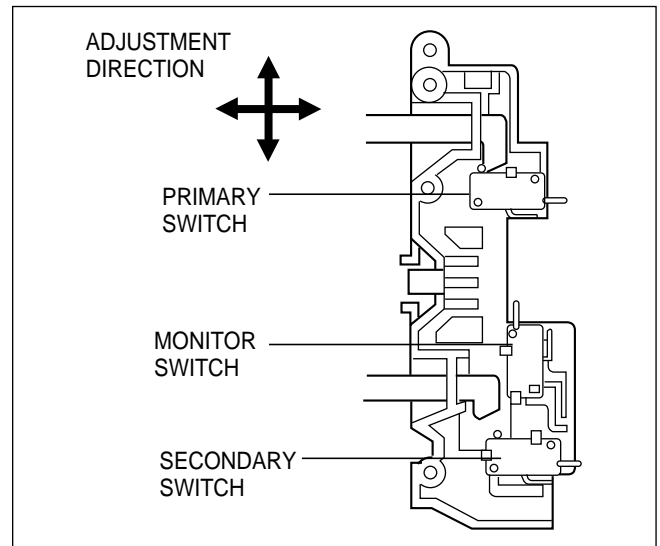

### 3) INSTALLATION AND ADJUSTMENT OF THE LATCH BOARD TO THE OVEN ASSEMBLY

- Mount the latch board to the oven assembly.
- Adjust the latch board in the arrow direction so that oven door will not have any play in it when the door is closed.
- Tighten the mounting screw.
- **Check for play in the door by pushing the door release button. Door movement should be less than 0.5 mm. (1/64 inch)**

Don't push the door release button while making adjustment. Make sure that the latch moves smoothly after adjustment are completed and that the screws are tight. Make sure the primary, monitor, and secondary switches operate properly by following the continuity test procedure.



# INTERLOCK CONTINUITY TEST

**WARNING : FOR CONTINUED PROTECTION AGAINST EXCESSIVE RADIATION EMISSION, REPLACE ONLY WITH IDENTICAL REPLACEMENT PARTS.**

TYPE NO. SZM-V 16-FA-63 OR VP-533A-OF FOR PRIMARY SWITCH  
 TYPE NO. SZM-V 16-FA-62 OR VP-532A-OF FOR MONITOR SWITCH  
 TYPE NO. SZM-V 16-FA-63 OR VP-533A-OF FOR SECONDARY SWITCH

## A. PRIMARY INTERLOCK SWITCH TEST

When the door release button is depressed slowly with the door closed, an audible **click** should be heard at the same time or successively at intervals. When the button is released slowly, the latches should activate the switches with an audible **click**.

If the latches do not activate the switches when the door is closed, the switches should be adjusted in accordance with the adjustment procedure. Disconnect the wire lead from the primary switch. Connect the ohmmeter leads to the common (COM) and normally open (NO) terminal of the switch. The meter should indicate an open circuit in the door open condition. When the door is closed, the meter should indicate a closed circuit.

When the primary switch operation is abnormal, make the necessary adjustment or replace the switch only with the same type of switch.

## B. SECONDARY INTERLOCK SWITCH TEST

Disconnect the wire lead from the secondary switch. Connect the ohmmeter leads to the common (COM) and normally open (NO) terminals of the switch. The meter should indicate a open circuit in the door open condition. When the door is closed, meter should indicate an closed circuit. When the secondary switch operation is abnormal, make the necessary adjustment or replace the switch only with the same type of switch.

## C. MONITOR SWITCH TEST

Disconnect the wire lead from the monitor switch. Connect the ohmmeter leads to the common (COM) and normally closed (NC) terminals of the switch. The meter should indicate closed circuit in the door open condition. When the door is closed, meter should indicate an open circuit. When the monitor switch operation is abnormal, replace with the same type of switch.

**NOTE: After repairing the door or the interlock system, it is necessary to do this continuity test before operating the oven.**

COMPONENTS	TEST PROCEDURE	RESULTS	
		Door open	Door closed
SWITCHES (Wire leads removed)	Check for continuity of the switch with an Ohm-meter		
	Primary Switch		
	Monitor Switch		
	Secondary Switch		
NOTE : After checking for the continuity of switches, make sure that they are connected correctly.			



# COMPONENT TEST PROCEDURE

## CAUTIONS

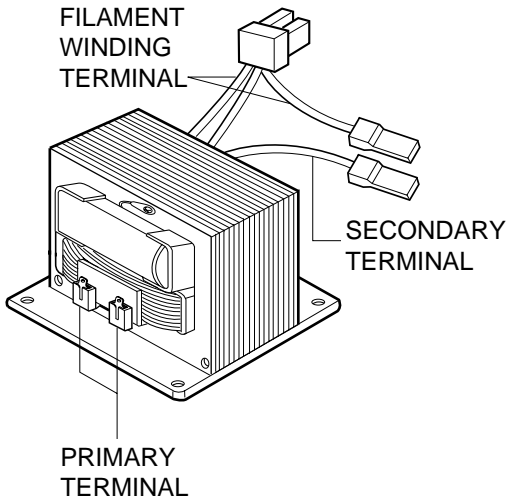
1. DISCONNECT THE POWER SUPPLY CORD FROM THE OUTLET WHENEVER REMOVING THE OUTER CASE FROM THE UNIT. PROCEED WITH THE TEST ONLY AFTER DISCHARGING THE HIGH VOLTAGE CAPACITOR AND REMOVING THE WIRE LEADS FROM THE PRIMARY WINDING OF THE HIGH VOLTAGE TRANSFORMER. (SEE PAGE 2-1)
2. ALL OPERATIONAL CHECKS WITH MICROWAVE ENERGY MUST BE DONE WITH A LOAD (1 LITER OF WATER IN CONTAINER) IN THE OVEN.

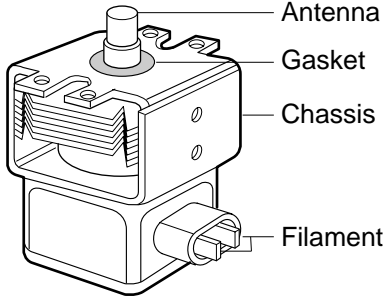
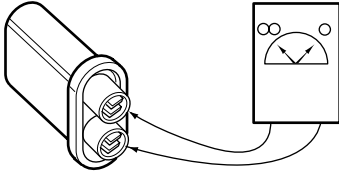
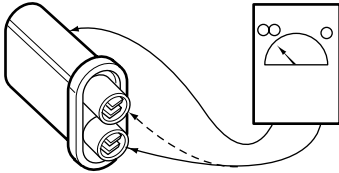
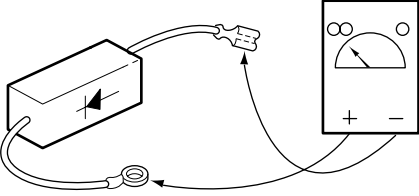
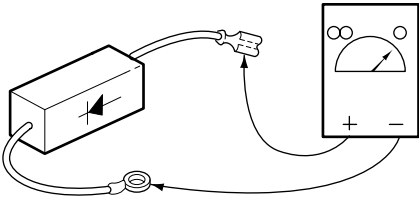
COMPONENTS	TEST PROCEDURE	RESULTS
<p>HIGH VOLTAGE TRANSFORMER (Wire leads removed)</p>	 <p>1. Measure the resistance. (Ohm-meter scale: Rx1 and Rx100)</p> <ul style="list-style-type: none"> <li>• Primary winding</li> <li>• Secondary winding</li> <li>• Filament winding</li> </ul> <p>2. Measure the resistance. (Ohm-meter scale: Rx1000)</p> <ul style="list-style-type: none"> <li>• Primary winding to ground</li> <li>• Filament winding to ground</li> </ul>	<p>Approx.: 0.3 ~ 0.8 ohm Approx.: 100 ~ 200 ohm Less than: 1 ohm</p> <p>Normal: Infinite Normal: Infinite</p>
<p>MAGNETRON (Wire leads removed)</p>	<p>1. Measure the resistance. (Ohm-meter scale: Rx1)</p> <ul style="list-style-type: none"> <li>• Filament terminal</li> </ul> <p>2. Measure the resistance. (Ohm-meter scale: Rx1000)</p> <ul style="list-style-type: none"> <li>• Filament to chassis</li> </ul>	<p>Normal: Less than 1 ohm</p> <p>Normal: Infinite</p>

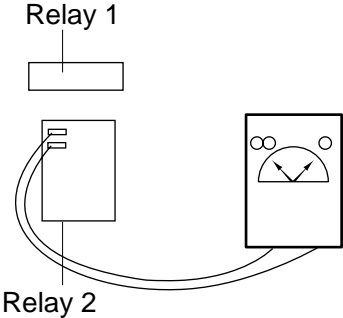
COMPONENTS	TEST PROCEDURE	RESULTS
	 <p>NOTE: When testing the magnetron, be sure to install the magnetron gasket in the correct position and be sure that the gasket is in good condition.</p>	
HIGH VOLTAGE CAPACITOR	<p>Measure the resistance. (Ohm-meter scale: Rx1000)</p> <ul style="list-style-type: none"> <li>• Terminal to terminal.</li> </ul> 	Normal: Momentarily indicates several ohms, and then gradually returns to infinite.
	<p>Measure the resistance. (Ohm-meter scale: Rx1000)</p> <ul style="list-style-type: none"> <li>• Terminal to case.</li> </ul> 	Normal: Infinite.
HIGH VOLTAGE DIODE	<p>Measure the continuity (Forward). (Ohm-meter scale: Rx10000)</p> 	Normal: Continuity. Abnormal: Infinite.
NOTE : Some inexpensive meters may indicate infinite resistance in both direction.	<p>Measure the continuity (Reverse). (Ohm-meter scale: Rx10000)</p> 	Normal: Infinite. Abnormal: Continuity.

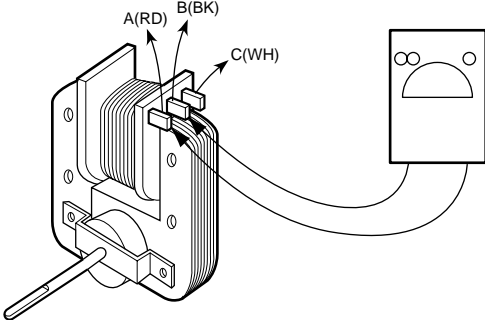
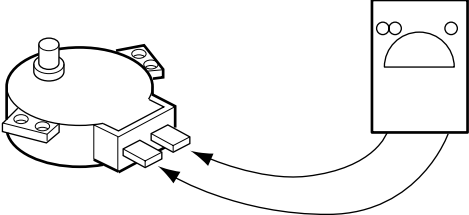
COMPONENTS	TEST PROCEDURE	RESULTS		
RELAY 2	<p>Check for continuity of relay 2 with an ohm-meter. (Remove wire leads from relay 2 and operate the unit.)</p> 	POWER LEVEL		
FAN MOTOR (Wire leads removed)	<p>Measure the resistance. (Ohm-meter scale: R x 100)</p> 	<p>Normal: A~B : Approx. 65 ~ 80 ohm B~C : Approx. 10 ~ 30 ohm A~C : Approx. 85 ~ 105 ohm</p> <p>Abnormal: Infinite or several ohm.</p>		
TURNTABLE MOTOR (Wire leads removed)	<p>Measure the resistance. (Ohm-meter scale: R x 1000)</p> 	<p>Normal: Approx. 100 ~ 150 ohm Abnormal: Infinite or several ohm.</p>		
<p>NOTE : • A MICROWAVE LEAKAGE TEST MUST ALWAYS BE PERFORMED WHEN THE UNIT IS SERVICED FOR ANY REASON. • MAKE SURE THE WIRE LEADS ARE IN THE CORRECT POSITION. • WHEN REMOVING THE WIRE LEADS FROM THE PARTS, BE SURE TO GRASP THE CONNECTOR, NOT THE WIRES.</p>				

# TROUBLE SHOOTING

WHEN YOU GET A COMPLAINT FROM YOUR CUSTOMER, EVALUATE THE COMPLAINT CAREFULLY. IF THE FOLLOWING SYMPTOMS APPLY, PLEASE INSTRUCT THE CUSTOMER IN THE PROPER USE OF THE MICROWAVE OVEN. THIS CAN ELIMINATE AN UNNECESSARY SERVICE CALL.

## CAUTIONS

1. Check grounding before checking for trouble.
2. Be careful of the high voltage circuit.
3. Discharge the high voltage capacitor. (See page 2-1)
4. When checking the continuity of the switches or of the high voltage transformer, disconnect one lead wire from these parts and then check continuity with the AC plug removed. To do otherwise may result in a false reading or damage to your meter.

CONDITION	CAUSE	REMEDY
Microwave oven does not work.	Inserting many plug into one plug outlet and using them at the same time (blown fuse or breaker)	Avoid using other electrical appliances when you use the microwave oven.
	Microwave oven plug is not inserted tightly.	Insert microwave oven plug securely.
Output power is too low.	Low AC input voltage.	Use the microwave oven at adequate line voltage.
	Food temperature is too low.	This may not be a defect. It is possible that the food should be cooked for a longer time period.
Sparks occur.	Using metallic ware and allowing it to touch the oven wall.	Do not use metallic ware for cooking except where noted in the cooking guide.
	Ceramic ware trimmed in gold or silver powder is used.	Do not use any type of cookware with metallic trimming.
Uneven cooking.	Inconsistent intensity of microwave by their characteristics.	<ol style="list-style-type: none"> <li>1. Use plastic wrap or lid.</li> <li>2. Stir once or twice while cooking soup, cocoa or milk, etc.</li> </ol>

**(TROUBLE 2) Oven does not operate at all, Display window does not display any figures, and no input is accepted.**

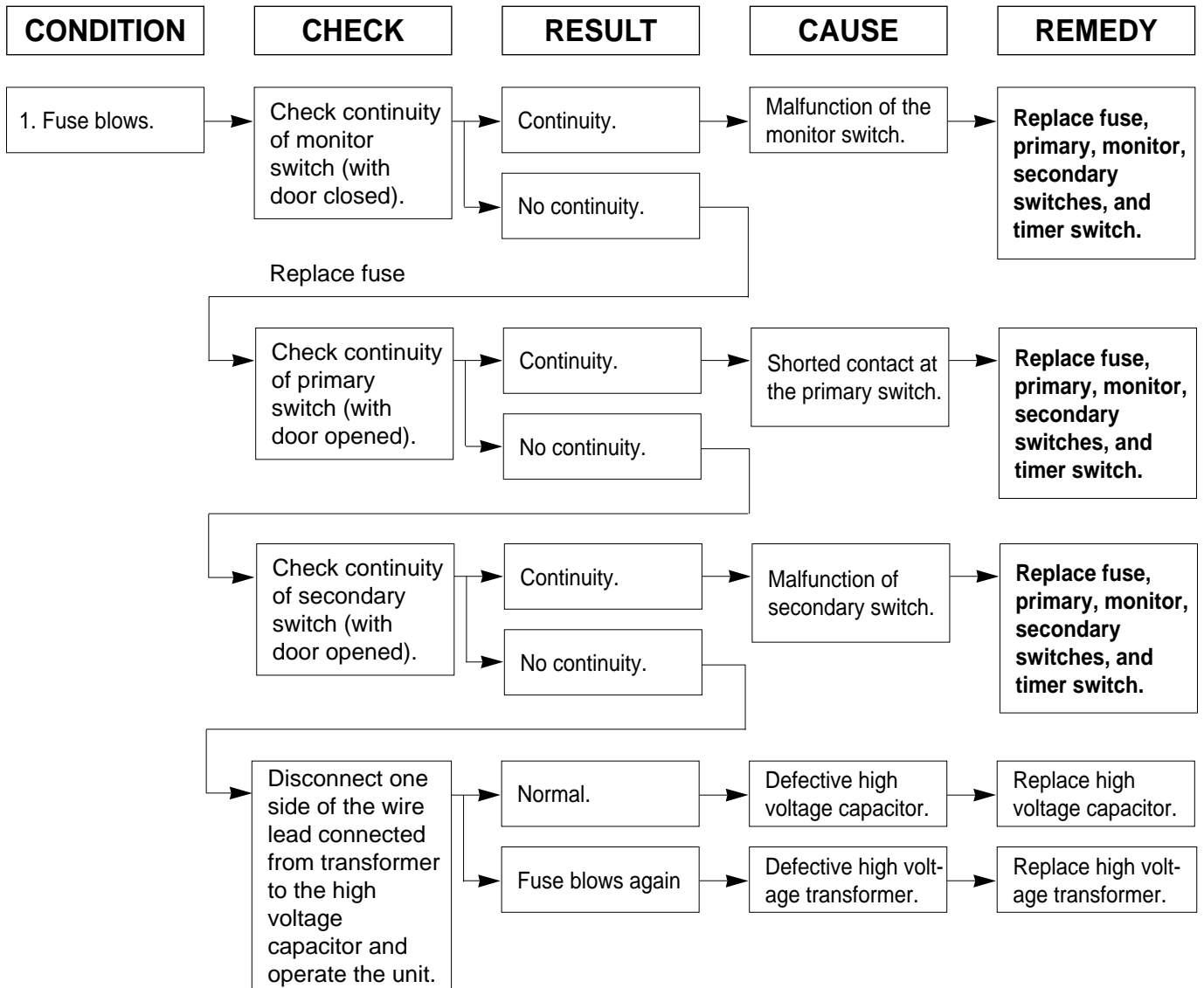

**NOTE : All these switches must be replaced at the same time. Refer to page 5-8**

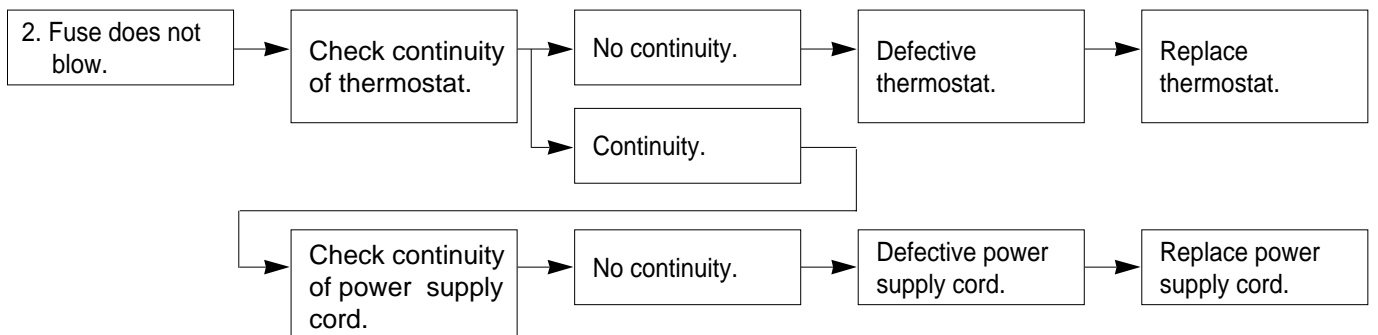

**(TROUBLE 2) Oven seems to be operating but little heat is produced in oven load.**

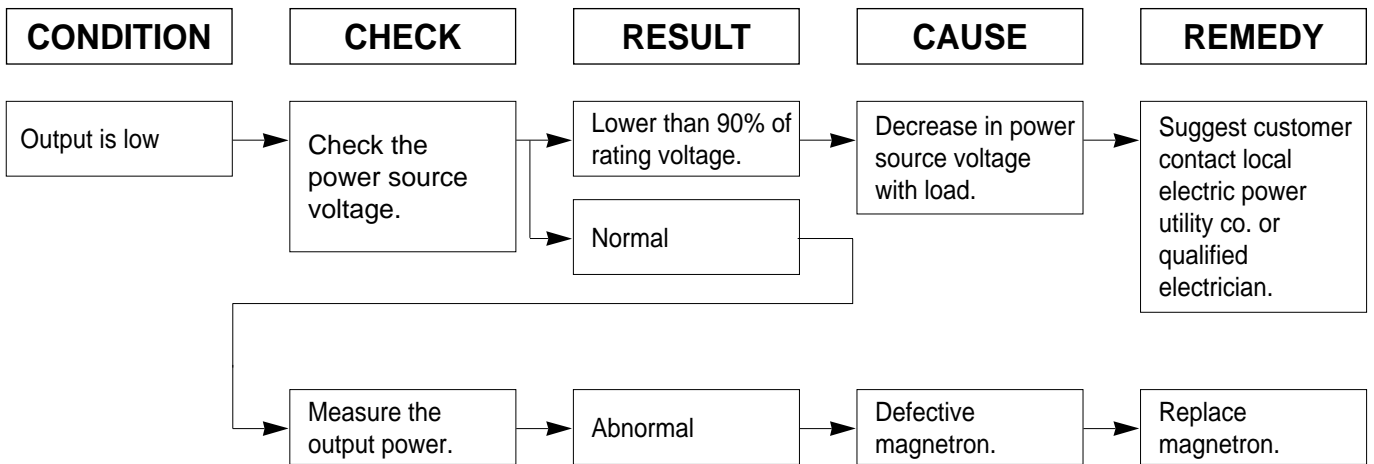

**NOTE :** Simple test of power output-conducted by heating one liter water for one min. if available.  
 Minimum 8.5°C temperature rise is normal condition.

**(TROUBLE 3) No microwave oscillation even though oven lamp and fan motor run.**

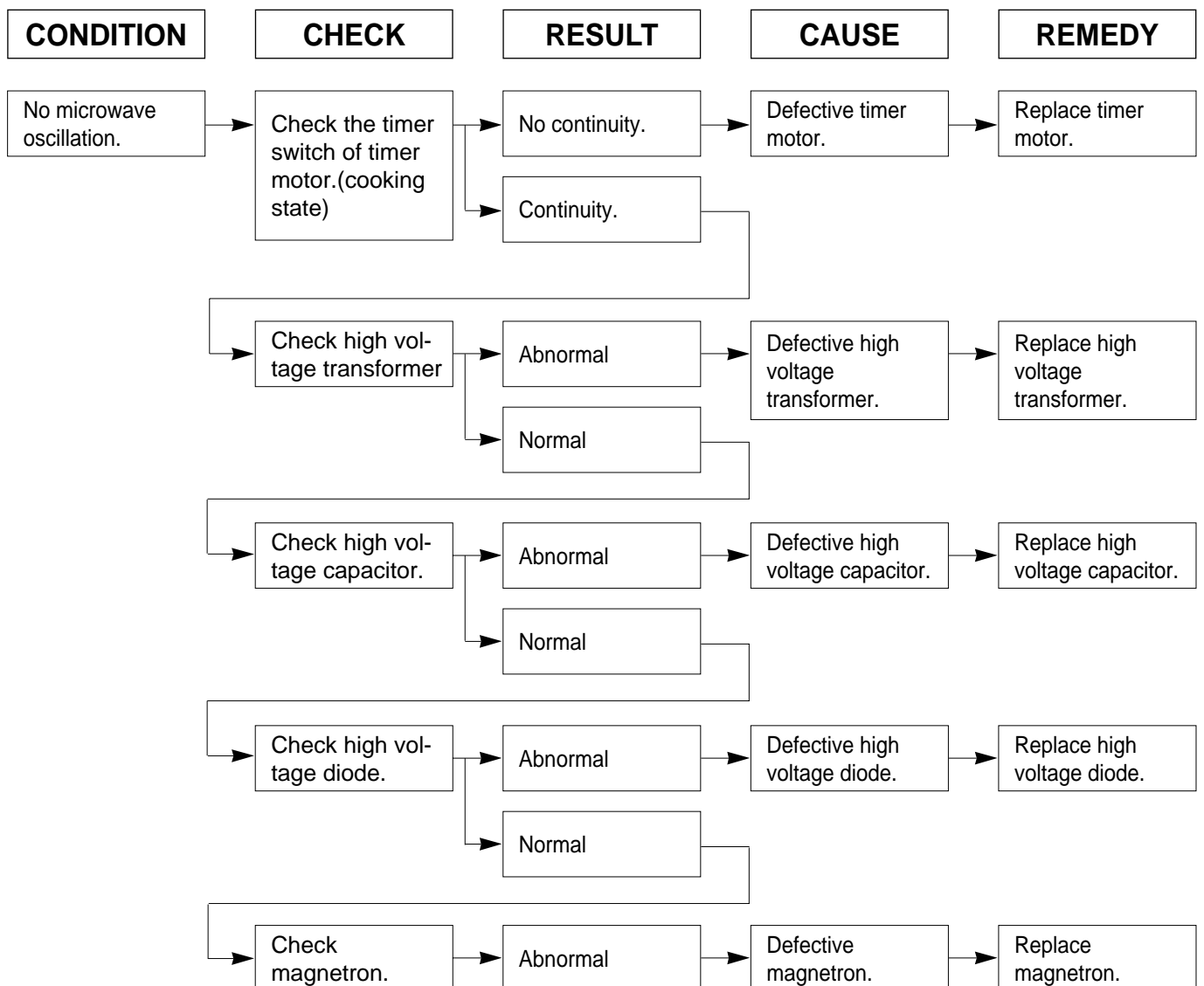

**NOTE :** • Make sure the wire leads are in the correct position.

- When removing the wire leads from the parts, be sure to grasp the connector, not the wires.
- When removing the magnetron, be sure to install the magnetron gasket in the correct position and in good condition.



# EXPLODED VIEW

## INTRODUCTION

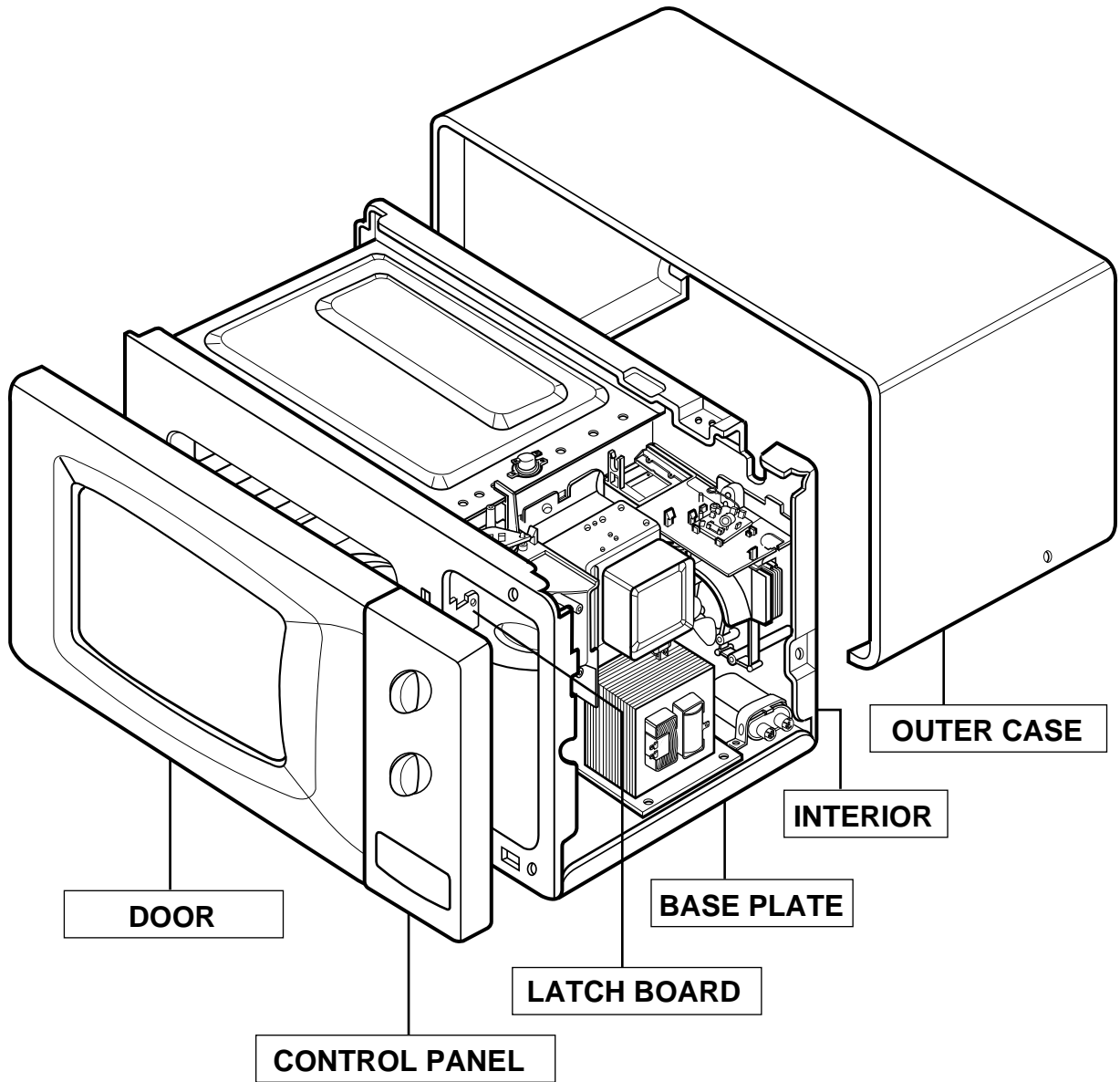

# DOOR PARTS

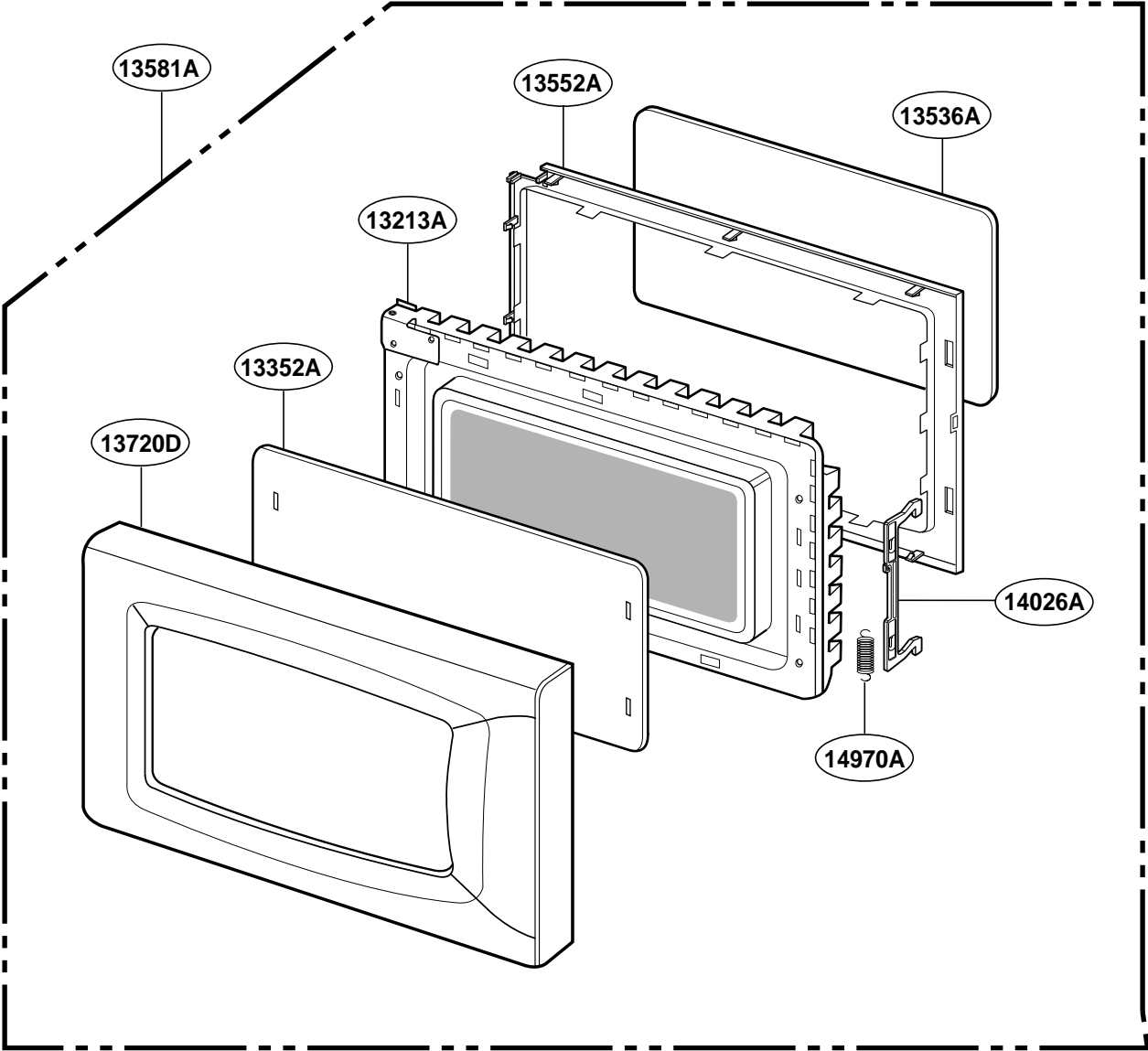

# CONTROL PANEL PARTS

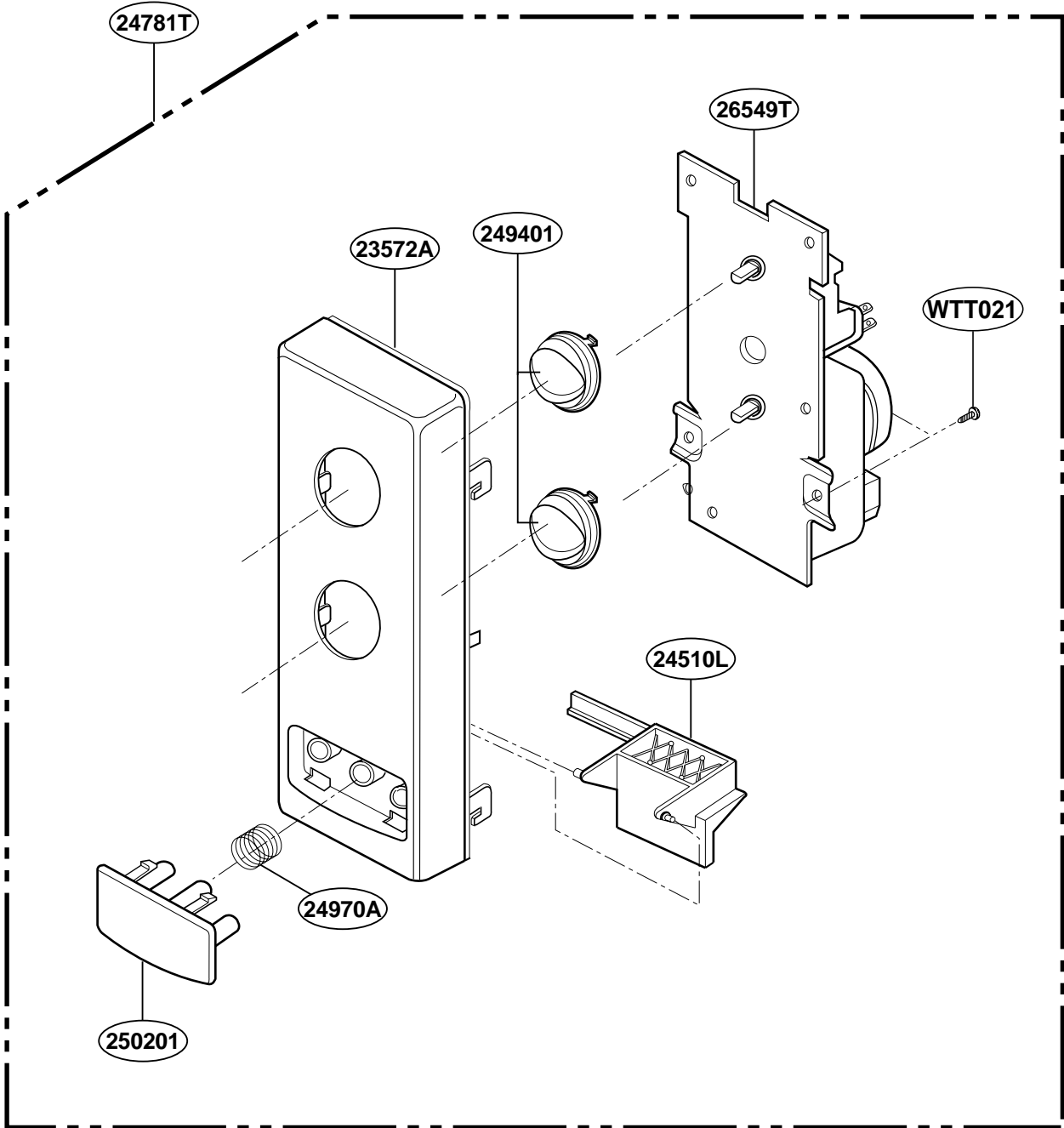

# OVEN CAVITY PARTS

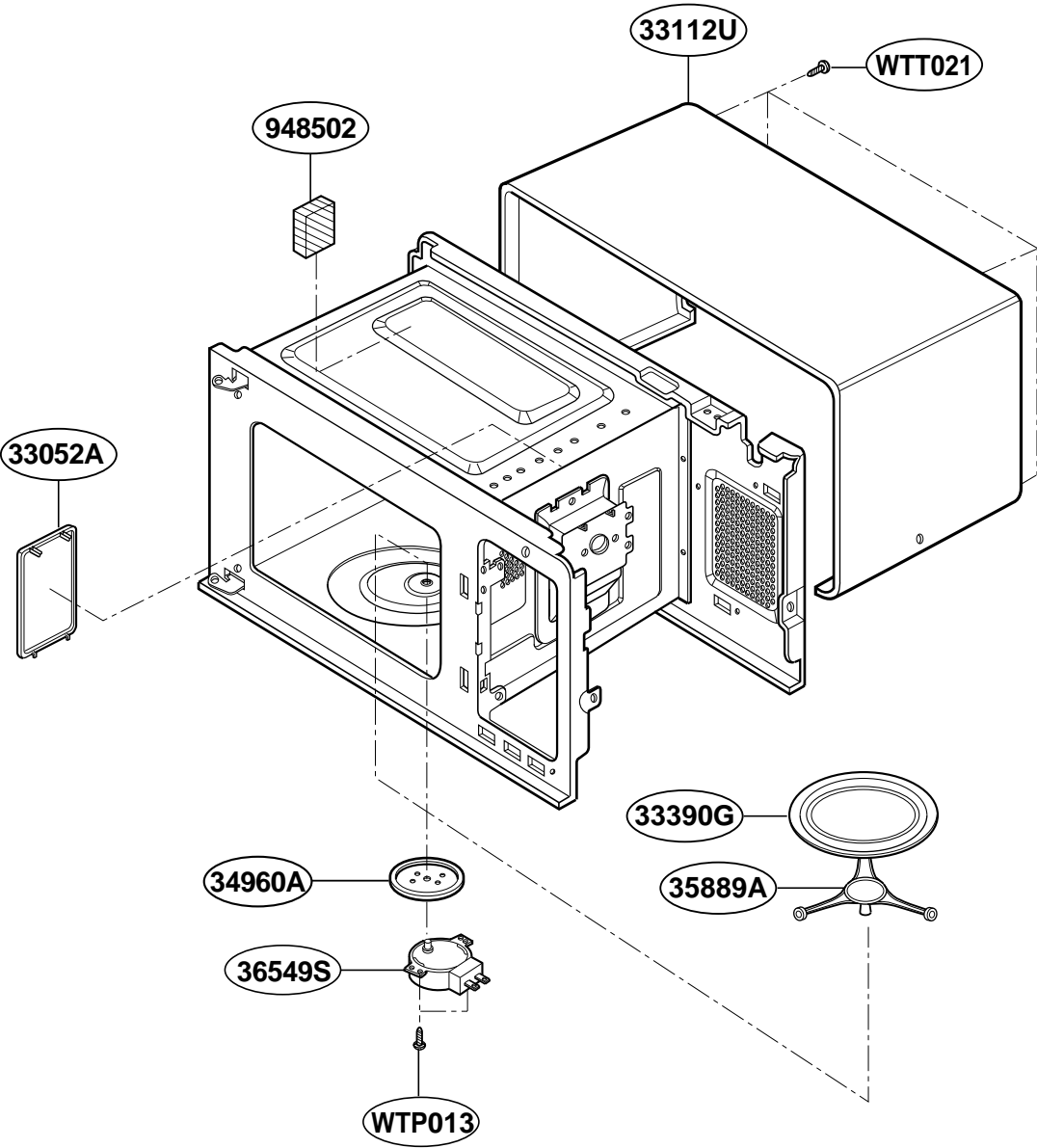

# SUCTION GUIDE PARTS

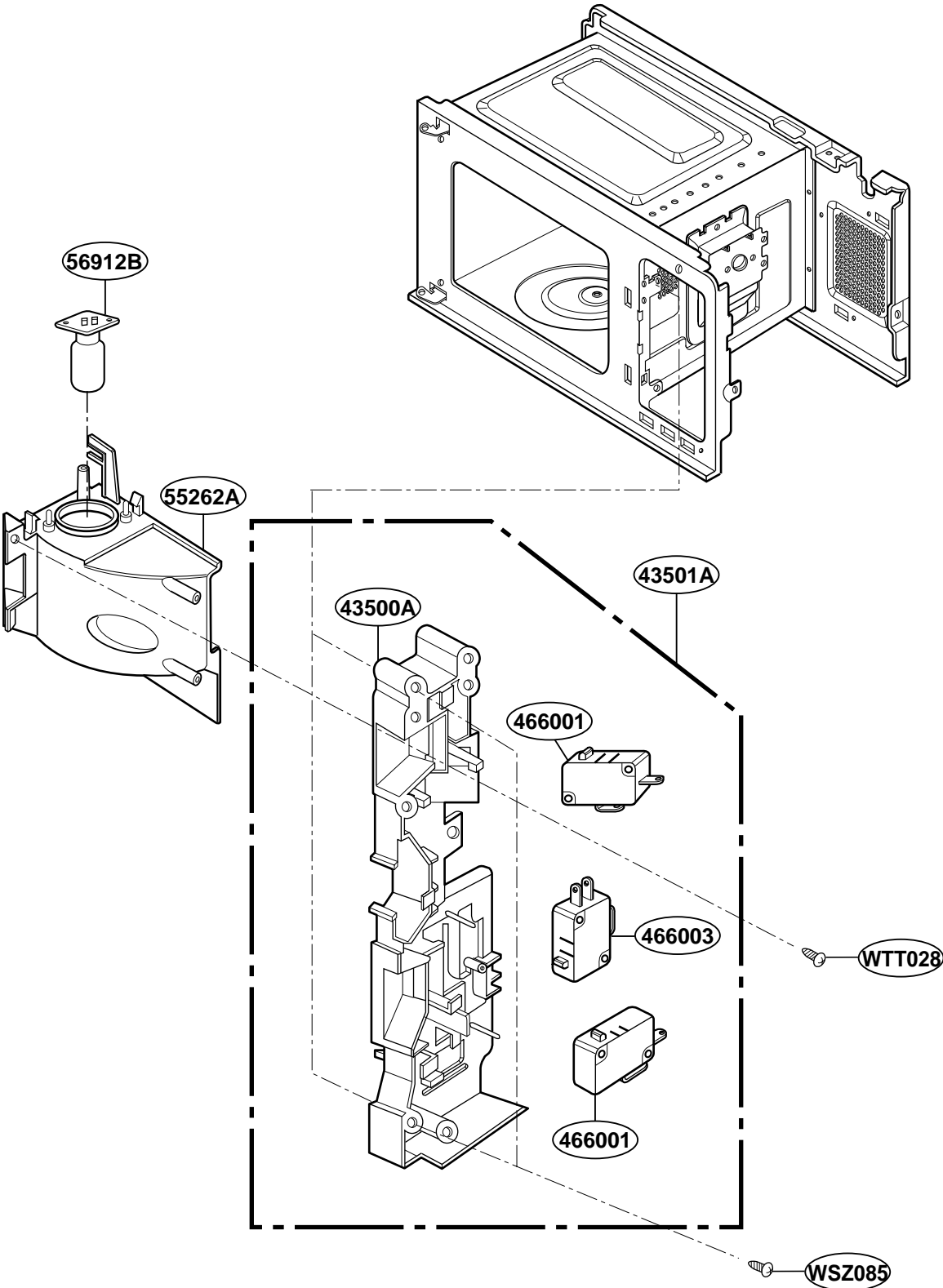

# INTERIOR PARTS

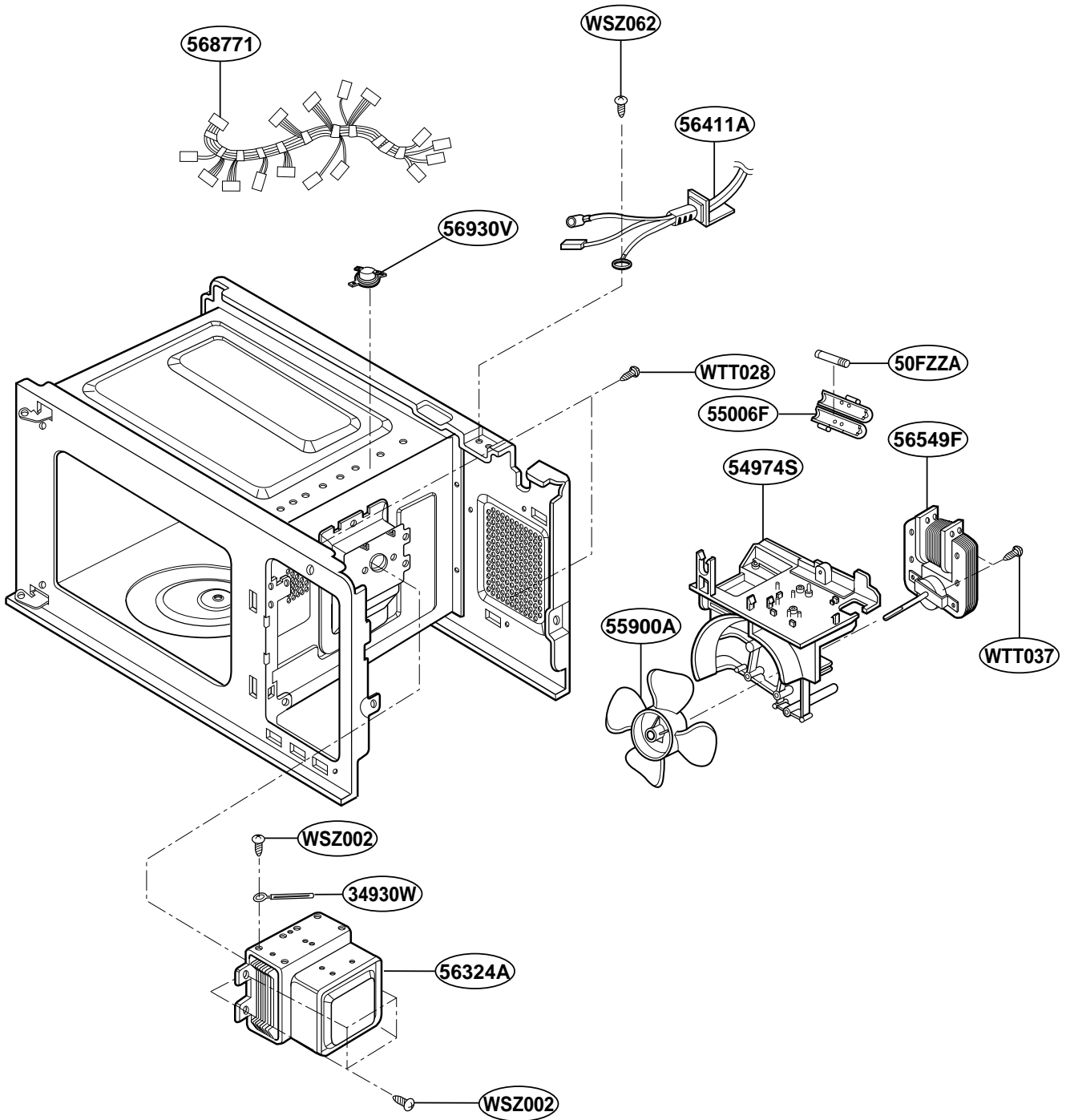

# BASE PLATE PARTS

