

---

**Friedrich**

# C-90A Electronic Air Cleaner



**Service Information**

# Table of Contents

## Page

Friedrich Electronic Air Cleaner .....	3
Specifications .....	3
CAUTION - Before Operation .....	4
Operating Your Friedrich Air Cleaner .....	4
How Electronic Air Cleaners Work .....	5
Cleaning	
Important Precautions .....	5
Cleaning the Pre-Filter .....	5
Cleaning the Carbon Filter .....	5
Cleaning the Electronic Cell .....	6
Alternate Cell Cleaning Method .....	6
Discoloration of the Cell .....	6
Replacing the Cell in Cabinet .....	7
Activated Carbon Filter .....	7
Consumer Troubleshooting Guide .....	7
Troubleshooting Electronic Air Cleaner .....	8
Wiring Schematic .....	9
Major Components .....	10
C-90A Electronic Air Cleaner Component Parts List .....	11
Authorized Warranty Repair Stations .....	12

# Friedrich Electronic Air Cleaner



The Friedrich Electronic Air Cleaner is a self-contained console model consisting of a high voltage DC power supply, electronic cell, 3 speed fan, pre-filter and activated carbon post-filter in a rugged plastic cabinet.

It is designed to remove dust, tobacco smoke, pollen, bacteria, and other airborne contaminants from the air. In just minutes, you will notice improvements in your indoor air quality as your Friedrich air cleaner begins the job of removing the billions of irritating microscopic particles from your home or office. The activated carbon post-filter also helps eliminate many objectionable indoor odors.

## Specifications

### MODEL C-90A

#### OPERATING TEMPERATURES

This air cleaner is intended for use at temperatures normally found in occupied spaces.

#### ELECTRICAL RATINGS

115 Volt, 60 Hertz.

#### INDICATOR LIGHT

Located on the access cover next to 3-speed switch. Indicates air cleaner operating properly.

#### INTERLOCK SWITCH

Interrupts supply power to unit when access cover is opened.

#### WEIGHT

35 lbs. shipping weight  
30 lbs. net weight

#### DIMENSIONS

	Height	Width	Depth
Cabinet	19"	15"	21 1/2"
Cell	16"	12 1/2"	4 1/2"
Pre-Filter	15 7/8"	12 3/4"	1/4"
Carbon Filter	15 7/8"	12 3/4"	1/4"

#### NOMINAL CURRENT AND POWER CONSUMPTION

Power Supply	120 Volt, 60 Hertz		
	CFM	Amps	Watts
High Speed	410	.78	99
Medium Speed	340	.56	64
Low Speed	280	.41	47

# CAUTION - before operation . . .

- Remove the plastic cover from the activated carbon filter and install in unit.
- Position the pre-filter at the rear of the unit (closest to the electronic cell) and the carbon filter at the front (side air comes out.)
- Make sure the electronic cell is properly placed in the cabinet - airflow arrow on the end plate should be pointing toward the fan.
- Make sure that the top cover is securely in place.
- This unit is equipped with a grounded plug for your protection against shock hazards and should be plugged directly into a properly grounded receptacle.
- Electronic air cleaners should NOT be placed in any area where potentially explosive gases or vapors exist, nor should they be used in wet environments.

## Operating your Friedrich air cleaner

### CONTROLS

All controls for the Friedrich electronic air cleaner are located on the top of the unit and are accessible through an opening in the top cover. The controls are OFF - HI -MED - LOW. Plus, an indicator lamp shows when the cleaner is on and operating normally.

Generally, HIGH fan speed is used in extreme conditions for rapid cleaning, such as after a party where there were many smokers; or for large areas where HIGH fan is required to circulate the clean air into all areas of the room. MEDIUM and LOW settings are usually adequate to maintain a clean air environment.

At initial start-up, the indicator lamp may flicker on and off and is no cause for alarm. Should the lamp completely fail to come on, review BEFORE OPERATING and TROUBLESHOOTING sections.

During the initial use, "snapping" sounds may be heard. This is normal and the unit may continue to make these noises the first few days of operation. After the initial break-in period, only an occasional "snap" will be heard, indicating the unit is cleaning your air. **NOTE: As the air cleaner electronic cell becomes dirty, it will "snap" more frequently. When this occurs, you should consider washing the cell.**

### LOCATION

The best location is a position closest to the concentration of tobacco smoke or dust producing activities.

Position the unit so that the airflow around the intake and discharge grilles is not blocked. For best results, do not place the intake grille (rear) closer than 18 cm (8") from a wall. Provide a clear, unobstructed path for the discharge air. The farther the discharge air travels, the greater the effectiveness of the air cleaner. For greater comfort, position the air cleaner so that the discharge air does not cause uncomfortable drafts.

To use a room air cleaner most effectively in rooms that share an open doorway or archway, position the unit near the common opening and direct the airflow into the adjacent room to promote good air circulation.

### ECONOMICAL CLEAN AIR

The Friedrich electronic air cleaner costs no more to operate than a standard household light bulb. The benefits from clean air far outweigh the low operating costs of continuous cleaning. Remember, the more you operate your electronic air cleaner, the cleaner your air will be.

# How electronic air cleaners work

Electronic air cleaners are an extremely efficient, cost effective method of removing indoor air contaminants. Unlike standard media that merely block relatively large particles, electronic air cleaners attract and hold particles so small that an electron microscope is needed to see them.

- 1** The **PRE-FILTER** catches lint, hair and large dust particles, as room air is drawn in through the rear grille by the powerful **3-SPEED FAN**.
- 2** In the **IONIZING SECTION** of the **ELECTRONIC CELL**, billions of microscopic particles, too small to be caught by the pre-filter, become electronically charged as they pass through a powerful electric field.
- 3** **COLLECTOR PLATES** immediately attract and hold these "charged" particles much like metal filings are attracted to a powerful magnet. The accumulated particles are permanently removed from the air and cling to the metal plates until washed off.
- 4** Finally, an **ACTIVATED CARBON FILTER** removes most household odors and fumes as the clean air is circulated back into the room.

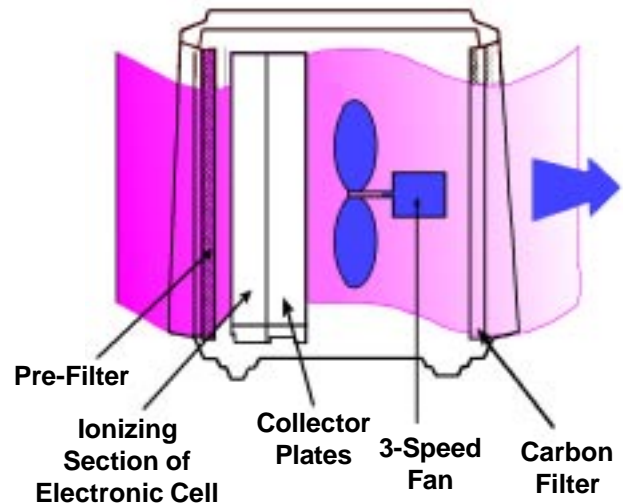

## Cleaning

### IMPORTANT PRECAUTIONS

Turn off air cleaner before opening top cover to remove electronic cell and pre-filter for cleaning. Always be careful when handling the electronic cell. Sharp edges and wires are capable of inflicting wounds. Care should also be taken when cleaning because of extremely hot water and potentially harmful effects of detergents on your skin.

The collector plates of the electronic cell and the pre-filter can become extremely dirty. With an excessive amount of contamination buildup on the collector plates and the pre-filter, the electronic air filter's efficiency decreases. Also, as dirt builds up on the ionizing wires, the charge process becomes less efficient.

To prevent this loss of efficiency, the electronic cell and pre-filter must be cleaned regularly. How often will depend on actual usage. Cleaning will be more frequent if the air cleaner is operated continuously or under severe conditions.

### CLEANING THE PRE-FILTER

Remove the pre-filter and shake out or brush off the accumulated dust and lint. If this is not adequate, a vacuum may be used or the pre-filter can be cleaned with an all purpose alkaline detergent based cleaner to remove tobacco smoke and cooking grease stains. A thorough rinsing is required after each cleaning.

After cleaning, allow to dry and reinsert.

### CLEANING THE CARBON FILTER

Occasionally, the carbon filter will need cleaning. Use a stream of air or a vacuum to remove the dirt. THE CHEMICAL AND ODOR ABSORPTION CAPABILITIES CAN NOT BE RESTORED. When the carbon filter can no longer remove odors from the air, it must be replaced (Friedrich part number 616-420-00). THE CARBON FILTER MUST BE IN PLACE FOR THE AIR CLEANER TO OPERATE.

# Cleaning (Cont.)

## CLEANING THE ELECTRONIC CELL

The simplest method of cleaning the electronic cell is to use an automatic dishwasher. The dishwasher provides the correct cycle of wash, rinse and dry. Water temperatures normally found in dishwashers 150°F to 170°F will not harm the cell.

1. After turning off the air cleaner, remove the cell and gently place on dishwasher rack with airflow arrows pointing up. In some dishwashers, it may be necessary to remove the top rack. **BE EXTREMELY CAREFUL WHEN PLACING ON DISHWASHER RACK TO NOT DAMAGE IONIZER WIRES OR BEND COLLECTOR PLATES.**
2. Use any available household dishwasher detergent recommended for use in your appliance and follow manufacturer's instructions.
3. Not all dishwashers may be capable of holding the electronic cell. Be sure to compare the internal size of the dishwasher to the dimensions of the electronic cell: 16" high x 12 1/2" wide x 4 1/2" deep. All parts of the dishwasher must be able to move freely.
4. Take care to avoid damaging the cell when removing it from the dishwasher. **GENTLY LIFT THE CELL STRAIGHT UP TO PREVENT DAMAGE TO IONIZER WIRES AND COLLECTOR PLATES.**
5. The cell may be hot when removed from the dishwasher. Allow to cool or wear protective gloves. Make sure that all water is drained off when removing the cell from the dishwasher.

6. If dirt stains or detergent residue remain after washing, it may be necessary to rewash the cell or switch detergent.

## ALTERNATE CELL CLEANING METHOD

If an automatic dishwasher is not available or not of sufficient size to accommodate the cell, a large container capable of holding the electronic cell can be used.

1. Mix an alkaline detergent with hot water in a ratio of 4 oz. of detergent to 1 gal. of water. Water temperature should be between 150°F and 170°F. Be careful to avoid prolonged skin contact with solution and **DO NOT** splash solution in the eyes.
2. Soak the cell in the solution for about 15 minutes. The solution should be agitated in some way every 2 to 3 minutes by sloshing or stirring the solution.
3. Remove the cell from the cleaning solution and place in a clean container of hot water 150°F to 170°F for rinsing and let set for 10 minutes.
4. Remove the cell from the rinse water and allow to drain and dry before using.
5. If there is any detergent residue remaining, rinse again, since it may affect the efficiency of the air cleaner.

**NOTE:** The ionizer wires may become so dirty that an occasional cleaning is recommended. With a damp cotton ball, wipe the ionizer wires by placing the wire between finger and thumb.

## Discoloration of the cell

Occasionally, after the cleaning process, the cell may seem stained. If the stain is black or very dark, it is probably detergent residue and should be rinsed off at once. If yellowing appears, it is probably stain from tobacco or other smoke.

The yellowing does not affect air cleaning efficiency. Use an ammonia based or butyl based detergent to clean tobacco tar and other smoke residue from the collector plates.

# Replacing the cell in cabinet

After the cell has been washed, check for broken ionizer wires and bent collector plates. If broken wires are observed, return unit to Authorized Warranty Station for wire replacement. If bent collector plates are observed, carefully straighten with a screwdriver or other flat object. **BE CERTAIN THAT NO TWO COLLECTOR PLATES ARE TOUCHING AS THIS WILL CAUSE ARCING AND PREVENT THE AIR CLEANER FROM OPERATING PROPERLY.**

Remember that the electronic air cleaner has a cell key which prevents the cell from being positioned incorrectly. If the

cell seems stuck when being inserted or the access cover will not fit securely, check to be sure that the cell is being positioned properly. If excessive force is used, the cell or air cleaner unit could be damaged. Airflow arrows point toward fan motor.

If the cell is placed into the air cleaner while still damp, the indicator light may not come on until the cell is dry, which would normally take about two hours. If the cell is energized and annoying snapping sounds occur, the cell should be removed from the air cleaner and allowed to thoroughly dry.

## Activated carbon filter

The activated carbon filter should be replaced when it is no longer effective in eliminating odors. The life of the carbon filter will depend on the concentration of odors and fumes in the air passing through the air cleaner. Under normal

circumstances, the carbon filter should last up to six months. **THE CARBON FILTER MUST BE IN PLACE FOR THE AIR CLEANER TO OPERATE.**

## Consumer troubleshooting guide

In the event that you experience problems with the operation of your air cleaner, please...

- Make sure electronic cell is clean, dry and properly installed.
- Make sure pre-filter and carbon filter are both properly installed.

- Make sure the top cover is properly snapped in place.
- Check fan motor and indicator lamp on all speed settings starting with low.

If your air cleaner still has any of the following problems, proceed step by step as shown below until no further action should be taken.

<p align="center"><b>PROBLEM 1</b></p> <p><b>FAN OFF LAMP OFF</b></p> <p>Make sure the supply cord is plugged into a standard household receptacle.</p> <p>Make sure there is voltage to the receptacle by testing with another electric device.</p> <p>Make sure the carbon filter is in place.</p> <p>Make sure the top access cover is properly in place in order to actuate the interlock switch. The interlock switch is provided for consumer safety and should never be bypassed.</p> <p>No further corrective actions should be taken by the consumer. Return the unit to an Authorized Warranty Station for repair. See Page 12.</p>
---

<p align="center"><b>PROBLEM 2</b></p> <p><b>FAN ON LAMP OFF</b></p> <p>Check the electronic cell to see if any of the collector plates are touching. Gently straighten and evenly space the plates.</p> <p>Check the electronic cell to see if any of the ionizer wires are broken. See Major Components for their location. If broken wires are observed, no further corrective actions should be taken by the consumer. Return the unit to an Authorized Warranty Station for repair. See Page 12.</p>
---

<p align="center"><b>PROBLEM 3</b></p> <p><b>FAN OFF LAMP ON</b></p> <p>This condition represents a non-serviceable failure of the air cleaner. Return the unit to an Authorized Warranty Station for repair. See Page 12.</p>
--

# Troubleshooting electronic air cleaner

## Electrical Troubleshooting Procedure for Electronic Air Cleaner

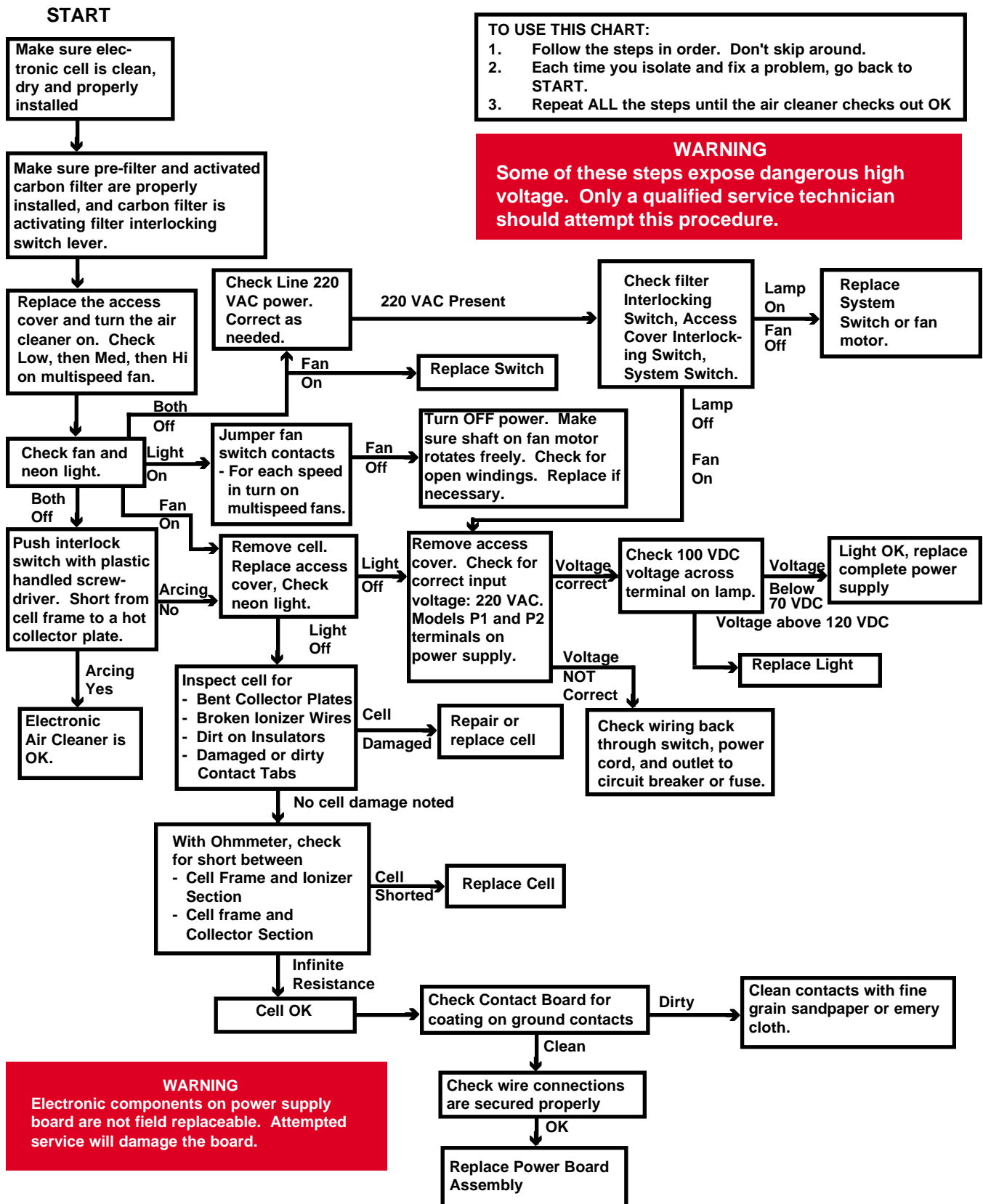



# Wiring Schematic

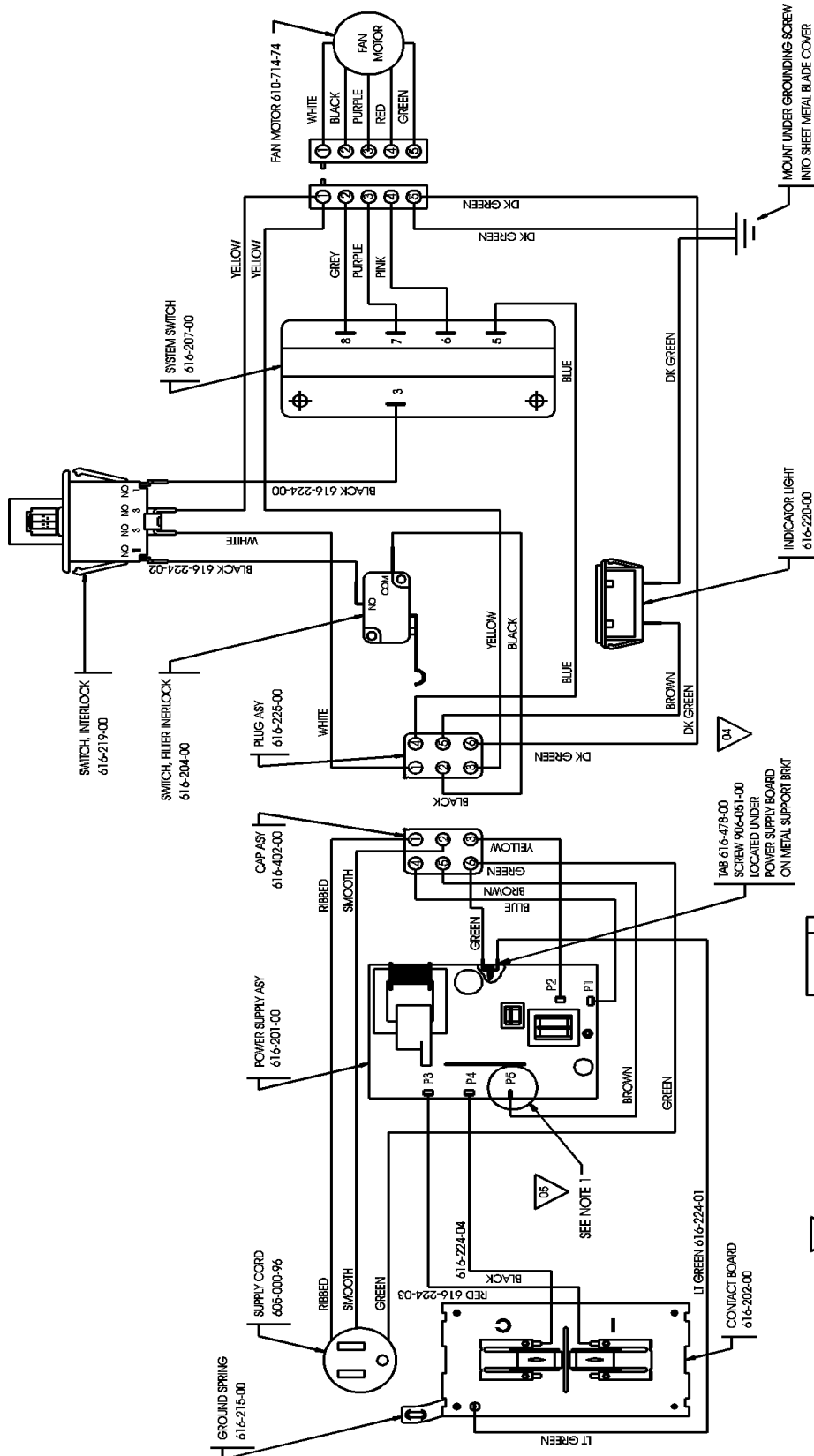

Part No. 616-216-00

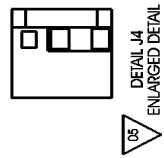

NOTE:  
1. MANUFACTURING TO POSITION JUMPER P5  
AS SHOWN IN DETAIL J4

# Major Components

**C-90A**

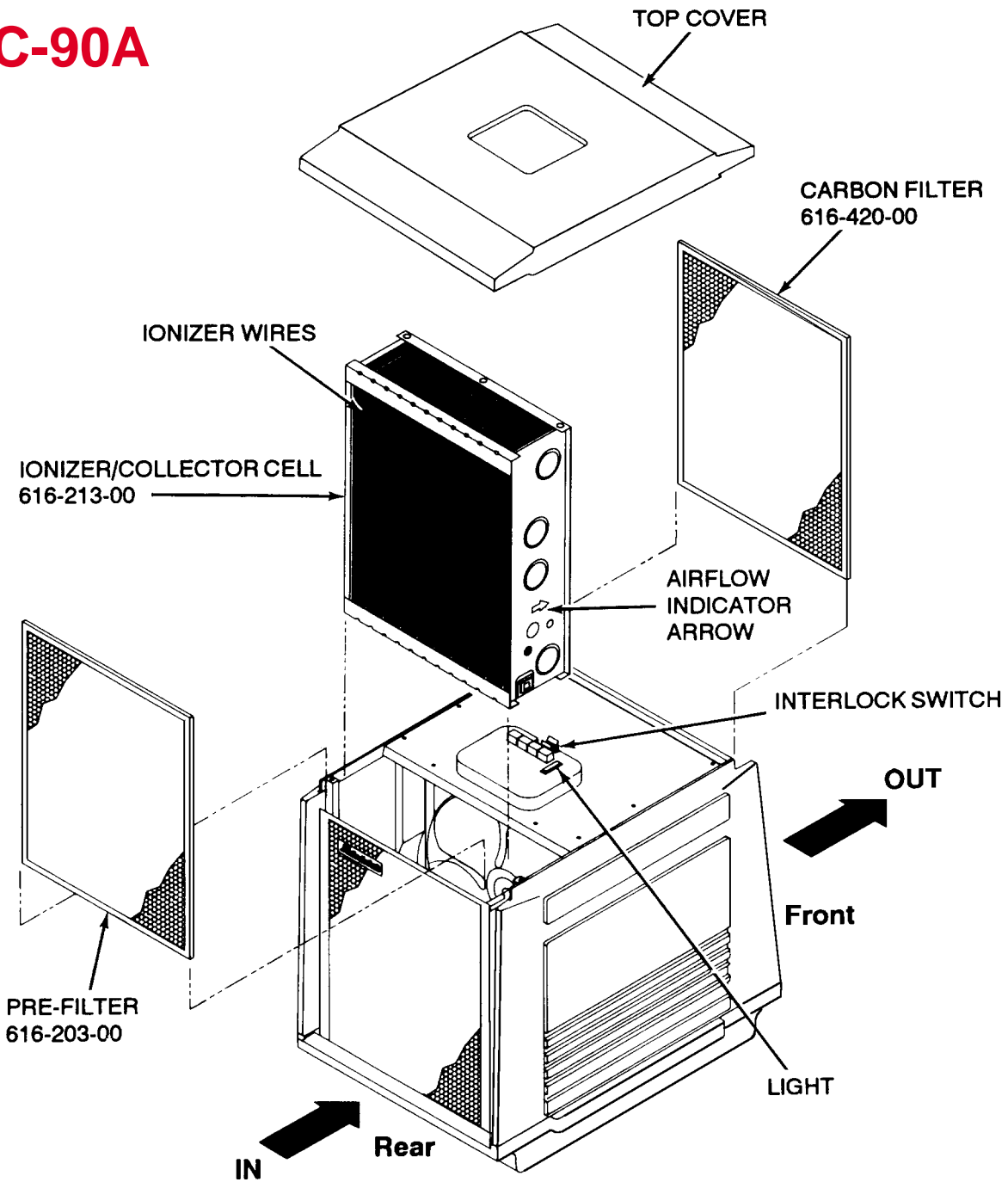

## C-90A ELECTRONIC AIR CLEANER COMPONENT PARTS LISTING

PART NO.	DESCRIPTION	QTY.
616-203-00	FILTER, PRE .....	1
616-420-00	FILTER, CARBON .....	1
616-424-01	CARTON, RSC .....	1
616-425-00	PACKING, TOP & BOTTOM .....	2
920-010-01	OWNERS MANUAL C-90A .....	1
616-209-00	BUTTON, SYSTEM SWITCH .....	4
616-211-01	SIDE, CABINET .....	2
616-212-01	LID, CABINET .....	1
906-081-00	SCREW, #4 - 24 X 3/4" .....	2
616-417-00	FASTENER .....	4
616-210-01	BASE, CABINET .....	1
906-080-00	SCREW .....	10
917-018-00	STRAIN, RELIEF .....	1
616-206-00	FAN, 5 BLADE .....	1
616-217-00	ORIFICE .....	1
616-410-00	BLADE COVER ASSEMBLY .....	1
616-411-01	PANEL, CONTROL .....	1
906-022-08	SCREW, SELF-TAPPING .....	2
906-047-02	SCREW, TAPPING 8A X 3/8 H/W SER ZP .....	2
906-051-00	SCREW, T/C 8-32 X 3/8 H/W SER ZP .....	5
605-000-96	SUPPLY CORD .....	1
610-714-74	MOTOR .....	1
616-201-00	POWER SUPPLY .....	1
616-202-01	CONTACT BOARD .....	1
616-207-00	SWITCH, SYSTEM .....	1
616-215-00	SPRING, CELL GROUND .....	1
616-219-00	SWITCH, INTERLOCK .....	1
616-220-00	LIGHT INDICATOR .....	1
616-224-00	WIRE .....	1
616-224-01	WIRE .....	1
616-224-02	WIRE .....	1
616-224-03	WIRE .....	1
616-224-04	WIRE .....	1
616-225-00	PLUG ASSEMBLY .....	1
616-402-00	CAP ASSEMBLY .....	1
616-478-00	TAB, DUAL GROUNDING .....	1
616-977-00	TWIST LOK STANDOFF .....	3
616-218-00	BRACKET, GRILLE .....	4
616-404-00	GRILLE .....	2
616-976-00	RIVET, PLASTIC .....	6
616-665-00	SPACER, POWER SUPPLY .....	2
616-213-00	IONIZER/COLLECTOR CELL .....	1
616-556-00	IONIZER WIRE .....	9
616-204-00	SWITCH, FILTER INTERLOCK .....	1
616-407-00	BRACKET, MOTOR MOUNT .....	1

## Regional C-90A Authorized Warranty Repair Stations



**1 R & B Appliance Parts**  
5070 Lindsay Ct.  
Chino, California 91710  
TEL: 714/591-9405  
1-800-421-2189

**3 B & G Service Co.**  
3950 North Elston  
Chicago, Illinois 60618  
TEL: 773/588-2290

**4 Reeve Air Conditioning, Inc.**  
2501 South Park Road  
Hallandale, Florida 33009  
TEL: 954/962-0252  
1-800-962-3383

**2 Alamo Service Co.**  
1450 North Flores  
San Antonio, Texas 78212  
TEL: 210/227-7571  
1-800-328-2450

**5 Superior A/C Service, Inc.**  
524 Sackett Street  
Brooklyn, New York 11217  
TEL: 718/852-8200

# Use Factory Certified Parts . . .

## Friedrich

**FRIEDRICH AIR CONDITIONING CO.**

- Post Office Box 1540 • San Antonio, Texas 78295-1540
- 4200 N. Pan Am Expressway • San Antonio, Texas 78218-5212
- (210) 357-4400 • FAX (210) 357-4480

Visit us on the Internet at [www.friedrich.com](http://www.friedrich.com)

Printed in the U.S.A.