

This Owner's Manual is provided and hosted by [Appliance Factory Parts](http://ApplianceFactoryParts.com).

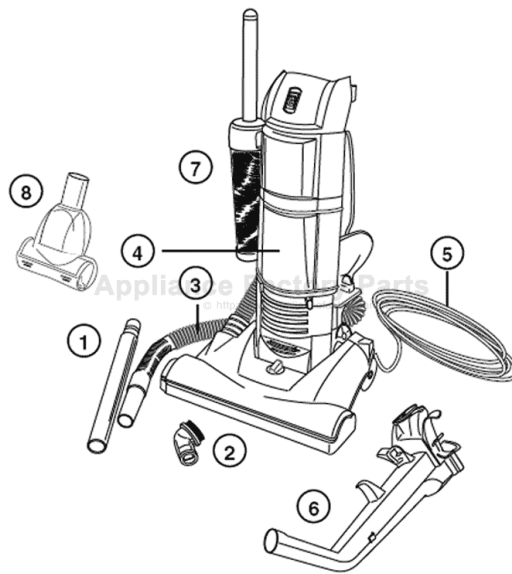

Eureka 2972 Owner's Manual

[Shop genuine replacement parts for Eureka 2972](#)



[Find Your Eureka Vacuum Cleaner Parts - Select From 853 Models](#)

----- Manual continues below -----

EUREKA

We live and breathe clean.™

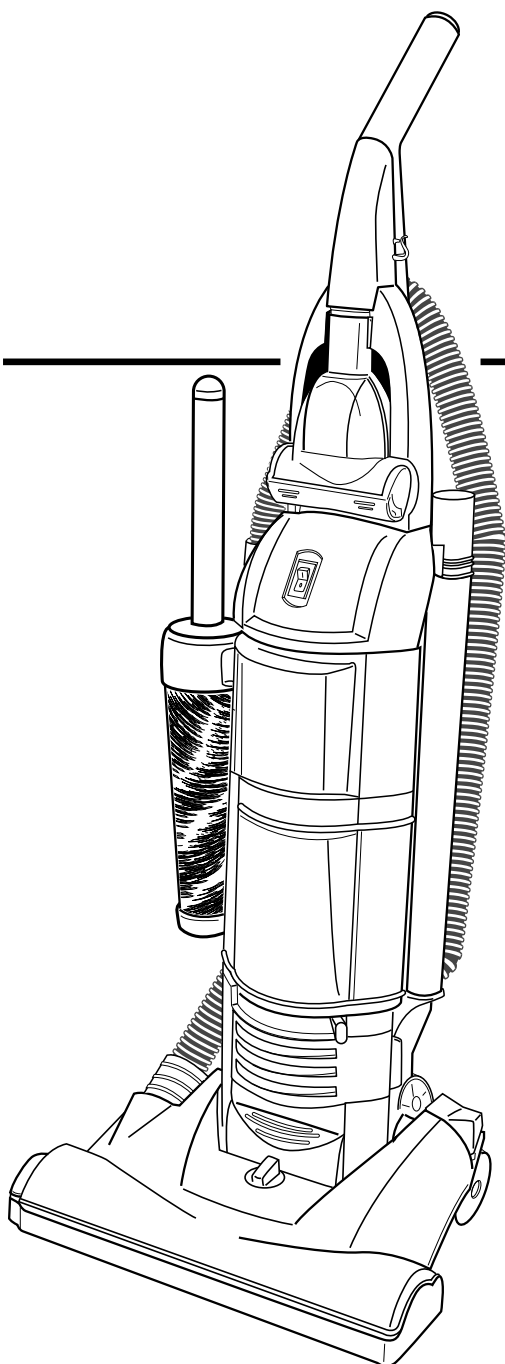

Upright Vacuum Cleaner

Household Type

OWNER'S GUIDE 2940-2969 Series 2970-2999 Series

IMPORTANT

Do not return to the store. For assembly problems or questions, for replacement of broken or missing items, or to order replacement parts and accessories to be shipped direct to you contact:

Eureka Customer Service toll free at 1-800-282-2886, 8 a.m. to 7:30 p.m. (CST), Monday - Friday and 10 a.m. to 6:30 p.m. Saturday. Or visit our web site, **www.eureka.com**

***En Mexico llame al (55) 5343-4384**

INDEX

Important Information	2
Assembly Parts.....	3
How to Assemble.....	3
How to Use	4
Accessories	4
Filters.....	5
Dust Cup.....	5
Brush Roll.....	6
Brush Roll Belt.....	6-7
Headlight	7
How to Clear Blockages	8
Troubleshooting	9
Warranty	10

PLEASE RETAIN

We suggest you record the model, type and serial numbers below. They are located on the silver rating plate on your cleaner. For prompt and complete service information, always refer to these numbers when inquiring about service.

Model & Type _____

Serial No. _____

It is also important to keep your receipt as proof of date of purchase.

IMPORTANT SAFEGUARDS

When using an electrical appliance, basic precautions should always be followed, including the following:

READ ALL INSTRUCTIONS BEFORE USING THIS VACUUM CLEANER.

WARNING

To reduce the risk of fire, electric shock, or injury:

- Do not use outdoors or on wet surfaces.
- **Do not leave vacuum cleaner when plugged in.** Turn off the switch and unplug the electrical cord when not in use and before servicing.
- Do not allow to be used as a toy. Close attention is necessary when used by or near children.
- Use only as described in this manual. Use only manufacturer's recommended attachments.
- Do not use with damaged cord or plug. If vacuum cleaner is not working as it should, has been dropped, damaged, left outdoors, or dropped into water, return it to a service center before using.
- Do not pull or carry by cord, use cord as a handle, close door on cord, or pull cord around sharp edges or corners. Do not run vacuum cleaner over cord. Keep cord away from heated surfaces.
- Do not use extension cords or outlets with inadequate current carrying capacity.
- Turn off all controls before unplugging.
- Do not unplug by pulling on cord. To unplug, grasp the plug, not the cord.
- Do not handle plug or vacuum cleaner with wet hands.
- Do not put any object into openings. Do not use with any opening blocked; keep free of dust, lint, hair, and anything that may reduce airflow.
- This vacuum cleaner creates suction and contains a revolving brush roll. Keep hair, loose clothing, fingers, and all parts of body away from openings and moving parts.
- Do not place cleaner on furniture or stairs as the brush roll may cause damage. Place cleaner on floor with the handle in storage position while using attachments.
- Do not pick up anything that is burning or smoking, such as cigarettes, matches, or hot ashes.
- Do not use without dust cup in place.
- Do not use without filter in place.
- Belt pulleys can become hot during normal use. To prevent burns, avoid touching the belt pulley when servicing the drive belt.
- Use extra care when cleaning on stairs.
- Do not use to pick up flammable or combustible liquids such as gasoline, or use in areas where they may be present.
- Store your cleaner indoors in a cool, dry area.
- Keep your work area well lighted.
- Unplug electrical appliances before vacuuming them.

SAVE THESE INSTRUCTIONS

To reduce the risk of electric shock, this appliance has a polarized plug (one blade is wider than the other). This plug will fit in a polarized outlet only one way. If the plug does not fit fully into the outlet, reverse the plug. If it still does not fit, contact a qualified electrician to install the proper outlet. Do not change the plug in any way.

GENERAL INFORMATION

Use the cleaner to pick up dirt and dust particles. Avoid picking up hard or sharp objects that could damage the vacuum cleaner.

Service Information

The instructions in this booklet serve as a guide to routine maintenance. For additional service information, telephone our toll free number for the nearest Eureka Authorized Warranty Station. **You should know the model, type and serial number or date code when you call:**

USA: 1-800-282-2886

Mexico: (55) 5343-4384

Canada: 1-800-282-2886

If you prefer, you can write to Electrolux Home Care Products North America, Consumer Service, P O Box 3900, Peoria, Illinois, 61612, USA. In Canada, write to Electrolux Home Care Products Canada, 866 Langs Drive, Cambridge, Ontario N3H 2N7. Refer to The Eureka Warranty for complete service information.



DO NOT OIL the motor or the brush roll. The motor and brush roll are permanently sealed and lubricated.

Thermal Cut Off

This vacuum cleaner has a special thermostat that protects the cleaner in case of motor overheating. If the cleaner suddenly shuts off, push the on/off switch off (0) and unplug the cleaner. Check the cleaner for a possible source of overheating such as a full dust cup, a blocked hose or clogged filter. If these conditions are found, fix them and wait at least 30 minutes before attempting to use the cleaner. After the 30 minute period, plug the cleaner back in and push the on/off switch on (I). If the cleaner still does not run, then take it to a Eureka Authorized Service Center for repair.

Assembly Parts

- ① Wand and Crevice Wand. (Pull apart.)
- ② Dusting Brush.
- ③ Hose.
- ④ Vacuum Cleaner Body.
- ⑤ Electrical Cord.
- ⑥ Handle.
- ⑦ Self Cleaning Duster.
- ⑧ Turbo Tool.
- ⑨ Screws located in the accessory package.

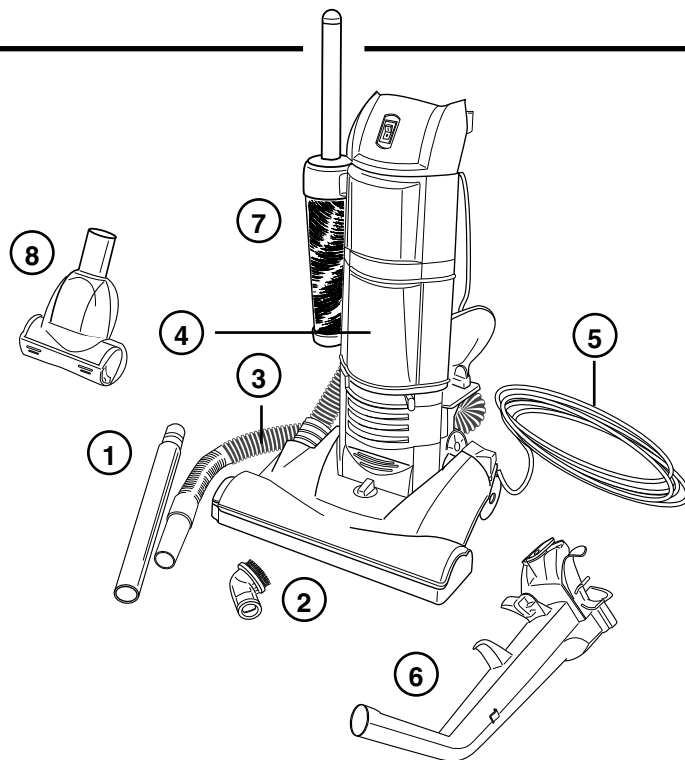

How To Assemble

CAUTION: Assemble the cleaner before using.

CAUTION: Moving parts. Make sure ON/OFF switch is in the OFF position before plugging in.

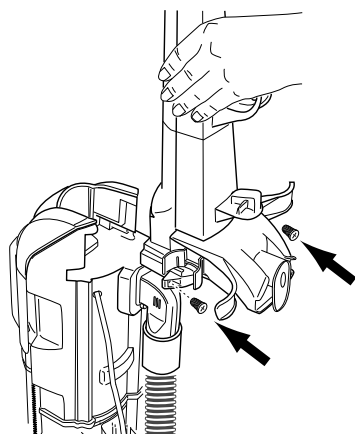

- ① Slide the handle into the grooves at the top of the vacuum body as shown.
- ② Place the two screws (supplied) into the holes at back of the unit and tighten with a screwdriver.

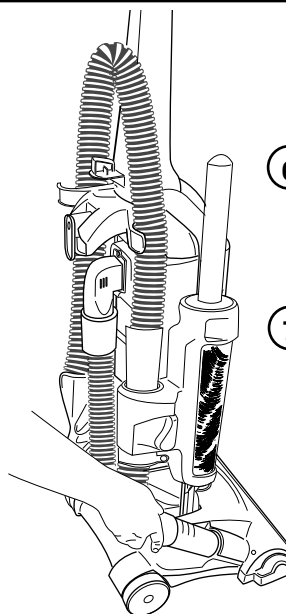

- ⑥ Place the hose on the back of the vacuum, wrapping it up and over the hose hook as shown.
- ⑦ Secure the bottom of the self cleaning duster to the hose retainer. Firmly push the end of the hose into the top of the self cleaning duster.

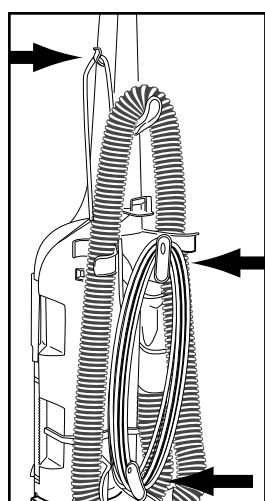

- ③ Pull the electrical cord up to the cord retainer and firmly push down into retainer. This will keep the cord out of the way the next time you vacuum.
- ④ Wind the cord around the two cord hooks on the back of the vacuum.
- ⑤ Secure plug to the cord to prevent unwinding.

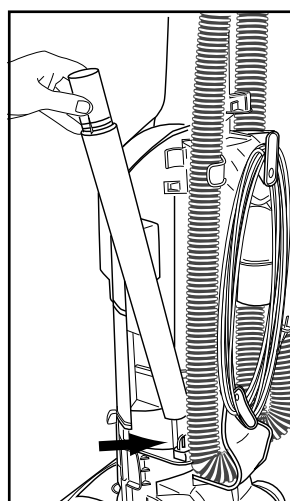

- ⑧ Store the wands on the side of the vacuum in front of the hose.
- ⑨ Store the dusting brush on its holder.

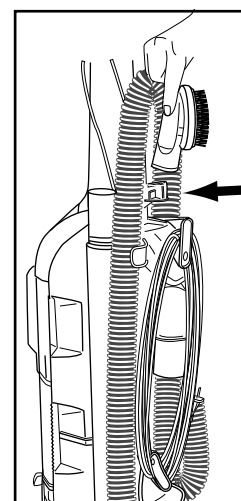

HOW TO USE



WARNING: Avoid injury. Keep loose clothing, hair, fingers, and all other parts of body away from any moving part (such as the revolving brush). Turn off the switch and unplug the cleaner before changing the cleaner height setting.

ON/OFF Switch.

International symbol **I** means On, International symbol **O** means Off.

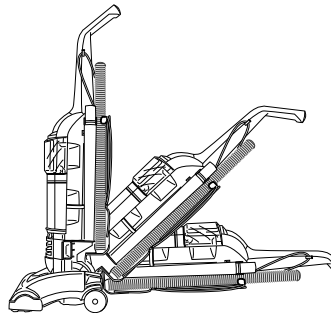
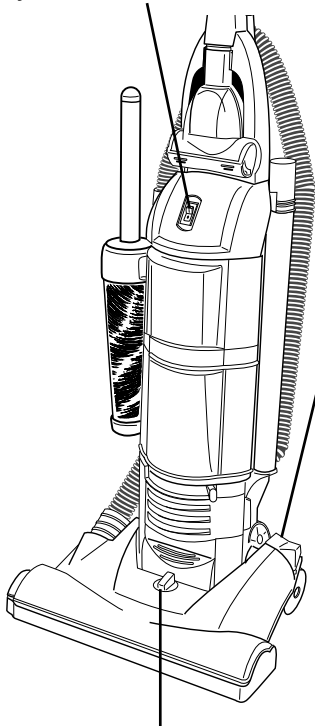

Handle Release. Step on handle release to pull handle back to a comfortable operating position. To lower handle completely to the floor, depress handle release a second time.

Helpful Information:

Before cleaning under low furniture, check area first for objects that might harm the unit or block the vacuum hose.

Cleaner Height Setting. An adjustment that raises or lowers the cleaner base to match the type of floor surface. With the cleaner cord unplugged, set the adjustment to lowest setting for maximum carpet cleaning. **If the cleaner is difficult to push, move adjustment to next highest setting until cleaner is comfortable to push.** The brush roll must reach the carpet for effective cleaning. For ease in moving the adjustment knob, place handle in operating position and tilt cleaner back to remove weight from front wheels.

Helpful Information:

Listen to your cleaner. If you notice a change in the sound of the motor or a change in performance, it could simply indicate a common usage or maintenance issue. Such as, a need to raise or lower the carpet height adjustment, possible blockage in hose or brush roll area, or a broken or loose brush roll belt. These are all easy to fix and the instructions are included in this owner's guide. Becoming familiar with the information in this guide will help you to get the best possible performance from your new cleaner for many years to come.



NOTE: While using accessories, do not place cleaner on furniture or steps as the brush roll may cause damage. Place cleaner on floor with the handle in storage position.

1. To use accessories remove hose from hose retainer in hood of cleaner by lifting up and twisting.
2. Place desired accessory onto end of hose or wand.

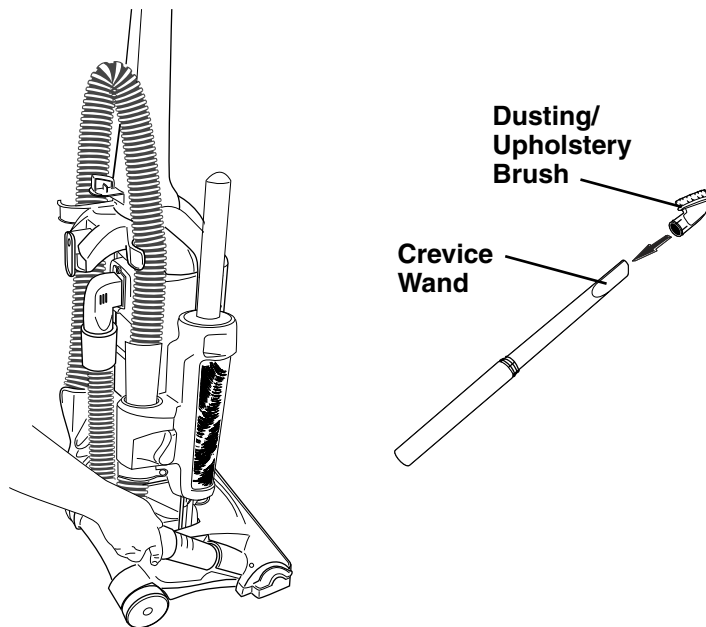

Dusting/Upholstery Brush is for furniture, blinds, books, lamp shades, shelves, curtains, draperies, cushions and fabrics.

Crevice Wand cleans corners, stairs, baseboards, and between cushions.

Nested extension wands to add reach.

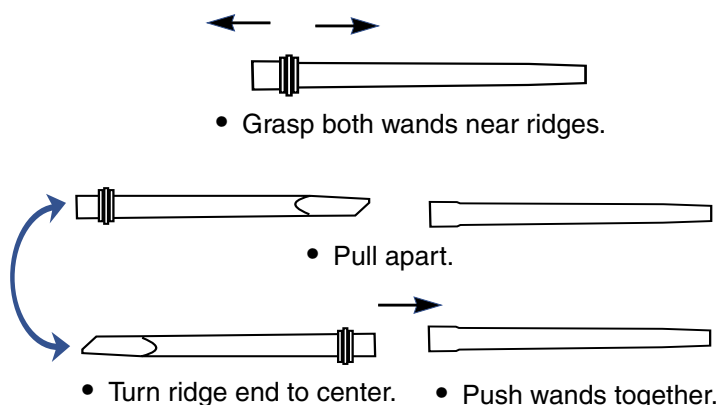

The instructions in the booklet serve as a guide to routine maintenance. To avoid unnecessary service calls, check the top and bottom filters, belt and brush roll often.

ROUTINE MAINTENANCE

NOTE: Turn off the switch and unplug the electrical cord before routine maintenance. Never operate the vacuum cleaner without the top and bottom filters in place.

NOTE: When vacuuming carpet fresheners or cleaners, powder, plaster dust, or similar fine substances, the top and bottom filters will require more frequent maintenance.

Removing the Dust Cup:

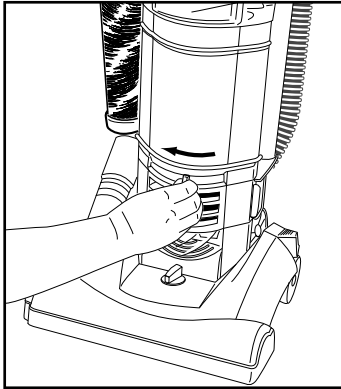

Remove dust cup by sliding dust cup lever from right to left.

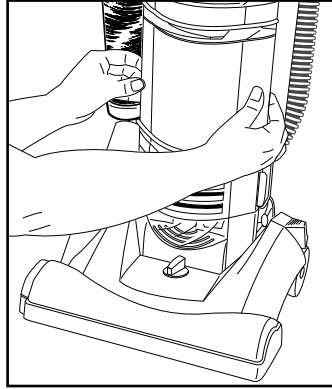

Grasp dust cup with both hands and pull out.

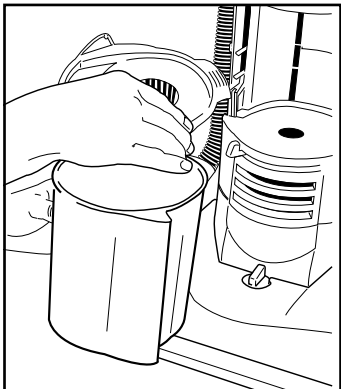

Remove lid, and shake free of debris.

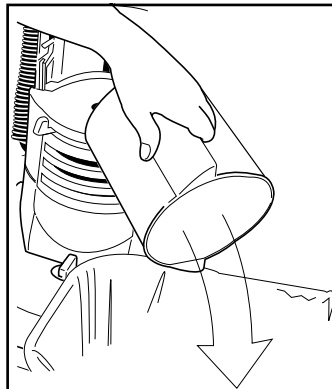

Empty dust cup into trash.

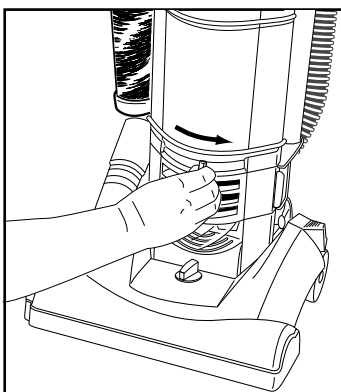

Replace dust cup lid, reposition in cleaner body and secure by moving lever from left to right.

Top Filter Maintenance:

This new Eureka Upright uses a cyclone system as a primary filter and a secondary or top mounted filter that has been moved outside of the dirt cup. This makes emptying the dirt cup much easier and less messy. It is normal for this filter to trap fine particles, pet hair, and carpet fuzz. It should be cleaned periodically depending on vacuuming conditions. For optimum performance replace it every 12 months.

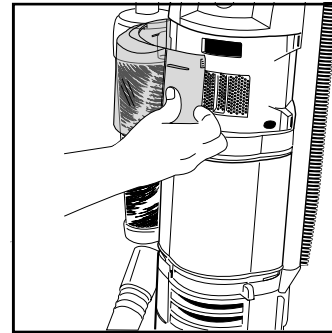

Remove top filter cover by grasping right edge and pivoting to the left.

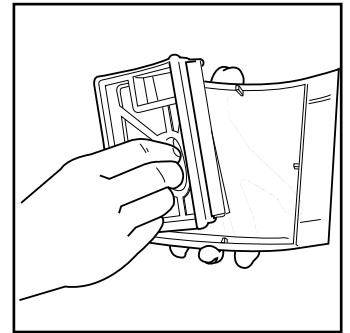

Remove filter frame from top filter cover.

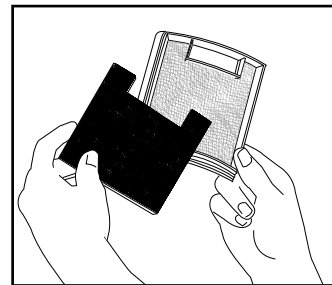

Remove foam from filter frame. Shake filter frame and foam filter to remove excess dust.

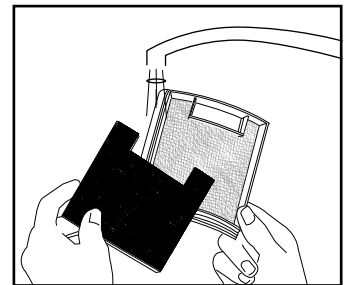

If necessary, the filter frame and foam filter can be rinsed in luke warm water and air dried. **NOTE: The filter frame, foam and cover are not dishwasher safe.**

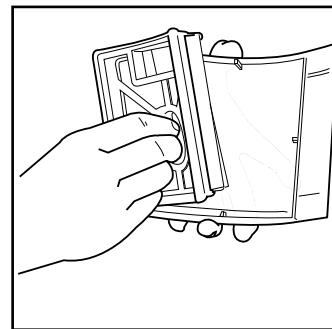

When dry, replace foam filter into filter frame.

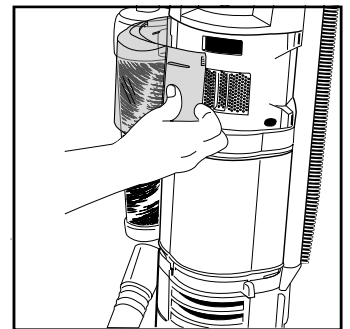

Replace filter frame into top filter cover. Replace top filter cover by pivoting back onto cleaner from left to right.



WARNING: Always check foam filter and frame are correctly installed in the cover before using vacuum.

ROUTINE MAINTENANCE

(Continued)

Bottom Filter Maintenance:

Check the bottom filter frequently. For optimum performance, replace bottom filter every 12 months.

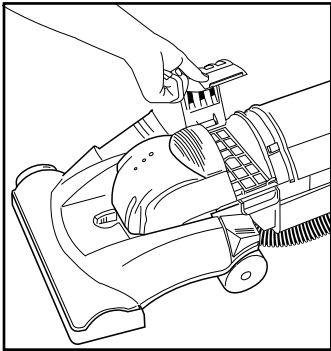

Remove the bottom filter cover by grasping the right edge and pivoting to the left.

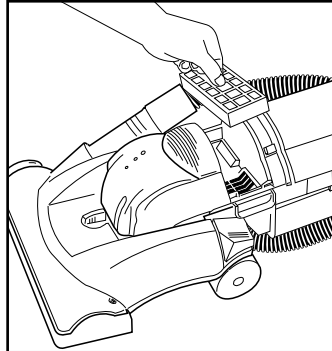

Pull filter frame from unit by pulling on tab in center.

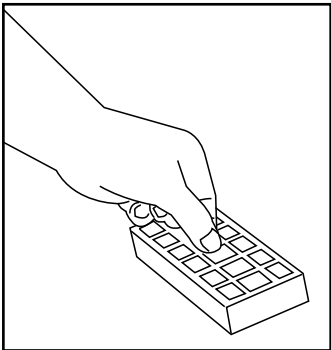

On some models, remove filter pad and shake to remove excess dust. If necessary this pad can be cleaned by vacuuming with another cleaner.

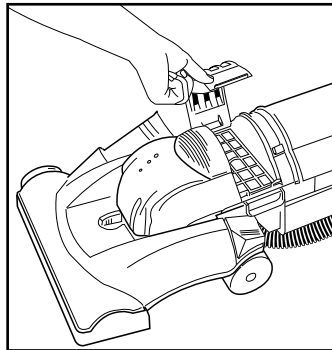

Replace filter into unit. Replace bottom filter cover by pivoting back onto cleaner from left to right.

PERIODIC MAINTENANCE



CAUTION: Turn off the switch and unplug the electrical cord before periodic maintenance. Never operate the vacuum cleaner without the dust bag or filter assembly in place.

Brush Roll

The brush roll turns as it sweeps and combs the carpet nap. Remove hair and threads from the brush roll so it continues brushing the carpet. To maintain the most efficient cleaning, the bristles must touch the carpet. To test the bristle length, hold a ruler against the underneath side of the cleaner. If the bristles no longer touch the ruler, replace the brush roll.

Brush Roll Belt, Style U

The brush roll belt turns the brush roll to agitate, sweep, and comb the carpet nap. Check the belt regularly to be sure it is in good condition. Replace the belt if it stretches, cracks or loses tension. Cut away any hair or threads wound around the brush roll or the belt pulley because the buildup could cause the belt to rotate unevenly.

How To Replace Brush Roll Belt

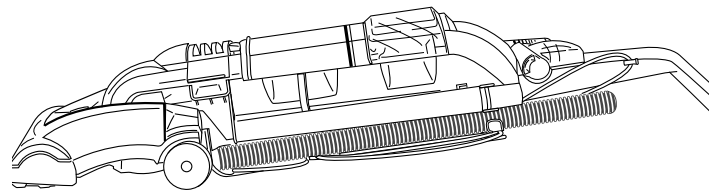

1. Lower handle to floor to change belt.

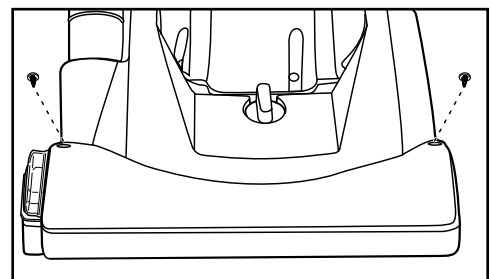

2. Remove the two screws from the top of the hood.

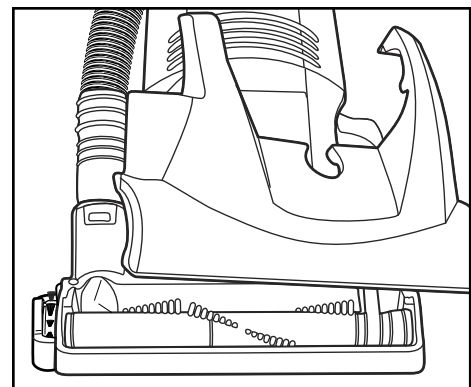

PERIODIC MAINTENANCE (continued)

3. Lift hood to remove.

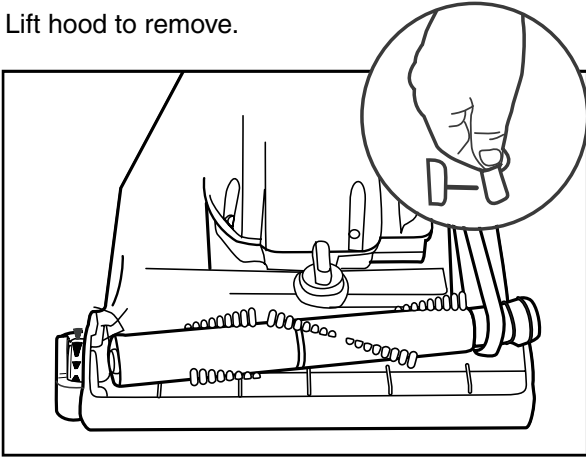

4. Lift right end of brush roll.
5. Remove and discard belt.
6. Place new belt around motor shaft.
7. Place new belt around brush roll pulley.

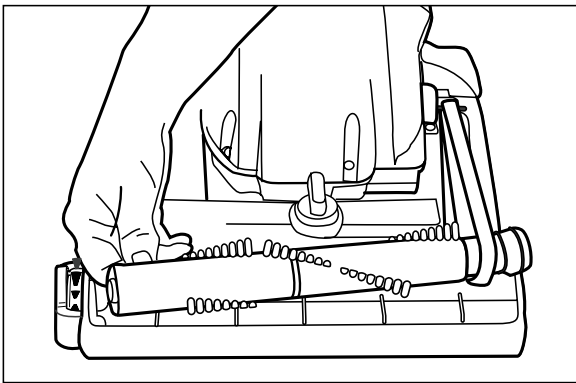

8. Align left end cap with base. Push end cap securely into place. Make sure the square on the brushroll cap is in place.
9. Pull right side of brush roll to stretch belt. Secure right end cap into base.

IMPORTANT

10. Rotate brush roll by hand 2 full rotations to properly position belt.
11. Place hood back on cleaner. Replace and tighten two screws.
12. Return vacuum to upright position.



CAUTION: Turn off the switch and unplug the electrical cord before periodic maintenance.

How to Change Light Bulb

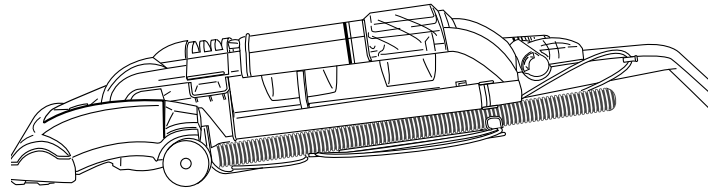

1. Lower handle to floor to change lightbulb.
2. Remove bottom filter cover and filter. (see page 6)

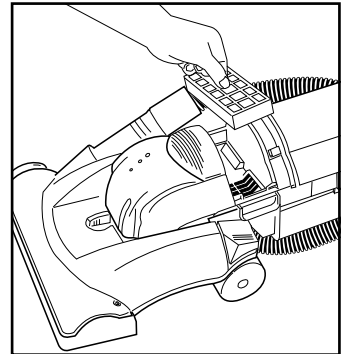
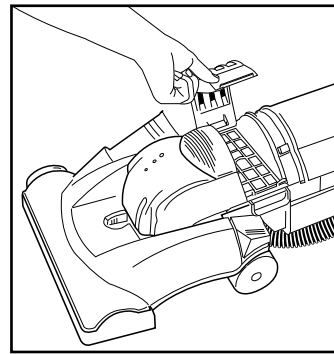

3. Remove screw from lens cover.

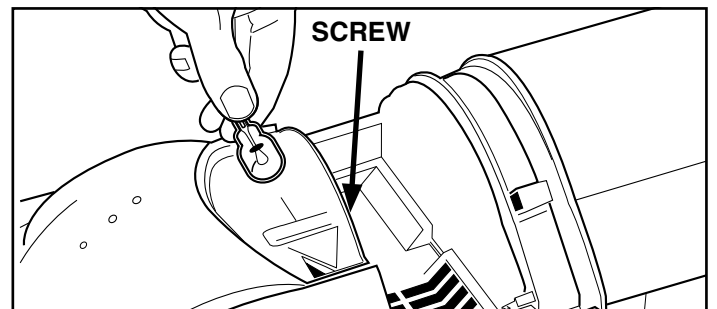

4. Pull old light bulb out of socket.
5. Push new lightbulb into socket.
6. Replace lens cover.
7. Secure with screw.
8. Return vacuum to upright position.



NOTE: Use GENUINE EUREKA replacement light bulb. Part No. 57940-2.



To Clear Blockages in Hose

CAUTION: Turn off the switch and unplug the electrical cord before clearing hose.

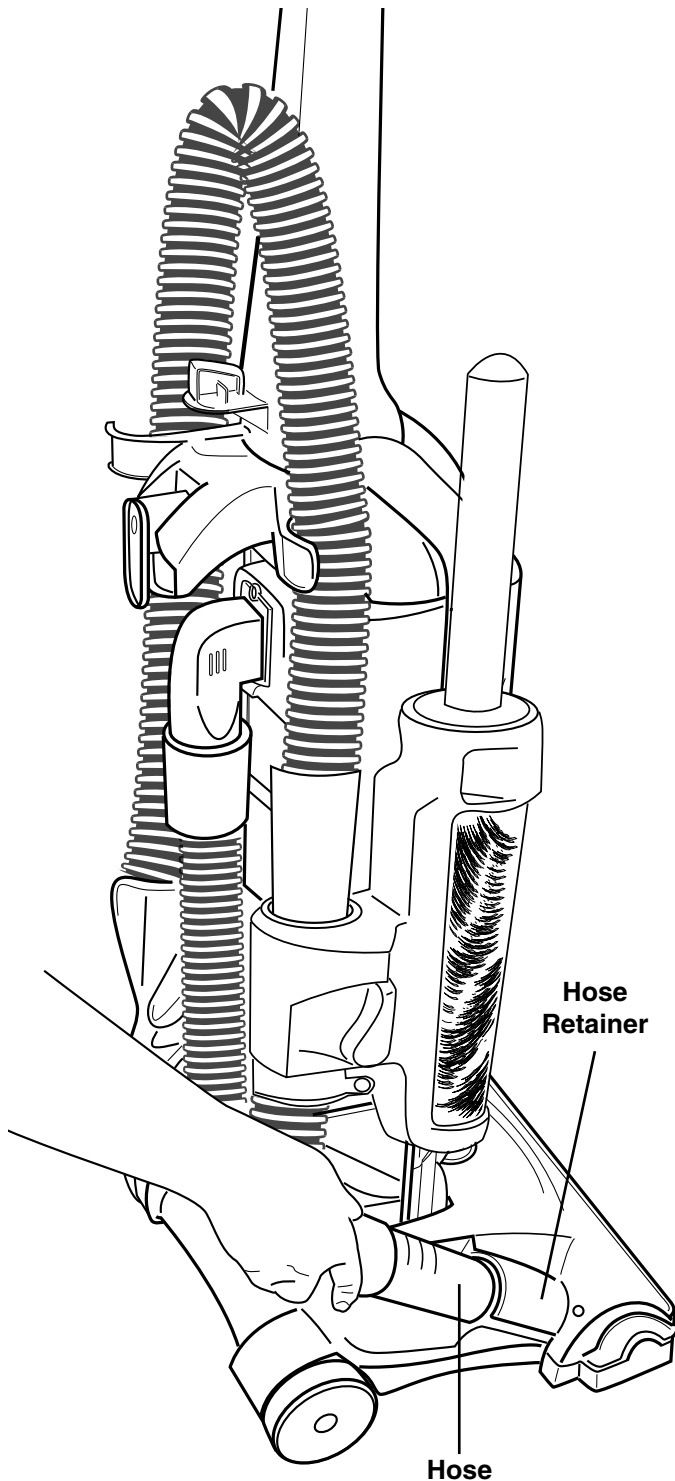

1. Firmly pull the end of the hose from the hose retainer on the hood of the vacuum.
2. Check for blockages in the hose and hose retainer. Flexing the hose may help loosen any blockage. **If no blockage is found, continue to step 4.**

If blockage is found, clear the blockage and replace the hose in the hose retainer. **If the blockage is in the hose retainer and cannot be cleared, continue to step 3.**

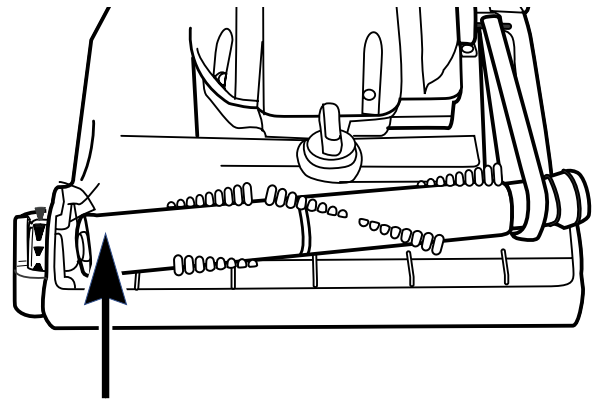

3. Remove the hood from the cleaner and check for a blockage in the brush roll area. Make sure the hose inlet is clear. **If no blockage is found, continue to step 4.**

After the blockage is found and cleared, replace the hood on the cleaner.

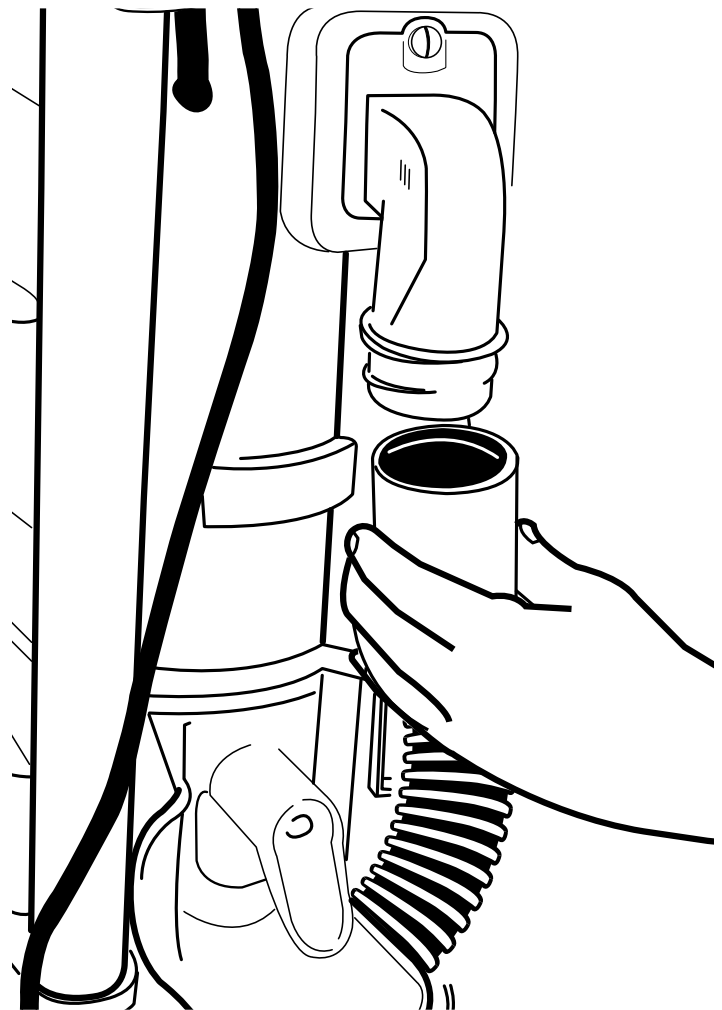

4. Twist the hose from the coupling elbow on the back of cleaner. Check for blockages at cleaner opening and in hose. If a blockage is found, clear the blockage.

The screw attaching the clear hose adapter can be removed for better access to a blockage.

5. Screw the hose back onto the back of the cleaner and replace the other end of the hose into the hose retainer on the hood of vacuum.

Problem Solving

NOTE: Turn off the switch and unplug electrical cord before servicing.

PROBLEM	CAUSE	SOLUTION
Motor will not start	<input type="radio"/> Electric Plug	<input type="checkbox"/> Push plug securely into outlet. Try another outlet Check circuit breaker
Motor stops suddenly	<input type="radio"/> Thermal Cut Off	<input type="checkbox"/> Page 2
Does not clean the carpet or floor	<input type="radio"/> Filters	<input type="checkbox"/> Clean or replace filters. Hint: If picking up fine dust, the filters may not look dirty but a fine substance tends to reduce suction when it blocks the airflow through the filter(s). Page 5 & 6.
	<input type="radio"/> Dust Cup	<input type="checkbox"/> Empty dust cup. Check to insure cup is properly seated and secured with lever engaged. Hint: Be sure both top and bottom filters are in place.
	<input type="radio"/> Hose	<input type="checkbox"/> Be sure hose adapter is secure on back of cleaner. Page 8.
	<input type="radio"/>	<input type="checkbox"/> Remove any blockages from the hose that restricts the airflow. Page 8.
	<input type="radio"/>	<input type="checkbox"/> Check to see that the end of the hose is firmly pressed into the hose retainer in the hood of the vacuum. Page 8.
	<input type="radio"/>	<input type="checkbox"/> Check base hose and long hose. Page 8.
	<input type="radio"/> Belt	<input type="checkbox"/> Replace a broken, cut, loose or out of shape belt. Page 6.
	<input type="radio"/> Brush Roll	<input type="checkbox"/> Clean hair and thread from bristles and end cap area. Replace brush roll if bristles are worn. Page 6.
No suction at the end of hose	<input type="radio"/> Hose Adapter	<input type="checkbox"/> Be sure hose adapter is secure. Page. 8
	<input type="radio"/> Filters	<input type="checkbox"/> Clean or replace filters. Hint: If picking up fine dust, the filters may not look dirty but a fine substance tends to reduce suction when it blocks the airflow through the filter(s). Page 5.
	<input type="radio"/> Hose	<input type="checkbox"/> Remove any clogs from hose that restricts the airflow. Check base hose and long hose. Page. 8
	<input type="radio"/> Dust Cup	<input type="checkbox"/> Empty dust cup. Check to insure cup is properly seated and secured with lever engaged. Hint: Be sure both top and bottom filters are in place. Page 5.
Headlight not working	<input type="radio"/> Light Bulb	<input type="checkbox"/> Replace light bulb. Page 7.
Noise from the brush roll area	<input type="radio"/> Brush Roll	<input type="checkbox"/> Remove hood and clean debris or items from the brush roll area. Page 6.
	<input type="radio"/> Belt	<input type="checkbox"/> Replace a broken, cut, loose or out of shape belt. Page 6.
Cleaner is hard to push	<input type="radio"/> Cleaner Height Setting	<input type="checkbox"/> Put handle in operating position. Tilt the cleaner back to raise the front wheels off the floor. Then turn the knob to a higher setting.
	<input type="radio"/> Belt	<input type="checkbox"/> Replace a broken, cut, loose or out of shape belt. Page 6.
Cleaner height knob will not turn	<input type="radio"/> Cleaner Height Setting	<input type="checkbox"/> Hint: Put handle in operating position. Tilt the cleaner back to raise the front wheels off floor. Then turn the knob. Page 4.
Missing parts	<input type="radio"/>	<input type="checkbox"/> Call 1-800-282-2886 between 8 a.m. to 7:30 p.m., (CST), Monday - Friday and 10 a.m. to 6:30 p.m. (CST) Saturday. Know the model and serial numbers when you call.
Questions	<input type="radio"/>	<input type="checkbox"/> Call 1-800-282-2886 between 8 a.m. to 7:30 p.m., (CST), Monday - Friday and 10 a.m. to 6:30 p.m. (CST) Saturday. Know the model and serial numbers when you call.

THE EUREKA LIMITED WARRANTY

What This Warranty Covers

Your Eureka cleaner is warranted to be free from all defects in material and workmanship in normal household use for a period of one year. The warranty is granted only to the original purchaser and members of his or her immediate household. The warranty is subject to the following provisions.

What This Warranty Does Not Cover

- Parts of the cleaner that require replacement under normal use, such as disposable dust bags, filters, drive belts, light bulbs, and brush roll bristles, impellers and cleaning.
- Damages or malfunctions caused by negligence, abuse, or use not in accordance with the Owner's Guide.
- Defects or damages caused by unauthorized service or the use of other than Genuine Eureka parts.

What the Manufacturer Will Do

The manufacturer will, at its option, repair or replace a defective cleaner or cleaner part that is covered by this warranty. As a matter of warranty policy, the manufacturer will not refund the consumer's purchase price.

Warranty Registration

Please fill out and return the warranty registration card accompanying your cleaner.

Obtaining Warranty Service

To obtain warranty service you must return the defective cleaner or cleaner part along with proof of purchase to any Eureka Authorized Warranty Station.

You will find the nearest location in the Yellow Pages, under "Vacuum Cleaners – Service and Repair." Be certain that the Warranty Station is "Eureka Authorized."

For the location of the nearest Eureka Authorized Warranty Station or for service information, telephone toll free:

USA: 1-800-282-2886

Mexico: (55) 5343-4384

Canada: 1-800-282-2886

If you prefer you can write to Electrolux Home Care Products North America, P O Box 3900, Peoria, Illinois 61612, USA. In Canada write to Electrolux Home Care Products Canada, 866 Langs Drive, Cambridge, Ontario N3H 2N7.

If it is necessary to ship the cleaner outside your community to obtain warranty repair, you must pay the shipping charges to the Eureka Authorized Warranty Station.

Return shipping charges will be paid by the Warranty Station. When returning parts for repair, please include the model, type, and serial number from the data plate on the cleaner.

Further Limitations and Exclusions

Any warranty that may be implied in connection with your purchase or use of the cleaner, including any warranty of Merchantability or any warranty for Fitness For A Particular Purpose is limited to the duration of this warranty. Some states do not allow limitations on how long an implied warranty lasts, so the above limitations may not apply to you.

Your relief for the breach of this warranty is limited to the relief expressly provided above. In no event shall the manufacturer be liable for any consequential or incidental damages you may incur in connection with your purchase or use of the cleaner. Some states do not allow the exclusion or limitation of incidental or consequential damages, so the above limitation or exclusion may not apply to you.

This warranty gives you specific legal rights. You may also have other rights which vary by state.



Questions & Answers about Genuine Eureka Products

Q: Why should I use only Genuine Eureka paper bags, belts, and parts in my Eureka vacuum cleaner?

A: Using Genuine Eureka Products, which are made to exacting specifications and engineered with emphasis on quality, performance, and customer satisfaction, ensures the long life and cleaning efficiency of your vacuum cleaner. Overall, this saves you money and helps to keep your home clean.

Q: How can I be sure I am using only genuine Eureka products in my vacuum cleaner?

A: Typically, packaged products and paper bags can be identified by a "Genuine Eureka Product" symbol (see illustration above). For further identification assistance, you may call our toll-free number, 1-800-282-2886, for the location of a nearby Eureka Authorized Warranty Station.











Q: Are there any differences between "made to fit" or "imitation" and Genuine Eureka paper bags, belts, and parts?

A: Yes, there are some very important differences in materials, quality, and reliability. Many customers have mistakenly purchased "imitation" paper bags and parts while thinking they purchased genuine. Unfortunately, many of these customers discovered the differences after they experienced related difficulties.

For Genuine Eureka Value, Accept No Imitations!

ELECTROLUX HOME CARE PRODUCTS NORTH AMERICA

Bloomington, Illinois 61701

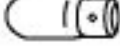
Genuine Eureka Bags, Belts and Filters Bolsas, Correas y Filtros Genuinos de Eureka		Part No. Parte No.			
	FOAM FILTER FILTRO DE ESPUMA	74077A			
	DUST CUP FILTER DCF-9 FILTRO DEL RECIPIENTE PARA POLVO DCF-9	74482			
	HEPA FILTER STYLE HF7 FILTRO HEPA ESTILO HF7	61850			
	EXTENDED LIFE BELT STYLE U CORREA DE VIDA EXTENDIDA ESTILO U	61120B			
Accessories / Accesorios					
	NESTED WANDS (STRAIGHT & CREVICE) TUBOS ENCAJADOS (DERECHOS Y PARA HENDIDURAS)	71492A			
	COMBINATION BRUSH CEPILLO COMBINADO	60990-2			
	TURBO NOZZLE BOQUILLA TURBO	75391			
	TELESCOPIC DUSTER QUITA POLVO PLEGADIZO	74123-1			
Hoses / Mangueras					
	STAIR HOSE MANGUERA PARA ESCALONES	60038-8			
Brush Roll (IMPORTANT: Be sure to note model number when ordering.) Cepillo circular (IMPORTANTE: Asegúrese de tener a mano el número del modelo cuando hace su pedido)					
	13" BRUSHROLL ASSY W/EDGE KLEENER MODEL 2941AVZ, 2940AV	60844-7			
	ENSAMBLAJE DEL CEPILLO CIRCULAR DE 13 PULGADAS CON EDGE KLEENER PARA EL MODELO 2941AVZ, 2940AV				
	15" BRUSHROLL ASSY W/EDGE KLEENER MODEL 2971BVZ, 2972AV	62365-2			
	ENSAMBLAJE DEL CEPILLO CIRCULAR DE 15 PULGADAS CON EDGE KLEENER PARA EL MODELO 2971BVZ, 2972AV				
Miscellaneous Parts / Piezas misceláneas					
	HEADLIGHT FOCO DE LUZ FRONTAL	57940-2			