

This Owner's Manual is provided and hosted by [Appliance Factory Parts](#).



Perfect Flame SLG2006B Owner's Manual

[Shop genuine replacement parts for Perfect Flame
SLG2006B](#)



[Find Your Perfect Flame Grill Parts - Select From 45 Models](#)

----- Manual continues below -----



ITEM # 13133

4-Burner LP Gas Grill

WARNING

Improper installation, adjustment, alteration, service or maintenance can cause injury or property damage.

Read the assembly, operation and maintenance instructions thoroughly before assembling or servicing this equipment.

DANGER

Failure to follow these instructions could result in fire or explosion that could cause property damage, personal injury or death.

DANGER

DO NOT use gas grill for indoor cooking or heating. TOXIC fumes can accumulate and cause asphyxiation. DO NOT use in or on boats or recreational vehicles.

PROP 65 WARNING

Chemicals known to the state of California to cause cancer, birth defects or other reproductive harm are created by the combustion of liquid propane gas.



WARNING FOR YOUR SAFETY:

For Outdoor Use Only.
(outside any enclosure)

SAVE THESE INSTRUCTIONS FOR FUTURE REFERENCE. IF YOU ARE ASSEMBLING THIS UNIT FOR SOMEONE ELSE, GIVE THIS MANUAL TO HIM OR HER TO SAVE FOR FUTURE REFERENCE.

FOR CUSTOMER SERVICE, EMAIL TO SERVICE@PYROMAGICBBQ.COM OR CALL 1-877-885-8227 (TOLL-FREE), 6 A.M. – 5 P.M.(PST), MONDAY-FRIDAY.

Printed in China

Grill Operation Quick Reference

Before Grilling.

- Step 1 Keep your grill a safe distance away from your property.*
- Step 2 Always Perform a Leak Test on all connections and hoses.*
- Step 3 Keep children away from the grill.

During Grilling.

(To avoid tripping safety valves, please follow these instructions carefully!)

- Step 1 First open lid and turn gas valve on slowly.
- Step 2 Turn only one knob on at a time when lighting up the grill.
- Step 3 Use protective gloves when grill gets hot.

After Grilling.

- Step 1 Burn grill for 10-15 minutes to burn off food residues.
- Step 2 Wait until the grill is completely cooled before closing lid.
- Step 3 Clean up grease build-up and cover your grill.

* Please refer to the owner's manual for details.

SPECIAL WARNINGS

1. DO NOT store or use gasoline or other flammable vapors and liquids within 25 feet of this or any other appliance.
2. When cooking with oil/grease, do not allow the oil/grease to exceed 350°F (177°C).
3. Do not store or use extra cooking oil in the vicinity of this or any other appliance.
4. When using rotisserie burner, DO NOT turn on main burners. (if applicable)
5. If you smell gas:
 - Shut off gas to the appliance.
 - Extinguish any open flames.
 - Open lid.
 - If odor continues, immediately call your gas supplier or fire department.

Always read and understand the **WARNINGS** and **INSTRUCTIONS** that are contained in this manual before attempting to use this gas barbecue grill, to prevent possible bodily injury or property damage.

Table of Contents

For Your Safety	3
Illustrated Parts List	5
Hardware List	6
Assembly Instructions	7
Operating Your Grill	14
Propane tank Connection	15
Checking for Leaks	15
Lighting Your Grill	15
Excess flow safety valve reset procedure	17
Care and Maintenance	18
Award Winning Barbecue Recipes	19
Troubleshooting	20
Warranty Program	22

For Your Safety

Dear Valued Customer,

Congratulations on your new barbecue grill purchase! You've made the right choice. In this manual, you will find assembly instructions, suggestions for grilling and helpful hints, as well as guidelines for the safe operation, proper care and use of your grill. Our expert staff strives to provide you with an easy to assemble product. Should you have any questions or problems with this product, please email us at service@pyromagicbbq.com or call our customer service department at 1-877-885-8227, 6:00 am - 5:00 pm (PST), Monday through Friday.

NOTE: The use and installation of this product must conform to local codes. In absence of local codes, use the National Fuel Gas Code, ANSI Z223.1/NFPA 54, Storage and Handling of Liquefied Petroleum Gases, ANSI/NFPA 58 or CSA B149.1, Natural Gas and Propane Installation Code.

IMPORTANT NOTICE: READ ALL INSTRUCTIONS PRIOR TO ASSEMBLY AND USE

Safety First!

Read and understand all warnings and precautions prior to operating your grill.

WARNING

1. This grill is for outside use only. It should not be used in a building, garage or any other enclosed area.
2. The use of alcohol, prescription or non-prescription drugs may impair an individual's ability to properly assemble or safely operate this appliance.
3. Always open the grill lid carefully and slowly as heat and steam trapped within the grill could cause severe burns.
4. Always place your grill on a hard and level surface far away from combustible materials and structures. An asphalt or blacktop surface may not be acceptable for this purpose.
5. Do not leave a lit grill unattended.
6. Keep children and pets away from the grill at all times.
7. This is not a tabletop grill. Do not place this grill on any type of tabletop surface.
8. Do not use the grill in high winds.
9. This grill must be used with propane gas only.
10. Do not attempt to attach this grill to the self-contained propane system of a camper, trailer, motor home or house.
11. Do not use charcoal or lighter fluid.
12. Do not use gasoline, kerosene or alcohol for lighting. The LP-gas supply cylinder must be constructed and marked in accordance with the specifications for propane gas cylinders of the U.S. Department of Transportation (DOT) CFR 49.
13. This outdoor gas appliance is not intended to be installed in or on recreation vehicles and/or boats.
14. Do not attempt to move the grill while it is lit.
15. Do not use the grill unless it is **COMPLETELY** assembled and all parts are securely fastened and tightened.
16. Keep combustible items and surfaces at least 24 inches away from the grill at all times. **DO NOT** use this gas grill or any gas product under any overhead enclosure or near any unprotected combustible constructions.
17. Do not use in an explosive atmosphere. Keep grill area clear and free from combustible materials, gasoline and other flammable vapors and liquids.
18. Do not attempt to use or assemble with missing or damaged parts. Contact customer service for a replacement.

CAUTION-Prevention of Burns

1. To avoid burns, do not touch metal parts of the grill until they have completely cooled for at least 45 minutes or unless you are wearing protective gear such as pot holders, gloves, BBQ mittens, etc.
2. Do not alter the grill in any manner.
3. Clean and inspect the hose before each use. If there is evidence of abrasion, wear, cuts or leaks, the hose must be replaced prior to operation. The replacement hose assembly should be in accordance with the manufacturer's specifications.
4. Move gas hoses as far away as possible from hot surfaces and dripping hot grease.
5. Never keep a filled gas container in a hot car or car trunk. Heat will cause the gas pressure to increase, which could open the relief valve and allow gas to escape.

Safe Locations for Use of This Outdoor Grill

DANGER

Never use this outdoor grill inside any building, garage, shed or breezeway, or inside any boat, trailer or recreational vehicle, to prevent a possible fire and to prevent the possibility of carbon monoxide poisoning or asphyxiation.

WARNINGS

Do not use this appliance under an overhead combustible surface or covered area (e.g., awnings, umbrellas, porches or gazeboes).

Always confirm that this grill is not positioned under the overhang of a house, a garage or other structure before lighting it. An overhang will serve to deflect flare-ups and radiated heat into the structure itself, which could result in a fire.

Always confirm that this grill is positioned more than 24 inches (61 cm) away from any combustible materials or surface before lighting it, and that no gasoline or other volatile substances are stored in the vicinity of this grill. The temperature of a grease fire or of the radiated heat might otherwise be sufficient to ignite nearby combustible or volatile substances. (As the fig. shown on right).

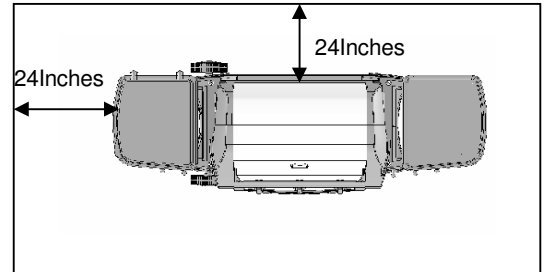

Always locate this grill where there will be ample combustion and ventilation air, but never position it in the direct path of a strong wind.

Never allow the grill to operate while unattended, to prevent uncontrolled grease fires from erupting.

Never attempt to move this grill while it is in operation or while it is still hot, to prevent possible personal injury.

Never store or use gasoline or other flammable or volatile substances in the vicinity of this grill or in the vicinity of any other heat-generating appliance, because of the danger of starting a fire.

Always confirm that the installation of this grill conforms with the requirements of all local codes or, in the absence of applicable local codes, with either the National Fuel Gas Code, ANSI Z223. NFPA 54 or CAN/CGA-B149.2, Propane Installation Code.

DANGER – Gas Safety

Liquid propane (LP) gas is flammable and hazardous if handled improperly. Become aware of its characteristics before using any propane product.

- Propane Characteristics: Flammable, explosive under pressure, heavier than air and settles in pools in low areas.
- In its natural state, propane has no odor. For your safety, an odorant has been added.
- Contact with propane could cause freeze burns to the skin.
- This grill is shipped from the factory for propane gas use only.
- Never use a propane cylinder with a damaged body, valve, collar or footing.
- Dented or rusted propane cylinders may be hazardous and should be checked by your propane gas supplier.

CAUTION

- It is essential to keep the grill's valve compartment, burners and circulating air passages clean.
- Inspect the grill before each use:

Step 1 Inspect all hoses and connections and make certain they are secure.

Step 2 Check and clean the burner venturi tubes for insects and insect nest by removing the burner and inserting a bottle brush into each tube to make sure the passage is clear.

*** A clogged tube can lead to a fire beneath the grill.



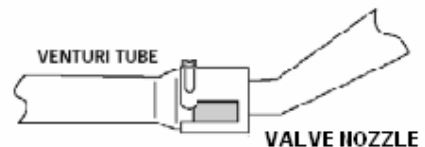











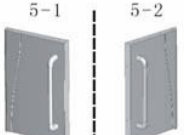



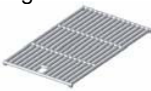

Step 3 Ensure that the valve nozzle is pointing straight and completely inserted into the venturi tube.















GENERAL INFORMATION

1. A propane gas cylinder is required for operation.
2. This gas grill is NOT intended for commercial use.

Illustrated Parts List

<p>1. Right Side Panel-----1pc</p> 	<p>2. Left Side Panel-----1pc</p> 	<p>3. Bottom Panel-----1pc</p> 	<p>4. Back Panel-----1pc</p> 
<p>5. Cart Front Beam-----1pc</p> 	<p>6. Door-----2pcs</p> <p>5-1 5-2</p> 	<p>7. Drawer-----1pc</p> 	<p>8. Body Assembly-----1pc</p> 
<p>9. Right Side Shelf-----1pc</p> 	<p>10. Side Burner Shelf -----1pc</p> 	<p>11. Side Burner Assembly-----1pc</p> 	<p>12. Heat plate-----4pcs</p> 
<p>13. Cooking Grid-----2pcs</p> 	<p>14. Warming Rack-----1pc</p> 	<p>15. Grease Pan -----1pc</p> 	<p>16. Cup Support-----1pc</p> 
<p>17. Grease Cup-----1pc</p> 	<p>18. Tank Clip-----1pc</p> 	<p>19. Rotisserie Motor Support -----1pc</p> 	<p>20. Side Burner Knob-----1pc</p> 
<p>21. Side Knob Support-----1pc</p> 	<p>22. Basket-----1pc</p> 		

Hardware List

A		M6x15mm Bolts	6pcs	B		M6x20mm Bolts	4pcs
C		M6 x45 mm Bolts	4pcs	D		Spring Washers	14pcs
E		M6 Washers	14pcs	F		M4x12mm Bolts	4pcs
G		M4 Washers	6pcs	H		M4 Nuts	3pcs
I		M4x16 mm Bolts	2pcs	J		M6 Nuts	2pcs
K		M4 x29 mm Screw Studs	1pc	L		Screwdriver	1pc

Hardware listed above is not scaled to exact size
(A screwdriver is included for your convenience.)

Assembly Instructions

Remove all contents from the carton packaging. Make sure all parts are present before attempting assembly. Once the grill is fully assembled, go back and check to make certain all the bolts are tight. Tighten again with the screwdriver provided if it is necessary.

Estimated Assembly Time: It will take less than 40 minutes to assemble the grill.

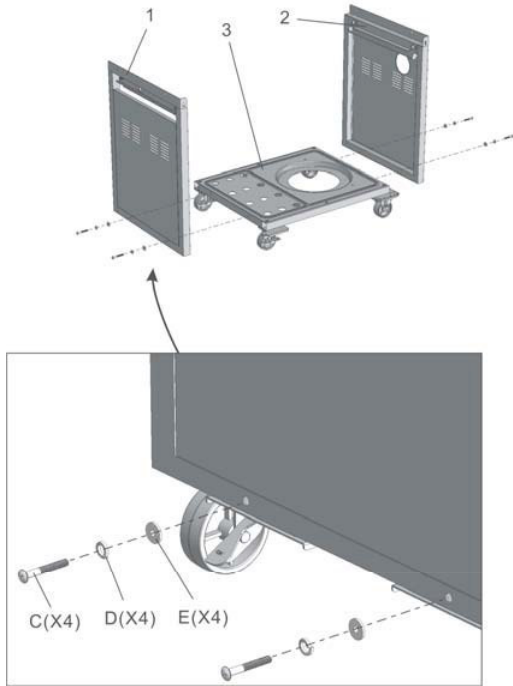

Step 1

Note: Before beginning assembly, make certain the wheels of the cart assembly are locked.
Align the holes at the bottom of the right side panel (1) with the holes on the right side of the bottom panel (3). Insert a M6x45mm bolt (C), a spring washer (D) and a M6 washers (E) into each pre-drilled hole. Tighten by hand until secure. Repeat the procedure for the left side panel (2). Go back to tighten all the bolts with the screwdriver provided.

Step 2

Loosen four back panel bolts (pre-attached) and insert the back panel (4). Tighten four panel bolts by hand until secure. Go back to tighten all the bolts with the screwdriver provided.

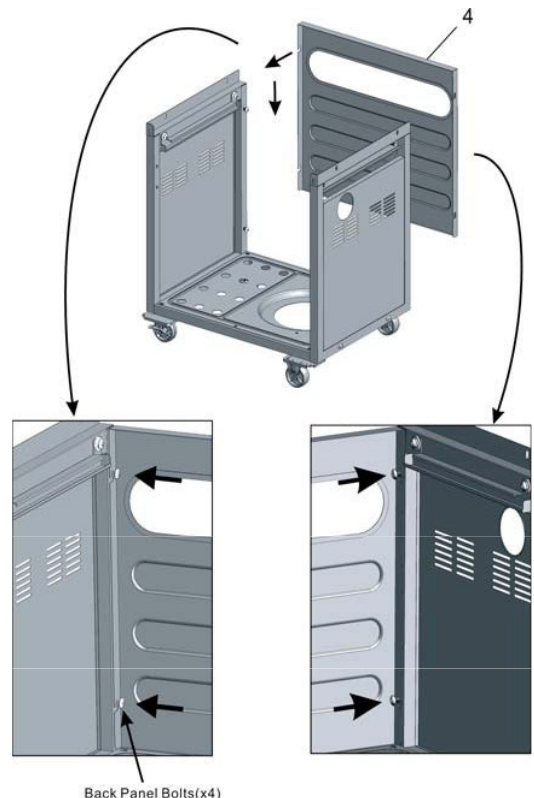

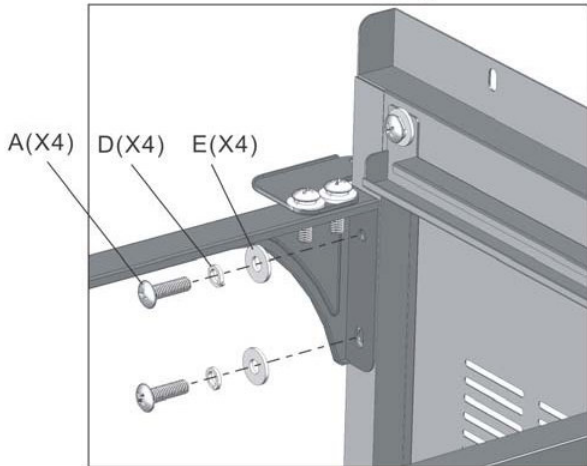
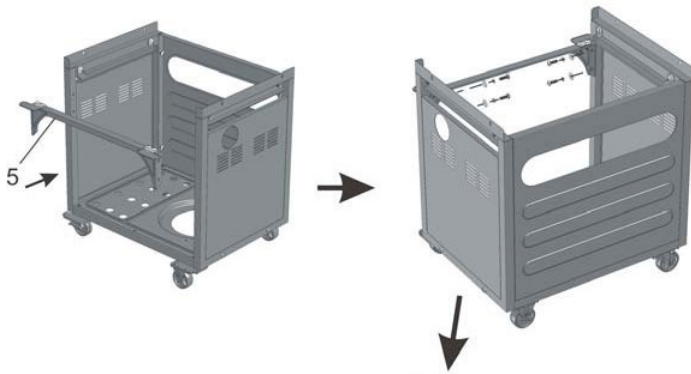

Step 3

Place the cart front beam (5) in front of the cart assembly.
 Align the holes on the inside rim of the right side of the cart assembly with the holes on the cart front beam.
 Insert a M6x15mm bolt (A), a spring washer (D) and a M6 washer (E) into each hole.
 Tighten by hand until secure.
 Repeat the procedure for left side of the cart front beam.
 Go back to tighten all the bolts with the screwdriver provided.

Step 4

Slide the basket (22) onto the slots on the right door (6-1).
 First Step: Insert the pin on the bottom of the right door into the hole at the right bottom of the cart assembly.
 Second Step: Insert the pin on top of the right door in the right side of the cart front beam.
 Repeat the same procedure for the left door (6-2).

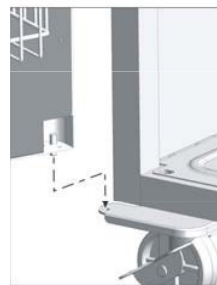
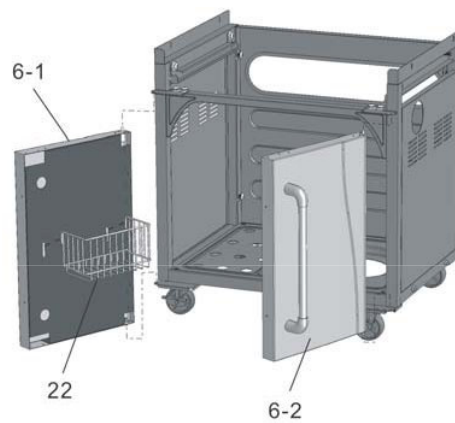

First Step

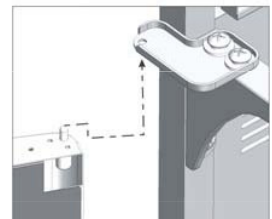

Second Step

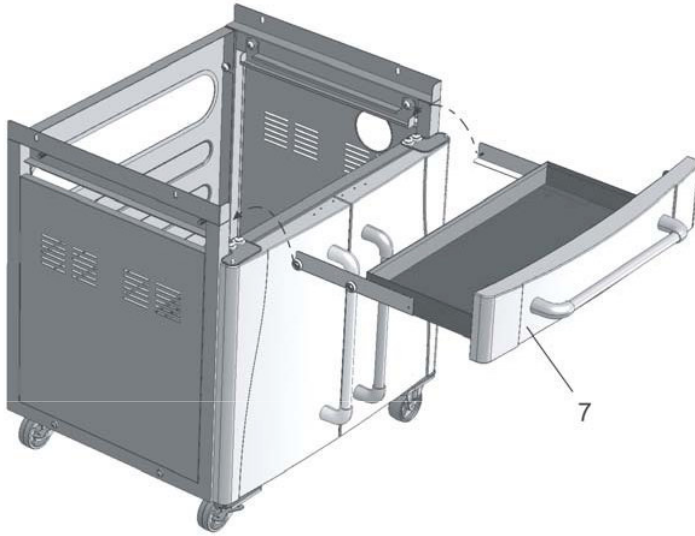

Step 5

Align the rollers of the drawer (6) with the drawer guides.
Slide the drawer into the cart assembly.

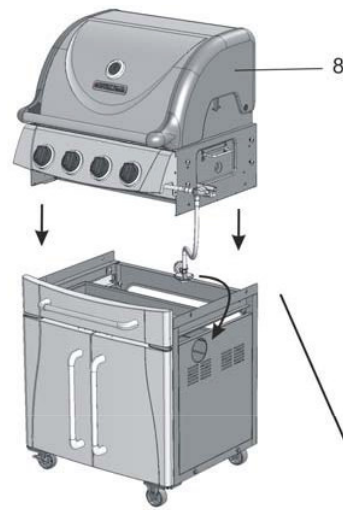

Step 6

Place the body assembly (8) on top of the cart.

Note: Make certain the pre-drilled holes on the left sides of the body assembly are properly aligned.

Insert a M6x20mm bolt (B), a spring washer (D) and a M6 washer (E) into each hole on left sides of the body assembly.

Tighten by hand until secure.

Repeat the procedure for right side of the body assembly.

Go back to tighten all the bolts with the screwdriver provided.

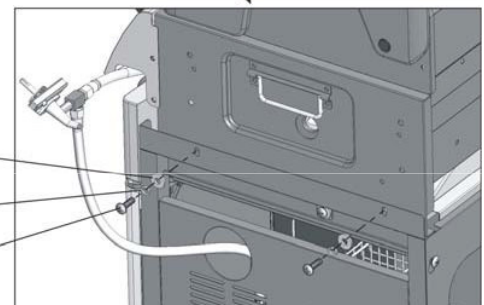

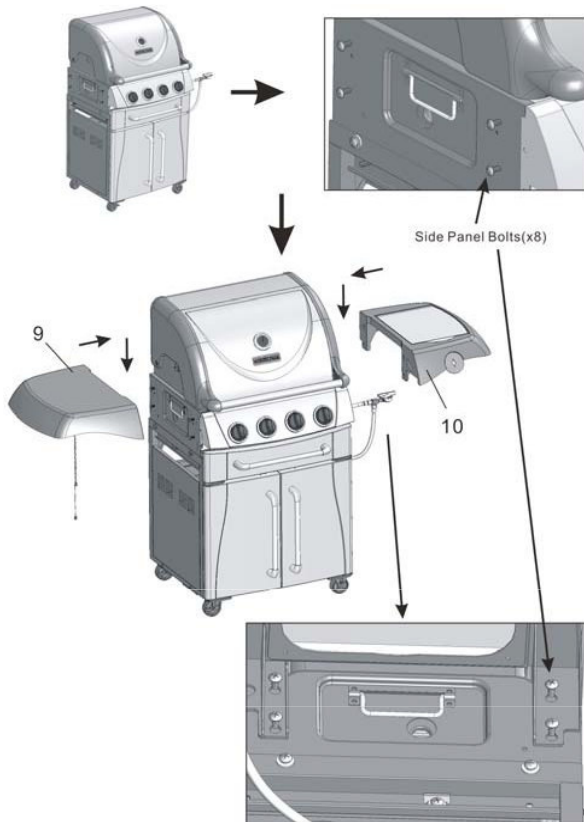

Step 7

Loosen the four side panel bolts (pre-attached) on the right side of the body assembly and allow ¼ bolt length to extend from the body.

Align the large holes of the right side shelf (9) with the bolts extended from the body assembly.

Push down until the shelf locks into place.

Tighten bolt connections by hand until secure.

Repeat the same procedure for the left side shelf (10).

Go back to tighten all the bolts with the screwdriver provided.

Step 8

Align the holes on side knob support (21) with the holes on the left side shelf and side burner valve. Make certain the base of the valve shaft is flush with the side knob support. Screw a M4x16mm bolt (I) and a M4 washer (G) into each pre-drilled hole.

Tighten the bolts with the screwdriver provide. Insert the side burner knob (20) into knob shaft on valve.

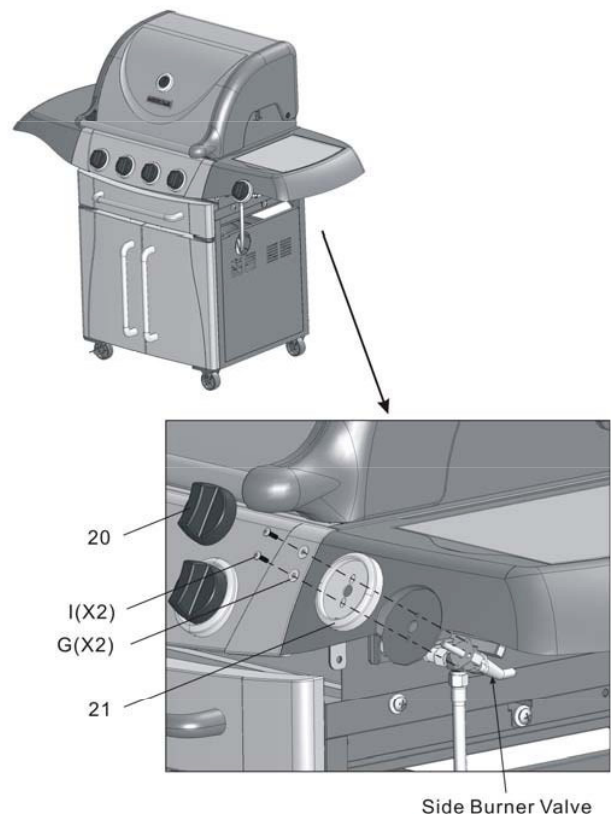

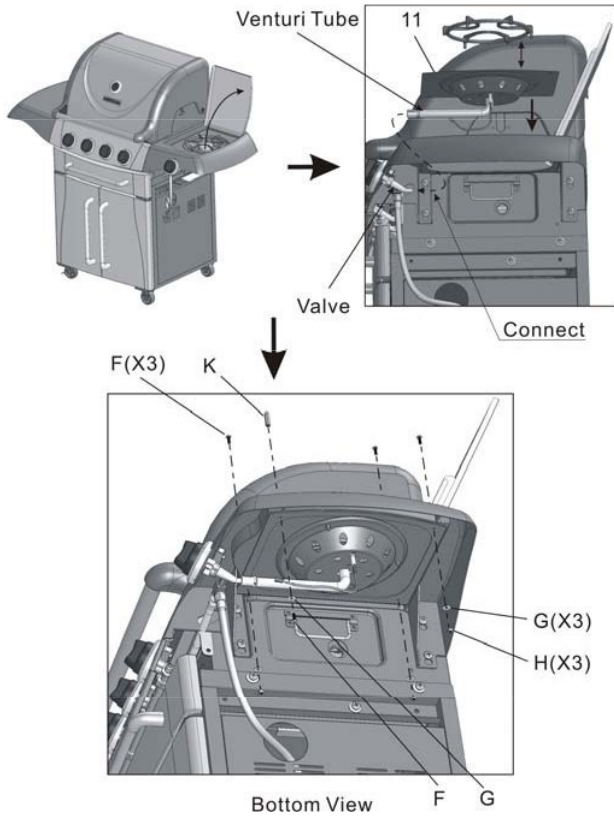

Step 9

Open the side burner lid and place the side burner set (11) on the left side shelf. Make certain the venturi tube is connected properly with the valve. Align the holes on the side burner assembly with the holes on the left side shelf. Insert a M4x12mm bolt (F) and a M4 washer (G) from under side into the most left front pre-drilled hole and screw into the M4 x 30 stud (K) by hand. Insert three M4x12mm bolts (F) from top side into the other three pre-drill holes. Insert the M4 washers ((G) on the bolts end and screw the M4 nuts (H) into bolts by hand. Go back to tighten all the bolts with the screwdriver provided.

Step 10

Connect the ignition cable with the electrode. Make certain the connection is secure.

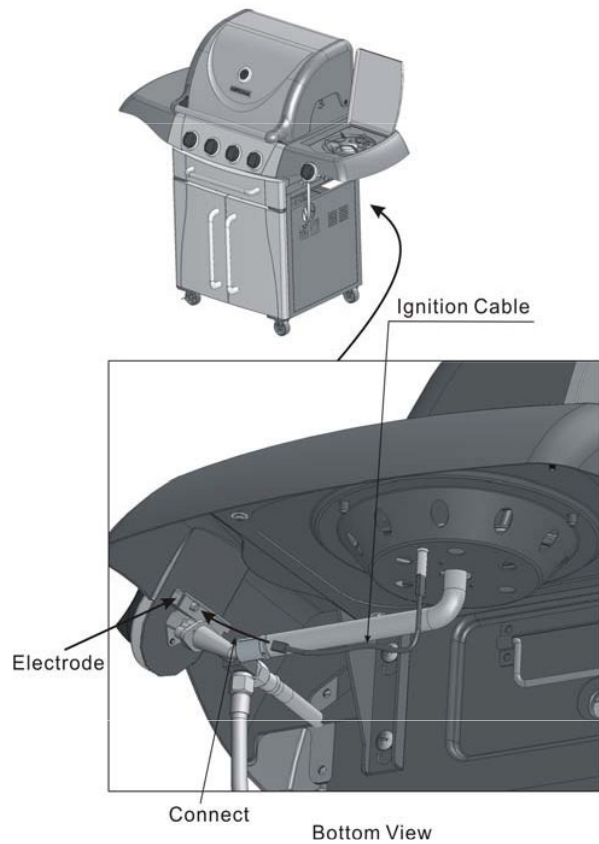

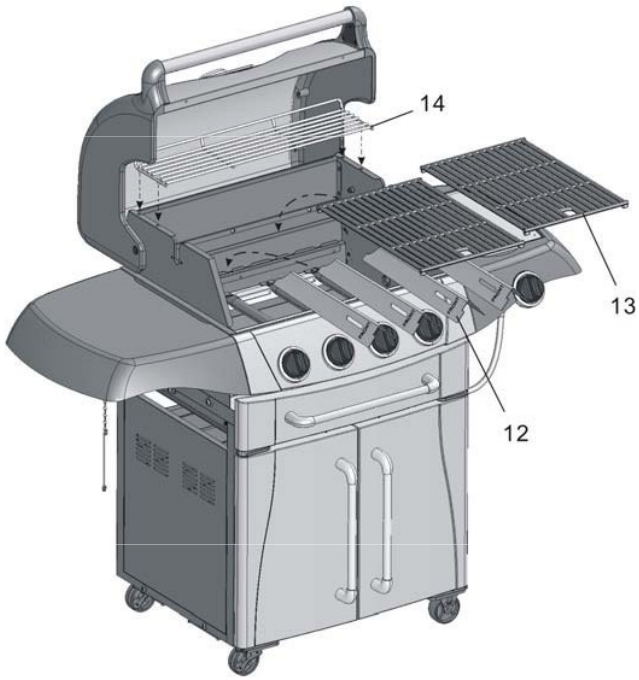

Step 11

Place the four heat plates (12) inside the grill upon the burners.
 Place the two cooking grids (13) inside the grill upon the heating shields.
 Insert the four ends of warming rack (14) into the holes on top of grill body.

Step 12

Align the holes on the rotisserie motor support (19) with the holes on the right side of the grill body.
 Insert a M6x15mm bolt (A) into each hole.
 Insert a M6 washer (E), a spring washer (D) and a M6 nut (J) into end of each bolt.
 Tighten all the bolts with nuts with the screwdriver provided.

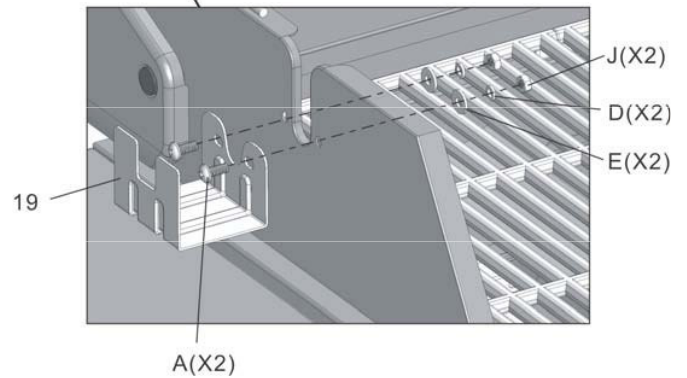

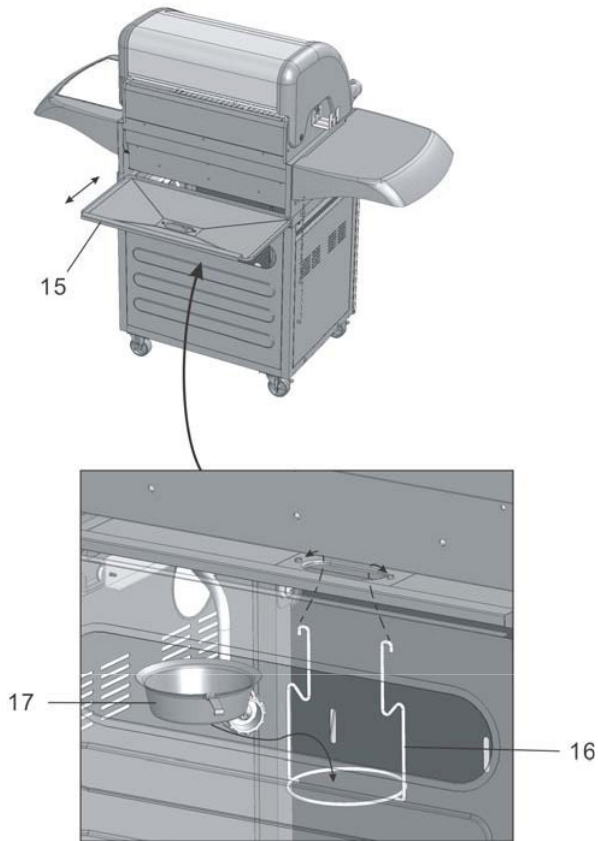

Step 13

Slide the grease pan (15) into the back of the cart assembly.

Hook the cup seat (16) into the grooves beneath the grease pan.

Place the grease cup (17) on the cup support.

Step 14

Insert the clip (18) into the holes on the bottom panel.

Place the gas tank on the tank support and clip it with the clip.

Connect the tank with regulator by screwing the collar onto the tank valve.

(See diagram below)

Make certain they are connected securely.

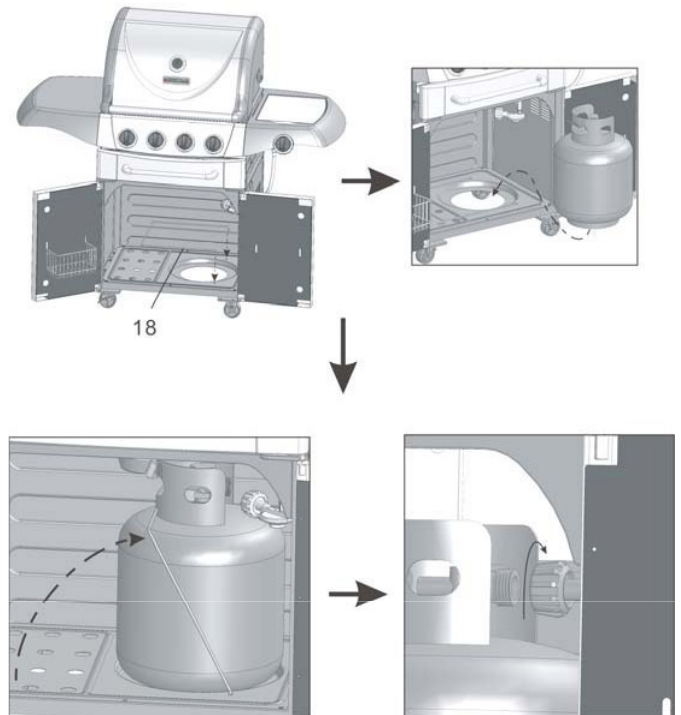

Fully Assembled View



Operating the Grill

CAUTION:

Use only the regulator provided. If a replacement is necessary, call our customer service center. The use of unauthorized parts can create an unsafe condition and environment.

The propane gas supply cylinder used must be constructed and marked in accordance with the *Specifications for Propane Gas Cylinders* of the U.S. Department of Transportation (DOT). Only cylinders with a listed overfill prevention device (OPD) and marked "propane" may be used. Cylinders with an OPD will have valve handles with three "lobes" (prongs).

The pressure regulator and hose assembly supplied with the outdoor cooking gas appliance must be used. Replacement pressure regulators and hose assembly must be those specified by the outdoor cooking gas appliance manufacturer. Only use 20 pound cylinders equipped with a cylinder connection device compatible with the connection for outdoor cooking appliances. The cylinder must include a collar to protect the cylinder valve. The gas cylinder should not be dropped or handled roughly. If the appliance is not in use, the gas cylinder must be disconnected.

Storage of the appliance indoors is permissible ONLY if the cylinder is disconnected and removed from the appliance. Cylinders must be stored outdoors and out of the reach of children. Cylinder must not be stored in a building, garage or other enclosed area. Your cylinder must never be stored where temperatures can reach over 125F.

Before connecting, make sure there is no debris caught in the head of the gas cylinder, regulator valve or in the head of the burner and burner ports. Connect regulator valve and hand tighten firmly. Disconnect the propane cylinder from the regulator valve when the grill is not in use. DO NOT obstruct the flow of combustion air or ventilation air to the grill. The propane cylinder must be arranged for vapor withdrawal and equipped with a listed overfill prevention device (OPD).

Danger: A fire causing death or serious injury may occur if the following is not followed exactly:

Never store or use gasoline or other volatile substance in the vicinity of this grill.

Never store a spare propane cylinder in the vicinity of this grill, or in the vicinity of another potential heat source.

Never fill the propane cylinder beyond 80% full.

Warning: Do not store spare gas cylinder in or near grill.



LP (Propane) Gas Supply Connection

1. Always place the propane cylinder on the designated tank support area of the grill.
2. Always confirm that all burner control knobs are in the OFF position before activating the gas supply.
3. Before connection, be sure that there is no debris caught in the head of the gas cylinder, head of the regulator valve, or in the head of the burner and burner ports.
4. Always connect the gas supply regulators as follows:
Insert the nipple of the valve coupling into the tank valve and tighten the connection collar by turning it clockwise with one hand while holding the regulator with the other. (As in the fig. shown on right)
5. Disconnect the propane cylinder from the regulator valve when the grill is not in use.
6. Do not obstruct the flow of combustion air and ventilation air to the grill.

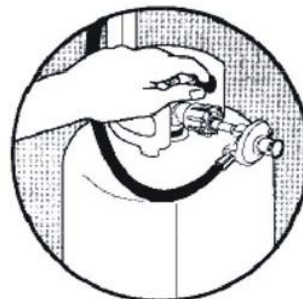

DANGER

To prevent fire or explosion hazard when testing for a leak:

1. Always perform the "leak test" before lighting the grill and each time the cylinder is connected for use.
2. Do not smoke or allow other sources of ignition in the area while conducting a leak test.
3. Conduct the leak test outdoors in a well-ventilated area.
4. Do not use matches, lighters or a flame to check for leaks.
5. Do not use grill until all leaks have been stopped, if you are unable to stop a leak, disconnect the propane supply, and call for gas appliance service or your local propane gas supplier.

Checking for Leaks

1. Make a 2-3 oz. of leak solution by mixing one part liquid dishwashing soap with three parts water.
2. Make sure control knobs are in the "OFF" position.
3. Spray some solution on all connections and hoses. (As the fig. shown on right).
4. Open the cylinder valve.
5. Inspect the solution, looking for bubbles. If no bubbles appear, the connections and hoses are secure.
6. If bubbles appear, you have a leak. Go to step 7.
7. If bubbles appear on the hose, contact the customer service center and get a replacement.
8. If bubbles appear at a connection point, disconnect and reconnect, making sure the connection is secure.
9. Retest with solution.
10. If you continue to see bubbles, contact the customer service center.



Lighting Your Grill

Danger: Failure to open lid while igniting the barbecue's burners or not waiting 5 minutes to allow gas to clear if the barbecue does not light, may result in an explosion, which could cause serious bodily injury or death.

WARNING: Never stand with your head directly over the grill when preparing to light the main burners, to prevent possible bodily injury.

Main Burner

1. Open lid while lighting burners.
WARNING: Attempting to light the burner with the lid closed may cause an explosion. Make sure there are no obstructions of airflow to the gas unit. Spiders and insects can nest and clog the burner/venturi tube at the orifice. A clogged burner tube can lead to a fire beneath the appliance.
2. All control knobs must be in the "OFF" position.
3. Open cylinder valve.
4. Ignite only the burners you wish to use, using the same method for each:
Push desired burner control knob and rotate slowly about 1/4 counter-clockwise until a click is heard. The burner should light. If the burner does not light, return the control knob to the "OFF" position immediately. Wait five minutes for the gas to clear and repeat the procedure. After burner is lit, repeat the procedure with any other burner desired.
5. Adjust control knob(s) to desired cooking temperature.

Using the Lighting Stick to Light the Main Burners

1. Remove the cooking grid and heat plate from the burner you wish to light.
2. Insert a match into the end of lighting stick. Light the match.
3. Once lit, place the flame through the hole on grill body to reach the burner ports. (As in the fig. shown on right).
4. Press the control knob and rotate it counter clockwise to the "HIGH" position. The burner should light immediately. To light up other burners, repeat the same procedure for the adjacent burner and continue in sequence until all desired burners are lit.
5. Replace cooking grid and heat plate and adjust burners to the desired cooking temperature.

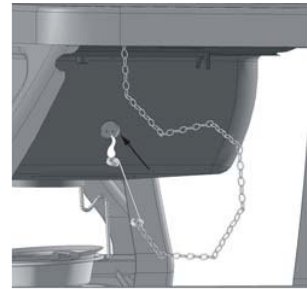

Precautions

1. After lighting, please observe the burner flame. Make sure all burner ports are lit.
2. If the burner flame goes out during operation, immediately turn the gas "OFF". Open lid to let the gas clear for at least 5 minutes before re-lighting.
3. Before cooking on the grill for the first time, operate the grill for approximately 15 minutes with the lid closed and the gas turned on "HIGH". This will "heat clean" the internal parts, dissipate odor from the manufacturing process and painted finish.
4. Clean the grill after each use. DO NOT use abrasive or flammable cleaners. This may damage parts of the grill and cause a fire.

Side Burner

1. Open lid while lighting the burner. Lid must remain open while burner is lit.
2. Control knob must be in the "OFF" position.
3. Open cylinder valve.
4. Push side burner knob fully and rotate it slowly about 1/4 counter-clockwise until a click is heard. The burner should light. If the burner does not light, turn the knob to the "OFF" position immediately. Wait five minutes for the gas to clear and repeat the procedure.
5. Adjust valve knob to the desired cooking temperature.

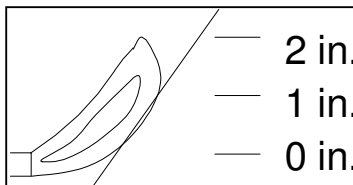

**Observe flame height when lit:
Flame should be a blue/yellow color between 1 to 2 inches high.**

Confirm that the burner is properly lit and that the flame pattern is as desired, (see fig. A, B and C below for the proper flame patterns). If the flame pattern is other than normal, consult the troubleshooting guide in the manual for corrective action.

FIG. A

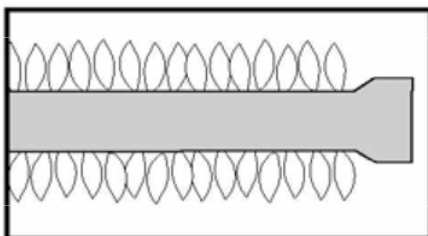

Normal: Soft blue flames with yellow tips between 1 inch - 2 inches high.

FIG. B

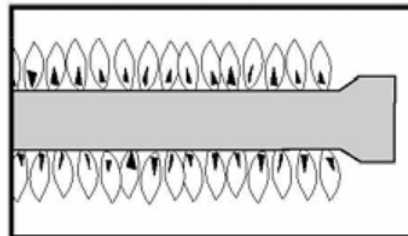

Out of adjustment: Noisy hard blue flames – too much air.

FIG. C

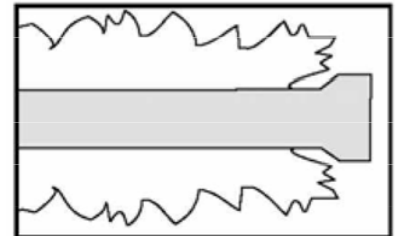

Poor combustion: Wavy, yellow flames- too little air.

Flare-ups

“Flare-ups” sometimes occur when food drippings fall onto the hot heat plate(s) or burner(s) and ignite. Some flaring is normal and desirable, as it helps impart the unique flavors associated with grilled foods. Controlling the intensity of the flare-ups is necessary, however, in order to avoid burned or unevenly cooked foods and to prevent the possibility of accidental fire.

WARNING: Always monitor the grill closely when cooking and turn the flame level down (LOW) or OFF, if flare-ups intensify.

Shutting Off Burners

- Always turn the control knob(s) clockwise to the “HIGH” position, then press and turn to “OFF”. Never force the knob without pressing it. This could damage the valve.
- Promptly turn the gas supply to the “OFF” position at the propane cylinder.
- Allow grill to completely cool and then close the lid of the grill.

Excess flow safety valve reset procedure

- The new regulators are equipped with a safety device that restricts the gas flow in the event of a gas leak. However, unsafe practices of grill operation could activate the safety device without having a gas leak.
- A sudden shut off of the gas flow typically occurs if you open the LP tank valve rapidly, or if one or more of the burner control knobs is in an open position when opening the LP tank valve.
- This procedure is effective with all LP Tank sizes as well as Natural Gas. When performing the procedure on a Natural Gas model, simply substitute "Natural Gas valve" for "LP Tank".
- To ensure the procedure is performed safely and successfully, please carefully follow the instructions below.
 1. Close the LP tank valve.
 2. Turn all burner control knobs to the OFF position.
 3. Disconnect the regulator from the LP tank.
 4. Open the lid of the grill.
 5. Turn burner control knobs to HIGH.
 6. **Wait at least 1 minute.**
 7. Turn burner control knobs OFF.
 8. **Wait for at least 5 minutes.**
 9. Re-connect the regulator to the LP tank.
 10. **SLOWLY** turn the LP tank valve a ¼ turn at a time and have the valve all the way open.
 11. **With the lid open**
 - For BBQ with an ignitor **button**: **ONLY** turn on **ONE** front burner control knob to the HIGH position. Ignite the grill by pushing the ignition button.
 - For BBQ with an **automatic ignition**: Push down the control knob you want to light and turn counter-clockwise until you hear the ignition click.
 12. After the first front burner is lit, turn on the other control knob(s) to the HIGH position. ****If you have more than two burners, ONLY turn them on ONE AT A TIME.**
 13. When all front burners are lit, close the BBQ lid
 14. Wait for 10-15 minutes, the temperature should reach 400 – 450 F°

Care and Maintenance

IMPORTANT

Always allow your grill to completely cool off before covering it to prevent corrosion from condensation

Caution: All cleaning and maintenance should be done when the grill is cool, with the fuel supply turned off at the control dial and the propane cylinder disconnected. DO NOT clean any grill part in a self-cleaning oven. The extreme heat will damage the finish.

Cleaning

Burning off the grill after every use (approx. 15 minutes) will keep excessive food residue from building up.

Recommended cleaning materials -

Mild dishwashing liquid detergent

Hot water

Nylon cleaning pad

Wire brush

Paper clip

Putty knife/scrapper

Compressed air

DO NOT use cleaners that contain acid, mineral spirits or xylene.

Outside surfaces

Use a mild dishwashing detergent and hot water solution to clean. Rinse thoroughly with water.

Inside surface

If the inside surface of the grill lid has the appearance of peeling paint, baked on grease has turned to carbon and is flaking off. Clean thoroughly with a strong solution of detergent and hot water. Rinse with water and allow it to completely dry.

Interior of grill bottom – Remove residue using brush, scraper and/or cleaning pad. Wash with a dishwashing detergent and hot water solution. Rinse with water and let dry.

Cooking Grids – The porcelain grates have a glass-like composition that should be handled with care. Use a nylon cleaning pad or brush and a mild dishwashing detergent or baking soda and hot water solution. Non-abrasive scouring powder can be used on stubborn stains. Rinse with water.

Heat Plates – Clean residue with wire brush and wash with soapy water. Rinse with water.

Grease Cup – Periodically empty the grease cup and clean with a dishwashing detergent and hot water solution.

Cleaning the Burner Assembly

1. Turn gas off at the control knobs and propane tank.
2. Remove cooking grids and heat plate.
3. Remove grease cup.
4. Remove burner by unscrewing nut from beneath burner “foot” using a screwdriver and pliers.
5. Lift burner up and away from the gas valve orifice.
6. Clean inlet (venturi) of burner with small bottle brush or compressed air.
7. Remove all food residue and dirt on outside of burner surface.
8. Clean any clogged ports with a stiff wire (such as an opened paper clip).
9. Inspect burner for damage (cracks or holes). If damage is found, replace with a new burner. Reinstall burner. Check to ensure the gas valve orifices are correctly positioned, pointing straight into burner inlet (venturi). Also, check position of spark electrode.

Award Winning Barbecue Recipes

Never-fail Barbecue Sauce

Ingredients:

¼ cup	Finely chopped onion
2 tablespoons	Butter or margarine
¼ cup	Brown sugar, firmly packed
1 tablespoon	Worcestershire sauce
¼ teaspoon	Hot sauce
1	Garlic clove, finely chopped
1 cup	Catsup
¼ cup	Lemon juice
1 teaspoon	Prepared mustard

Prepare:

Cook onion and garlic in margarine until tender. Add remaining ingredients and bring to a boil. Simmer uncovered 15 to 20 minutes. Refrigerate leftovers after use.

Mamma's Marinated Chicken

Ingredients:

¼ cup	Dijon mustard
2 tablespoons	Fresh lemon juice
1 ½ teaspoons	Worcestershire sauce
½ teaspoon	Dried tarragon
¼ teaspoon	Freshly ground black pepper
4	Boneless, skinless chicken breast halve

Prepare:

Combine ingredients, mixing well. Marinate chicken for several hours. Grill uncovered, over medium heat, for 10 to 15 minutes. Chicken is done when juices run clear.

Barbecued Honey Steak

Ingredients:

5 pounds	Beef sirloin steak
2 tablespoons	Red pepper -- crushed
1 teaspoon	Black pepper
2	Garlic cloves -- crushed
1 large	Onion
1 cup	Honey

Prepare:

Combine all ingredients and marinate steak for 7-8 hours. Remove meat from marinade and grill over very high heat to desired doneness.

Hardcore Grilled Trout

Ingredients:

¼ cup	Lemon or lime juice
2 tablespoons	Melted butter
2 tablespoons	Vegetable oil
2 tablespoons	Chopped parsley
1 tablespoon	Hot sauce
½ teaspoon	Ground ginger
½ teaspoon	Salt
4 brook trout -- about 1 pound each	

Prepare:

Combine lemon juice, margarine, oil, parsley, hot sauce, ginger and salt. Mix well. Pierce skin of fish in several places. Roll fish in juice mixture to coat inside and out. Cover and refrigerate 30 minutes to 1 hour, turning occasionally. Remove fish from marinade. Place fish on grill; brush fish with marinade while grilling. Cook over high heat for 5 minutes. Turn and brush with marinade. Cook 5 minutes longer. Fish is done when it flakes easily with fork.

Grilled Veggies

Ingredients:

¾ cup	Olive oil
¼ cup	Red wine vinegar
1 teaspoon	Fresh rosemary
1 teaspoon	Fresh thyme leaves
1 teaspoon	Fresh basil, chopped
1 teaspoon	Fresh oregano, chopped
1 tablespoon	Minced garlic
½ teaspoon	Salt
½ teaspoon	Ground black pepper
2 pounds assorted vegetables, chopped or whole according to taste.	

Prepare

Combine all ingredients in a small bowl. Marinate vegetables with sauce. Cover and refrigerate for 2 hrs. Grill vegetables over medium heat until tender, brushing them with marinade while they cook. Cooking times will vary according to the vegetables chosen.

Troubleshooting

Problem	Possible Cause	Prevention/Cure
Burner will not light using knobs or ignitor	Wires/or electrode covered with cooking residue.	Clean wire and /or electrode with rubbing alcohol.
	Electrode and burners are wet.	Wipe dry with cloth.
	Electrode cracked or broken – sparks at crack.	Replace electrode
	Wire loose or disconnected	Reconnect wire or replace electrode/wire assembly.
Burner will not light using a match	No gas flow	Check if propane tank is empty. If empty, replace or refill. If propane tank is not empty, refer to Excessive flow safety valve reset procedure .
	Coupling nut and regulator not fully connected.	Turn the coupling nut about one-half to three quarters additional turn until solid stop. Tighten by hand ONLY - do not use tools
	Obstruction of gas flow	Clear burner tubes. Check for bent or kinked hose.
	Disengagement of burner to valve	Reengage burner and valve
	Spider webs or insect nest in venturi.	Clean venturi.
	Burner ports clogged or blocked.	Clean burner ports.
Sudden drop in gas flow or reduced flame height.	Tank out of gas.	Check for gas in propane tank.
	Excess flow safety device may have been activated	Refer to the Excessive flow safety valve reset procedure .
Irregular flame pattern, flame does not run the full length of burner	Burner ports are clogged or blocked	Clean burner ports.
Flame is yellow or orange	New burner may have residual manufacturing oils.	Burn grill for 15 minutes with the lid closed
	Spider webs or insect nest in venturi	Clean venturi.
	Food residue, grease or seasoning salt on burner.	Clean burner.
	Poor alignment of valve to burner venturi.	Assure burner venturi is properly engaged with valve

Flame blow out	High or gusting winds	Turn front of grill to face wind or increase flame height
	Low on propane gas.	Replace or refill propane tank.
	Excess flow valve tripped	Refer to the Excessive flow safety valve reset procedure.
Flare-up	Grease buildup.	Clean grill.
	Excessive fat in meat	Trim fat from meat before grilling.
	Excessive cooking temperature	Adjust (lower) temperature accordingly.
Persistent grease fire.	Grease trapped by food buildup around burner system	Turn knobs to OFF. Turn gas OFF at propane tank. Leave lid in closed position and let fire burn out. After grill cools, remove and clean all parts.
Flashback [fire in burner tubes]	Burner and /or burner tubes are blocked.	Clean burner and/or burner tube(s)
Inside of lid is peeling – like pant peeling	The lid is stainless steel, not painted	Baked on grease buildup has turned to carbon and is flaking off. Clean thoroughly
Irregular flame	Air flow is not correct. <u>Correct flame:</u> blue with yellow tips, 1-2" high. <u>Too little air:</u> wavy yellow or orange flames. <u>Too much air:</u> noisy blue flames.	If flames are yellow or orange – open flap at the end of the venturi tubes in 1/8" increments until flames are correct. If flames are blue and noisy – close flap at the end of the venturi tubes in 1/8" increments until flames are correct. *Propane Models must be open a minimum of 1/8" *Natural Gas Models must be open a minimum of 1/16"

Warranty Program

Proof of purchase is required to access this warranty program, which is in effect from the date of purchase. Inability to provide proof of purchase or after the warranty has expired, customers will be subject to parts, shipping and handling fees.

Product Registration is required to receive full warranty coverage, which is in effect from the date of purchase. Inability to register products within ten days from the date of purchase may result in charges including parts, shipping and handling fees. Customers can register their products online at www.pyromagicbbq.com or by returning the mail-in registration card.

Limited Warranty

10 Year Warranty on stainless steel burners.

1 Year Warranty on all parts in regards to damage affecting the operation of the gas grill.

Warranty Provisions:

This warranty is non-transferable and does not cover failures due to misuse or improper installation or maintenance. This warranty is for replacement of defective parts only. We are not responsible for incidental or consequential damages or labor costs.

This warranty does not cover chips and scratches of porcelain or painted surfaces, nor does it cover corrosion or discoloration due to misuse, lack of maintenance, hostile environment, accidents, alterations, abuse or neglect.

This warranty does not cover damage caused by heat, abrasive and chemical cleaners, resulting in chipped porcelain enamel parts or any damage to other components used in the installation or operation of the gas grill.

Some states do not allow the limitation or exclusion of incidental or consequential damages, so the above limitations or exclusions may not apply to you. This warranty gives you specific legal rights, and you may also have other rights that vary from state to state.

If you have any questions related to the product or warranty, please call our customer service center at 1-877-885-8227, 6:00 AM to 5:00 PM (PST), Monday through Friday.

Manufactured by:

Lucas Innovation Inc.

Xiekeng District, QingXi Town, Dong Guan, Guang Dong, China

Printed in China