

This Owner's Manual is provided and hosted by [Appliance Factory Parts](#).

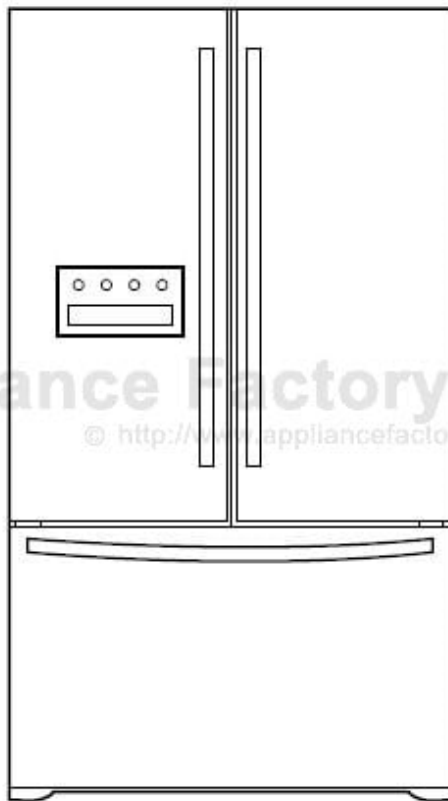

Kenmore 795.7839.801 Owner's Manual

[Shop genuine replacement parts for Kenmore
795.7839.801](#)



[Find Your Kenmore Refrigerator Parts - Select From 665 Models](#)

----- Manual continues below -----



REFRIGERATOR

SERVICE MANUAL

CAUTION
BEFORE SERVICING THE UNIT,
READ THE SAFETY PRECAUTIONS IN THIS MANUAL.

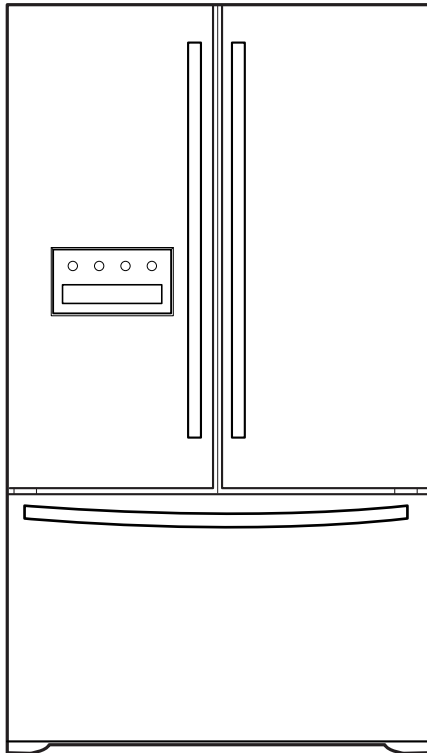

Model #s:

795.78733.801
795.78739.801
795.78743.801
795.78749.801

CONTENTS

SAFETY PRECAUTIONS	2
1. SPECIFICATIONS	3-4
2. PARTS IDENTIFICATION	5
3. DISASSEMBLY	6-14
REMOVING AND REPLACING REFRIGERATOR DOORS	6
DOOR	7-8
DOOR ALIGNMENT	8
FAN AND FAN MOTOR(Evaporator)	8
ICE FAN SCROLL ASSEMBLY REPLACEMENT	9
DEFROST CONTROL ASSEMBLY	9
LAMP	9
MULTI DUG, MAIN PWB	10
SERVICEABILITY REVIEWFOR HIDDEN DISPENSER	11-14
ICE CORNER DOOR REPLACEMEN, ICEMAKER ASSEMBLY	15
AUGER MOTOR COVER, HOW TO REMOVE THE PCB	16
HOW TO REMOVE A DOOR ICE BIN, HOW TO INSERT A DOOR ICE BIN	17
HOW TO REMOVE AND REINSTALL THE PULLOUT DRAWER	18-19
WATER VALVE DISASSEMBLY METHOD	20
FAN AND FAN MOTOR DISASSEMBLY METHOD	20
PULL OUT DRAWER	21
4. ADJUSTMENT	22-23
COMPRESSOR	22
PTC-STARTER	22
OLP(OVERLOAD PROTECTOR)	23
TO REMOVE THE COVER PTC	23
5. CIRCUIT DIAGRAM	24
6. TROUBLESHOOTING	25-62
7. COMPONENT TESTING INFORMATION	63-72

SAFETY PRECAUTIONS

Please read the following instructions before servicing your refrigerator.

1. Unplug the power before handling any electrical components.
2. Check the rated current, voltage, and capacity.
3. Take caution not to get water near any electrical components.
4. Use exact replacement parts.
5. Remove any objects from the top prior to tilting the product.

1. SPECIFICATIONS

1-1 DISCONNECT POWER CORD BEFORE SERVICING IMPORTANT – RECONNECT ALL GROUNDING DEVICES

All parts of this appliance capable of conducting electrical current are grounded. If grounding wires, screws, straps, clips, nuts or washers used to complete a path to ground are removed for service, they must be returned to their original position and properly fastened.

1-2 IMPORTANT NOTICE

This information is intended for use by individuals possessing adequate backgrounds of electrical, electronic and mechanical experience. Any attempt to repair a major appliance may result in personal injury and property damage. The manufacturer or seller cannot be responsible for the interpretation of this information, nor can it assume any liability in connection with its use.

1-3 ELECTRICAL SPECIFICATIONS

Temperature Control (Freezer Compartment)-6°F to +8°F
 Defrost Control.....Total Comp Running Time: 7 hrs~50 hrs
 Defrost Thermostat46°F
 Electrical Rating : 115VAC, 60Hz.....7.2 A
 Maximum Current Leakage.....0.5 mA
 Maximum Ground Path Resistance0.14 Ohms
 Energy Consumption25 cu.ft. 547 kWh/yr (Energy Star)

1-4 NO LOAD PERFORMANCE CONTROL POSITION: MID/MID

And Ambient of:70°F.....90°F
 Fresh Food, °F33°F to 41°F.....33°F to 41°F
 Frozen Food, °F-4°F to +4°F.....-4°F to +4°F
 Percent Running Time35%-45%.....50°F-70°F

1-5 REFRIGERATION SYSTEM

Minimum Compressor Capacity Vacuum 21 MIN.
 Minimum Equalized Pressure
 @ 70°F 49 PSIG
 @ 90°F 56 PSIG
 Refrigerant R134a 4.76 oz.
 Compressor 956 BTU/hr

1-6 INSTALLATION

Clearance must be provided at top, sides and rear of the refrigerator for air circulation.

AT TOP 2 in
 AT SIDES 1 in
 AT REAR 1 in

1-7 REPLACEMENT PARTS

	25 cuft
	795.78733.801 795.78743.801
	795.78739.801 795.78749.801
Relay.....	6748C-0004D
Overload	6750C-0004R
Defrost Thermostat.....	6615JB2005H
Defrost Heater	5300JK1005D
Evaporator Fan Motor.....	4681JK1004E
Capacitor (Running)	0CKZZJB2012K (0CKZZJB2014B) (0CKZZJB2012H)
Compressor (Hi-Side)	TCA31748001
Evaporator (Lo-Side).....	5421JJ1003B
Condenser.....	ACG36653801
Dryer.....	5851JA2008U
Condenser Fan Motor	4681JB1029D
Temperature Control	ABQ56655301(STS) ABQ56655303(WB)
Dispenser Control	ACQ67140901(STS) ACQ67140903(WB)
Main Control	EBR41956410
Ice Fan Motor	4681JB1029E

1-8 AIR FLOW / CIRCULATION D'AIR

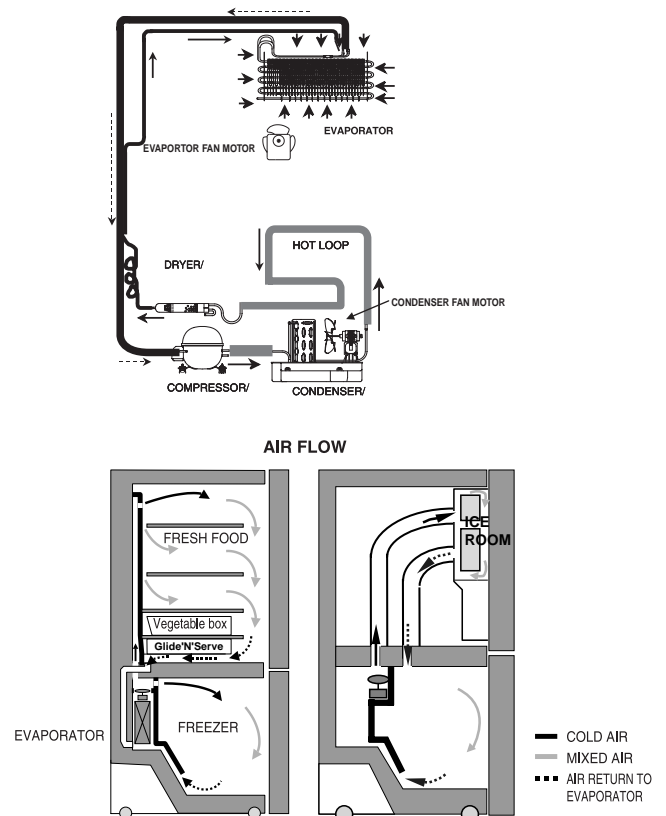

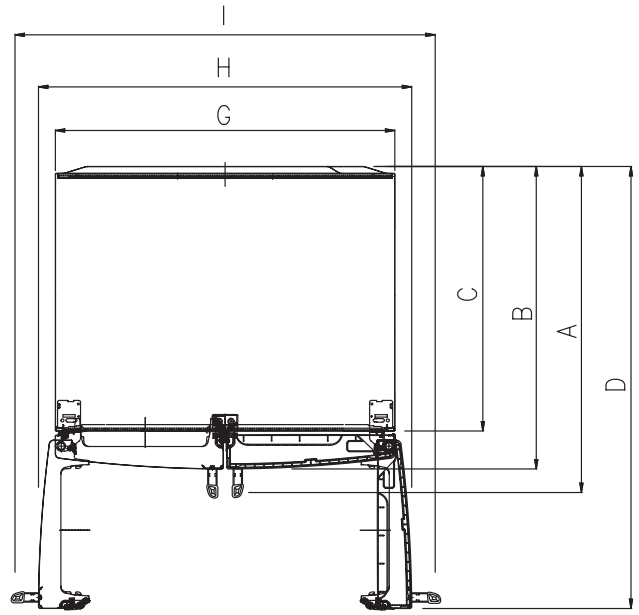
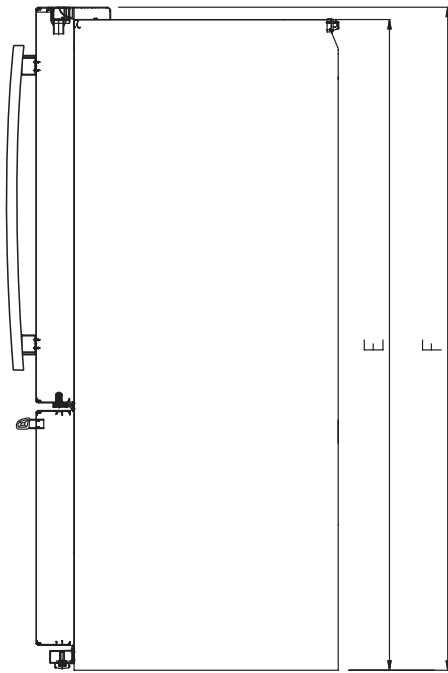

Description		795.787**
Depth w/ Handles	A	34 1/4 in
Depth w/ Handles	B	31 3/4 in
Depth w/ o Door	C	27 7/8 in
Depth (Total with Door Open)	D	46 1/2 in
Height to Top of Case	E	68 3/8 in
Height to Top of Door Hinge	F	69 3/4 in
Width	G	35 3/4 in
Width (door open 90 deg. w/o handle)	H	39 1/4 in

2. PARTS IDENTIFICATION

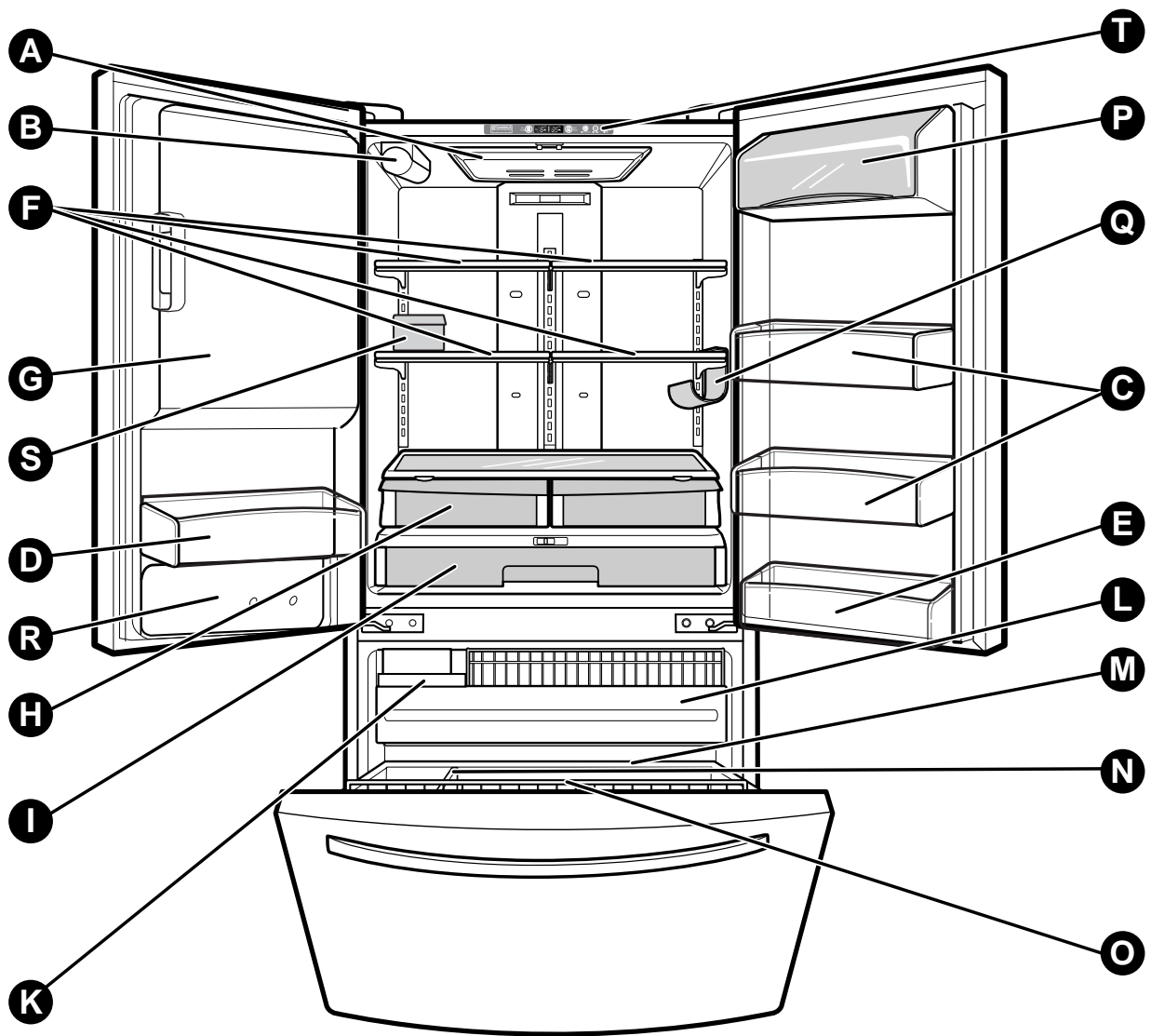

Use this page to become more familiar with the parts and features. Page references are included for your convenience.

NOTE: This guide covers several different models. The refrigerator you have purchased may have some or all of the items listed below. The locations of the features shown below may not match your model.

- | | |
|---|---|
| A Refrigerator Light | K Extra Ice Bin |
| B Filter (Inside) | L Pull out Drawer |
| C Modular Door Bins | M Durabase |
| D Fixed Door Bin | N Divider |
| E Fixed Door Bin | O Tilt-Out Door Basket
(795.7874 *Model Only) |
| F Refrigerator Shelves | P Dairy Bin |
| G Ice Room
(Ice Maker and Ice Bucket) | Q Bottle Holder |
| H Humidity Controlled Crisper | R Water Tank Cover |
| I Glide'N'Serve | S Egg Box |
| | T Cover Assembly, Display |

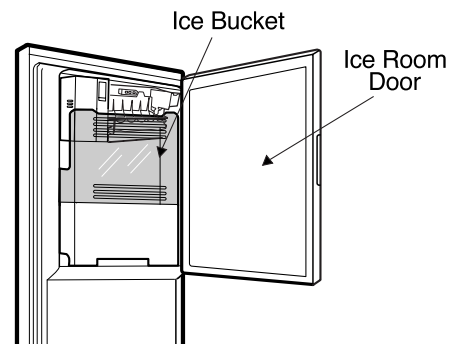

3. DISASSEMBLY

3-1 REMOVING AND REPLACING REFRIGERATOR DOORS

To remove the left refrigerator door:

Before attempting to remove the left door, locate the water connection at the back of the refrigerator. Pull the water tubing that comes out of the refrigerator by pushing in on the release ring while pulling on the water line as shown in the illustration below.

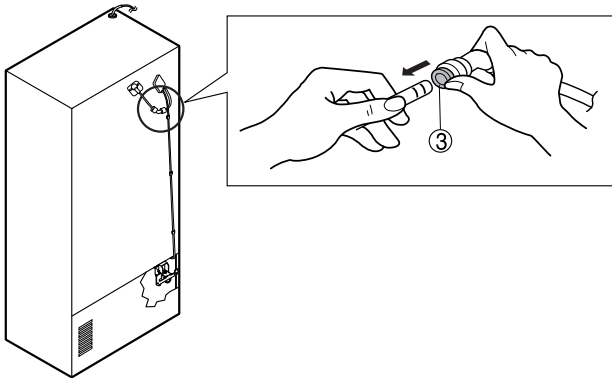

CAUTION : Before you begin, remove food and bins from the doors.

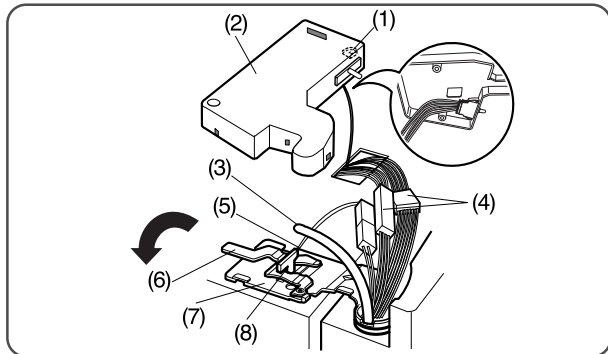

1. Open the door. Remove the top hinge cover screw (1).
2. Use a flat-head screwdriver to pry back the hooks (not shown) on the front underside of the cover (2). Lift up the cover.
3. Remove the cover. Pull out the tube (3).
4. Disconnect all the wire harnesses (4).
5. Remove the grounding screw (5).
6. Rotate hinge lever (6) counterclockwise and remove. Lift the top hinge (7) free of the hinge lever latch (8).

CAUTION : When lifting the hinge free of the latch, be careful that the door does not fall forward.

7. Lift the door from the middle hinge pin and remove the door.
8. Place the door, inside facing up, on a nonscratching surface.

To remove the right refrigerator door:

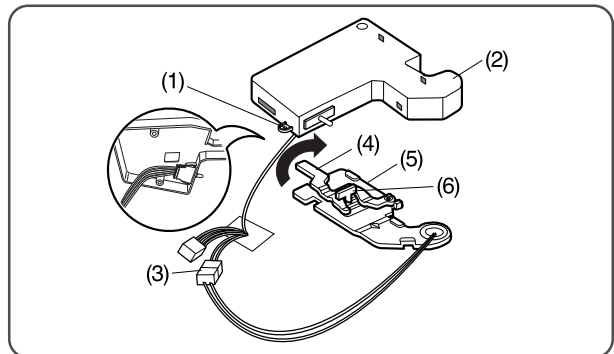

1. Open the door. Remove the top hinge cover screw (1). Lift up the cover (2).
2. Remove the cover.
3. Disconnect the wire harness (3).
4. Rotate the hinge lever (4) clockwise and remove. Lift the top hinge (5) free of the hinge lever latch (6).

CAUTION : When lifting the hinge free of the latch, be careful that the door does not fall forward.

WARNING

Electric Shock Hazard

- Disconnect electrical supply to the refrigerator before installing. Failure to do so could result in death or serious injury.
- Do not put hands or feet or other objects into the air vents, base grille, or bottom of the refrigerator. You may be injured or receive an electrical shock.
- Be careful when you work with the hinge, base grille, and stopper. You may be injured.

3-2 DOOR

● Door Gasket Removal

1. Remove door frame cover

Starting at top of cover and working down, snap cover out and away from door.

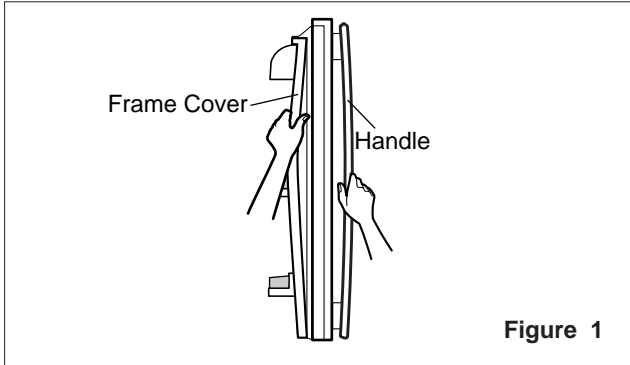

2. Remove gasket bracket clips

There are two clips on each door. Start bracket removal near one of the middle clips.

- 1) Pull gasket back to expose gasket bracket clip and door frame.
- 2) Insert a flat tip screwdriver into seam between gasket bracket and door frame and pry back until clips snap out.
- 3) Continue prying back along seam until all clips snap out.

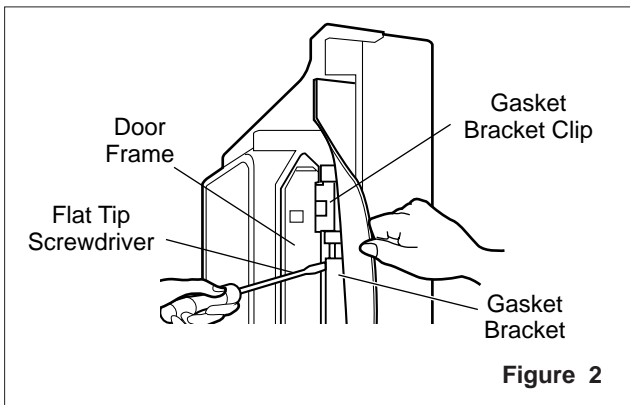

3. Remove gasket

Pull gasket free from gasket channel on the three remaining sides of door.

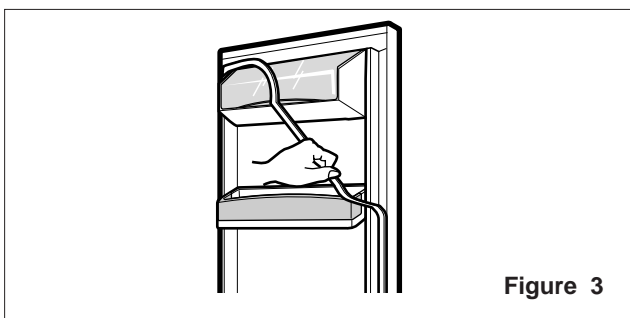

● Door Gasket Replacement

1. Insert gasket bracket clips

- 1) Insert gasket bracket edge beneath door frame edge.
- 2) Turn upper gasket bracket spring so that the spring ends are in the door channel.
- 3) Push in clip until you hear it snap securely into place.

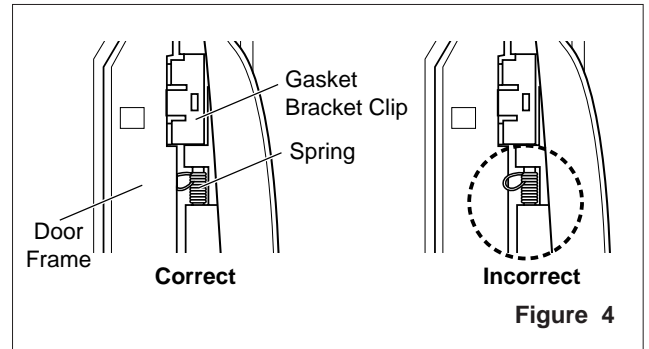

- 4) Push in remaining clip until you hear it snap securely into place.

Note: Make sure that no part of gasket bracket edge protrudes from beneath door frame edge.

2. Insert gasket into channel

- 1) Snap gasket assembly into the door bracket.

<Inserting the Gasket Assembly into the Bracket Door>

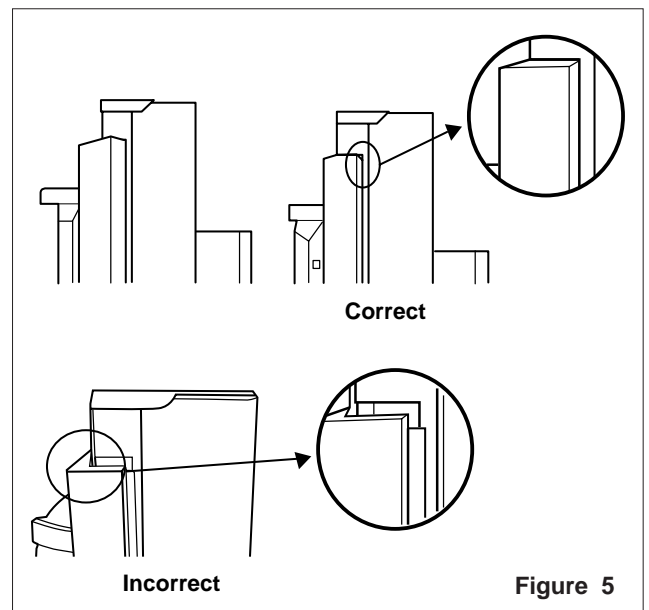

- 2) Press gasket into channels on the three remaining sides of door.

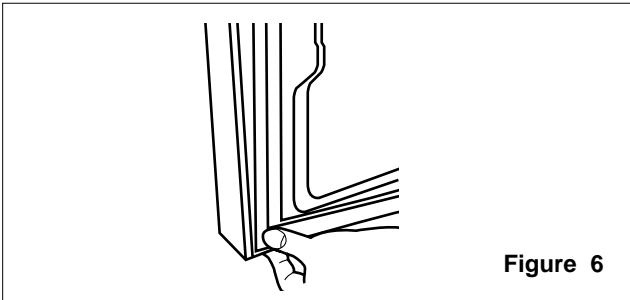

Figure 6

3. Replace door frame cover

Starting at top of cover and working down, snap cover back into door.

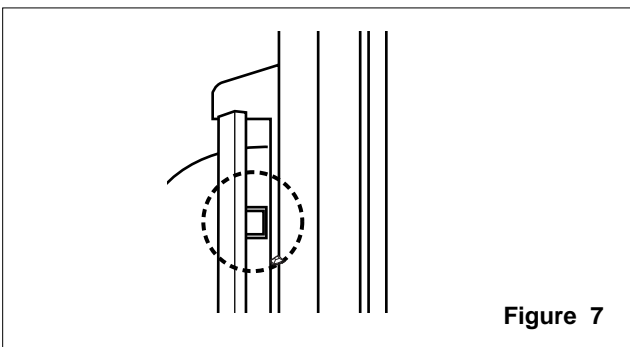

Figure 7

3-3 DOOR ALIGNMENT

If the space between your doors is uneven, follow the instructions below to align the doors:

1. With one hand, lift up the door you want to raise at middle hinge.
2. With other hand, use pliers to insert snap ring as shown.
3. Insert additional snap rings until the doors are aligned.
(Three snap rings are provided with unit.)

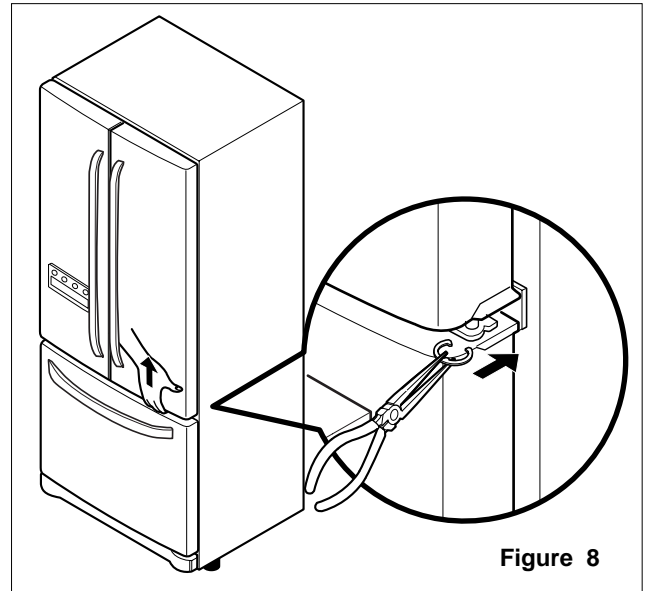

Figure 8

3-4 FAN AND FAN MOTOR(EVAPORATOR)

1. Remove the freezer shelf. (If your refrigerator has an icemaker, remove the icemaker first)
2. Remove the plastic guide for slides on left side by unscrewing phillips head screws.
3. Remove the grille by removing one screw and pulling the grille forward.
4. Remove the Fan Motor assembly by loosening 2 screws and disassembling the shroud.
5. Pull out the fan and separate the Fan Motor and Bracket.

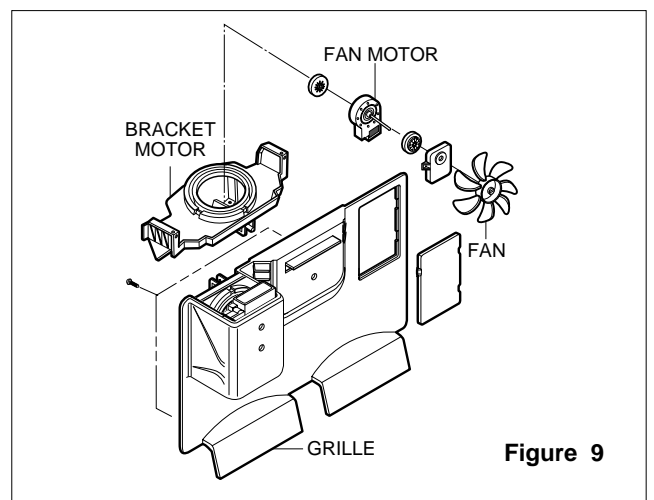

Figure 9

* Ice Fan Scroll Assembly Replacement

- 1) Remove the plastic guide for slides on left side by unscrewing phillips head screws.
- 2) Pull the grille forward as shown in the second picture.
- 3) Disconnect wire harness of the grille
- 4) Remove the scroll assembly by loosening 2 screws



(1)



(2)



(3)



(4)

3-5 DEFROST CONTROL ASSEMBLY

Defrost Control assembly consists of Defrost Sensor and FUSE-M.

The Defrost Sensor works to defrost automatically. It is attached to the metal side of the Evaporator and senses its temperature. At 72°C, it turns the Defrost Heater off. Fuse-M is a safety device for preventing over-heating of the Heater when defrosting.

1. Pull out the grille assembly. (Figure 10)
2. Separate the connector with the Defrost Control assembly and replace the Defrost Control assembly after cutting the Tie Wrap. (Figure 11)

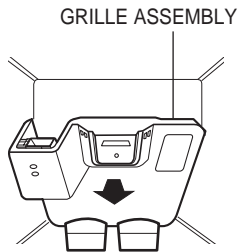

Figure 10

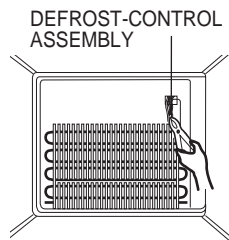

Figure 11

3-6 LAMP

Unplug Refrigerator, or disconnect power at the circuit breaker.

If necessary, remove top shelf or shelves.

3-6-1 Refrigerator Compartment Lamp

- 1) Release 2 screws.
- 2) Hold both ends with your both hands and pull it downward to remove it.
- 3) Use a flat tool as shown below to remove the cover lamp.



Figure 12

- 4) As shown below, use a flat tool to remove the cover lamp.



Figure 13



Cover, Lamp



LED, Assembly

Case Lamp

Figure 14

3-6-2 Freezer Compartment Lamp

1. Unplug refrigerator power cord form outlet.
2. Remove screw with direver.
3. Grasp the cover Lamp,pull the cover downward.



Figure 15

3-7 MULTI DUCT

1. Remove the upper and lower Caps by using a flat screwdriver, and remove 2 screws. (Figure 17)
2. Disconnect the lead wire on the bottom position.

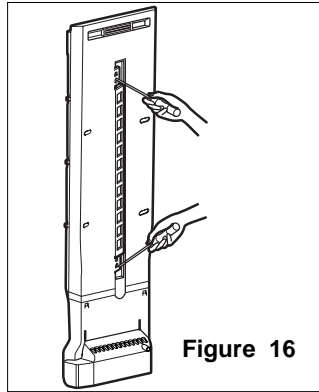

3-8 MAIN PWB

- 1) Loosen the 4 screws on the PWB cover.



- 2) Remove the PWB cover



- 3) Disconnect wire harness and replace the main PWB in the reverse order of removal.



3-9 SERVICEABILITY REVIEW FOR HIDDEN DISPENSER



1) With the unit unplugged from the power source, you can manually open the dispenser cover using a small flat blade screwdriver. The cover will remain opened during the repair.



2) Unscrew left and right side (cross driver)



3) All harness have to be removed before separation of cover



4) Unscrew 2 points and then remove connector-cover



5) Separate tube (5/16") from connector (clip have to be removed first)

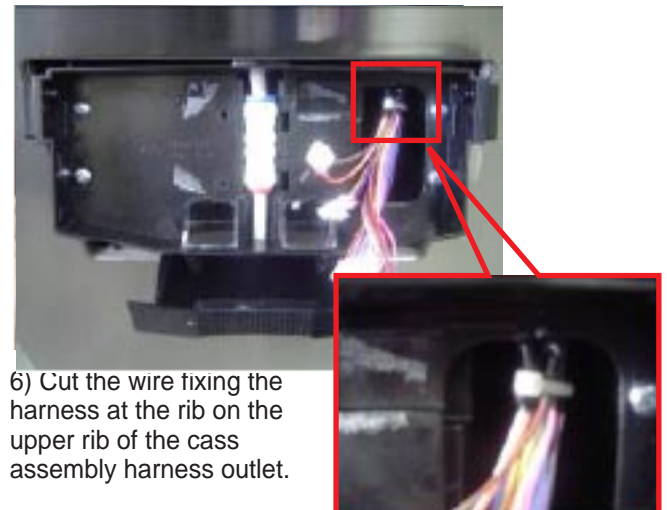

6) Cut the wire fixing the harness at the rib on the upper rib of the cassette assembly harness outlet.



7) Unscrew 2 points to separate tray-cover



8) Separate the Tray-cover after pull them toward your body.



9) Pull down funnel .

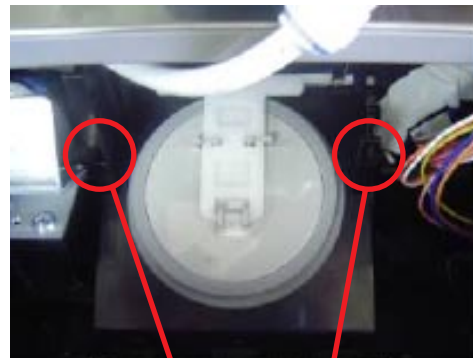

10) Fix the left rib and the right rib at the marked spots correctly.



11) Before separation of Bracket, connecting rod have to be at back side position.



12) Separate the Switch connection harness.



13) Unscrew 3 points at the Duct Assembly.



14) Pull down and rotate toward your body duct assembly for separation.



15) All harness have to be separated.



16) Unscrew the 1 screw at the gear (left and right)



17) Separate gear (left and right)



18) Unscrew 2 point with short length driver



19) Pull motor box inside and then separate harness.



20) Sensor box can be disassembled after removal of 3 screws in same case of motor box.

3-10 ICE CORNER DOOR REPLACEMENT

- 1) Loosen the front screw as shown in the picture.
- 2) Lift up the hinge with one hand.
- 3) Pull out the Ice Corner Door with the other hand.



- 3) It separates a ground connection screw.



3-11 ICEMAKER ASSEMBLY

- 1) Loosen two screws as shown in the first picture.

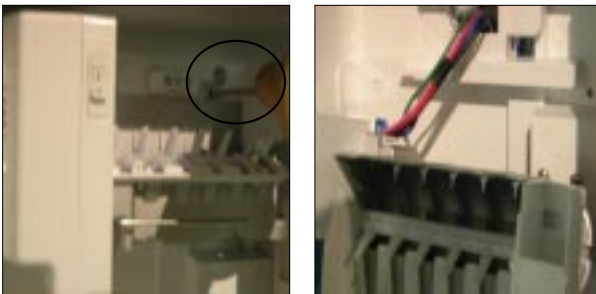

- 2) Disconnect the wire harness & ground screw replace the icemaker assembly in the reverse order of removal.



3-12 AUGER MOTOR COVER

1) After removing the icemaker remove the (5) stainless screws holding the auger motor cover, shown in the pictures below.

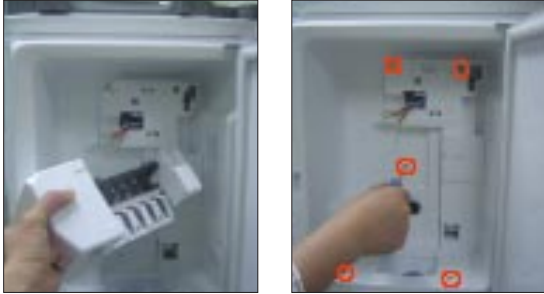

2) Grip the bottom of motor cover assembly and pull out it.



3) Disconnect wire harness of motor cover assembly. There is a auger motor on the back, as shown in the picture.

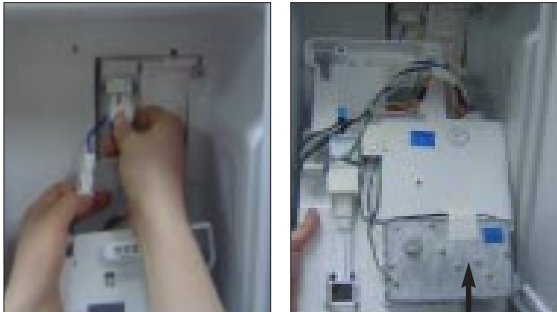

Auger Motor

3-13 HOW TO REMOVE THE SUB PCB

1) Lift up the Fixed Door Bin to remove.



2) Unscrew one screw fixing the Cover Front and the Sub PCB.



3) Pull the Cover Front to remove.



4) Insert the (-) screw driver into the center hole of the upper Sub PCB, and remove the Sub PCB.



5) Remove two housings connecting to the Sub PCB.



6) Pull the Sub PCB to remove.



3-14 HOW TO REMOVE A DOOR ICE BIN

1) Grip the handles, as shown in the picture.

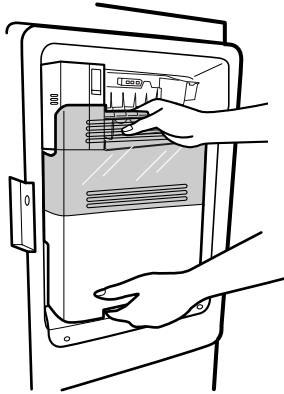

2) Lift the lower part slightly.

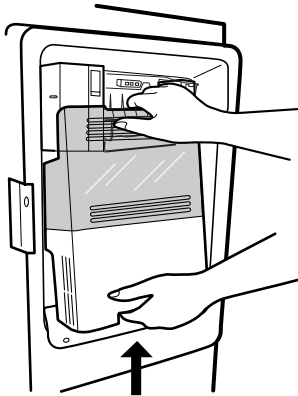

3) Take the Ice Bin out slowly.

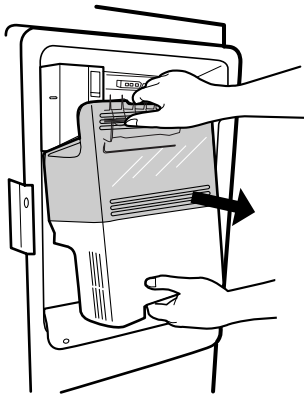

3-15 HOW TO INSERT A DOOR ICE BIN

1) Insert the Ice Bin, slightly tilting it to avoid touching the Icemaker. (especially, ice maker lever)

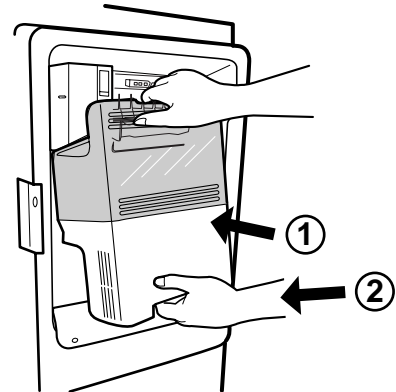

※ Insert the ice bucket carefully avoid contacting the automatic shut off arm.

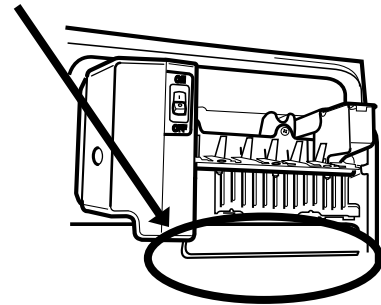

3-16 HOW TO REMOVE AND REINSTALL THE PULLOUT DRAWER

3-16-1 Follow Steps to Remove

Step 1) Open the freezer door.



Step 2) Remove the lower basket.



Step 3) Remove the two screws from the guide rails (one from each side).

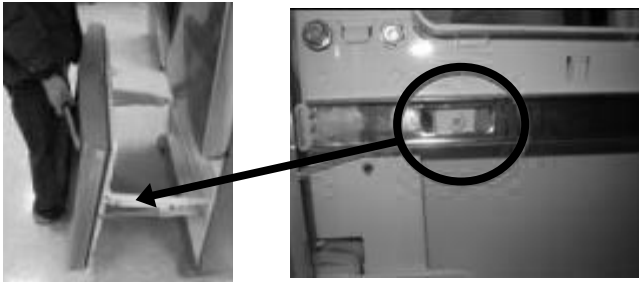

Step 4) Lift the freezer door up to unhook it from the rail support and remove. Pull both rails to full extension.



Step 5) First: Remove the gear from the left side first by releasing the tab behind the gear, place a screwdriver between the gear and the tab and pull up on the gear.

Second: Remove the center rail.

Third: Remove the gear from the right side by following the same steps for the left side.

NOTE: THIS TAB MUST BE PUSHED IN TO RELEASE THE GEAR.

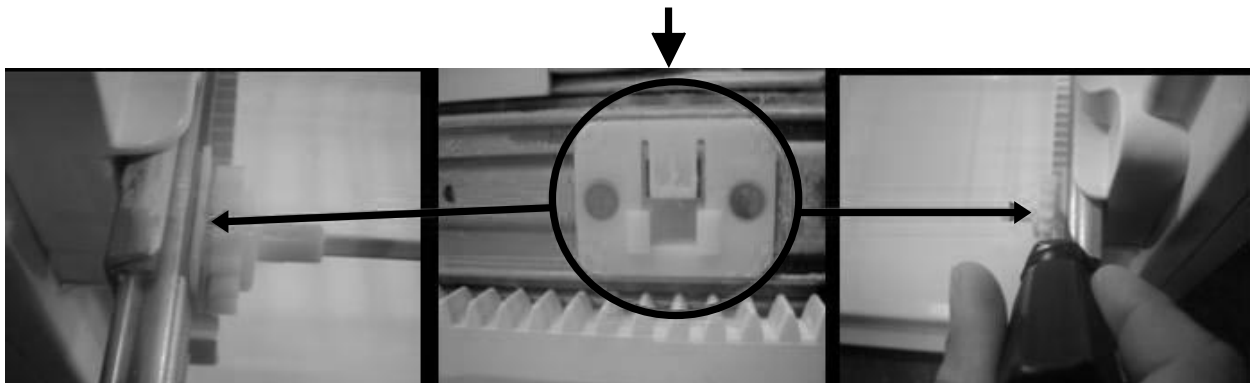

3-16-2 Follow Steps to Reinstall

Step 1) Reinstall the right side gear into the clip.



Step 2) Insert the rail into the right side gear. Gears do **not** need to be perpendicular to each other.



Step 3) Insert the rail into the left side gear, and insert the gear into the clip.



Step 4) The rail system will align itself by pushing the rails all the way into the freezer section. Pull the rails back out to full extension.



Step 5) Reinstall the freezer door by inserting the rail tabs into the guide rail.



Step 6) Reinstall the two screws into the guide rails (one from each side).

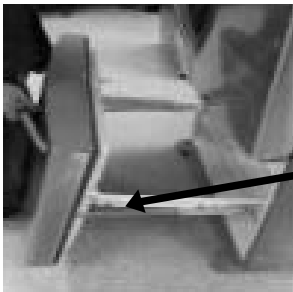

Step 7) Reinstall the lower basket, and close the freezer door.



3-17. WATER VALVE DISASSEMBLY METHOD

1) Turn off the water. Then separate the water line from the valve.

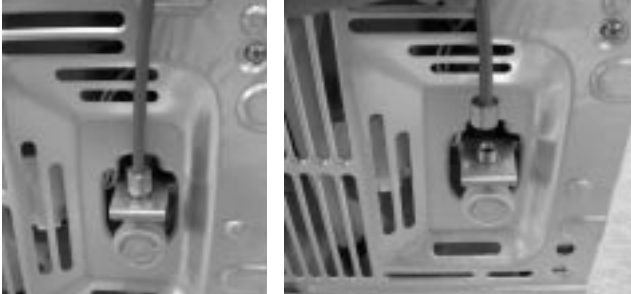

2) Separate the Mechanical Cover and Valve Screw.



3) Separate the housing and pull out the valve.

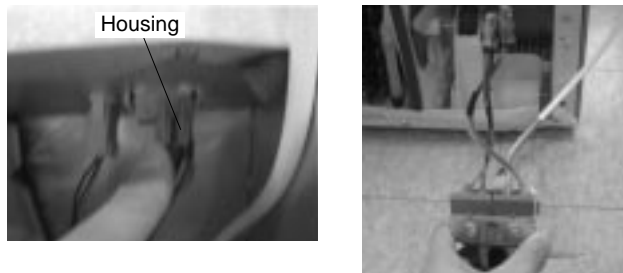

4) Lay a dry towel on the floor and get ready to spill water from the water filter. Pull out the Cilp. Then press te collet to separate the tube from the connector and pour out the water until emptied.

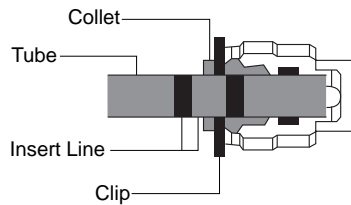

3-18. FAN AND FAN MOTOR DISASSEMBLY METHOD

1) Using a short screwdriver, loosen one SCREW in DRAIN PIPE ASSEMBLY and one connected to the MOTOR COVER.

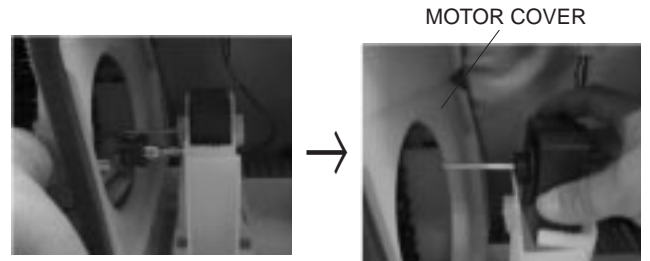

2) Pull and separate the FAN ASSEMBLY and MOTOR turning counterclockwise based on the MOTOR SHAFT.

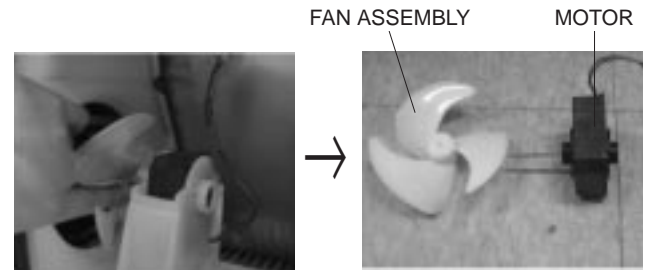

The assembly is in the reverse order of the disassembly and take special care for the following details.

1. Be careful not to bend the tube during assembly.
2. Press the WATER DISPENSER button until water pours out and check for leakage in the CONNECTOR TUBE (It differs by the water pressure but usually takes about 2 minutes until water pours out.)

3-19 PULL OUT DRAWER

To separate the drawer, push the front left and right hooks in ① direction to pull up and remove.
Then gently lift the gear part of rear left and right side of the drawer and pull it out in ③ direction.

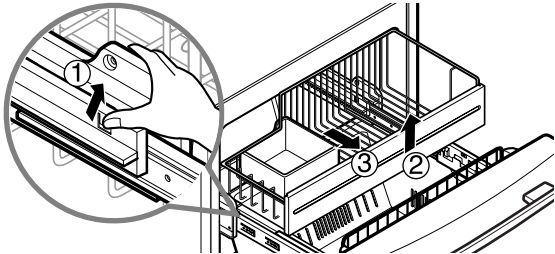

To install, reposition the gear part of rear left and right side of the drawer after pulling out both rails as much as possible, and gently push down both left and right side while checking the hook on the front part.

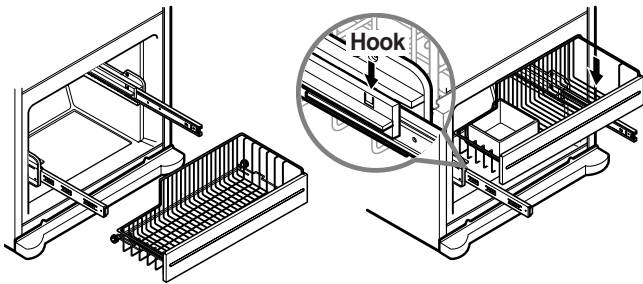

4. ADJUSTMENT

4-1 COMPRESSOR

4-1-1 Role

The compressor intakes low temperature and low pressure gas from the evaporator of the refrigerator and compresses this gas to high-temperature and high-pressure gas. It then delivers the gas to the condenser.

4-1-2 Composition

The compressor includes overload protection. The PTC starter and OLP (overload protector) are attached to the outside of the compressor. Since the compressor is manufactured to tolerances of 1 micron and is hermetically sealed in a dust and moisture-free environment, use extreme caution when performing repairs.

4-1-3 Note for Usage

- (1) Be careful not to allow over-voltage and over-current.
- (2) If compressor is dropped or handled carelessly, poor operation and noise may result.
- (3) Use proper electric components appropriate to the Particular Compressor in your product.
- (4) Keep Compressor dry.
If the Compressor gets wet (in the rain or a damp environment) and rust forms in the pin of the Hermetic Terminal, poor operation and contact may result.
- (5) When replacing the Compressor, be careful that dust, humidity, and soldering flux don't contaminate the inside of the compressor. Dust, humidity, and solder flux contaminate the cylinder and may cause noise, improper operation or even cause it to lock up.

4-2 PTC-STARTER

4-2-1 Composition of PTC-Starter

- (1) PTC (Positive Temperature Coefficient) is a no-contact semiconductor starting device which uses ceramic material consisting of BaTiO₃.
- (2) The higher the temperature is, the higher the resistance value. These features are used as a starting device for the Motor.

4-2-2 Role of PTC-Starter

- (1) The PTC is attached to the Sealed Compressor and is used for starting the Compressor Motor.
- (2) The compressor is a single-phase induction motor. The starting operation, the PTC allows current flow to both the start winding and main winding.

4-2-3 PTC-Applied Circuit Diagram

● Starting Method for the Motor

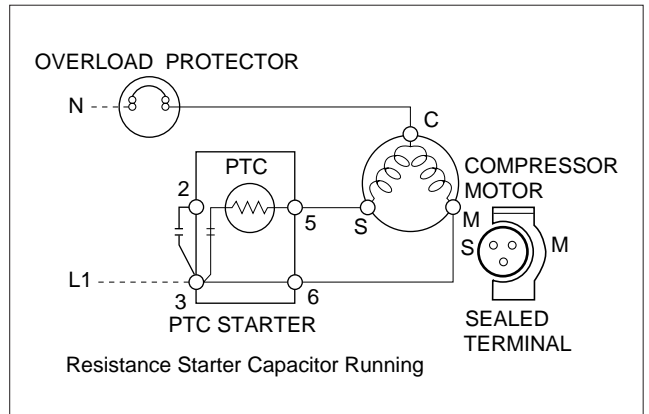

4-2-4 Motor Restarting and PTC Cooling

- (1) It requires approximately 5 minutes for the pressure to equalize before the compressor can restart.
- (2) The PTC device generates heat during operation. Therefore, it must be allowed to cool before the compressor can restart.

4-2-5 Relation of PTC-Starter and OLP

- (1) If the compressor attempts to restart before the PTC device is cooled, the PTC device will allow current to flow only to the main winding.
- (2) The OLP will open because of the over current condition. This same process will continue (3 to 5 times) when the compressor attempts to restart until the PTC device has cooled. The correct OLP must be properly attached to prevent damage to the compressor.
Parts may appear physically identical but could have different electrical ratings. Replace parts by part number and model number. Use only approved substitute parts.

4-2-6 Note for Using the PTC-Starter

- (1) Be careful not to allow over-voltage and over-current.
- (2) Do not drop or handle carelessly.
- (3) Keep away from any liquid.
If liquid such as oil or water enters the PTC, PTC materials may fail due to breakdown of their insulating capabilities.
- (4) If the exterior of the PTC is damaged, the resistance value may be altered. This can cause damage to the compressor and result in a no-start or hard-to-start condition.
- (5) Always use the PTC designed for the compressor and make sure it is properly attached to the compressor. Parts may appear physically identical but could have different electrical ratings. Replace parts by part number and model number. Use only approved substitute parts.

4-3 OLP (OVERLOAD PROTECTOR)

4-5-1 Definition of OLP

- (1) OLP (OVERLOAD PROTECTOR) is attached to the Compressor and protects the Motor by opening the circuit to the Motor if the temperature rises and activating the bimetal spring in the OLP.
- (2) When high current flows to the Compressor motor, the Bimetal works by heating the heater inside the OLP, and the OLP protects the Motor by cutting off the current flowing to the Compressor Motor.

4-5-2 Role of the OLP

- (1) The OLP is attached to the Sealed Compressor used for the Refrigerator. It prevents the Motor Coil from being started in the Compressor.
- (2) For normal operation of the OLP, do not turn the Adjust Screw of the OLP in any way.

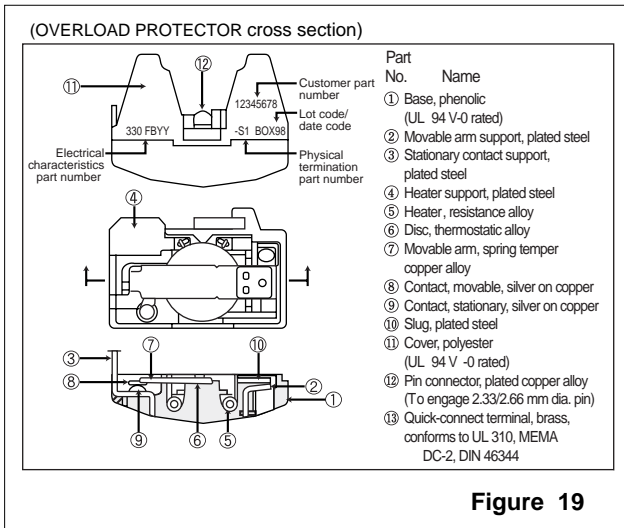

4-4 TO REMOVE THE COVER PTC

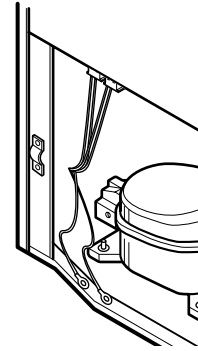

- (1) Remove the Cover Back M/C.
- (2) Disconnect two housing upper side of comp connected in.
- (3) Loosen two screws on comp base.

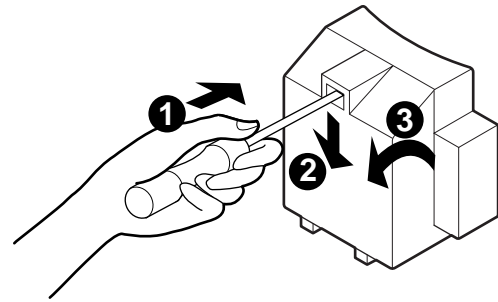

- (4) Use a L-shaped flap tool to pry off the cover.
- (5) Assembly in reverse order of disassembly.

5. CIRCUIT DIAGRAM

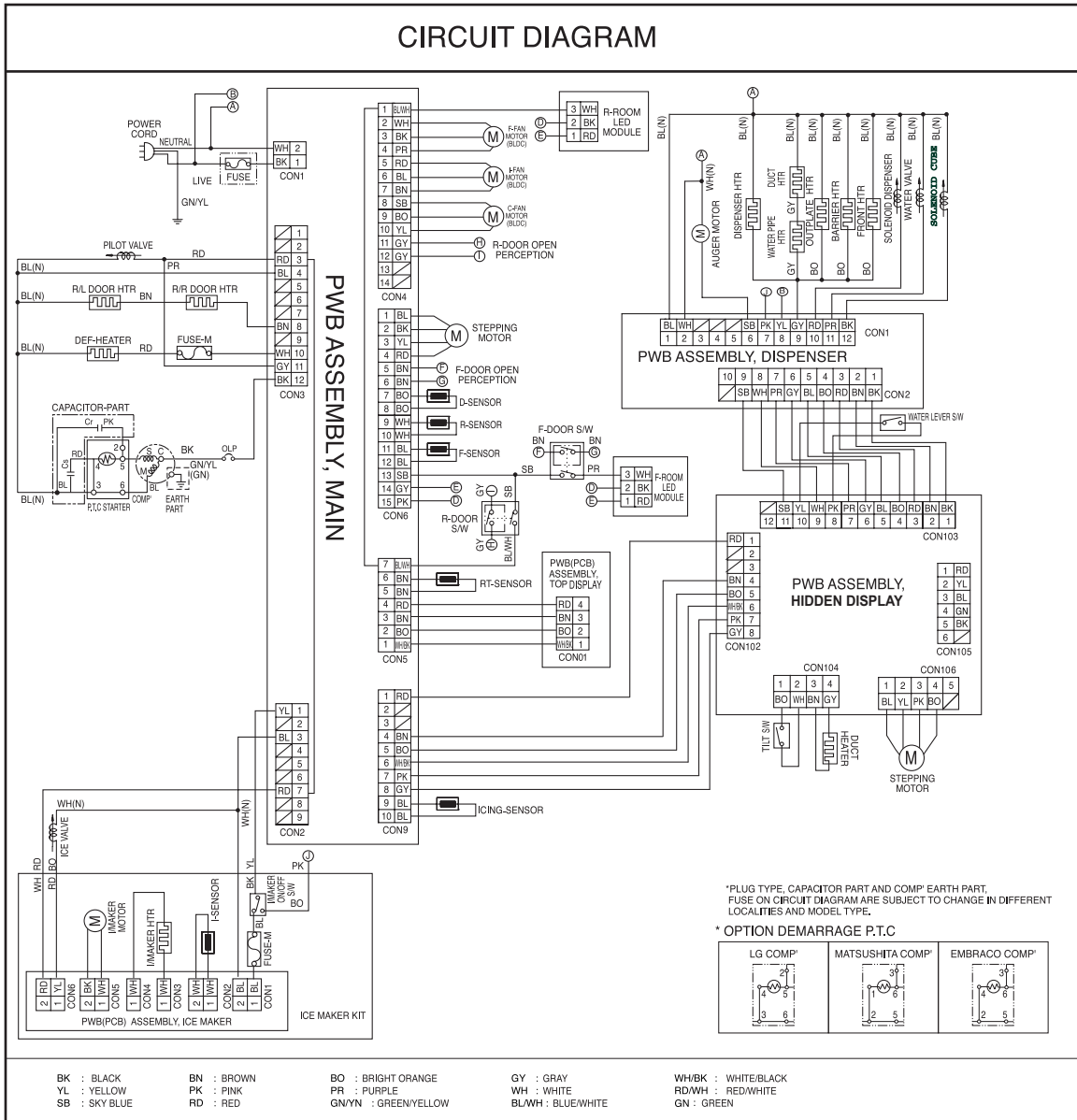

6. TROUBLESHOOTING

6-1 COMPRESSOR AND ELECTRIC COMPONENTS

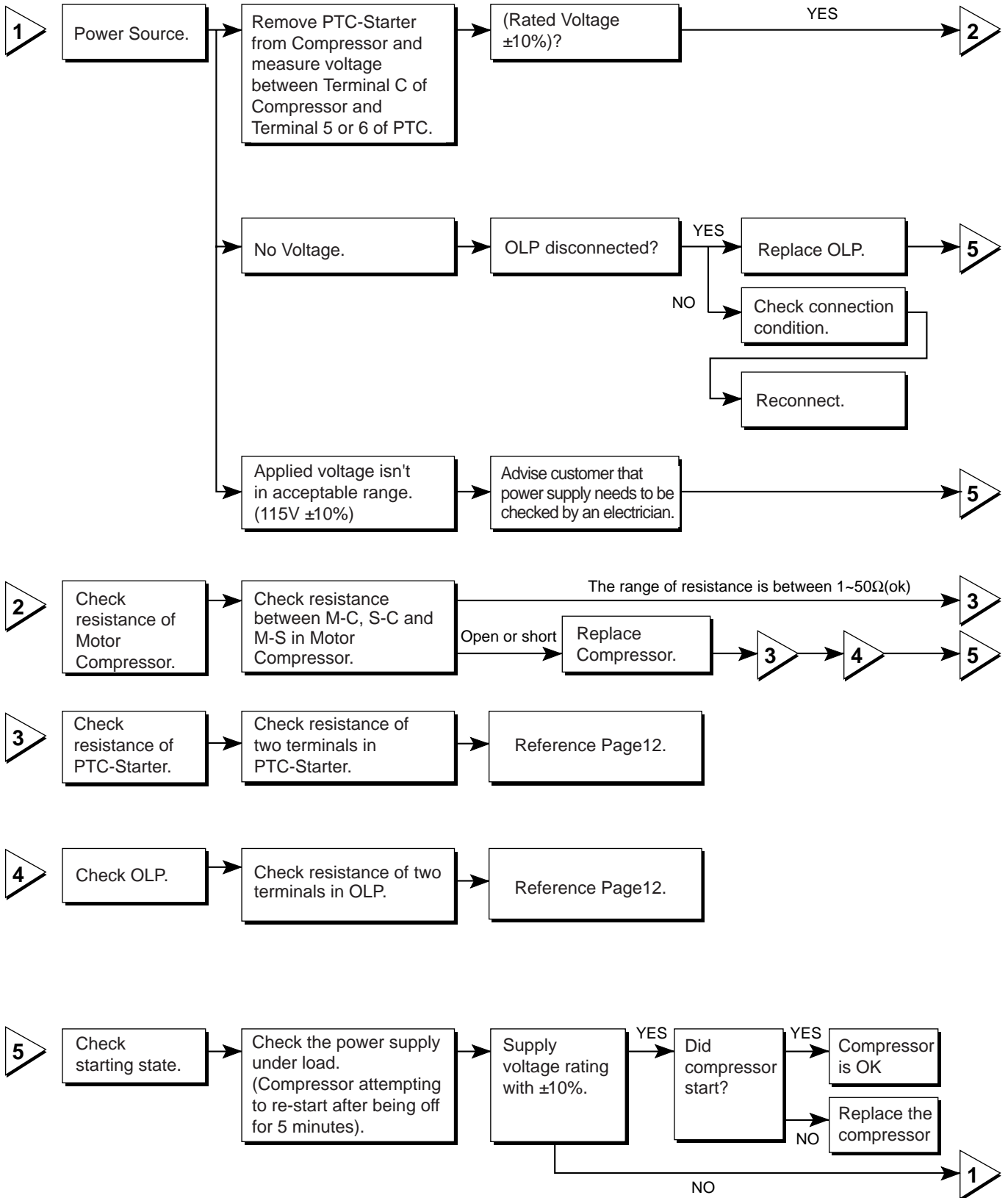

6-2 OTHER ELECTRICAL COMPONENTS

▼ Not cooling at all

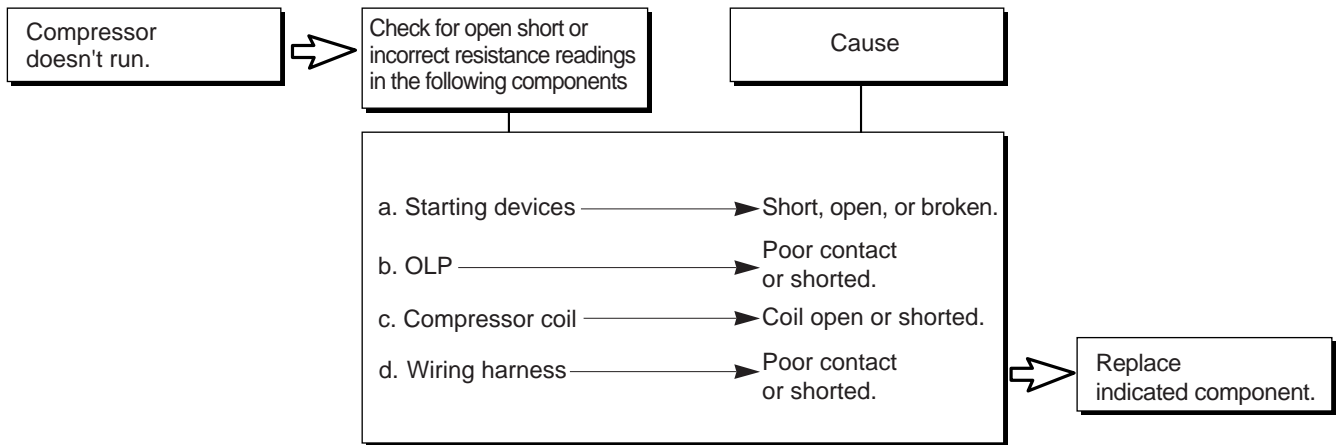

▼ Poor cooling performance

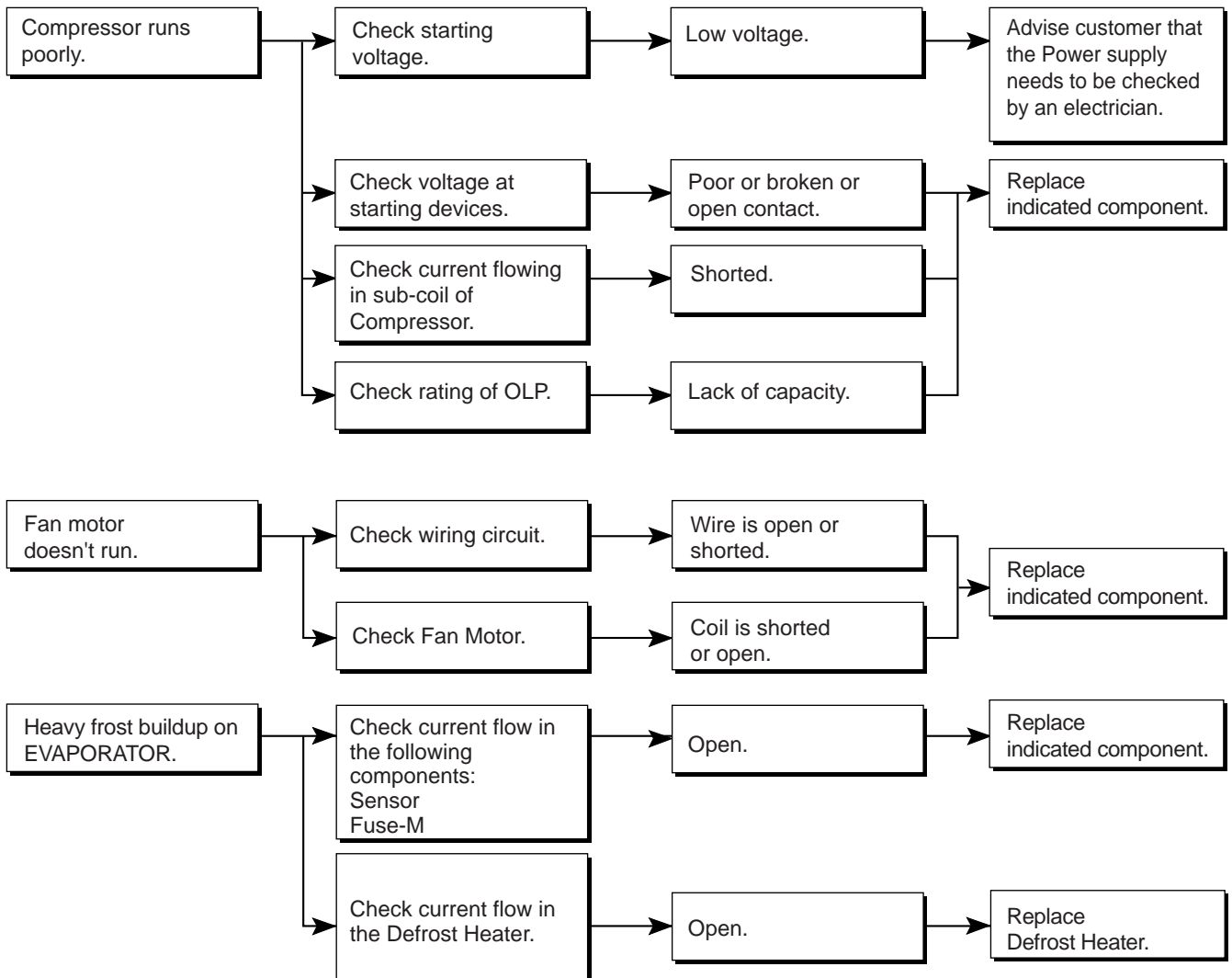

6-3 SERVICE DIAGNOSIS CHART

COMPLAINT	POINTS TO BE CHECKED	REMEDY
No Cooling.	<ul style="list-style-type: none"> • Is the power cord unplugged from the outlet? • Check if the power switch is set to OFF. • Check if the fuse of the power switch is shorted. • Measure the voltage of the power outlet. 	<ul style="list-style-type: none"> • Plug into the outlet. • Set the switch to ON. • Replace the fuse. • If the voltage is low, correct the wiring.
Cools poorly.	<ul style="list-style-type: none"> • Check if the unit is placed too close to the wall. • Check if the unit is placed too close to the stove, gas cooker, or in direct sunlight. • Is the ambient temperature too high or the room door closed? • Check if food put in the refrigerator is hot. • Did you open the door of the unit too often or check if the door is sealed properly? • Check if the Control is set to Warm position. 	<ul style="list-style-type: none"> • Place the unit about 4 inches (10 cm) from the wall. • Place the unit away from these heat sources. • Lower the ambient temperature. • Put in foods after they have cooled down. • Don't open the door too often and close it firmly. • Set the control to Recommended position.
Food in the Refrigerator is frozen.	<ul style="list-style-type: none"> • Is food placed in the cooling air outlet? • Check if the control is set to colder position. • Is the ambient temperature below 41°F(5°C)? 	<ul style="list-style-type: none"> • Place foods in the high-temperature section. (front part) • Set the control to Recommended position. • Set the control to Warm position.
Condensation or ice forms inside the unit.	<ul style="list-style-type: none"> • Is liquid food sealed? • Check if food put in the refrigerator is hot. • Did you open the door of the unit too often or check if the door is sealed properly? 	<ul style="list-style-type: none"> • Seal liquid foods with wrap. • Put in foods after they have cooled down. • Don't open the door too often and close it firmly.
Condensation forms in the Exterior Case.	<ul style="list-style-type: none"> • Check if the ambient temperature and humidity of the surrounding air are high. • Is there a gap in the door gasket? 	<ul style="list-style-type: none"> • Wipe moisture with a dry cloth. It will disappear in low temperature and humidity. • Fill up the gap.
There is abnormal noise.	<ul style="list-style-type: none"> • Is the unit positioned in a firm and even place? • Are any unnecessary objects placed in the back side of the unit? • Check if the Drip Tray is not firmly fixed. • Check if the cover of the compressor enclosure in the lower front side is taken out. 	<ul style="list-style-type: none"> • Adjust the Leveling Screw, and position the refrigerator in a firm place. • Remove the objects. • Fix the Drip Tray firmly in the original position. • Place the cover in its original position.
Door does not close well.	<ul style="list-style-type: none"> • Check if the door gasket is dirty with an item like juice. • Is the refrigerator level? • Is there too much food in the refrigerator? 	<ul style="list-style-type: none"> • Clean the door gasket. • Position in a firm place and level the Leveling Screw. • Make sure food stored in shelves does not prevent the door from closing.
Ice and foods smell unpleasant.	<ul style="list-style-type: none"> • Check if the inside of the unit is dirty. • Are foods with a strong odor unwrapped? • The unit smells of plastic. 	<ul style="list-style-type: none"> • Clean the inside of the unit. • Wrap foods that have a strong odor. • New products smell of plastic, but this will go away after 1-2 weeks.

● Other possible problems:

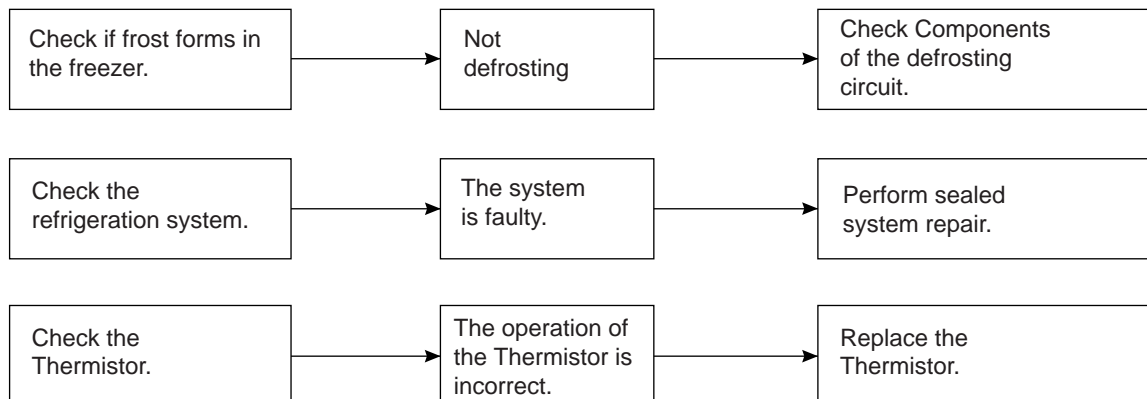

6-4 REFRIGERATION CYCLE

▼ Troubleshooting Chart

CAUSE		STATE OF THE UNIT	STATE OF THE EVAPORATOR	TEMPERATURE OF THE COMPRESSOR	REMARKS
LEAKAGE	PARTIAL LEAKAGE	Freezer compartment and Refrigerator don't cool normally.	Low flowing sound of Refrigerant is heard and frost forms in inlet only.	A little higher than ambient temperature.	<ul style="list-style-type: none"> Refrigerant level is low due to a leak. Normal cooling is possible by restoring the normal amount of refrigerant and repairing the leak.
	COMPLETE LEAKAGE	Freezer compartment and Refrigerator don't cool normally.	Flowing sound of refrigerant is not heard and frost isn't formed.	Equal to ambient temperature.	<ul style="list-style-type: none"> No discharging of Refrigerant. Normal cooling is possible by restoring the normal amount of refrigerant and repairing the leak.
CLOGGED BY DUST	PARTIAL CLOG	Freezer compartment and Refrigerator don't cool normally.	Flowing sound of refrigerant is heard and frost forms in inlet only.	A little higher than ambient temperature.	<ul style="list-style-type: none"> Normal discharging of the refrigerant. The capillary tube is faulty.
	WHOLE CLOG	Freezer compartment and Refrigerator don't cool.	Flowing sound of refrigerant is not heard and frost isn't formed.	Equal to ambient temperature.	<ul style="list-style-type: none"> Normal discharging of the Refrigerant.
MOISTURE CLOG		Cooling operation stops periodically.	Flowing sound of refrigerant is not heard and frost melts.	Lower than ambient temperature.	<ul style="list-style-type: none"> Cooling operation restarts when heating the inlet of the capillary tube.
DEFECTIVE COMPRESSION	COMP-RESSION	Freezer and Refrigerator don't cool.	Low flowing sound of refrigerant is heard and frost forms in inlet only.	A little higher than ambient temperature.	<ul style="list-style-type: none"> Low pressure at high side of compressor due to low refrigerant level.
	NO COMP-RESSION	No compressing operation.	Flowing sound of refrigerant is not heard and there is no frost.	Equal to ambient temperature.	<ul style="list-style-type: none"> No pressure in the high pressure part of the compressor.

6-4-1 SEALED SYSTEM DIAGNOSIS

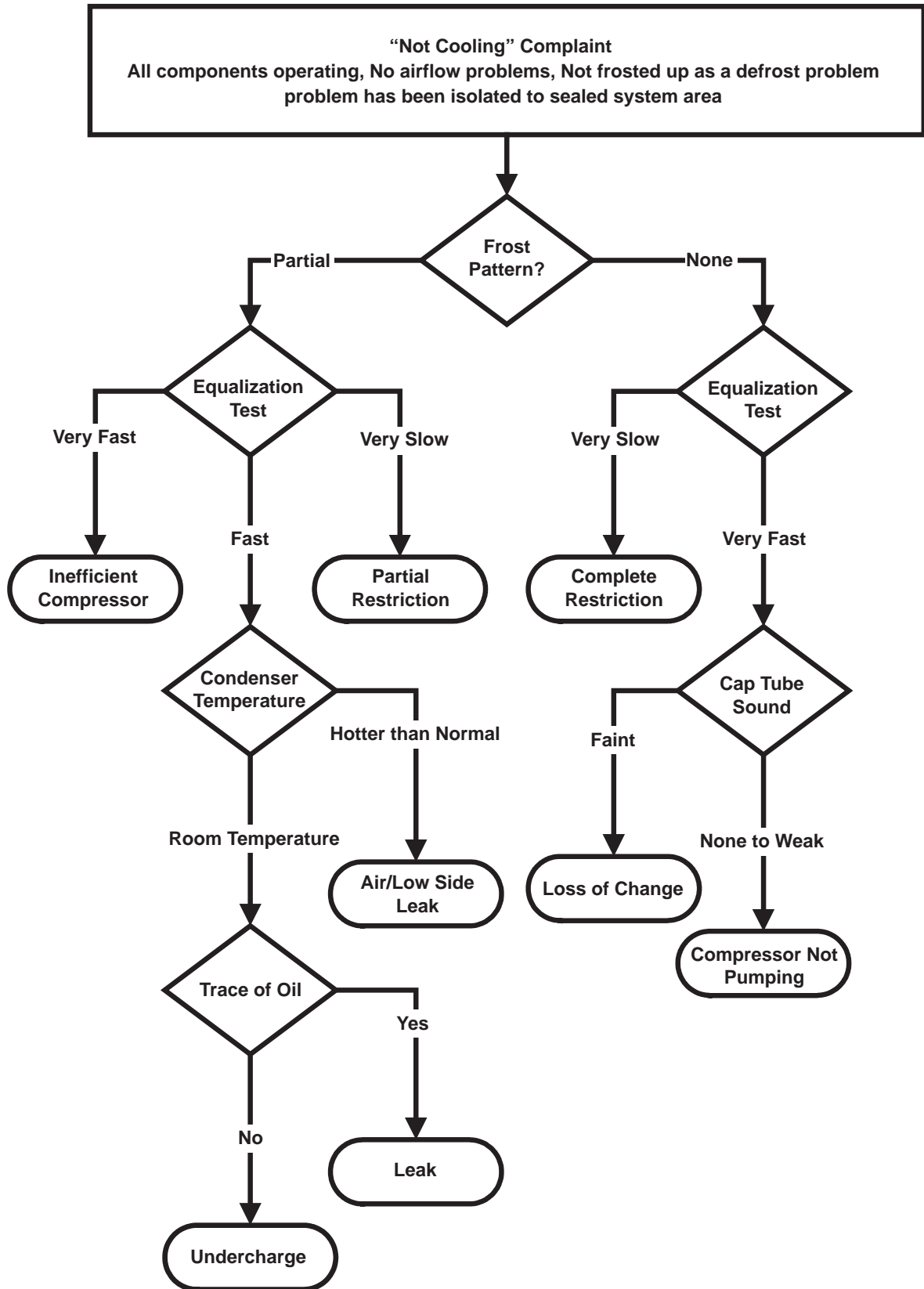

(The equalization test is trying to restart a compressor using a start kit after it has been operating.)

6-5 OPERATION PRINCIPLE

6-5-1 Operation Principle of IceMaker

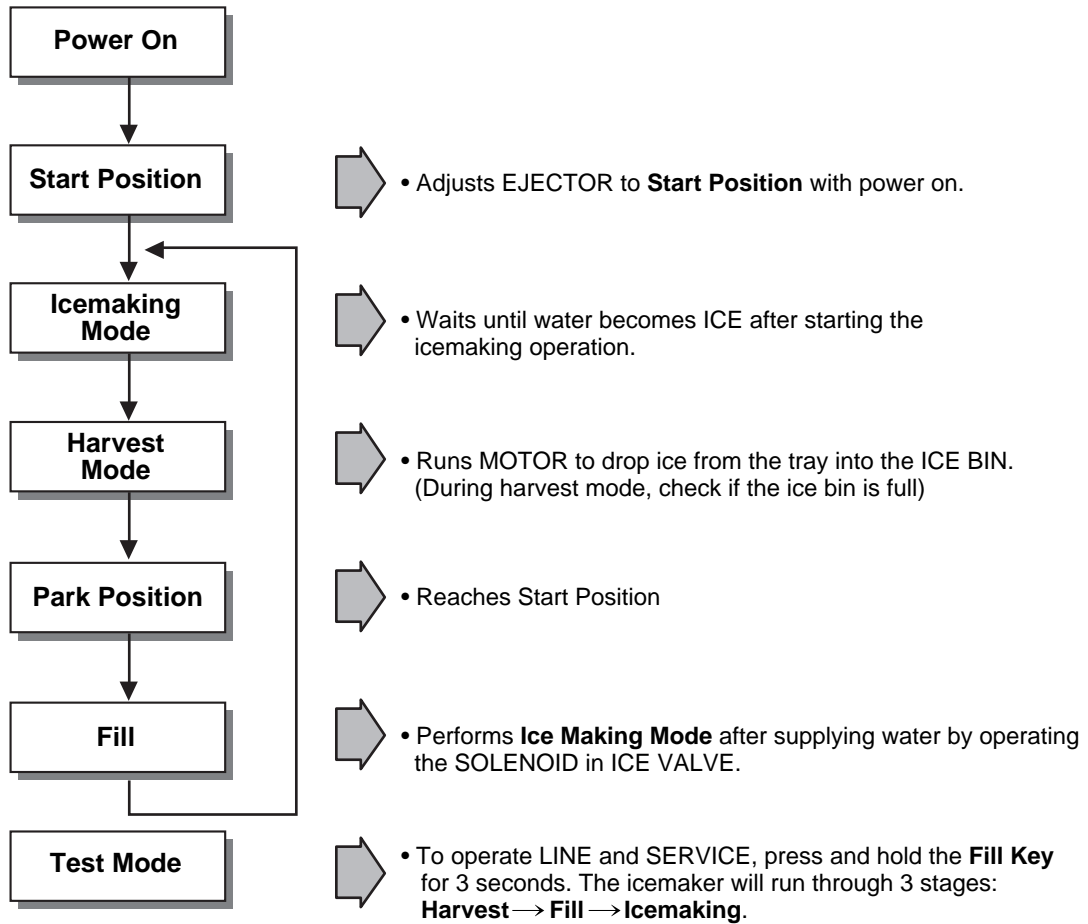

1. Turning the Icemaker stop switch off (O) stops the ice making function.
2. Setting the Icemaker switch to OFF and then turning it back on will reset the icemaker control.

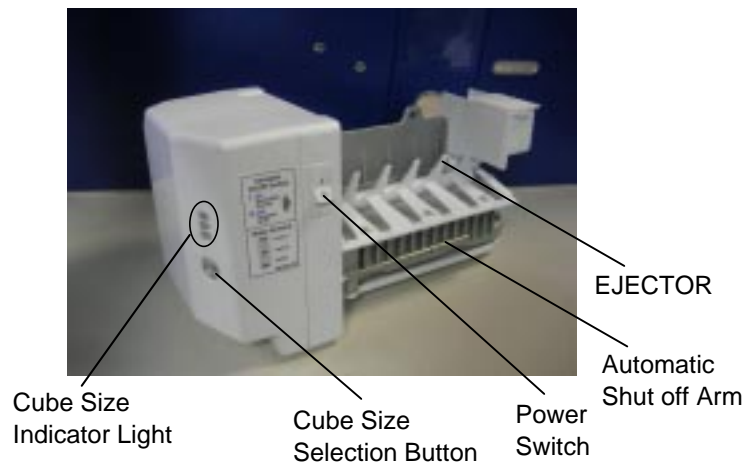

6-6 ICE MAKER FUNCTIONS

6-6-1. Icemaking Mode

1. Icemaking refers to the freezing of supplied water in the ice tray. Complete freezing is assured by measuring the temperature of the Tray with Icemaking SENSOR.
2. Icemaking starts after completion of the water fill operation.
3. The Ice Making function is completed when the sensor reaches 19°F (-7°C), 55 minutes after starting.

NOTE : After Icemaker Power is ON, the Icemaker heater will be on for test for 6 sec.



6-6-2. Harvest Mode

1. Harvest (Ice removing) refers to the operation of dropping ices into the ice bin from the tray when icemaking has completed.
 2. Harvest mode:
 - (1) The Heater is ON for 30 seconds, then the motor starts.
 - (2) The feeler arm senses the quantity of ice in the ice storage bin while rotating with the EJECTOR.
 - A. Ice storage bin is full : The EJECTOR stops (heater off).
 - B. Ice storage bin is not full : The EJECTOR rotates twice to open for ice.
- ※ If the EJECTOR does not rotate once within 5 minutes in B mode, separate heater control mode starts operating to prevent the EJECTOR from being constrained. (It is recommended that the user open for ice to return to normal mode.)

6-6-3. Fill/Park Position

1. Once a normal harvest mode has been completed, the water solenoid will be activated.
2. The amount of water is adjusted by pressing the Fill Key repeatedly. This changes the time allowed for fill as illustrated in the table below.





Water supply amount TABLE

STAGE	TIME TO SUPPLY	INDICATIONS	REMARKS
1	5 sec.		The water amount will vary depending on the water control Switch setting, as well as the water pressure of the connected water line.
2	5.5 sec. (FIRST STAGE)		
3	6 sec.		

6-6-4 Function TEST

1. This is a forced operation for TEST, Service, cleaning, etc. It is operated by pressing and holding the Fill Key for 3 seconds.
2. The test works only in the Icemaking Mode. It cannot be entered from the Harvest or Fill mode.
3. **Caution!** If the test is performed before water in the icemaker is frozen, the ejector will pass through the water. When the Fill mode begins (Stage 4), unless the water supply has been shut off, added water will overflow into the ice bin. If the control doesn't operate normally in the TEST mode, check and repair as needed.
4. After water is supplied, the normal CYCLE is followed: **icemaking** → **Harvest** → **Park Position** → **Fill**.
5. Five seconds after Stage 5 is completed, the Ice Maker returns to MICOM control. The time needed to supply water resets to the pre- test setting.

Diagnosis TABLE

STAGE	ITEMS	INDICATOR	REMARKS
1	HEATER		Five seconds after heater starts, a heater will go off if the temperature by sensor is higher than 10°C
2	MOTOR		Five seconds after heater starts, you can confirm that a motor is moving.
3	HALL IC I		Check if Ice Bin is full or not. If Ice bin is full, the motor and heater are off and on stand by until Ice bin is empty.
4	HALL IC II		You can confirm HALL IC detection of start position.
5	VALVE		Two seconds after detection of start position, you can confirm that valve is on.
6	Reset	Return to Status prior to TEST MODE	Five seconds after fifth stage is completed, The icemaker resets to initial status.

6-7 DEFECT DIAGNOSIS FUNCTION

6-7-1 ERROR CODES shown on Ice Maker water supply control panel

NO	DIVISION	INDICATOR	CONTENTS	REMARKS
1	Normal	Mark time to supply	None	Display switch operates properly
2	Icemaking Sensor malfunction		Open or short-circuited wire	Make sure that the wire on each sensor is connected.

6-8 Hidden Dispenser

6-8-1 Hidden Dispenser Logic

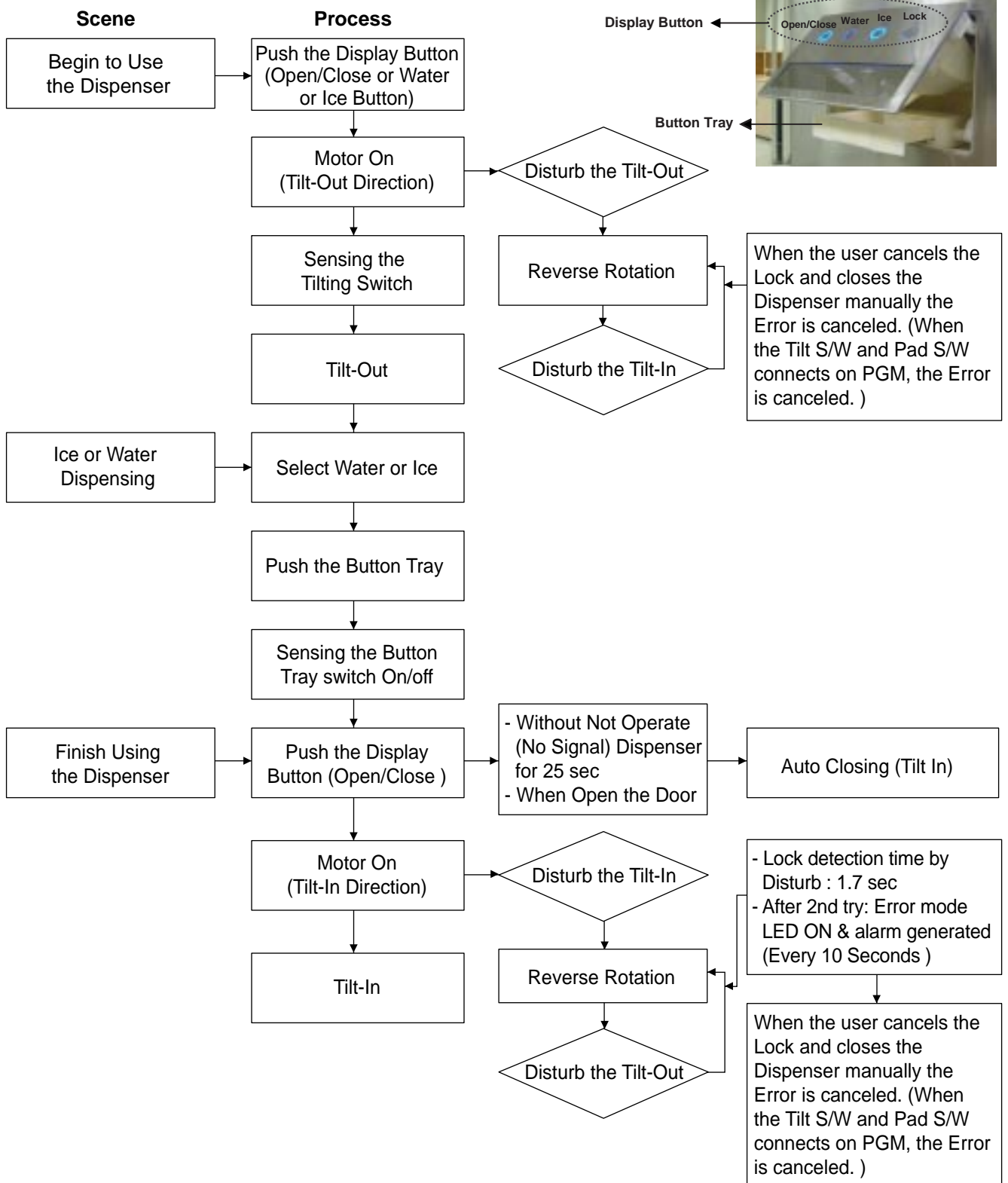

6-9 Hidden Dispenser operation

6-9-1 Open/Close

1. When the power is connected to the refrigerator for the first time, the Dispenser will close once.
2. When you press the Open/Close, Water and Ice Button while the Dispenser is closed, the Dispenser will be opened.
3. When you open the refrigerator Door while the Dispenser is open, the Dispenser will be closed.
4. When the Dispenser and the refrigerator Door is open, the Dispenser will not open.
5. When the Dispenser is open and no additional signal 25 seconds after receiving the operating signal of the Button Tray, the Dispenser will automatically be closed.

6-9-2 Water

1. When you press the Water Button while the Dispenser is closed, the Dispenser will be opened.
2. When the Dispenser is open and when you press the Button Tray while the LED of Water Button is on, water will be dispensed in the Dispenser.
3. When the Dispenser is open and when you press the Water Button while the LED of Ice Button is on, the LED of the Water Button will be turned on.

6-9-3 Ice

1. When you press the Ice Button while the Dispenser is closed, the Dispenser will be open.
2. When the Dispenser is open and when you press the Button Tray while the LED of Ice Button is on, ice will be dispensed in the Dispenser.
3. When the Dispenser is open and when you press the Ice Button while the LED of the Water Button is on, the LED of the Ice Button will be turned on.

6-9-4 Lock

1. When you press the Lock Button for 3 seconds while the Dispenser is closed, the LED of the Lock Button will be turned on and the LED of other button will be turned off to stop operation.
2. While the Dispenser is open, the Lock Button will not be activated even when you press the button.

6-9-5 Button LED

1. When the LED of Open/Close, Water or Ice Button is turned on during normal conditions and the Lock Button activated, only the LED of the Lock Button will be turned on.
2. When there is no additional signal 20 seconds after receiving the operating signal of the Display Button and Button Tray, LED of the Display Button will all be turned off (Sleeping Mode)

* Troubleshooting for Ice & Water Dispenser

⚠CAUTION

1. If the alarm sounds and the back lights (4 buttons) flash, open and close the cover display to reset.
2. If the alarm does not reset by opening and closing the cover display, unplug the refrigerator to reset.

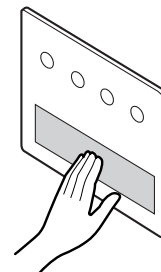

6-10. Error Code Summary

▲WARNING : When you check the Resistance values, be sure to turn off the power.
And wait for the voltage-discharge sufficiently.

NO	Error Detection Category	Error Display		Error Generation Factors	Remark
		Freezer Temperature	Ref. Temperature		
1	Normality			None	Normal operation of Display
2	Freezer Sensor Error	Er	FS	Short or Disconnection of Freezer Sensor	Check each sensor and its connector.
3	Refrigerator Sensor Error	Er	rS	Short or Disconnection of Refrigerator Sensor	
4	Defrosting Sensor Error	Er	dS	Short or Disconnection of Defrosting Sensor	
5	Icing Sensor Error	Er	IS	Short or Disconnection of Icing Sensor	
6	Poor Defrosting	Er	dH	Even though it is passed 1 hour since then Defrosting , if Defrosting sensor is not over 8°C, it is caused	Temperature Fuse Disconnection, Heater disconnection, DRAIN Jam, Poor Relay for Heater
7	Abnormality of BLDC FAN Motor for Ice Making	Er	IF	It is caused when feedback signal isn' t over 65 seconds during BLDC FAN motor operating	Poor BLDC Motor connection, DRIVE IC, and TR
8	Abnormality of BLDC FAN Motor for Freezer	Er	FF	It is caused when feedback signal isn' t over 65 seconds during BLDC FAN motor operating	Poor BLDC Motor connection, DRIVE IC, and TR
9	Abnormality of BLDC FAN Motor for Mechanic Room	Er	CF	It is caused when feedback signal isn' t over 65 seconds during BLDC FAN motor operating	Poor BLDC Motor connection, DRIVE IC, and TR
10	Communication Error	Er	CO	Communication Error between Micom of Main PWB and Display Micom	Poor Communication connection,Poor TR of Transmitter and Receiver

6-11. Troubleshooting With Error

Freezer Sensor Error

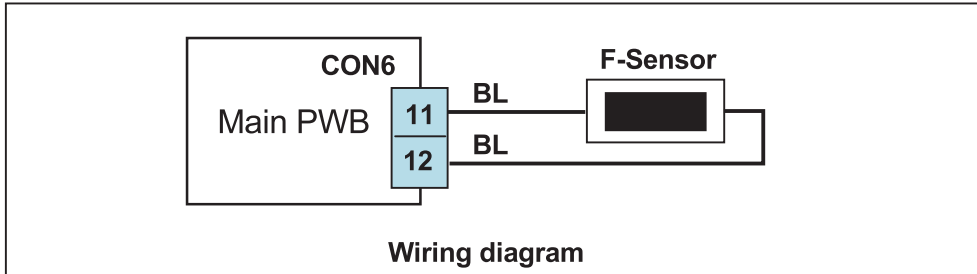

Is Er-FS displayed?

Yes

Is the connection loose?

Yes → Reconnect

CON6

No

Power Off
Tip : To protection of MICOM

Disconnect CON6 and measure the value. Is resistance value between pins 11 & 12 of CON6 as below? (BL to BL)

No

Replace F-sensor (Position No : 610C)



CON6

Test Point	Result
Pin11 to pin12	1.4 ~ 120 kΩ

Yes

Reconnect CON6 and Power ON

If the ER-FS appears, Replace the main PWB. Otherwise, explain to the customer!

Refrigerator Sensor Error

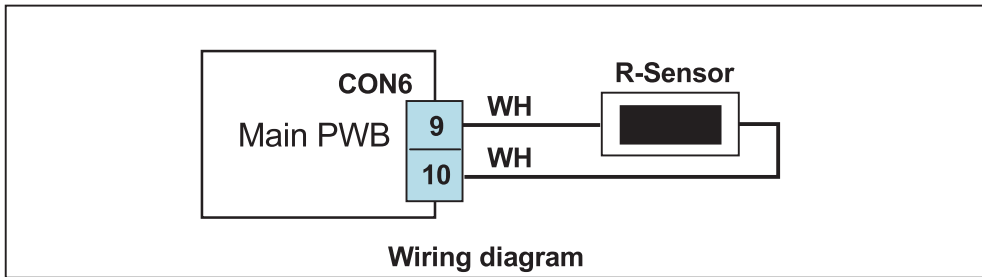

Is Er-FS displayed?



Yes

Is the connection loose?

Yes

Reconnect



CON6

No

Power Off

Tip : To protection of MICOM

Disconnect CON6 and measure the value. Is resistance value between pins 9 & 10 of CON6 as below? (WH to WH)

No

Replace R-sensor (Position No : 610B)

pin9 pin10



CON6

Test Point	Result
Pin9 to pin10	6 ~ 300 kΩ

Yes

Reconnect CON6 and Power ON

If the ER-rS appears, Replace the main PWB. Otherwise, explain to the customer!

Defrost Sensor Error

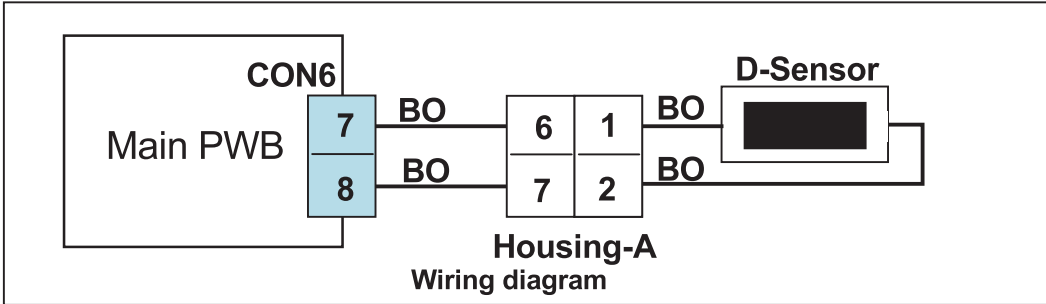

Is Er-dS displayed?

Yes

Is the connection loose?

Yes → Reconnect

CON6

No

Power Off
Tip : To protection of MICOM

Disconnect CON6 and measure the value. Is resistance value between pins 7 & 8 of CON6 as below? (BO to BO)

No → Replace D-sensor (Position No : 400A)

pin7 pin8

CON6

Test Point	Result
Pin7 to pin8	6 ~ 300 kΩ

Yes

Is resistance value between pins 1 & 2 of Housing- A as below? (BO to BO)

No → Replace D-sensor (Position No : 400A)

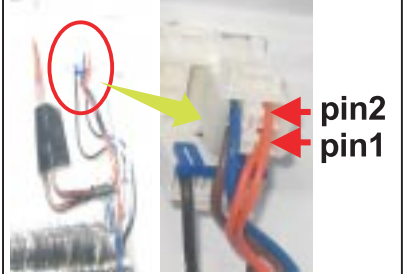

Checking Open or Short of wire

Test Point	Result
Pin1 To pin2	6 ~ 300 kΩ

Yes

Reconnect and Power ON

If the ER-dS appears, Replace the main PWB.(Position No:500A)
Otherwise, explain to the customer!

Icing Room Sensor Error

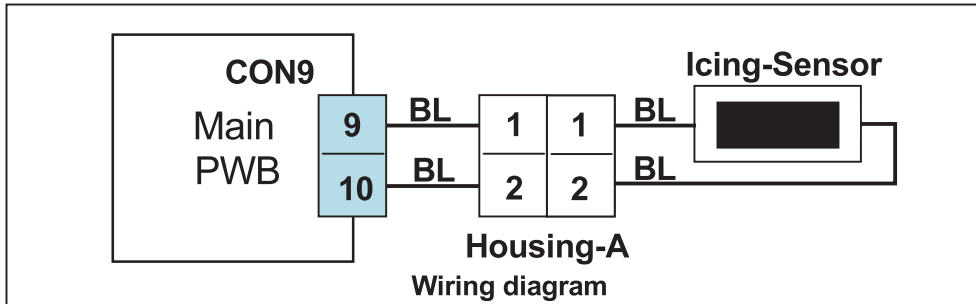

Is Er-IS displayed?

Yes

Is the connection loose?

Yes → Reconnect

Inner of Icing door

Main PWB Con9



CON9

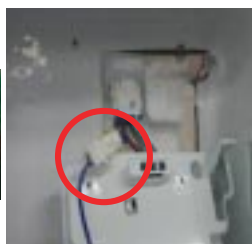

No

Disconnect CON9 and measure the value. Is resistance value between pins 9 & 10 of CON9 as below? (BL to BL)

No

Replace Main PWB
(Position No:500A)



CON9

pin9 BL pin10 BL

Icing room Sensor Resistance

Test Point	Result
Pin9 To Pin10	1.156 ~ 141.5 kΩ

Yes

Is resistance value between pins 1 & 2 of Housing- A as below? (BL to BL)

No

Replace Icing-sensor
(Position No : 600B)

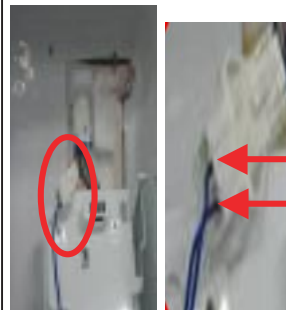

Checking Open or Short of wire

Test Point	Result
(1) To (2)	1.4 ~ 120 kΩ

Yes

Reconnect and Power ON

If the ER-IS appears,
Replace Main PWB
Otherwise, explain
to the customer!

Defrost Heater Error

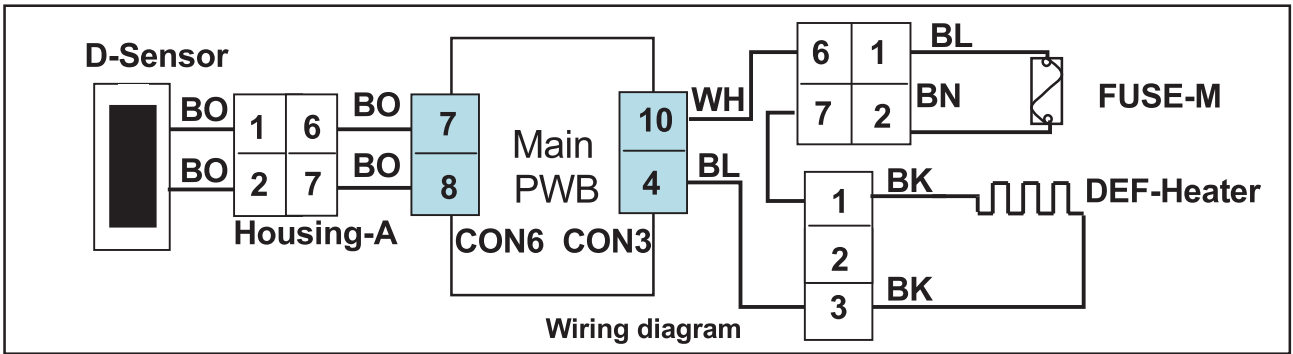

Is Er-dH displayed?

Yes

Is the connection loose?

Yes → Reconnect

CON6

CON3

No

Enter the TEST 3 MODE

Is the voltage value between pins 10(WH) and 4 (BL) of CON3 115 V AC?

No → Replace MAIN PWB (Position No: 500A)

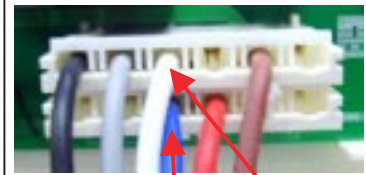

CON3 pin4 BL pin10 WH

Relay operation

Test Point	Result
pin4 To pin10	115V

Yes

Reset TEST3 MODE(Normal)

Is the voltage value between pins 10 (WH) and 4 (BL) of CON3 0 V AC?

No → Replace MAIN PWB (Position No: 500A)



CON3 pin4 BL pin10 WH

Relay Open

Test Point	Result
Reset/Norm OP	0 ~ 2 V

Yes

Is the resistance value between pins 10(WH) And 4(BL) of CON3 like as below?

Yes → Normal



pin10 WH
pin4 BL

CON3

Resistance

Test Point	Result
Pin 4 to Pin 10	34 ~ 42 Ω

No →

Is the connection loose?

Yes → Reconnect

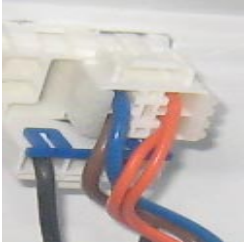

No →

Is the resistance value of Fuse –M like as below?

No → Replace Fuse-M (Position No:400A)

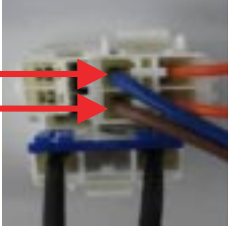

(1) BL
(2) BN

Open or Short of Fuse-M

Test Point	Result
(1) To (2)	0 Ω

Yes →

Is the resistance value of heater like as below?

No → Replace Heater (Position No: 408A)

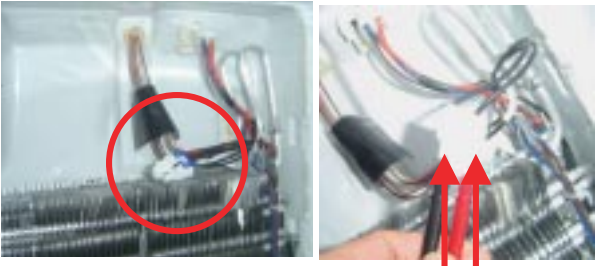

(1)(2)

Heater Resistance

Test Point	Result
(1) To (2)	34 ~ 42 Ω

Yes →

Is the resistance value of DEF-sensor like as below? It depends on the temperature.

No → Replace DEF-sensor



(1) BO
(2) BO

Defrost Sensor Resistance

Test Point	Result	Test Point	Result
-3 °C	X29.3 Ω	10 °C	X9.53 Ω
-20 °C	76.96 Ω	20 °C	X3.03 Ω
-10 °C	47.34 Ω	30 °C	8.896 Ω
0 °C	30 Ω	40 °C	6.20 X Ω

Yes →

Yes → Explain to the customer!
: It can be occurred, when the gasket is not stuck to product or when you put the high temperature loads (hot foods) a lot in the product.

Freezer Fan Error

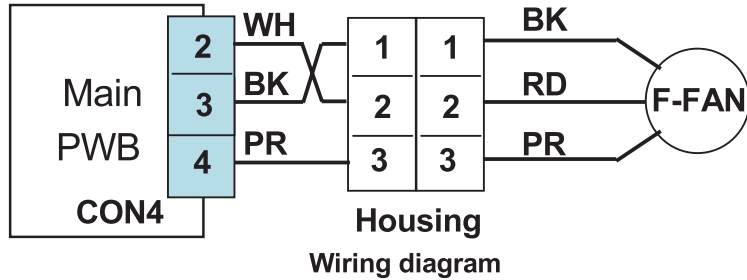

Is Er-FF displayed?

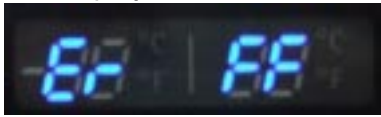

Yes

Is the connection loose?

Yes

Reconnect



CON4

No

Reset and Enter the TEST 1 MODE

Is the output voltage between pin2 and pin3 of CON4 like as below?

Pin2 WH Pin3 BK



Freezer Fan Voltages

Test Point	Result
pin2 To pin3	12 ~ 16 V

Yes

NO

Replace MAIN PWB (Position No: 500A)

Does the cold-air come out of the top of the main duct under Test1 mode ?



Yes

NO

Check fan motor (Connector, Frozen, Locked) and Replace (Position No : 404A)

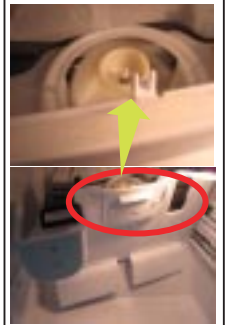

Is the feedback voltage between pin3 and pin4 of CON4 like as below? (from motor to main board)

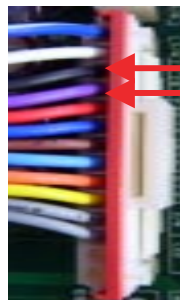

Pin3 BK
pin4 PR

CON4

Feedback Voltages

Test Point	Result
Pin3 To pin4	1 ~ 4 V

No

Replace MAIN PWB (Position No: 500A)

Yes

Explain to the customer!

Condenser Fan Error

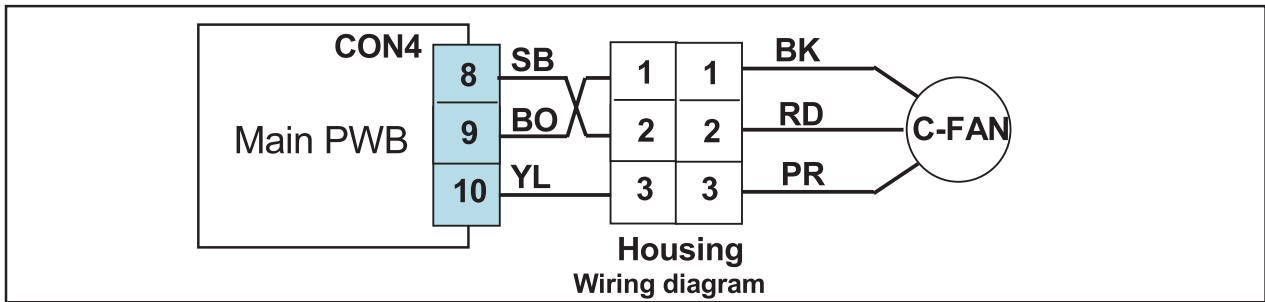

Is Er-CF displayed?

Yes

Is the connection loose?

Yes → Reconnect

No →

Reset and Enter the TEST 1 MODE

Is the output voltage between pin8 and pin9 of CON4 like as below?

Pin8 SB Pin9 BO

Condenser Fan Voltages

Test Point	Result
pin8 To pin9	10 ~ 16 V

Yes

No → Replace MAIN PWB (Position No: 500A)

Is the condenser fan rotate under Test1 mode?

Yes

No → Check fan motor (Connector, Locked, mouse) and replace. (Position No: 420A)

Is the feedback voltage between pin9 and pin10 of CON4 like as below? (from motor to main board)

Pin9 BO
Pin10 YL

Feedback Voltages

Test Point	Result
Pin9 To pin10	1 ~ 4 V

Yes → Explain to the customer!

No → Replace MAIN PWB (Position No: 500A)

Icing Room Fan Error

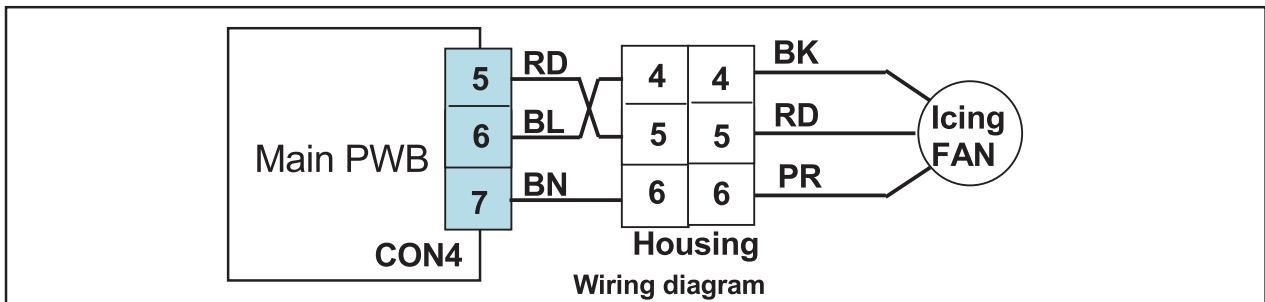

Is Er-IF displayed?



Yes

Is the connection loose?



No

Yes

Reconnect

No

Reset and Enter the TEST 1 MODE
Is the output voltage between pin5 and pin6 of CON4 like as below?

Pin5 RD Pin6 BL



Icing Fan Voltages

Test Point	Result
pin5 To pin6	10 ~ 16 V

Yes

Replace MAIN PWB (Position No: 500A)

Does the cold-air come out of the side duct under the Test1 Mode?



Yes

No

Check fan motor (Connector, Frozen, Locked) and replace. (Position No : 407A)

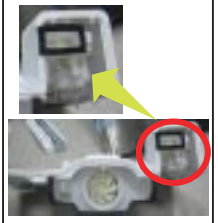

Is the feedback voltage between pin6 and pin7 of CON4 like as below? (from motor to main board)

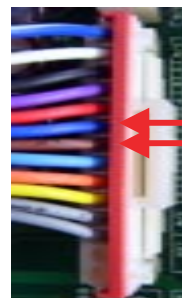

Pin6 BL
Pin7 BN

Feedback Voltages

Test Point	Result
Pin6 To pin7	1 ~ 4 V

Yes

No

Replace MAIN PWB (Position No: 500A)

Explain to the customer!

Communication Error

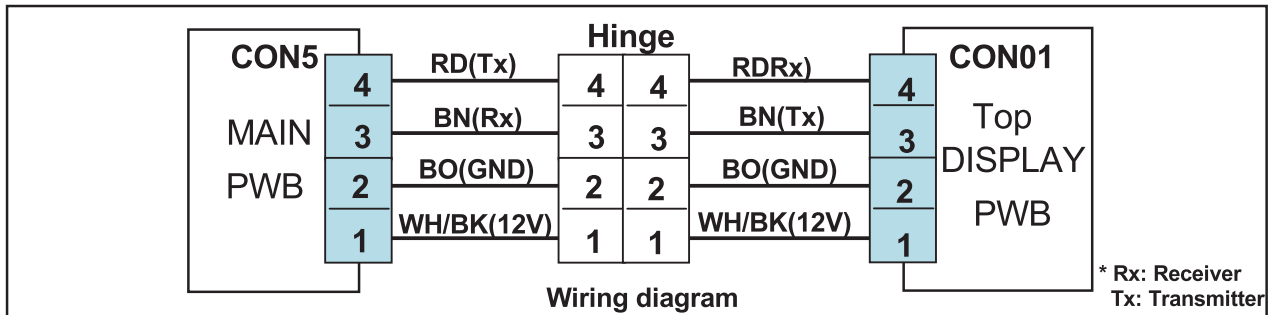

Is Er-CO displayed?

Yes

Top Display PWB
Is the connection loose?



CON01

Yes

Reconnect

No

Top Display PWB
Is the voltage between pins 2 and pin 3 of CON101?

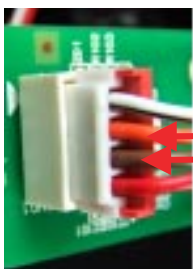

Pin2 BO
pin3 BN

YES

Replace the Top Display PWB
(Position No : 207C)

Receiver fail Voltages

Test Point	Result
pin2 To pin3	0 V or 5 V

No

Top Display PWB
Is the voltage between pin2 and pin4 of CON01 0 V or 5 V?

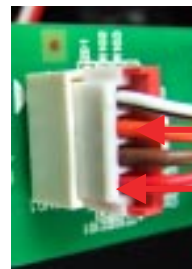

Pin2 BO

Pin4 RD

Transmitter Voltages

Test Point	Result
Pin2 To pin4	0 V or 5 V

Yes

Replace the Top Display PWB
(Position No : 207C)

No

Is the joint connection loose In the right Hinge?



Yes

Reconnect

No

MAIN PWB
Is the connection loose?



Yes → Reconnect

No ↓

Main PWB
Is the voltage between pin 2 and pin 3 of CON5 0V or 5V?

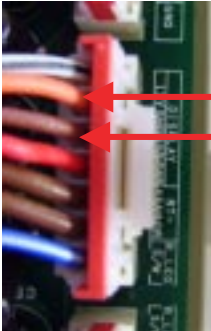

Yes → Replace MAIN PWB (Position No: 500A)

Receiver Voltages

Test Point	Result
pin2 To pin3	0 V or 5 V

No ↓

Main PWB
Is the voltage between pin2 and pin4 of CON5 0 V or 5 V?

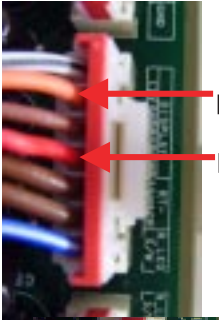

Yes → Replace MAIN PWB (Position No: 500A)

Transmitter Voltages

Test Point	Result
pin2 To pin4	0 V or 5 V

No ↓

After plug in,
If Er-CO is disappeared,
Explain to the customer!

6-12. Troubleshooting Else

ICE Mode doesn't work

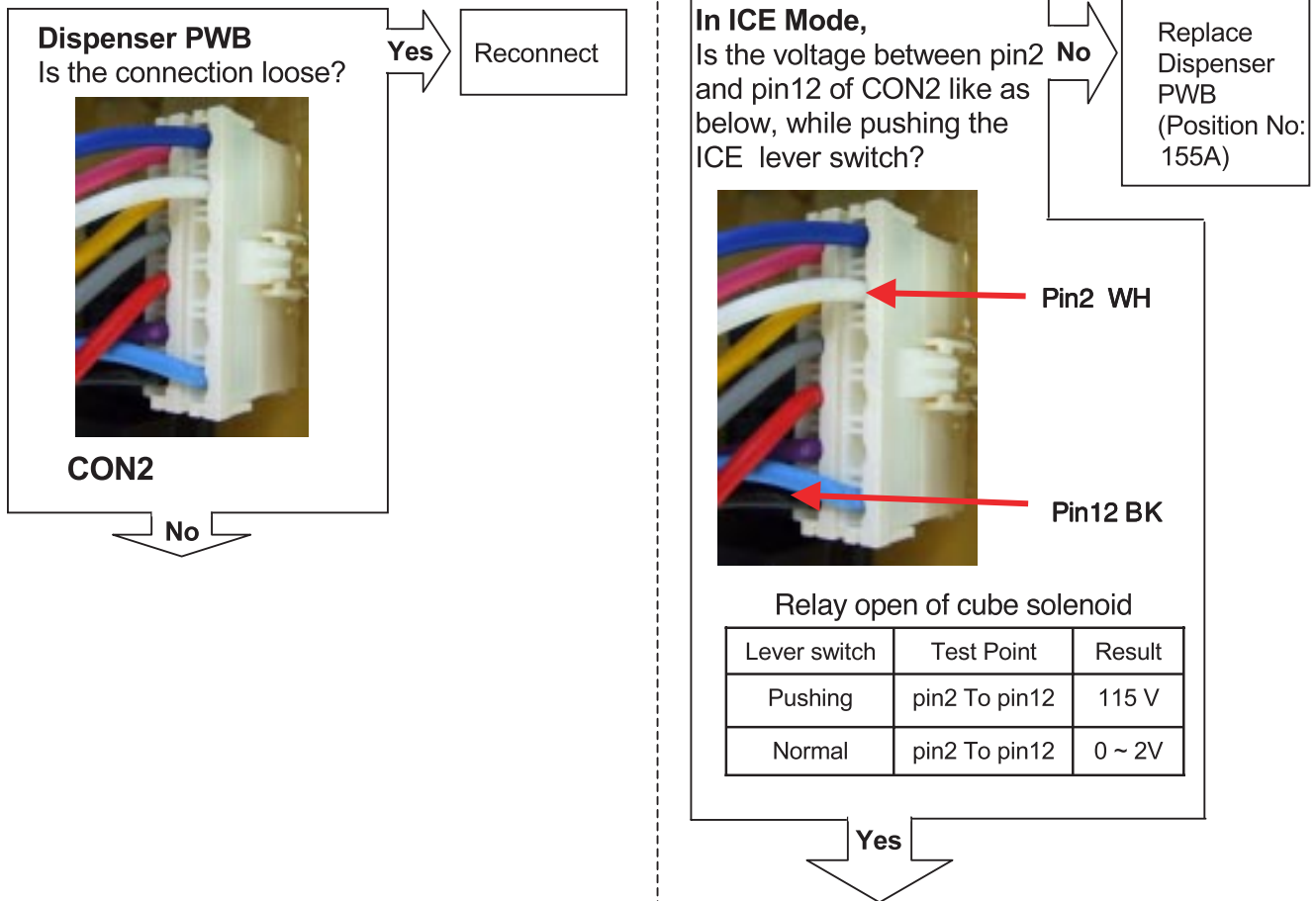
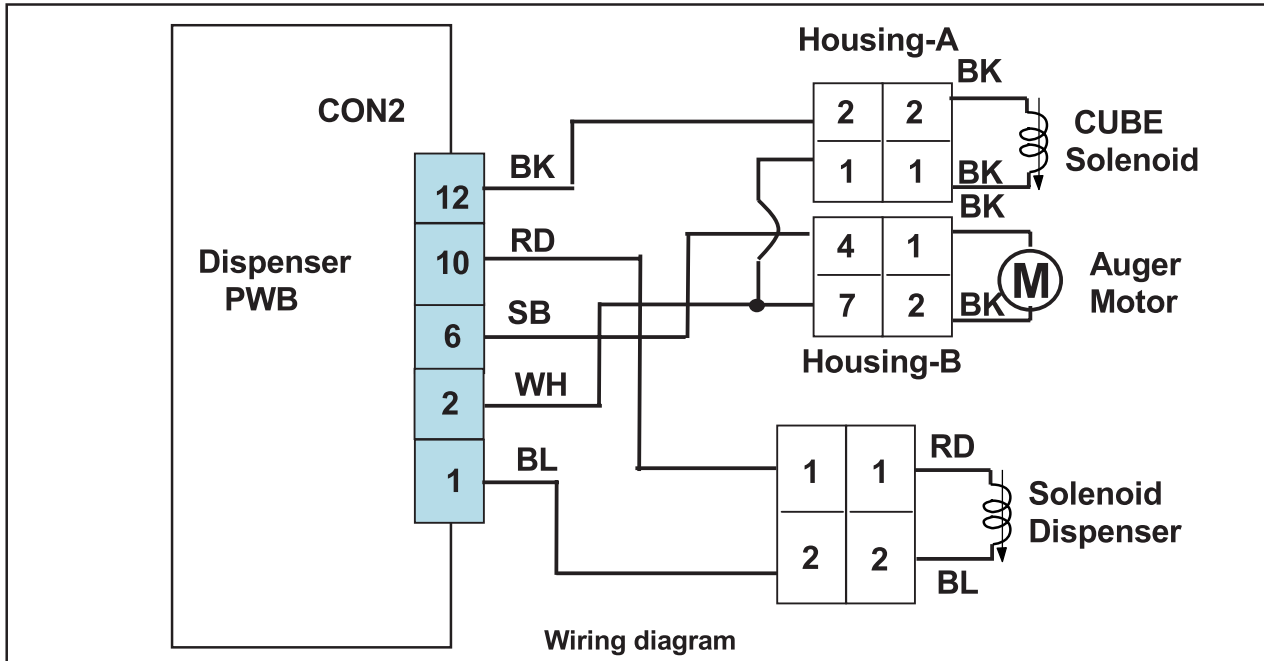

In ICE Mode,
Is the voltage between pin2 and pin6 of CON2 like as below, while pushing the ICE lever switch?

No

Replace Dispenser PWB (Position No: 155A)

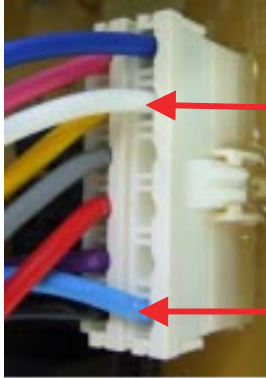

Pin2 WH

Pin6 SB

Output voltage of auger motor

Lever switch	Test Point	Result
Pushing	pin2 To pin6	115 V
Normal	pin2 To pin6	0 ~ 2V

Yes

In CUBE Mode,
Is the voltage between pin2 and pin10 of CON2 like as below, while pushing the ICE lever switch?

No

Replace Dispenser PWB (Position No: 155A)

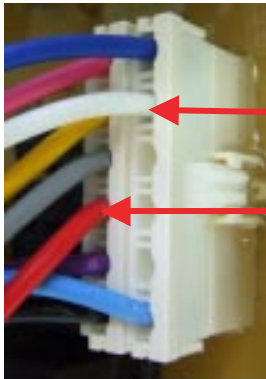

Pin2 WH

Pin10 RD

Output voltage of dispenser solenoid

Lever switch	Test Point	Result
Pushing	pin2 To pin10	115 V
Normal	pin2 To pin10	0V

Yes

Is the resistance value between (1) and (2) of the Auger motor like as below?

No

Replace Auger Motor (Position No: 606A)

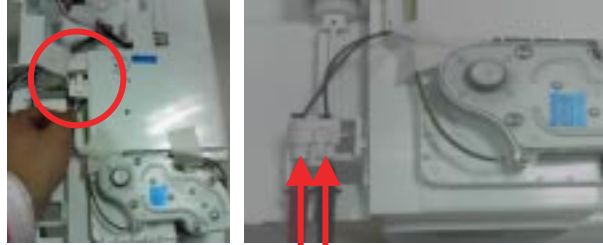

(1)(2)

Resistance of Auger Motor

Test Point	Result
(1) To (2)	2.38 ~ 4.02 Ω

Yes

Is the resistance value between (1) and (2) of the cube solenoid like as below?

No

Replace Cube Solenoid (Position No: 614A)



(1)(2)

Resistance of Cube solenoid

Test Point	Result
(1) To (2)	32 ~ 40 Ω

Yes

Is the resistance between (1) and (2) of the Dispenser solenoid like as below?

No

Replace Dispenser Solenoid (Position No: 405A)

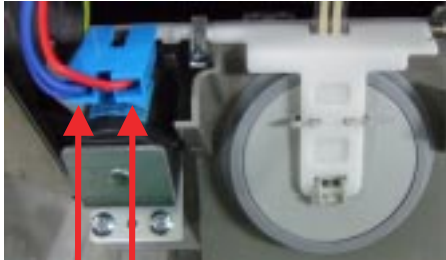

(1) (2)

Resistance of Dispenser solenoid

Test Point	Result
(1) To (2)	44 ~ 54 Ω

Yes

Is the condition of the micro switch like as below?

No

Replace Micro Switch (Position No:402C)



(1)
(2)

Status	Tester
Normal	Infinity
Push the Lever	0 Ω

Yes

After plug in, explain to the customer!

Water Mode Doesn't work

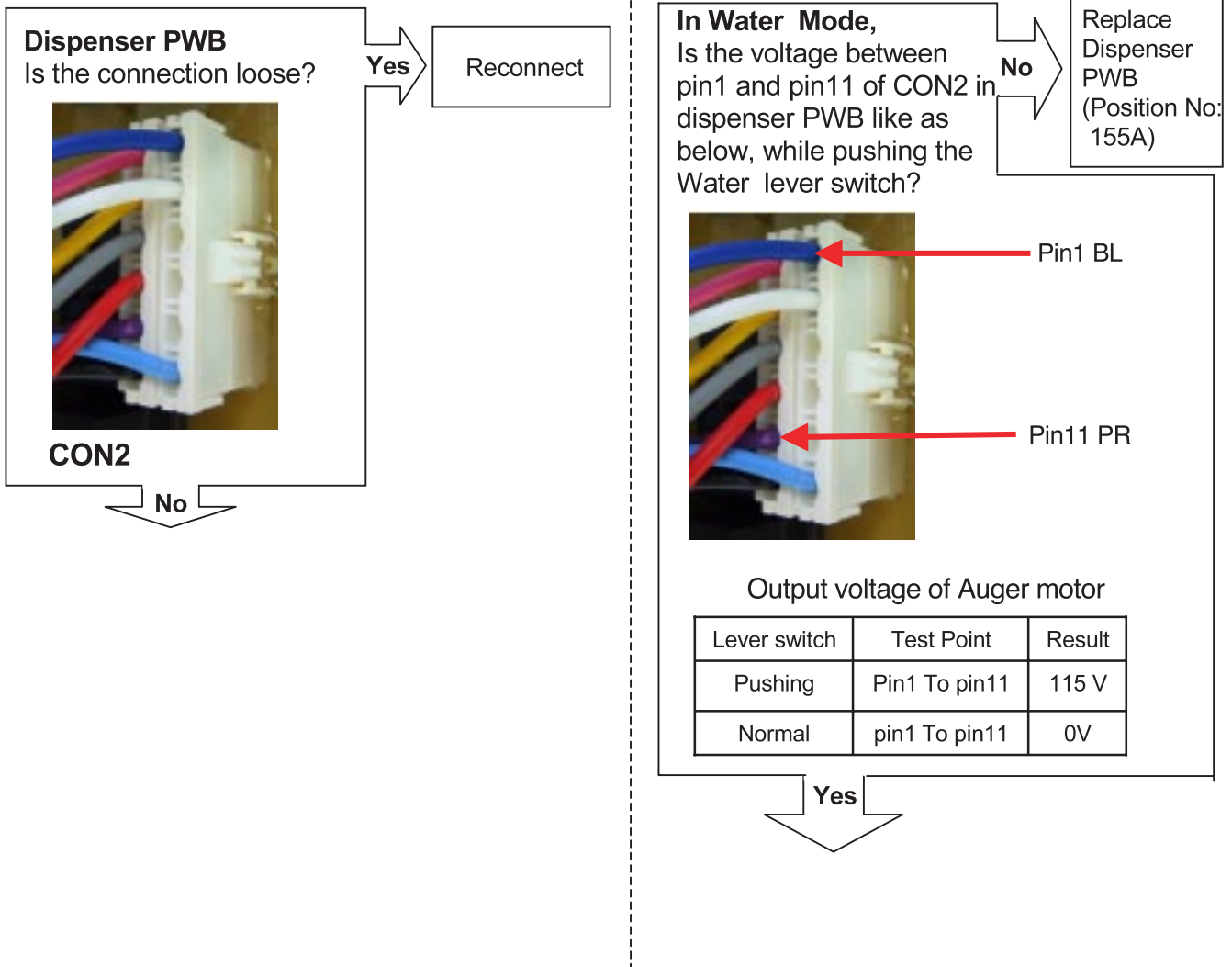
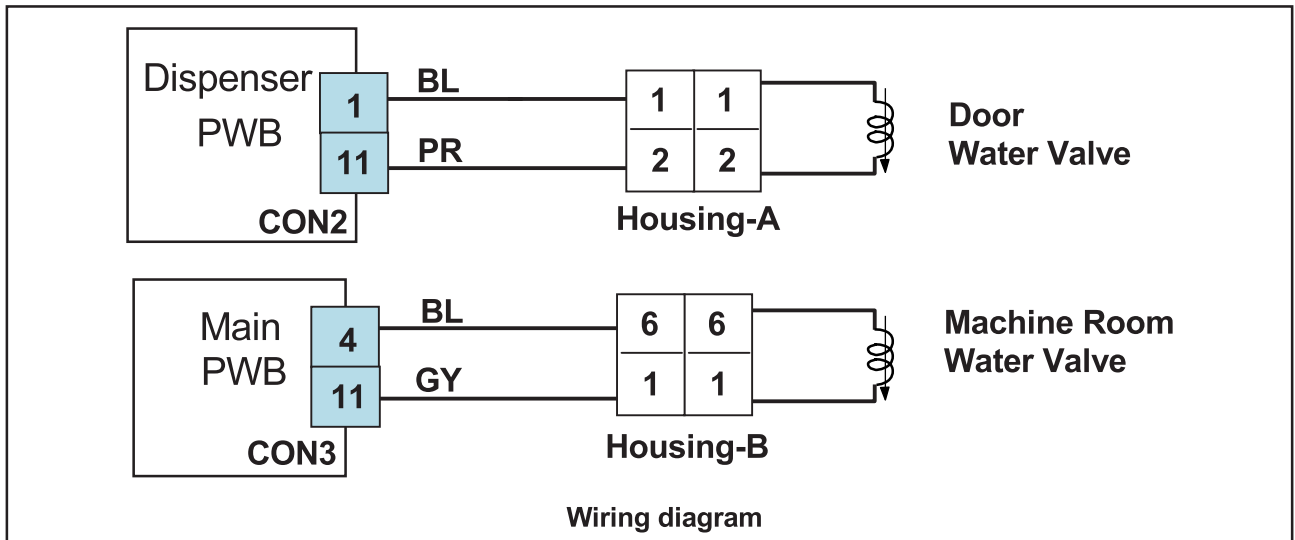

In Water Mode,
Is the voltage between pin4 and pin11 of CON3 in main PWB like as below, while pushing the level switch?

No → Replace MAIN PWB (Position No: 500A)



Main PWB CON3
Pin11 GY
Pin4 BL

Output voltage of machine room water valve

Test Point	Result
Pin4 To pin11	115 V

Yes →

First Water- valve
Is the resistance value between (1) and (2) of the First-water valve like as below?

No → Replace First Water-valve (Position No 619A)

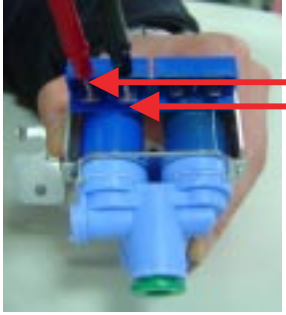

(1)
(2)

Machine room

Checking resistance of First-valve

Test Point	Result
(1) To (2)	360 ~ 420 Ω

Yes →

Second Water- valve
Is the resistance value of Second-water valve like as below?

No → Replace Second Water-valve (Position No: 619B)

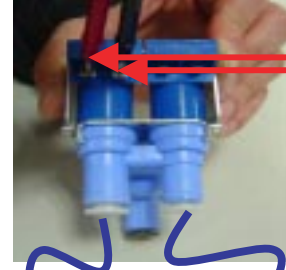

(1)
(2)

In door

Dispenser

Ice Maker

Checking resistance of Second-valve

Test Point	Result
(1) To (2)	360 ~ 420 Ω

Yes →

Is the condition of the micro switch like as below?

No → Replace Micro Switch (Position No:402C)

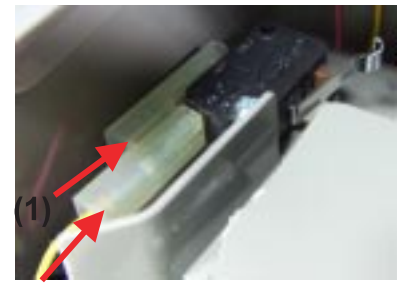

(1)
(2)

Status	Tester
Normal	Infinity
Push the Lever	0 Ω

Yes →

After plug in, explain to the customer!

Freezer-LED Module Doesn't work

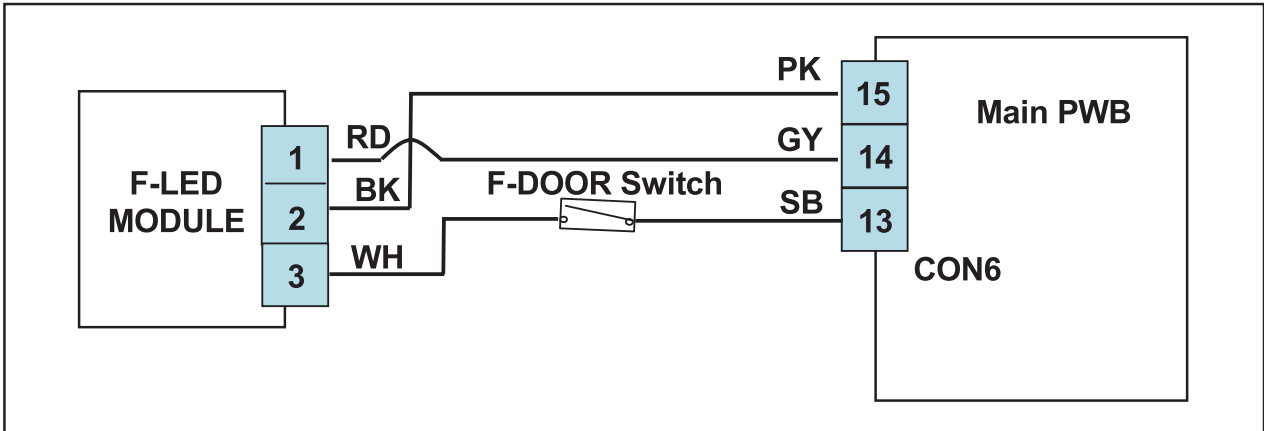

Is the condition of the freezer door switch like as below?

No → Replace Door switch (Position No: 406B)

Status	Tester
Normal	0 Ω
Push the Switch	Infinity

Yes →

Is the voltage between pin 14 and pin15 of CON6 like as below?

No → Replace MAIN PWB (Position No: 500A)

CON6 pin14 GY pin15 PK

Voltage of Freezer LED

Door	Test Point	Result
Don' t Care	pin14 To pin15	12 V

Yes →

Is the connection loose?

Yes → Reconnect

CON6

No →

Is the voltage between pin 1 and pin2 of Freezer LED Module Housing?

No → 1. Check the harness open or short
2. Replace F LED Module (Position No : 409E)

Pin2 BK Pin1 RD

Voltage of Freezer LED

Door	Test Point	Result
Don't care	pin1 To pin2	12 V

Yes →

Is the voltage between pin2 and pin3 of Freezer LED Module Housing?

No → 1. Check the harness open or short

Pin3 WH Pin2 BK

Voltage of Door S/W Signal

Door	Test Point	Result
Close	pin2 To pin3	0 V
Open	pin2 To pin3	12 V

Yes →

Is the voltage between pin 13 and pin15 of CON6 like as below?

No → Replace MAIN PWB (Position No: 500A)

CON6 pin13 SB pin15 PK

Voltage of Door Switch

Door	Test Point	Result
Don't Care	pin13 To pin15	12 V

Yes →

Replace F LED Module (Position No:409E)

Refrigerator-LED Module Doesn't work

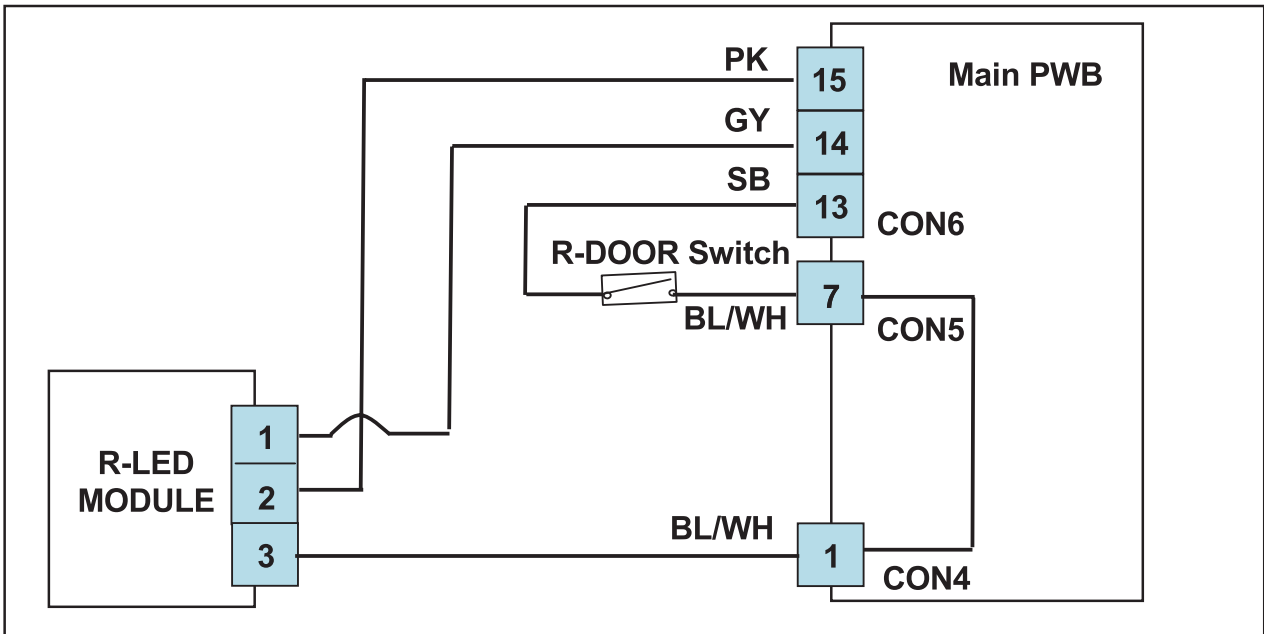

Is the condition of the freezer door switch like as below?

No

Replace Door switch (Position No: 402A)

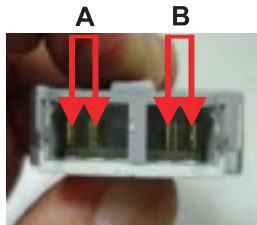

Status	Tester
Normal	0 Ω
Push the Switch	Infinity

Yes

Is the connection loose?

Yes

Reconnect



CON6

No

Is the voltage between pin 14 and pin 15 of CON6 like as below?

No

Replace MAIN PWB (Position No: 500A)



CON6 pin14 GY pin15 PK

Voltage of Refrigerator LED

Door	Test Point	Result
Don't Care	pin14 To pin15	12 V

Yes

Is the voltage between pin 1 and pin2 of Refrigerator LED Module Housing?

No

1. Check the harness open or short
2. Replace R LED Module (Position No : 409D)

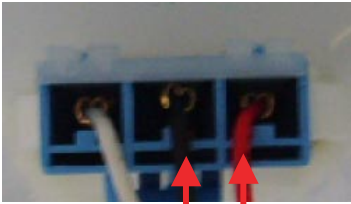

Pin2 BK Pin1 RD

Voltage of Refrigerator LED

Door	Test Point	Result
Don't care	pin1 To pin2	12 V

Yes

Is the connection loose?

Yes

Reconnect



CON6

No

Is the voltage between pin 13 and 15 of CON6 like as below?

No

Replace MAIN PWB (Position No: 500A)



CON6

pin13 SB Pin15 PK

Voltage of Door S/W Signal

Door	Test Point	Result
Don't care	pin13 To pin15	12V

Yes

Is the connection loose?

Yes

Reconnect



CON5

No

Is the voltage between pin 6 and 7 of CON5 like as below?

No

Replace MAIN PWB (Position No: 500A)



CON5

pin6 BN Pin7 BL/WH

Voltage of Door S/W Signal

Door	Test Point	Result
Close	pin6 To pin7	0 V
Open	pin6 To pin7	12 V

Yes

Is the connection loose? **Yes** → Reconnect



CON4

No

Is the voltage between pin 1 and 14 of CON4 like as below? **No** → Replace MAIN PWB (Position No: 500A)



CON4 pin1 BL/WH Pin14

Aoltage of Door S/W Signal

Door	Test Point	Result
Close	pin1 To pin14	0 V
Open	pin1 To pin14	12 V

Yes

Is the voltage between pin2 and pin3 of Refrigerator LED Module Housing? **No** → Check the harness open or short

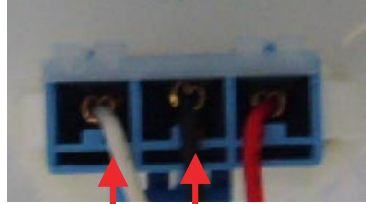

Pin3 WH Pin2 BK

Voltage of Door S/W Signal

Door	Test Point	Result
Close	pin2 To pin3	0 V
Open	pin2 To pin3	12 V

Yes

Replace R LED Module (Position No:409D)

Poor cooling in the refrigerator compartment

MAIN PWB
Is the connection loose?



CON3

No

Yes

Reconnect

Enter the TEST 1 MODE

Is the voltage between
Pins 4 and pin 12 of
CON3 like as below?



CON3

Pin12 BK Pin4 BL

Voltage of Compressor

Test Point	Result
Pin4 To pin12	115 V

Yes

No

Replace
MAIN PWB
(Position No:
500A)

Is the voltage between
pins 2 and pin 3 of CON4
like as below?



CON4

Voltage of F-fan

Test Point	Result
Pin2 To pin3	12 ~ 16 V

Yes

NO

Replace
MAIN PWB
(Position No:
500A)

Feedback check.

Is the voltage between
Pin 3 and pin 4 of CON4
like as below?



CON4

Test Point	Result
pin3 To pin4	1 ~ 4 V

Yes

No

Replace
MAIN PWB
(Position No:
500A)

Does the cold-air come out of the top of the main duct? **No** → Check the Damper itself

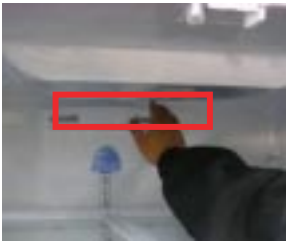

Yes

Enter the TEST 2 MODE
Does not cold-air come out of the top of the main duct? **Yes** → Check the Damper itself



No

Checking Damper itself
Is the resistance Values between (1) & (4), (2) & (3) like as below? **No** → Replace Damper (Position No:120A)

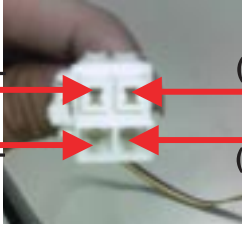

Resistance of Damper



Test Point	Result
(1) To (4)	373 ~ 456 Ω
(2) To (3)	373 ~ 456 Ω

Yes

After reset the unit, take steps to PWB as follows for temperature compensation.

- In the case of EBR419564
: Compensate with Jump wire cutting



JUMP WIRE	Temp. Compensation
	-1.0 deg
	-1.0 deg
Cutting both jumpers affords a 2° temperature compensation	

*** Cutting of jumper wire**

Over cooling in the refrigerator compartment

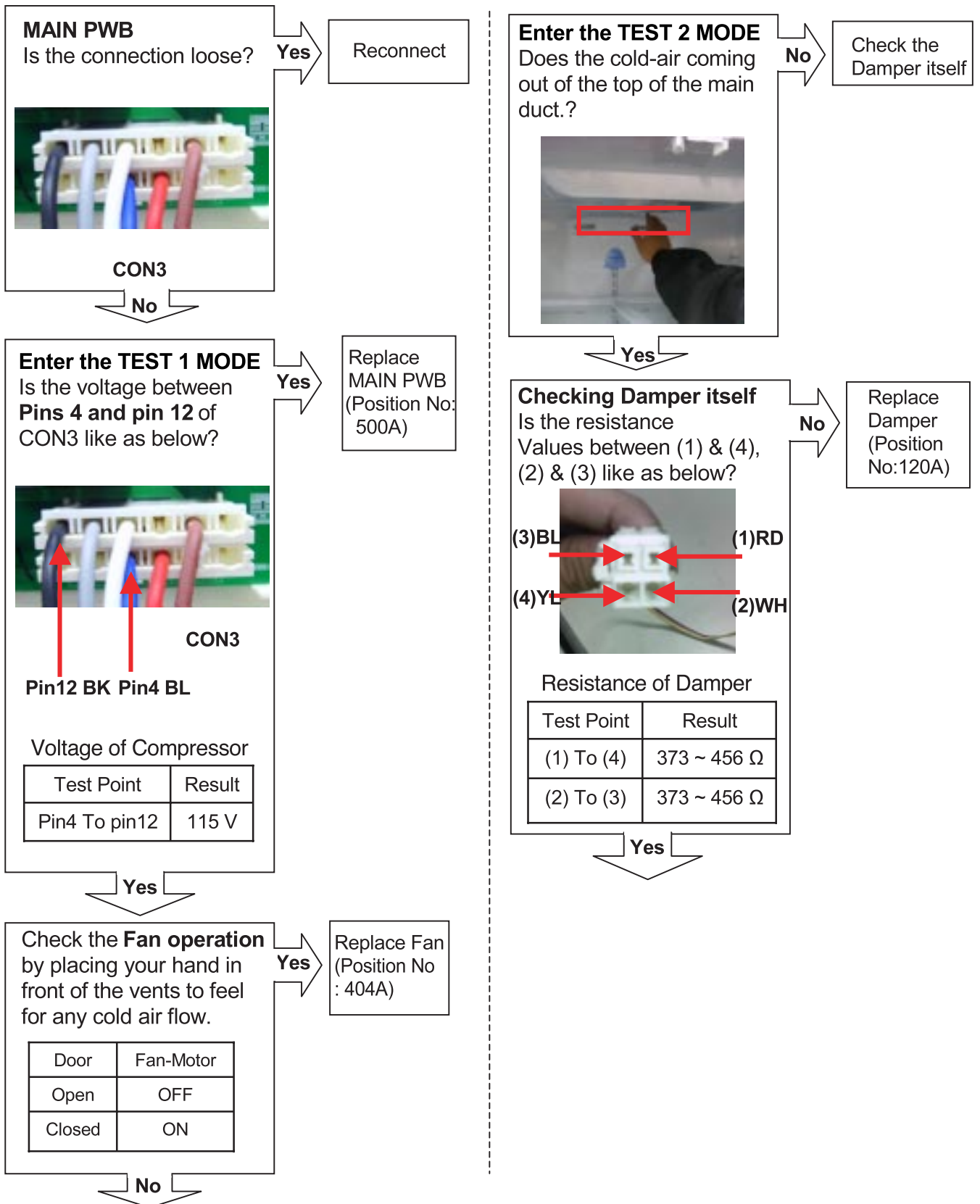

Enter the TEST 3 MODE

Is the voltage between
Pins 4 and pin 12 of
CON3 like as below?

Yes

Replace
MAIN PWB
(Position No:
500A)

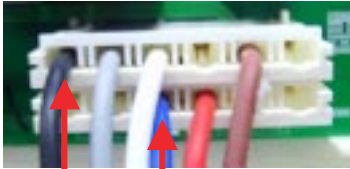

CON3

Pin12 BK Pin4 BL

Voltage of Compressor



Test Point	Result
Pin4 To pin12	0~2 V

Yes

After reset the unit, take steps to PWB as follows for temperature compensation.

1. In the case of EBR419564
: Compensate with Jump wire cutting



JUMP WIRE	Temp. Compensation
	+1.0 deg
	+1.0 deg
Cutting both jumpers affords a 2° temperature compensation	

*** Cutting of jumper wire**

[NOTE]

1. How To Remove Terminal Position Assurance (TPA)

* AC TPA



* DC TPA

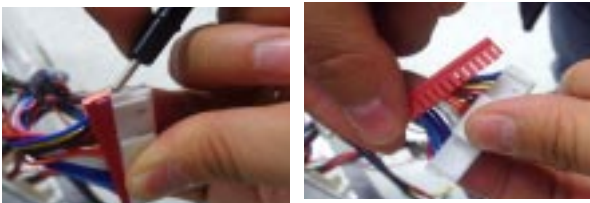

△ After measure the values, you should put in the TPA again.

2. Wire Color

- BL: Blue
- WH: White
- BO: Bright Orange
- BK: Black
- BN: Brown
- PR: Purple
- RD: Red
- GN: Green
- SB: Sky Blue
- GY: Gray
- BL/WH : Blue & White

2. How To Start Test Mode
Push the TEST button on the Main PWB,
You can start the TEST MODE.



* 1 time : Comp / Damper / All FAN on,
(All things displayed)



* 2 times : Damper closed
(22 22 displayed)



* 3 times : Forced forced defrost mode
(33 33 displayed)

6-13. How to check the Fan-Error

(1) EBR419564

After sending a signal to the fan, the MICOM checks the BLDC fan motor's lock status. If there is no feedback signal from the BLDC fan, the fan motor stops for 10 seconds and then is powered again for 15 seconds. To determine that there is a fan motor malfunction, this process is repeated 3 times. If the fan motor is determined to be defective, the error code will be shown in the display for 30 minutes. At this point, the process will be repeated until the fan motor operates normally. If normal operation is achieved, the error display is erased and the MICOM is reset automatically.

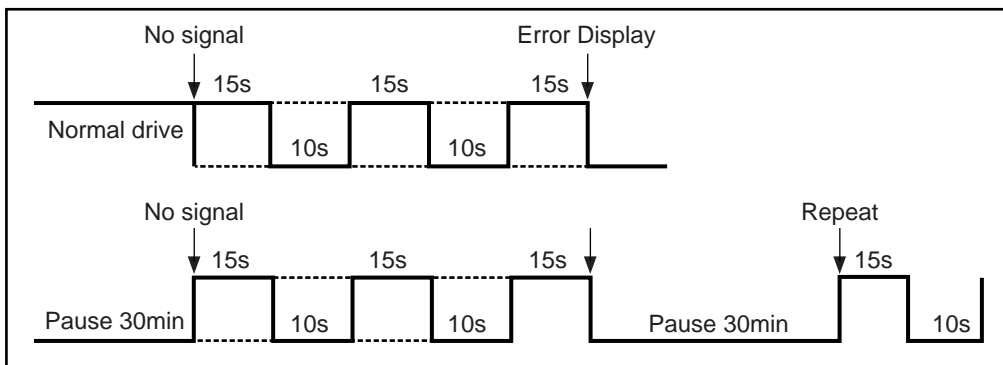

7. COMPONENT TESTING INFORMATION

7-1. Defrost Controller Assembly

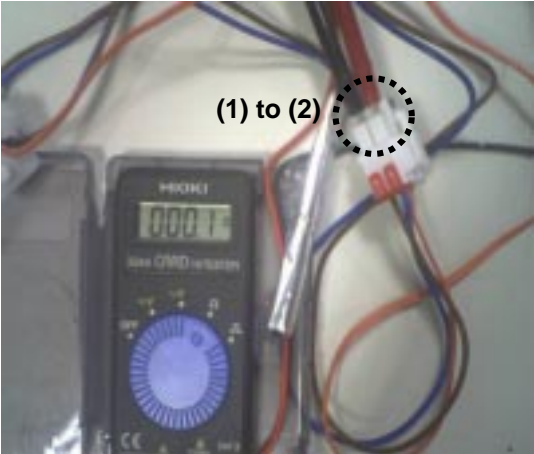
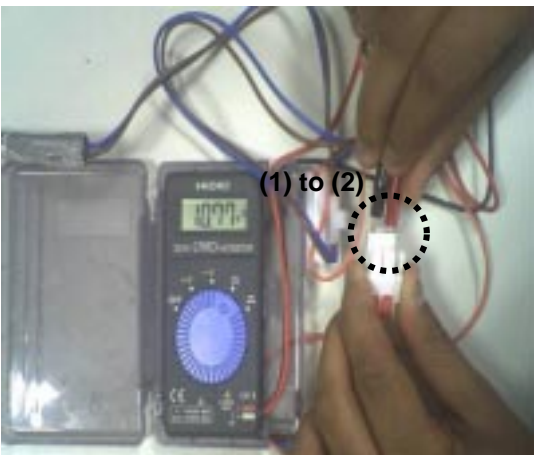
<p>Function</p>	<ul style="list-style-type: none"> - Controller assembly is consist of 2 kinds of part those are fuse-m and sensor. we can decide part is defect or not when we check the resistance. - Fuse-m can cut off the source when defrost heater operate the unusual high temperature. - Sensor give temperature information to Micom 									
<p>How to Measure (Fuse-M)</p>		<p>Set a ohmmeter to the 2 housing pin. Measure the 2 pin connected to Fuse-M. If the ohmmeter indicate below 0.1ohm fuse-m is a good condition, But infinitely great ohm Fuse-M is disconnection</p>								
<p>How to Measure (Sensor)</p>		<p>Set a ohmmeter to The 2housing pin. Measure the 2 pin connected to Sensor. If the ohmmeter indicate 11k% (at room temperature) Sensor is not a defect. When check the ohm at other temperature Check the sensor manual.</p>								
<p>Standard</p>	<p>Fuse-M (at all temperature)</p> <table border="1" data-bbox="440 1648 839 1744"> <thead> <tr> <th>Test Point</th> <th>Result</th> </tr> </thead> <tbody> <tr> <td>(1) to (2)</td> <td>0 ~0.1 ‰</td> </tr> </tbody> </table>	Test Point	Result	(1) to (2)	0 ~0.1 ‰	<p>Sensor (at room temperature)</p> <table border="1" data-bbox="975 1648 1374 1744"> <thead> <tr> <th>Test Point</th> <th>Result</th> </tr> </thead> <tbody> <tr> <td>(1) to (2)</td> <td>11 ‰</td> </tr> </tbody> </table>	Test Point	Result	(1) to (2)	11 ‰
Test Point	Result									
(1) to (2)	0 ~0.1 ‰									
Test Point	Result									
(1) to (2)	11 ‰									



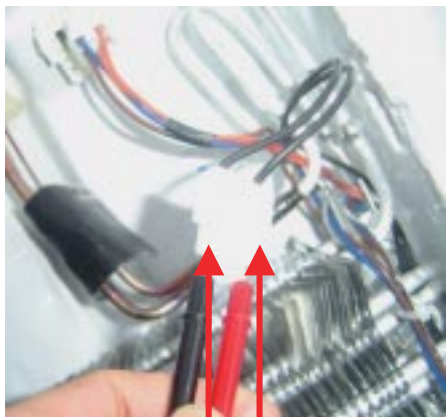

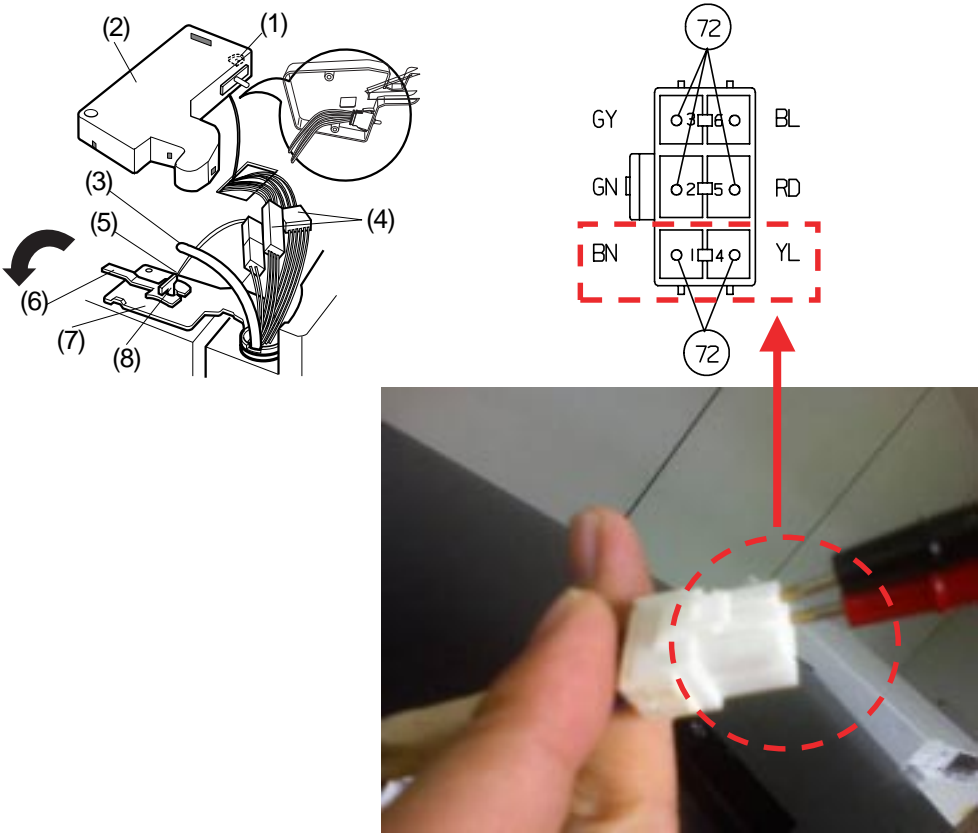

7-2. Sheath Heater

<p>Function</p>	<p>Sheath heater is a part for defrost. All heating wire is connected to only one line. So we can decide part is defect or not when we check the resistance.</p>				
<p>How to Measure</p>	<div style="display: flex; justify-content: space-around;">   </div> <p>Set a ohmmeter connect to The 2 housing pin. Measure the 2 pin connected to Sheath Heater. If the ohmmeter indicate (VXV)/Watt=R is good condition, ex) when watt=350w, voltage=115v $R=(115 \times 115) / 350 = 38\%$ But the ohmmeter indicate infinitely great Sheath heater is disconnection</p>				
<p>Standard</p>	<p>Sheath heater (at all temperature)</p> <table border="1" data-bbox="435 1438 836 1536"> <thead> <tr> <th>Test Point</th> <th>Result</th> </tr> </thead> <tbody> <tr> <td>(1) to (2)</td> <td>34 ~42 ‰</td> </tr> </tbody> </table>	Test Point	Result	(1) to (2)	34 ~42 ‰
Test Point	Result				
(1) to (2)	34 ~42 ‰				

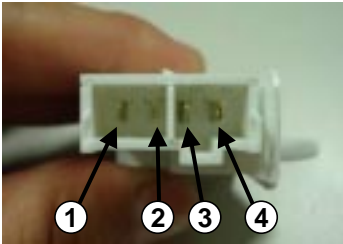
7-3. Door Heater Assembly

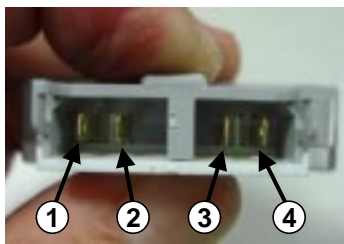
Function	The heater is designed to prevent the raising dew from door.				
How to Measure	 <p>The diagram illustrates the door heater assembly and its electrical connections. The assembly is shown with numbered callouts (1) through (8) indicating various components and connection points. The wiring diagram shows a connector with six terminals: GY (Green-Yellow), GN (Green-Black), BN (Black-White), BL (Black-Blue), RD (Red-Black), and YL (Yellow-Black). Test points 72 are indicated at the top and bottom of the connector. A red dashed box highlights the BN and YL terminals, and a red arrow points to a photograph of a hand holding the white connector, with a red dashed circle highlighting the terminals.</p>				
Standard	<table border="1" data-bbox="443 1429 842 1529"> <thead> <tr> <th>Test Point</th> <th>Result</th> </tr> </thead> <tbody> <tr> <td>(1) to (2)</td> <td>2.3 ~2.9 k%</td> </tr> </tbody> </table>	Test Point	Result	(1) to (2)	2.3 ~2.9 k%
Test Point	Result				
(1) to (2)	2.3 ~2.9 k%				

7-4. Door Switch

<p>Function</p>	<p>The switch sense if the door open or close. - When the door open, lamp on. - When the door open, the switch give information to Micom. When the door open, internal contact operate on and off moving plunger of door switch up and down.</p>				
<p>How to Measure</p>	<div style="display: flex; justify-content: space-around;"> <div style="text-align: center;"> <p><Switch, Freezer></p>   </div> <div style="text-align: center;"> <p><Switch, Refrigerator></p>   </div> </div> <div style="display: flex; justify-content: space-around; margin-top: 20px;"> <div style="text-align: center;">  <p>Beep</p> </div> <div style="text-align: center;">  </div> <div style="text-align: center;">  <p>Beep</p> </div> <div style="text-align: center;">  </div> </div> <p>Check the resistance between connectors 1,2 and 3,4 .It means check whether or not applying an electric current. If there is resistance, it means the switch not inferiority</p>				
<p>Standard</p>	<p>Multimeter beep — Switch F,R</p> <table border="1" style="width: 100%; border-collapse: collapse;"> <tr> <td style="width: 50%; text-align: center;">Nomal</td> <td style="width: 50%; text-align: center;">Push the button(Plunger)</td> </tr> <tr> <td style="text-align: center;">Beep or 0 ‰</td> <td style="text-align: center;">None (‰)</td> </tr> </table>	Nomal	Push the button(Plunger)	Beep or 0 ‰	None (‰)
Nomal	Push the button(Plunger)				
Beep or 0 ‰	None (‰)				

7-5. Solenoid

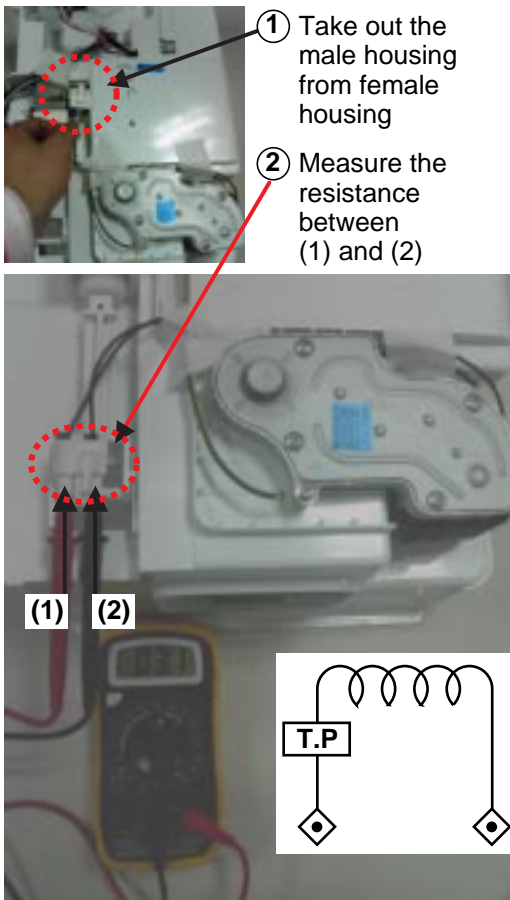
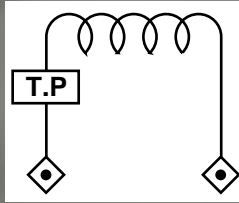
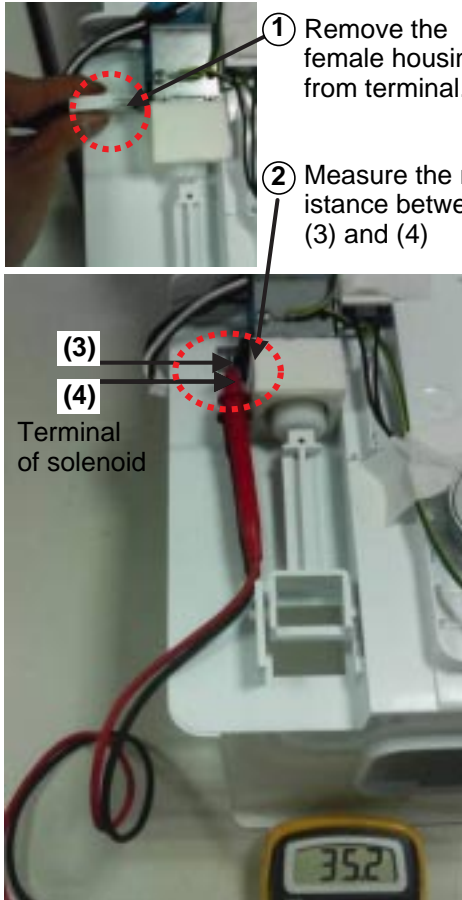

Function	- Dispenser solenoid : When customer push the dispenser button, Pull duct door and abstract from ice bank.						
How to Measure	<div style="text-align: center;">  <p>Dispenser Solenoid</p> </div>						
Standard	<table border="1" style="margin-left: auto; margin-right: auto;"> <thead> <tr> <th colspan="2" style="text-align: center;">Dispenser Solenoid</th> </tr> <tr> <th style="text-align: center;">Test Points</th> <th style="text-align: center;">Result</th> </tr> </thead> <tbody> <tr> <td style="text-align: center;">(1) to (2)</td> <td style="text-align: center;">44 ~ 54 ‰</td> </tr> </tbody> </table>	Dispenser Solenoid		Test Points	Result	(1) to (2)	44 ~ 54 ‰
Dispenser Solenoid							
Test Points	Result						
(1) to (2)	44 ~ 54 ‰						

7-6. AC Motor ASSEMBLY (Geared Motor & Solenoid)

<p>Function</p>	<p>The Geared Motor of ac motor assembly advances forward the ice by rotating the ice and The solenoid of ac motor assembly selects one of the cube mode or crush mode.</p> <p>- Cube solenoid : Pulling the stir lip for moving the ice in ice maker system.</p>									
<p>How to Measure</p>	<p>< Geared Motor ></p>  <p>① Take out the male housing from female housing</p> <p>② Measure the resistance between (1) and (2)</p> <p>(1) (2)</p> 	<p>< Cube Solenoid ></p>  <p>① Remove the female housing from terminal.</p> <p>② Measure the resistance between (3) and (4)</p> <p>(3) (4)</p> <p>Terminal of solenoid</p>								
<p>Standard</p>	<p style="text-align: center;">Geared Motor</p> <table border="1" style="margin-left: auto; margin-right: auto;"> <thead> <tr> <th>Test Points</th> <th>Result</th> </tr> </thead> <tbody> <tr> <td>(1) to (2)</td> <td>2.38 ~ 4.02 %</td> </tr> </tbody> </table>	Test Points	Result	(1) to (2)	2.38 ~ 4.02 %	<p style="text-align: center;">Cube Solenoid</p> <table border="1" style="margin-left: auto; margin-right: auto;"> <thead> <tr> <th>Test Points</th> <th>Result</th> </tr> </thead> <tbody> <tr> <td>(3) to (4)</td> <td>32 ~ 40 %</td> </tr> </tbody> </table>	Test Points	Result	(3) to (4)	32 ~ 40 %
Test Points	Result									
(1) to (2)	2.38 ~ 4.02 %									
Test Points	Result									
(3) to (4)	32 ~ 40 %									

Check the resistance between connectors (Geared motor 1,2) and (solenoid 3,4).It means check whether or not applying an Electric current. If there is resistance, it means the geared motor or solenoid is not inferiority

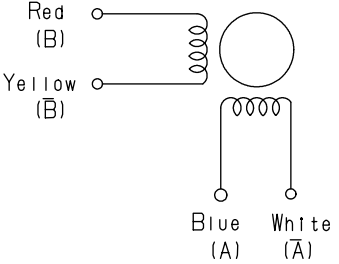
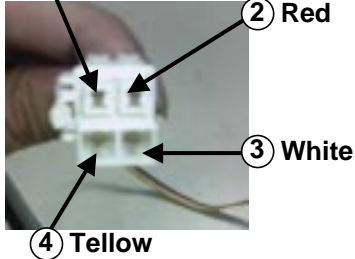
7-7. Damper

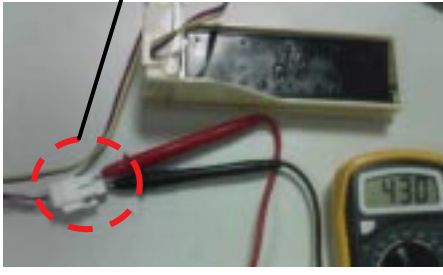
<p>Function</p>	<p>The damper supplies the cold air at freezer room to chillroom by using the damper s plate. Chillroom is colder than before when damper s plate is open. When damper s plate is close, chillroom s temperature will rise.</p>																													
<p>How to Measure</p>	<div style="display: flex; justify-content: space-around;"> <div data-bbox="435 539 855 929"> <p>Table(1): 결선도(Wiring)</p>  </div> <div data-bbox="895 568 1374 862"> <p>Table(2): 2-2상 여자순서(CW Rotation)</p> <table border="1"> <thead> <tr> <th rowspan="2">Housing No. & L/Wire Color</th> <th colspan="4">Step</th> </tr> <tr> <th>1</th> <th>2</th> <th>3</th> <th>4</th> </tr> </thead> <tbody> <tr> <td>1- Blue (A)</td> <td>+</td> <td>-</td> <td>-</td> <td>+</td> </tr> <tr> <td>2- Red (B)</td> <td>+</td> <td>+</td> <td>-</td> <td>-</td> </tr> <tr> <td>3- White (A)</td> <td>-</td> <td>+</td> <td>+</td> <td>-</td> </tr> <tr> <td>4- Yellow (B)</td> <td>-</td> <td>-</td> <td>+</td> <td>+</td> </tr> </tbody> </table> </div> </div> <p style="text-align: center;">< Damper Circuit ></p> <div style="display: flex; justify-content: space-around;"> <div data-bbox="435 965 831 1574">  <p>Check the ②, ④</p>  </div> <div data-bbox="970 949 1414 1574">  <p>Check the ①, ③ extension</p>  </div> </div> <p>Check the resistance between connectors 1,3 and 2,4 .It means check whether or not applying an electric current. If there is resistance, it means the damper not inferiority</p>	Housing No. & L/Wire Color	Step				1	2	3	4	1- Blue (A)	+	-	-	+	2- Red (B)	+	+	-	-	3- White (A)	-	+	+	-	4- Yellow (B)	-	-	+	+
Housing No. & L/Wire Color	Step																													
	1	2	3	4																										
1- Blue (A)	+	-	-	+																										
2- Red (B)	+	+	-	-																										
3- White (A)	-	+	+	-																										
4- Yellow (B)	-	-	+	+																										
<p>Standard</p>	<p>Damper</p> <table border="1" style="display: inline-table; margin-right: 20px;"> <thead> <tr> <th>Test Points</th> <th>Result</th> </tr> </thead> <tbody> <tr> <td>Red and Yellow</td> <td>373 ~ 456 ‰</td> </tr> </tbody> </table> <table border="1" style="display: inline-table;"> <thead> <tr> <th>Test Points</th> <th>Result</th> </tr> </thead> <tbody> <tr> <td>Blue and White</td> <td>373 ~ 456 ‰</td> </tr> </tbody> </table>	Test Points	Result	Red and Yellow	373 ~ 456 ‰	Test Points	Result	Blue and White	373 ~ 456 ‰																					
Test Points	Result																													
Red and Yellow	373 ~ 456 ‰																													
Test Points	Result																													
Blue and White	373 ~ 456 ‰																													

7-8. Water Valve

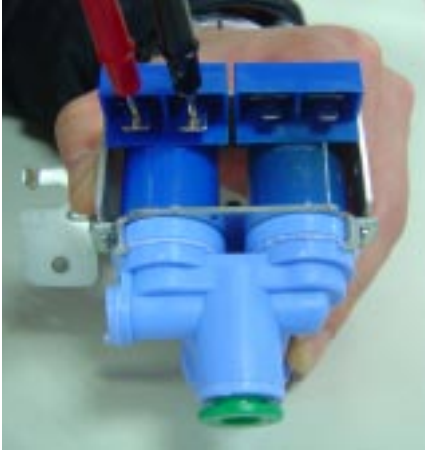
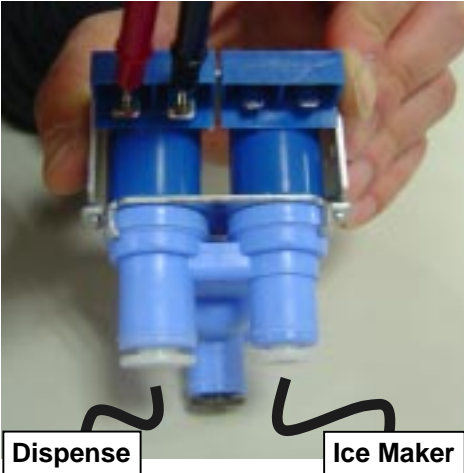
<p>Function</p>	<ul style="list-style-type: none"> - first-Water Valve (in machine room) : supply the water from city water to water filter in refrigerator - second-Water Valve (in door) : supply the water from water filter to icemaker and dispenser 				
<p>How to Measure</p>	<div style="display: flex; justify-content: space-around; align-items: flex-start;"> <div style="text-align: center;">  <p>First-water valve (in machine room)</p> </div> <div style="text-align: center;">  <p>second-water valve (in door)</p> </div> </div>				
<p>Standard</p>	<table border="1" style="margin-left: auto; margin-right: auto;"> <thead> <tr> <th>Test Points</th> <th>Result</th> </tr> </thead> <tbody> <tr> <td>(1) to (2)</td> <td>360 ~ 420 ‰</td> </tr> </tbody> </table>	Test Points	Result	(1) to (2)	360 ~ 420 ‰
Test Points	Result				
(1) to (2)	360 ~ 420 ‰				

7-9. Main PWB Assembly (EBR41956404)

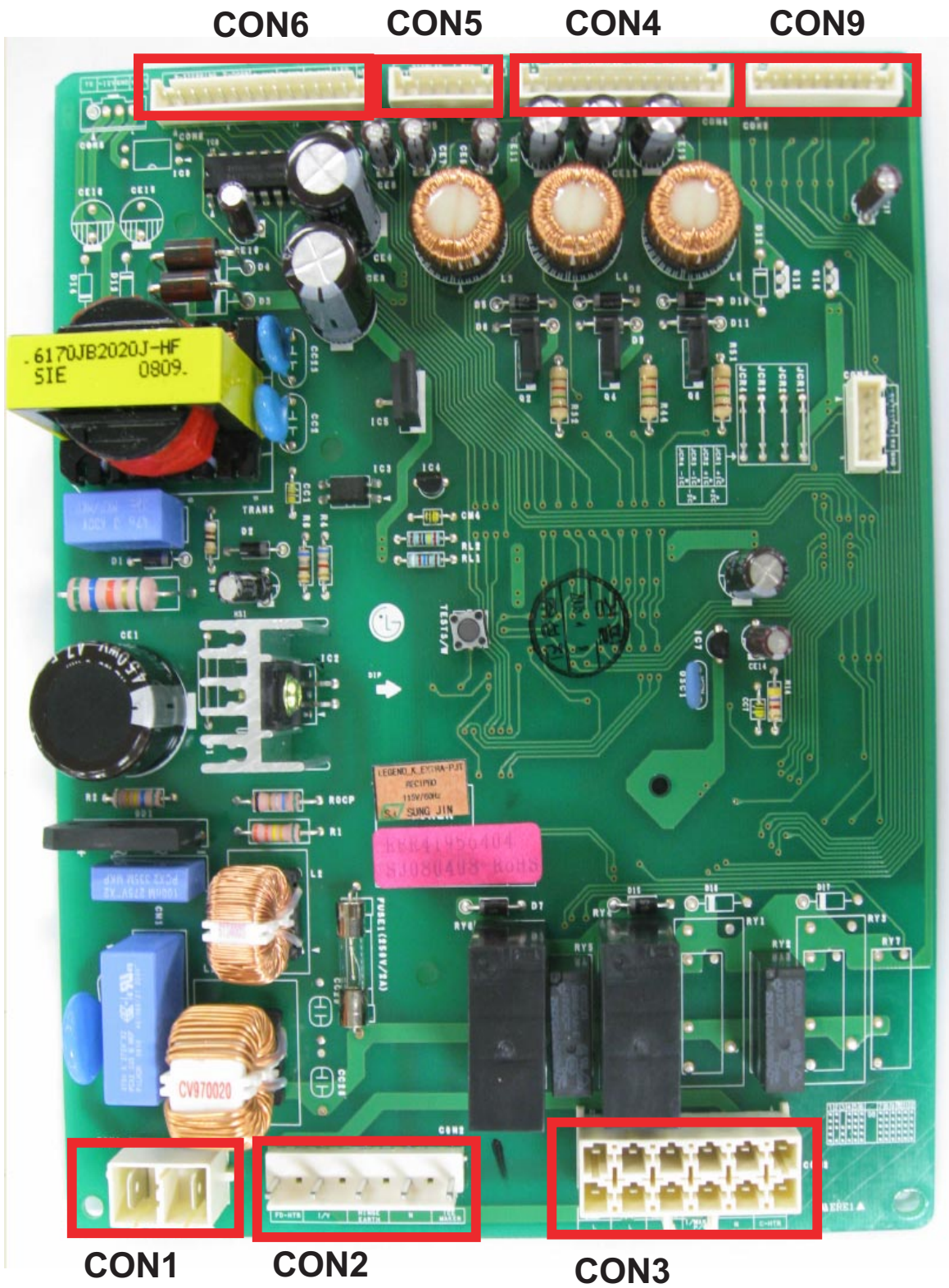

7-10. Display and Dispenser Drive PWB Assembly



CON01

Top Display PWB

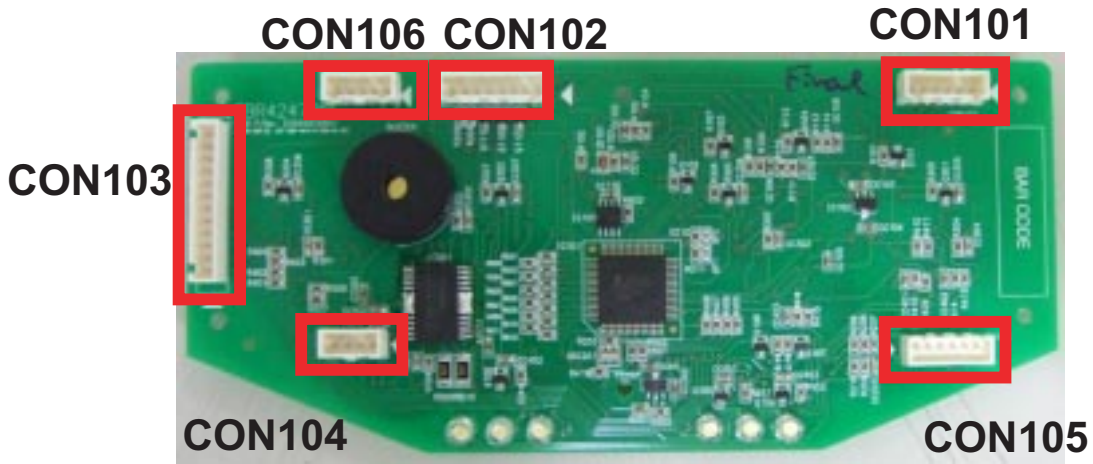

Dispenser Display PWB

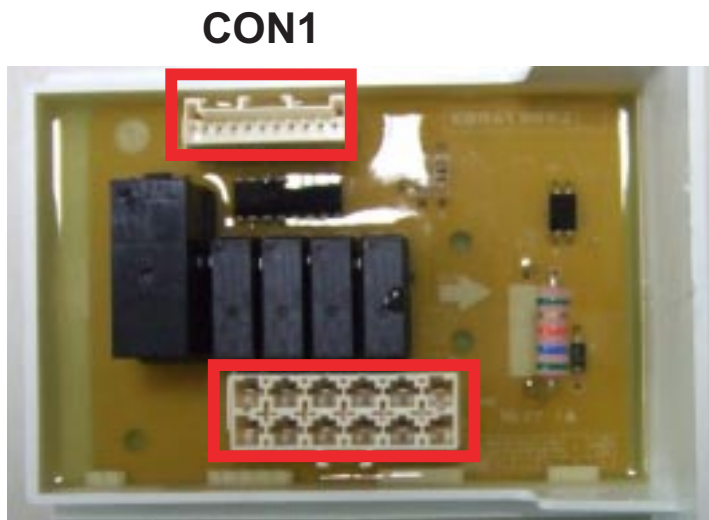

CON2
Dispenser PWB



REPAIR PARTS LIST

MODELS No.

795.78733.801
795.78739.801
795.78743.801
795.78749.801

The model number of your refrigerator is found on the serial plate inside.

All repair parts listed are available for immediate purchase or special order when you visit your nearest Sears Service Center, or the Service Department at most Sears stores. To order parts by phone, call the toll free parts number listed to the left.

When requesting service or ordering parts, always provide the following information:

f Product Type f Part Number

f Model Number f Part Description

To call Toll Free For Parts:

1-800-366-PART
(1-800-366-7278)

For Service:

1-800-4-MY-HOME
(1-800-469-4663)

Last Revision: July. 30. 2008

Sears, Roebuck and Co., Hoffman Estates, IL 60179 U.S.A.

Get it fixed, at your home or ours!

Your Home

For repair—in your home—of all major brand appliances, lawn and garden equipment, or heating and cooling systems, **no matter who made it, no matter who sold it!**

For the replacement parts, accessories and owner's manuals that you need to do-it-yourself.

For Sears professional installation of home appliances and items like garage door openers and water heaters.

1-800-4-MY-HOMESM (1-800-469-4663)

Call anytime, day or night (U.S.A. and Canada)

www.sears.com www.sears.ca

Our Home

For repair of carry-in items like vacuums, lawn equipment, and electronics, call or go on-line for the location of your nearest

Sears Parts & Repair Center.

1-800-488-1222

Call anytime, day or night (U.S.A. only)

www.sears.com

To purchase a protection agreement (U.S.A.) or maintenance agreement (Canada) on a product serviced by Sears:

1-800-827-6655 (U.S.A.)

1-800-361-6665 (Canada)

Para pedir servicio de reparación a domicilio, y para ordenar piezas:

1-888-SU-HOGARSM
(1-888-784-6427)

Au Canada pour service en français:

1-800-LE-FOYERSM
(1-888-533-6937)
www.sears.ca



® Registered Trademark /™ Trademark /SM Service Mark of Sears, Roebuck and Co.
® Marca Registrada /™ Marca de F b r i c a /SM Marca de Servicio de Sears, Roebuck and Co.
® Marque de commerce /™ Marque de p o s e de Sears, Roebuck and Co.

© Sears, Roebuck and Co.

VALVE & WATER TUBE PARTS

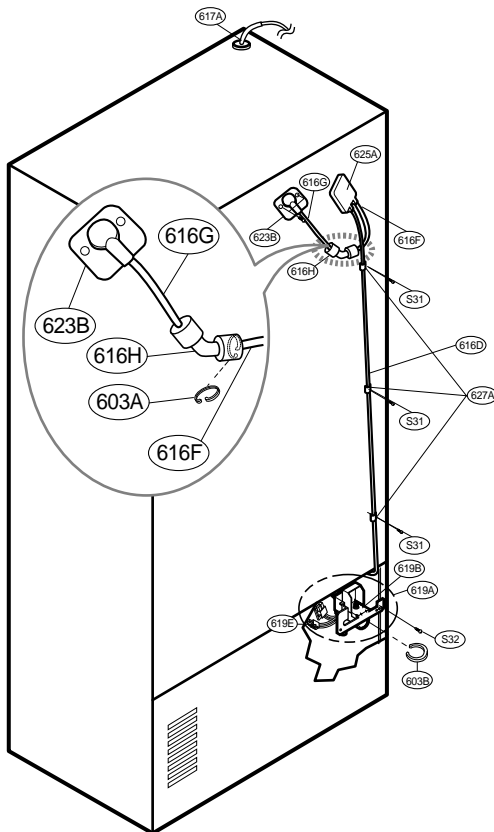

Loc no.	787***	Desc
603A	4004JA3002A	Clip
603B	4930JA3091A	Holder, Bracket
616D	5210JA3005L	Tube, Plastic
616F	5210JA3004U	Tube, Plastic
616H	4932JA3009A	Connector, Tube
617A	4970JA3004N	Spring
619A	5221JA2011J	Valve Assembly, Water
619B	5221JB2010G	Valve Assembly, Water
619E	6877JB3036V	Drawing, Assembly
623B	5006JJ2009A	Cap, Cover
625A	3550JA2184B	Cover, Tube
627A	4930JA3054A	Holder, Pipe
S31	4J00415D	Screw, Customized

CAUTION: Use the part number to order part, not the location number.

CASE PARTS

CAUTION: Use the part number to order part, not the position number.

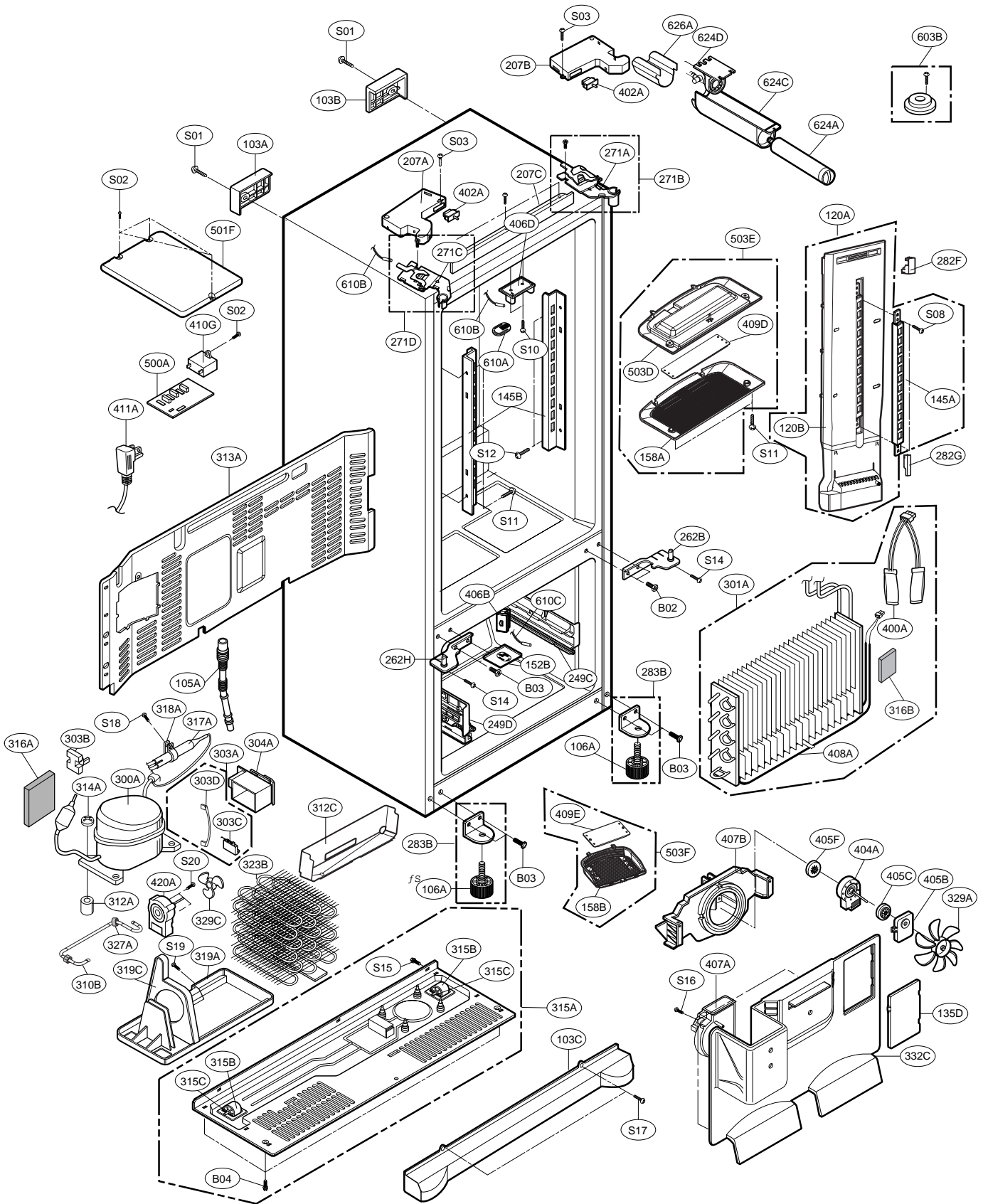

CASE PARTS

Loc No.	787*3(ST)	787*9(WB)	Des
103A	3650JA2061X	3650JA2113N	Handle, Rear
103B	3650JA2061W	3650JA2113P	Handle, Rear
103C	ACQ55957504	ACQ55957503	Cover Assembly, Lower
105A	5251JA3003D	5251JA3003D	Tube Assembly, Drain
106A	4779JJ2001B	4779JJ2001B	Leg Assembly, Adjust
120A	ADJ36702004	ADJ36702004	Duct Assembly, Multi
120B	MCZ47932702	MCZ47932702	Duct, Multi
135D	3551JJ2028A	3551JJ2028A	Cover Assembly, Grille
145A	4930JA2080C	4930JA2080C	Holder, Shelf
145B	4930JA2081C	4930JA2081C	Holder, Shelf
152B	MCK39131501	MCK39131501	Cover, Sensor
158A	MCK38019301	MCK38019301	Cover, Lamp
158B	MCK38015101	MCK38015101	Cover, Lamp
207A	3550JJ1097Q	3550JJ1097E	Cover, Hinge
207B	3550JJ1097R	3550JJ1097F	Cover, Hinge
207C	ABQ56655301	ABQ56655303	Decor Assembly, Case
249C	MEG42234402	MEG42234402	Holder, Rail
249D	MEG42234401	MEG42234401	Holder, Rail
262B	4775JJ2017P	4775JJ2017F	Hinge Assembly, Center
262H	4775JJ2017R	4775JJ2017H	Hinge Assembly, Center
271A	4775JJ2014B	4775JJ2014B	Hinge Assembly, Upper
271B	AEH60614102	AEH60614102	Hinge Assembly, Upper
271C	4775JJ2014A	4775JJ2014A	Hinge Assembly, Upper
271D	AEH60614101	AEH60614101	Hinge Assembly, Upper
283B	4774JJ3002A	4774JJ3002A	Hinge, Lower
282 F	MBL38019501	MBL38019501	Cap, Duct
282G	5006JA3111A	5006JA3111A	Cap, Duct
300A	TCA31748001	TCA31748001	Compressor,Set Assembly
301A	5421JJ1003B	5421JJ1003B	Evaporator Assembly
303A	EBG31940225	EBG31940225	Thermistor Assembly, PTC
303B	6748C-0004D	6748C-0004D	Thermistor Assembly, PTC
303C	6750C-0004R	6750C-0004R	Overload Protect
303D	6877JB2051F	6877JB2051F	Drawing, Assembly
304A	3550JA2042C	3550JA2042C	Cover, PTC
310B	4J00977P	4J00977P	Pipe, Compressor
312A	5040JA3071A	5040JA3071A	Damper, Compressor
313A	3551JJ2018A	3551JJ2018A	Cover Assembly, Machinery(Rear)
314A	4620JA3015A	4620JA3015A	Stopper, Compressor
315A	3103JJ1001H	3103JJ1001H Base	Assembly, Compressor
315B	4580JJ3001A	4580JJ3001A	Roller
315C	1PZZJA3013B	1PZZJA3013B	Pin, Common
316A	5072JA3003F	5072JA3003F	Damper, Noise
316B	5072JA3003B	5072JA3003B	Damper, Noise
317A	5851JA2008U	5851JA2008U	Drier Assembly
318A	4930JA3034A	4930JA3034A	Holder, Drier
319A	MJS37355401	MJS37355401	Tray, Drip
319C	MEA42257901	MEA42257901	Guide, Fan
323B	ACG36653801	ACG36653801	Condenser Assembly,Wire
329A	5901JA1021A	5901JA1021A	Fan Assembly
329C	ADP36665701	ADP36665701	Fan Assembly
332C	AEB34270102	AEB34270102	Grille Assembly, Fan

CAUTION: Use the part number to order part, not the position number.

CASE PARTS

LOC No.	787*3(ST)	787*9(WB)	Desc
400A	6615JB2005H	6615JB2005H	Controller Assembly
402A	6600JB3007K	6600JB3007J	Switch, Push Button
404A	4810JA2129A	4810JA2129A	Motor, DC
405B	4810JJ2005A	4810JJ2005A	Bracket, Motor
405C	5040JA2009B	5040JA2009B	Damper, Motor Support
405F	5040JA2004B	5040JA2004B	Damper, Motor Support
406B	6600JB1010K	6600JB1010K	Switch, Push Button
406D	4931JA3006A	4931JA3006A	Holder Assembly, Gasket
407A	5209JA1044A	5209JA1044A	Duct Assembly, Connector
407B	4810JJ0003A	4810JJ0003A	Bracket, Motor
408A	5300JK1005D	5300JK1005D	Heater, Sheath
409D	EAV43060804	EAV43060804	LED Assembly
409E	EAV43060803	EAV43060803	LED Assembly
410G	0CZZJB2012K	0CZZJB2012K	Capacitor, Electric Appliance Film,Box
411A	6411JB1042L	6411JB1042L	Power Cord Assembly
420A	4681JB1029D	4681JB1029D	Motor, DC
500A	6871JB1411J	6871JB1411J	PCB Assembly, MAIN
501F	3551JA2144C	3551JA2144C	Cover Assembly, PCB
503D	MBN38018601	MBN38018601	Case, Lamp
503E	ACQ33676502	ACQ33676502	Cover Assembly,Lamp
503F	ACQ33751002	ACQ33751002	Cover Assembly,Lamp
607A	4931JA3005B	4931JA3005B	Holder Assembly,Bracket
610A	3550JA2247A	3550JA2247A	Cover, Sensor
624A	5231JA2006A	5231JA2006A	Filter Assembly, Water
624C	3550JD1128B	3550JD1128B	Cover, Filter
624D	5230JA2003A	5230JA2003A	Filter, Head
626A	3550JA2279A	3550JA2279A	Cover, Filter
B01	4000W4A003A	4000W4A003A	Screw, Customized
B02	1STZJA3004G	1STZJA3004G	Screw, Customized
B03	1STZJA3004F	1STZJA3004F	Screw, Customized
B04	1BZZJA2002A	1BZZJA2002A	Bolt, Common
S01	4J00415D	4J00415D	Screw, Customized
S02	4J00415D	4J00415D	Screw, Customized
S03	4J01424B	4J01424B	Screw, Customized
S11	4J01425A	4J01425A	Screw, Customized
S14	1SZZJJ3010C	1SZZJJ3010C	Screw, Customized
S15	4000W4A003A	4000W4A003A	Screw, Customized
S16	4J00415D	4J00415D	Screw, Customized
S17	4J00415D	4J00415D	Screw, Customized
S18	4J00415D	4J00415D	Screw, Customized
S19	4J00415D	4J00415D	Screw, Customized
S20	1SZZJA3016A	1SZZJA3016A	Screw, Customized

CAUTION: Use the part number to order part, not the position number.

FREEZER PARTS

CAUTION: Use the part number to order part, not the position number.

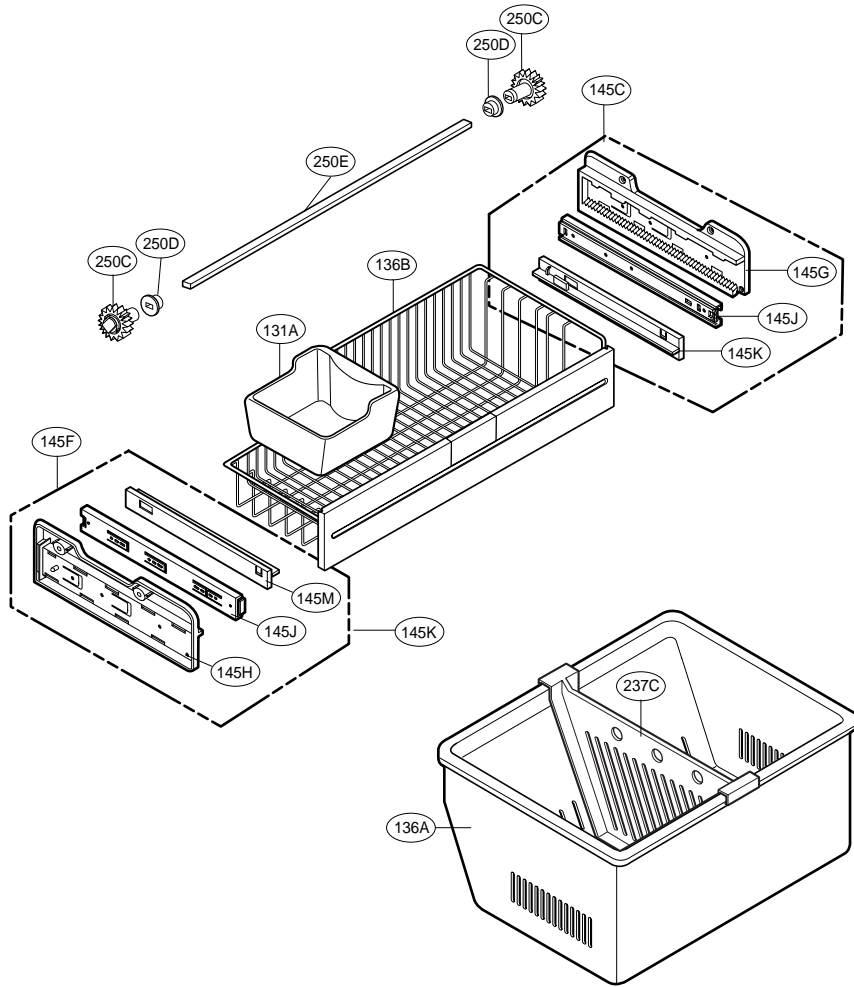

LOC No.	787*3(ST)	787*9(WB)	Description
131A	5074JA2004A	5074JA2004A	Bucket, Ice
136A	3390JJ1072A	3390JJ1072A	Tray, Drawer
136B	3391JA2054J	3391JA2054J	Tray Assembly, Drawer
145C	4975JA1040B	4975JA1040B	Guide Assembly, Rail
145F	4975JA1040A	4975JA1040A	Guide Assembly, Rail
145G	4974JA1154B	4974JA1154B	Guide, Rail
145J	5218JA1007B	5218JA1007B	Rail, Slide
145K	4932JA1010B	4932JA1010B	Connector, Rail
145M	4932JA1010A	4932JA1010A	Connector, Rail
145H	4974JA1154A	4974JA1154A	Guide, Rail
237C	4974JJ1031A	4974JJ1031A	Guide, Drawer
250C	4470JA2008A	4470JA2008A	Gear, Ice
250D	5006JA2069A	5006JA2069A	Cap, Cover
250E	MAK36519001	MAK36519001	Bar

CAUTION: Use the part number to order part, not the position number.

REFRIGERATOR PARTS

CAUTION: Use the part number to order part, not the position number.

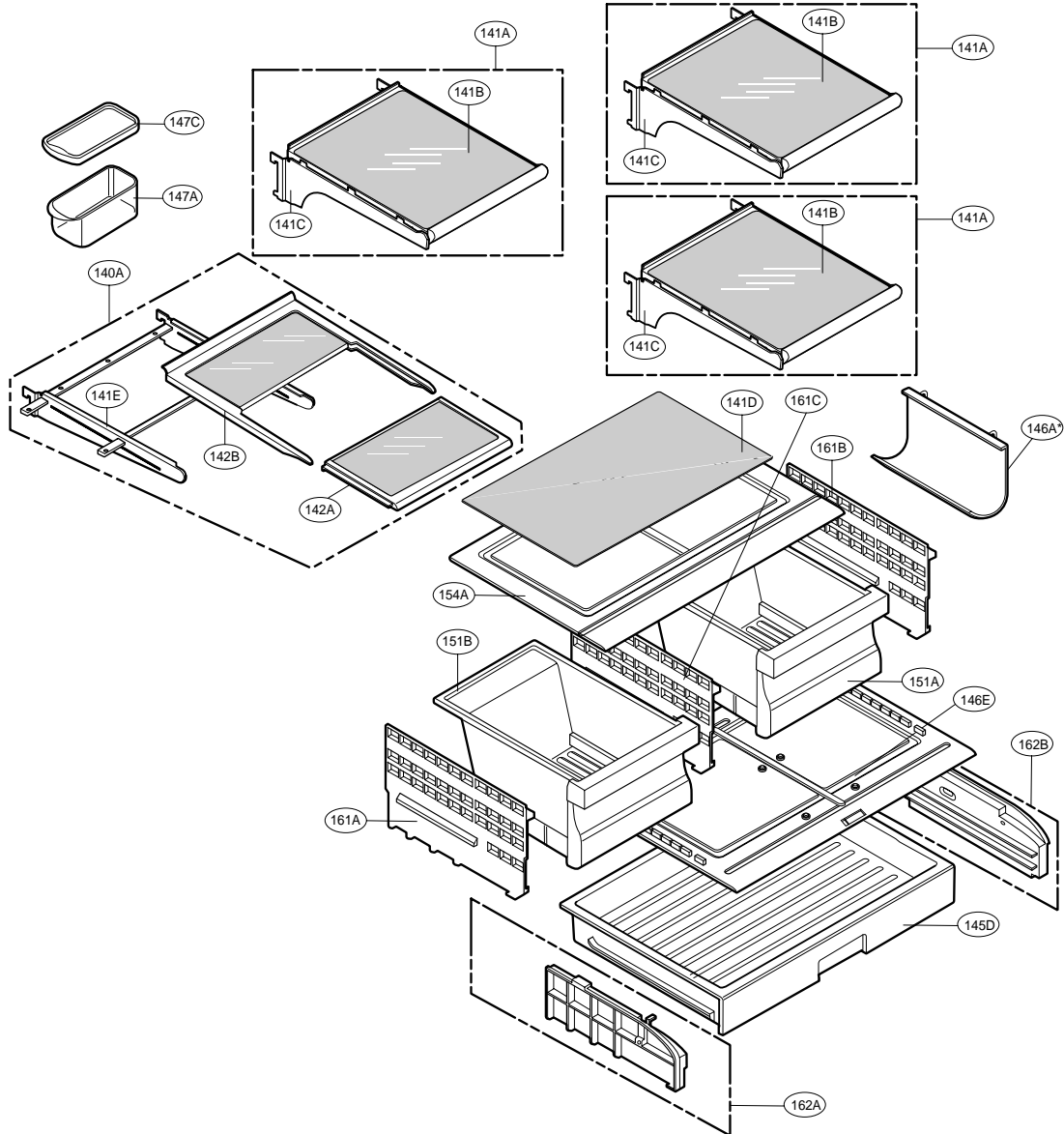

Loc No.	787*3(ST)	787*9(WB)	Desc
140A	AHT36706707	AHT36706707	Shelf Assembly, Refrigerator
141A	AHT36764303	AHT36764303	Shelf Assembly, Refrigerator
141B	MHL42265702	MHL42265702	Shelf, Refrigerator
141C	5027JJ2012F	5027JJ2012F	Shelf Assembly, Net
141D	4890JJ1007Y	4890JJ1007Y	Shelf, Glass
142A	AHT36963703	AHT36963703	Shelf Assembly, Refrigerator
142B	AHT36963801	AHT36963801	Shelf Assembly, Refrigerator
141E	5027JJ2012K	5027JJ2012K	Shelf Assembly, Net
145D	MJS42244701	MJS42244701	Tray, Fresh Room
146A	J469-00030A	J469-00030A	Rack (only 785.7874* Model)
146E	ACQ36701703	ACQ36701703	Cover Assembly, Tray
147A	5074JJ1016A	5074JJ1016A	Bucket, Dairy
147C	3550JJ1084A	3550JJ1084A	Cover, Bucket
151A	AJP36702104	AJP36702104	Tray Assembly, Vegetable
151B	AJP36702105	AJP36702105	Tray Assembly, Vegetable
154A	ACQ36701102	ACQ36701102	Cover Assembly, TV
161A	AEC36906401	AEC36906401	Guide Assembly, TV
161B	AEC36906402	AEC36906402	Guide Assembly, TV
161C	AEC36702202	AEC36702202	Guide Assembly, Rail
162A	AEC36702301	AEC36702301	Guide Assembly, Rail
162B	AEC36702302	AEC36702302	Guide Assembly, Rail

CAUTION: Use the part number to order part, not the position number.

DOOR PARTS

CAUTION: Use the part number to order part, not the position number.

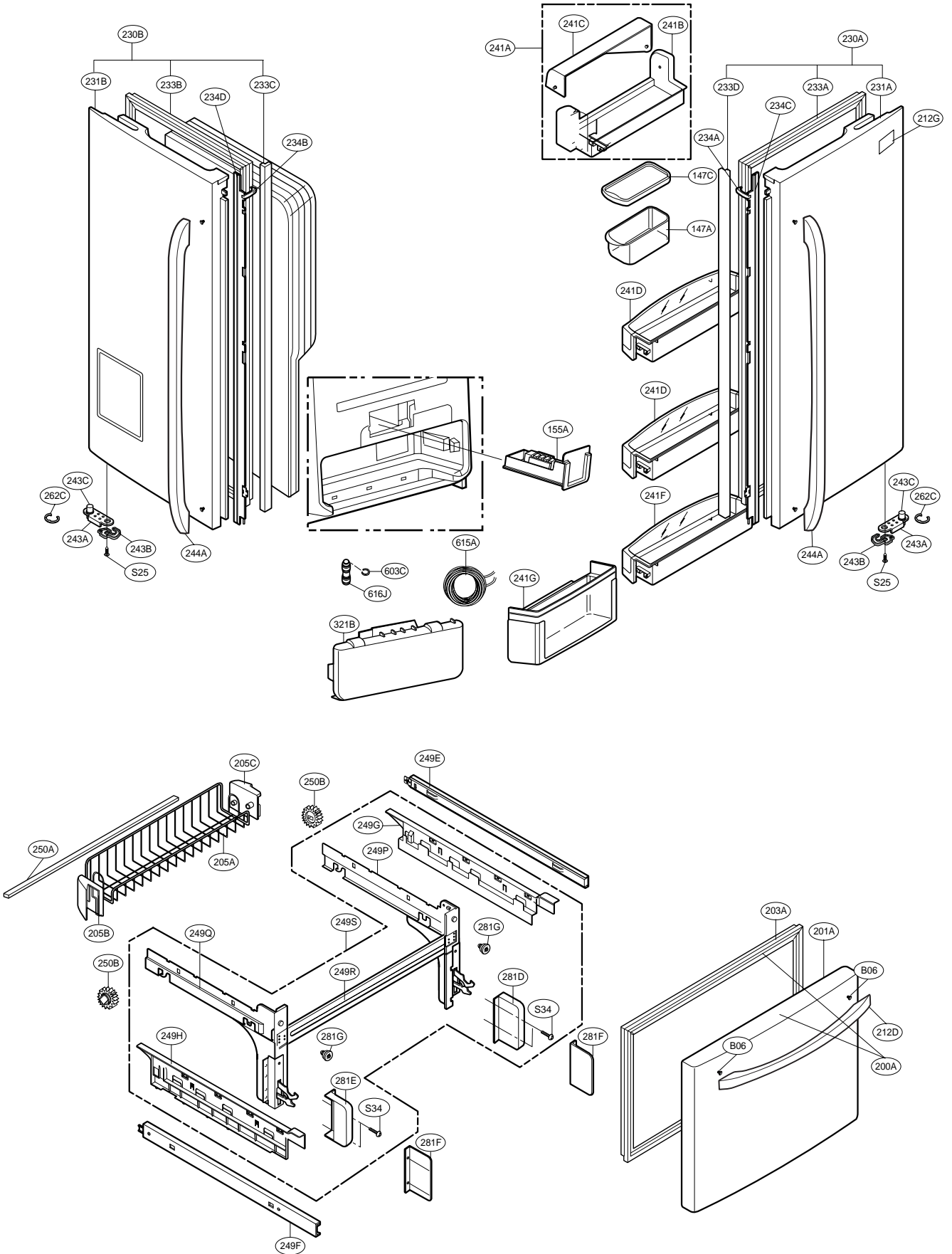

▲ Only for the service

DOOR PARTS

LOCNo.	787*3(ST)	787*9(WB)	Desc
147A	5074JJ1016A	5074JJ1016A	Bucket, Dairy
147C	3550JJ1084A	3550JJ1084A	Cover, Bucket
155A	ACQ67639201	ACQ67639201	Cover Assembly, PCB
200A	ADC57728001	ADC57728003	Door Assembly, Freezer
201A	ADD57728201	ADD57728203	Door Foam Assembly, Freezer
203A	MDS38201406	MDS38201402	Gasket, Door
205A	5004JJ1061B	5004JJ1061B	Basket, Door
205B	5004JA2017A	5004JA2017A	Basket, Tilt
205C	5004JA2017B	5004JA2017B	Basket, Tilt
212D	AED37133201	AED37133202	Handle Assembly, Freezer
212G	3846JD1019B	3846JD1019B	Name Plate
230A	ADC57728301	ADC57728303	Door Assembly, Refrigerator(Right)
230B	ADC68388101	ADC68388102	Door Assembly, Refrigerator(Left)
231A	ADD57728501	ADD57728503	Door Foam Assembly, Refrigerator
231B	ADD68388001	ADD68388002	Door Foam Assembly, Refrigerator
233A	4987JJ2002E	4987JJ2002C	Gasket Assembly, Door
233B	4987JJ2002F	4987JJ2002D	Gasket Assembly, Door
233C	3551JJ2030B	3551JJ2030B	Cover Assembly, Front
233D	3551JJ2030A	3551JJ2030A	Cover Assembly, Front
234A	4430JJ2004A	4430JJ2004A	Cam, Shaft
234B	4430JJ2004B	4430JJ2004B	Cam, Shaft
234C	4931JJ2002E	4931JJ2002C	Holder Assembly, Gasket
234D	4931JJ2002F	4931JJ2002D	Holder Assembly, Gasket
241A	AAP33686303	AAP33686303	Basket Assembly, Door
241B	MAN38142901	MAN38142901	Basket, Door
241C	MAN39723202	MAN39723202	Basket, Window
241D	AAP36817401	AAP36817401	Basket Assembly, Door
241F	AAP36817601	AAP36817601	Basket Assembly, Door
241G	AAP33726606	AAP33726606	Basket Assembly, Door
243A	4620JJ3006D	4620JJ3006C	Stopper, Door
243B	4620JJ2009A	4620JJ2009A	Stopper, Door
243C	J326-00012A	J326-00012A	Bush
244A	AED37083001	AED37083002	Handle Assembly, Refrigerator
249E	5218JA1010E	5218JA1010E	Rail, Slide
249F	5218JA1010F	5218JA1010F	Rail, Slide
249G	3550JA1455C	3550JA1455C	Cover, Connector
249P	5218JA1007B	5218JA1007B	Rail, Slide
249H	3550JA1455D	3550JA1455D	Cover, Connector
249Q	ACJ36625807	ACJ36625807	Connector Assembly
249R	4932JJ2009B	4932JJ2009B	Connector, Tilt
249S	ACJ36695103	ACJ36695103	Connector Assembly
250A	MAK39123901	MAK39123901	Bar
250B	4403JA3005A	4403JA3005A	Connector Assembly
262C	4350JA3005B	4350JA3005B	Ring
281D	3550JA2267B	3550JA2267B	Cover, Hinge
281F	3550JA2264A	3550JA2264A	Cover, Hinge
281G	MCQ42969201	MCQ42969201	Damper, Pipe
321B	MCK42342101	MCK42342101	Cover, Front
603C	4004JA3002A	4004JA3002A	Clip
615A	4838JA2003D	4838JA2003D	Tank, Water
616J	4932JA3002E	4932JA3002E	Connector, Tube
S25	1SZZJA3011D	1SZZJA3011D	Screw, Customized
S34	4J01425A	4J01425A	Screw, Customized

CAUTION: Use the part number to order part, not the position number.

DISPENSER PARTS

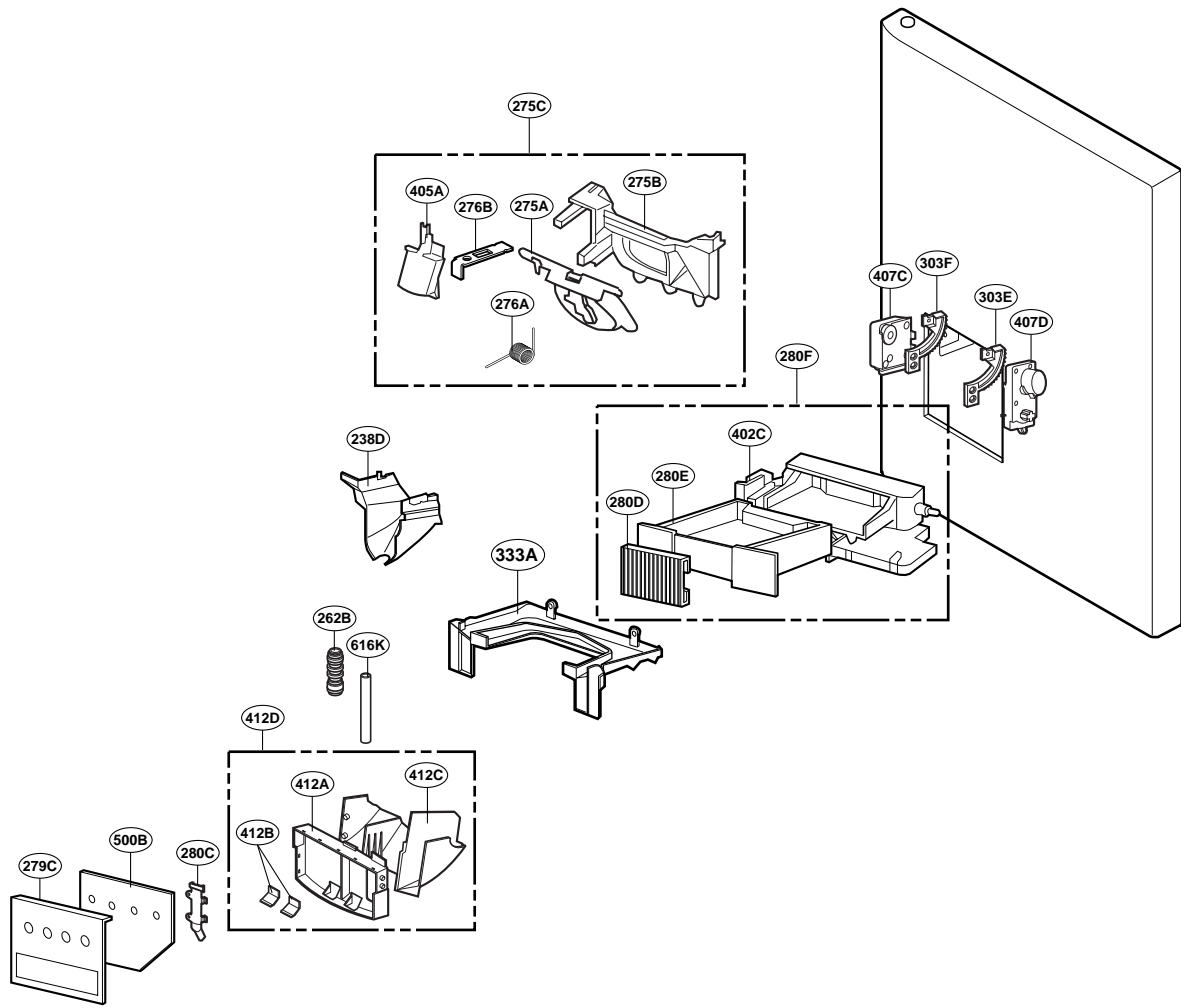

LOCNo.	787*3(ST)	787*9(WB)	Desc
238D	MDR47984501	MDR47984501	Funnel
262B	MCD56869401	MCD56869401	Connector, Tube
275A	5007JA3006X	5007JA3006X	Cap Assembly, Duct
275B	MCK47984401	MCK47984401	Cover, Duct
275C	ADJ55724401	ADJ55724401	Duct Assembly, Insulation
276A	4970JA3011C	4970JA3011C	Spring, Lever
276B	4930JA3043A	4930JA3043A	Holder, Lever
279C	ACQ67140901	ACQ67140903	Cover Assembly, Display
280C	MCK47995301	MCK47995301	Cover, Tube
280D	MBL47986201	MBL47986201	Cap, Rubber
280E	MJS47985001	MJS47985001	Tray, Dispenser
280F	AJP55724302	AJP55724302	Tray Assembly, Ice
303E	MDT47982101	MDT47982101	Gear Arm, Right
303F	MDT47982102	MDT47982102	Gear Arm, Left
333A	MJS47981901	MJS47981901	Trough, Drip
405A	6421JB2002D	6421JB2002D	Solenoid Reversing Valve
407D	ACQ55724502	ACQ55724502	Cover Assembly, Motor
407C	ACQ55724602	ACQ55724602	Cover Assembly, Sensor
412A	MBN47982202	MBN47982202	Case, PCB
412B	MCK47982301	MCK47982301	Cover, LED
412C	ABQ55724702	ABQ55724702	Case Assembly, PCB
402C	6600JB3001F	6600JB3001F	Switch, Micro
500B	EBR42479501	EBR42479501	PCB Assembly, Display
616K	5210JA3030N	5210JA3030N	Tube, Plastic

ICE MAKER & ICE BANK PARTS

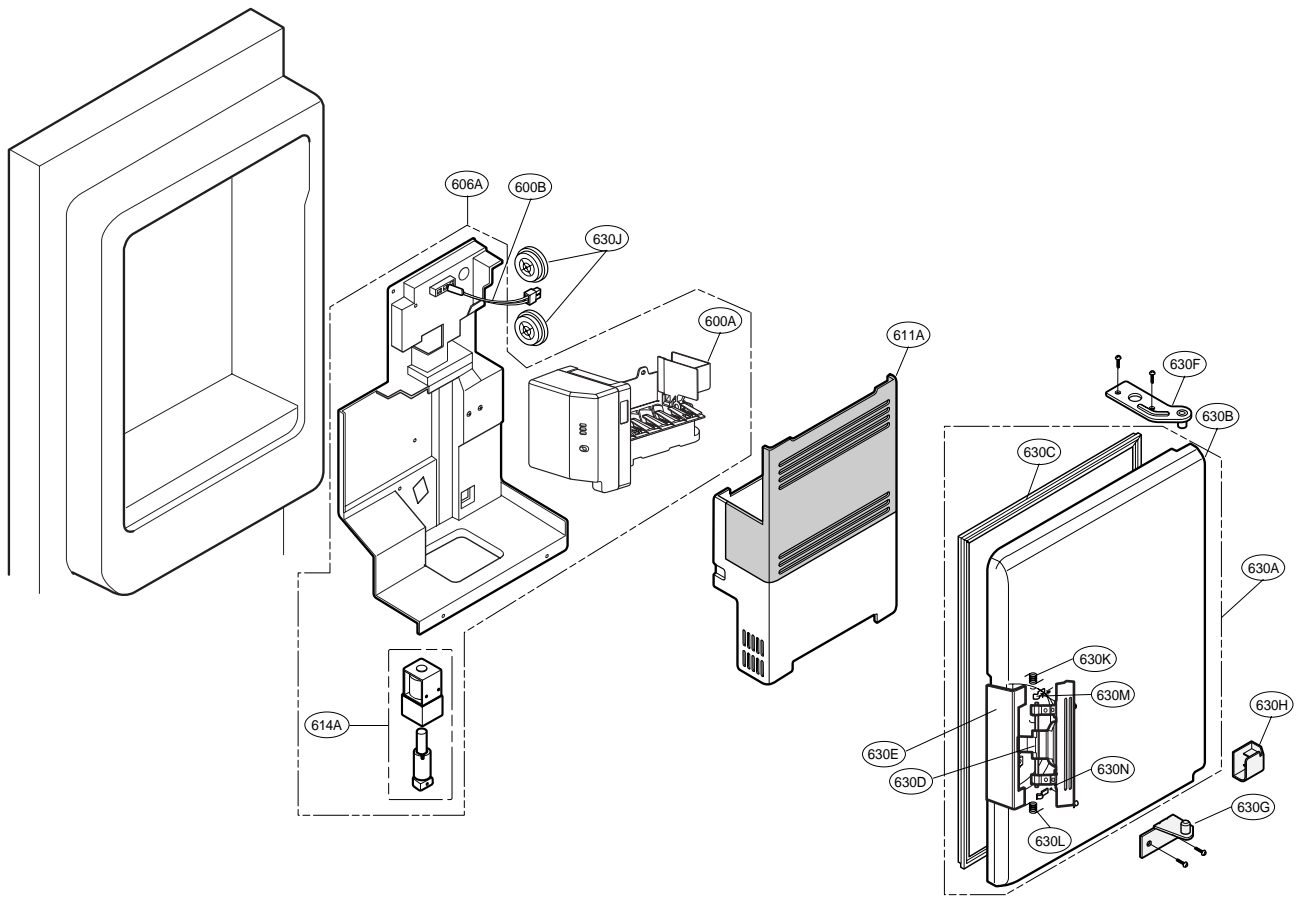

LOCNo.	787*3(ST)	787*9(WB)	Desc
600A	AEQ36756901	AEQ36756901	Ice Maker Assembly, Kit
600B	6500JB1008A	6500JB1008A	Sensor, Temperature
606A	4681JA1006D	4681JA1006D	Motor, AC
611A	5075JA1044J	5075JA1044J	Bucket Assembly, Ice
614A	6421JA3001N	6421JA3001N	Solenoid Assembly
630A	ADC33751102	ADC33751102	Door Assembly, Freeze Room
630B	ADD33178702	ADD33178702	Door Foam Assembly
630C	4987JA2012B	4987JA2012B	Gasket Assembly, Door
630D	MEB49049002	MEB49049002	Handle, Home Bar
630E	MCR42600501	MCR42600501	Decor, Handle
630F	4775JA2101A	4775JA2101A	Hinge Assembly, Upper
630G	4775JA2102A	4775JA2102A	Hinge Assembly, Lower
630H	MCK38202501	MCK38202501	Cover, Home Bar
630K	4970JA3044A	4970JA3044A	Spring
630L	4970JA3045A	4970JA3045A	Spring
630M	4860JA3010B	4860JA3010B	Clamp
630N	4860JA3010A	4860JA3010A	Clamp