

This Owner's Manual is provided and hosted by [Appliance Factory Parts](#).

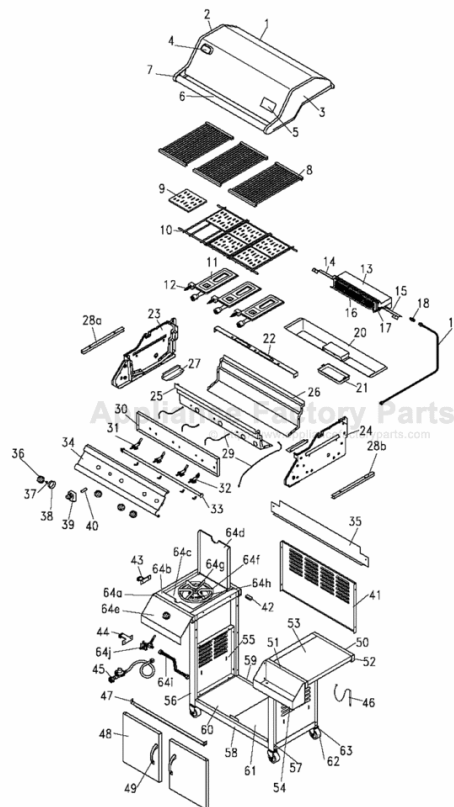

Bakers and Chefs Y0005XC-1 Owner's Manual

[Shop genuine replacement parts for Bakers and Chefs
Y0005XC-1](#)



[Find Your Bakers and Chefs Grill Parts - Select From 17 Models](#)

----- Manual continues below -----

BAKERS



& CHEFS

ASSEMBLY & OPERATING INSTRUCTIONS

TABLE OF CONTENTS	PAGE
SAFETY INSTRUCTIONS	2
PARTS LIST	5
ASSEMBLY INSTRUCTIONS	8
LIGHTING & OPERATING INSTRUCTIONS	12
CLEANING & MAINTENANCE INSTRUCTIONS	13
FREQUENTLY ASKED QUESTIONS	15
INTRODUCTION TO COOKING METHODS	17
BAKERS & CHEFS RECIPES	27

MODEL
Y0005XC-1
LPG

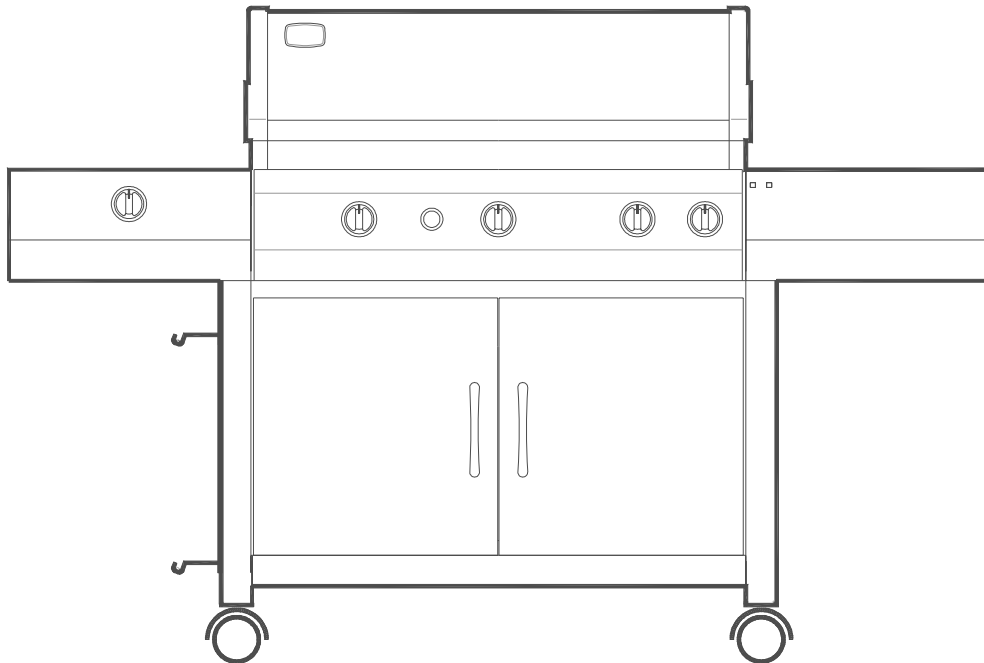

READ THE FOLLOWING INSTRUCTIONS CAREFULLY AND BE SURE YOUR GRILL IS PROPERLY INSTALLED, ASSEMBLED AND MAINTAINED. FAILURE TO FOLLOW THESE INSTRUCTIONS MAY RESULT IN SERIOUS BODILY INJURY AND/OR PROPERTY DAMAGE. IF YOU HAVE QUESTIONS CONCERNING ASSEMBLY OR OPERATION, CALL OUR SERVICE CENTER AT 1-800-770-9769, MONDAY THROUGH FRIDAY 8:00 AM - 4:30 PM, CST.

NOTE TO INSTALLER:

LEAVE THESE INSTRUCTIONS WITH THE CONSUMER AFTER INSTALLATION.

NOTE TO CONSUMER: RETAIN FOR FUTURE REFERENCE.

THIS OUTDOOR COOKING GAS APPLIANCE IS NOT INTENDED TO BE INSTALLED IN OR ON RECREATIONAL VEHICLES AND/OR BOATS.

Read carefully before assembling and operating your Gas Grill.

INSTALLATION

This gas grill must be installed in accordance with the local codes or, if in an area without local codes, with the latest edition of the National Fuel Gas Code ANSI Z223.1. In Canada, installation must conform to the standard CAN/CGA 1-b149.1 and/or .2 (Installation Code for Gas Burning Appliances and Equipment) and any local codes.

THE LOCATION FOR YOUR GRILL

DO NOT use your gas grill in garages, porches, breezeways, sheds or other enclosed areas. Your gas grill is to be used OUTDOORS ONLY, at least 21" from the back and side to any combustible surface. The grill should not be placed under any surface that will burn. Do not obstruct the flow of combustion and ventilation air around the grill housing.

This outdoor cooking gas appliance is not intended to be installed in or on recreational vehicles and/or boats.

FOR YOUR SAFETY

If you smell gas:

1. Shut off gas to the appliance.
2. Extinguish any open flame.
3. Open lid.
4. If odor continues, immediately call your gas supplier or your fire department.

FOR YOUR SAFETY

1. Do not store or use gasoline or other flammable vapors and liquids in the vicinity of this or any other appliance.
2. An LP cylinder not connected for use shall not be stored in the vicinity of this or any other appliance.

(a) Do not store (empty or full) spare gas cylinders under or near this or any other appliance.

(b) Never fill the cylinder beyond 80 percent full.

If the information in "(a)" and "(b)" is not followed exactly, a fire causing death or serious injury may occur.

Keep the gas fuel hose away from hot grill surfaces and dripping grease. Avoid unnecessary twisting of hose. Visually inspect hose prior to each use for cuts, cracks, excessive wear or other damage.

If damaged - do not use the grill. Contact your dealer for a factory authorized replacement hose.

NEVER light grill with lid closed or before checking to insure burner tubes are fully seated over gas valve orifices.

NEVER lean over cooking surface while lighting grill. Use barbecue tools with long wooden handles and good quality insulated oven mitts when operating grill.

PROTECT YOUR CHILDREN: Keep them away from a hot grill during and after cooking. Do not allow children to play near or operate grill.

CHECKING FOR GAS LEAKS

NEVER TEST FOR LEAKS WITH A FLAME

Prior to first use and at the beginning of each new season (or whenever LP gas cylinder is changed), you must check for gas leaks. Follow these steps:

1. Make soap solution by mixing one part liquid detergent and one part water.
2. Turn off heat control valve(s), then turn on gas at source.
3. Apply the soap solution to all gas connections. Bubbles will appear in the soap solution if connections are not properly sealed. Tighten or repair as necessary.
4. If you have a gas leak that you cannot repair, turn off the gas at the source, disconnect fuel line from grill and immediately call your grill dealer or gas supplier for professional assistance.

LP GAS CYLINDER SAFETY

Your gas grill is designed for use with a standard 20 lb. LP gas cylinder (not included). DO NOT CONNECT YOUR GRILL TO AN LP GAS CYLINDER EXCEEDING THIS CAPACITY. A tank of approximately 12 inches in diameter by 18-1/2 inches high should be the Maximum size tank used. We recommend buying an "OPD" gas cylinder - which offers an Overfilling Prevention Device. This safety feature prevents the tank from being accidentally overfilled which can cause malfunction with your cylinder, regulator and/or grill. Also be sure that (1) the cylinder is provided with a shutoff valve terminating in an LP gas supply cylinder valve outlet compatible with a Type I cylinder connection device and a safety relief device having a direct communication with the vapor space of the cylinder; (2) the cylinder supply system must be arranged for vapor withdrawal; and (3) the cylinder used must include a collar to protect the cylinder valve.

The LP gas cylinder must be constructed and marked in accordance with specifications of the U.S. Department of Transportation (DOT). In Canada, gas cylinders must meet Canadian Transportation and Communications(CTC) specifications.

DANGER: If you smell or hear the hiss of escaping gas from the LP gas cylinder:

- > **Get away from the LP gas cylinder.**
- > **Do not attempt to correct the problem yourself.**
- > **Call your fire department (Do not make the call from near the LP gas cylinder - your telephone is an electrical device).**

Never connect an unregulated LP gas cylinder to your grill. A gas regulator adjusted to have an outlet pressure of 11" water column (W.C.) is supplied for connection to the LP gas cylinder. The pressure regulator and hose assembly supplied with the appliance must be used. Replacement pressure regulators and hose assemblies must be those specified by the appliance manufacturer.

Have the LP gas cylinder filled by a reputable LP gas dealer, and visually inspected and re-qualified at each filling.

Have your LP gas dealer check the release valve after every filling to assure that it remains free of defects.

Always keep cylinder in an upright position. Always close the cylinder valve when the grill is not in use.

Do not subject LP gas cylinder to excessive heat.

Never store your LP gas cylinder indoors. If you store your grill indoors, ALWAYS disconnect LP gas cylinder FIRST, and store LP gas cylinder safely outside.

When the appliance is not in use, the gas must be turned off at the supply cylinder.

Storage of an appliance indoors is permissible only if the cylinder is disconnected and removed from the appliance.

Cylinders must be stored outdoors in a well-ventilated area out of the reach of children. Disconnected cylinders must not be stored in a building, garage or any other enclosed area.

HOSE ASSEMBLY SAFETY

The hose assembly must be inspected before each use of the appliance. If it is evident there is excessive abrasion or wear; or the hose is cut, it must be replaced prior to the appliance being put into operation.

TO CONNECT THE LP GAS SUPPLY CYLINDER, PLEASE FOLLOW THESE STEPS:

1. Make sure tank valve is in its full off position. (Turn clockwise to stop)

2. Check tank valve features to ensure it has proper external mating threads. (Type 1 connection per 10-94 AGA Requirement)
3. Make sure all burner valves are in their off position.
4. Inspect valve connections port and regulator assembly. Look for any damage or debris. Remove any debris. Inspect hose for damage. Never attempt to use damaged or plugged equipment. See your local LP gas dealer for repair.
5. When connecting regulator assembly to the tank valve, hand tighten nut clockwise to a positive stop. Do Not use a wrench to tighten. Use of a wrench may damage quick coupling nut and result in a hazardous condition.
6. Open tank valve fully (counter-clockwise). Use a soapy water solution to check all connections for leaks before attempting to light grill. If a leak is found, turn tank valve off and do not use grill until repairs can be made by a local LP gas dealer.

To disconnect LP gas cylinder:

- a) Turn the burner valve off.
- b) Turn the tank valve off fully. (Turn clockwise to stop.)
- c) Detach the regulator assembly from tank valve by turning the quick coupling nut counter-clockwise.

SAFETY !

BEWARE OF SPIDERS



CAUTION: BURNER TUBES MUST BE INSPECTED AND CLEANED BEFORE FIRST USE

Spiders and small insects occasionally spin webs or make nests in the burner tubes during warehousing and transit. These webs can lead to a gas flow obstruction which could result in a fire in and around the burner tubes. This type of fire is known as "FLASH-BACK" and can cause serious damage to your grill and create an unsafe operating condition for the user. Although an obstructed burner tube is not the only cause of "FLASH-BACK" it is the most common cause and frequent inspection and cleaning of the burner tubes is necessary.

SAFETY !

CARE AND MAINTENANCE

As with all appliances, proper care and maintenance will keep them in top operating condition and prolong their life. Your new gas grill is no exception. By following these cleaning procedures on a timely basis, your grill will be kept clean and working properly with minimum effort.

FOLLOW THE BURNER AND BURNER TUBE CLEANING PROCEDURE BEFORE ASSEMBLY OF YOUR GRILL.

To reduce the chance of "Flash-back", the procedure below should be followed at least once a month in late summer or early fall when spiders are most active, or when your grill has not been used for an extended period of time.

BURNER TUBE CLEANING

For cleaning the burner tubes. Follow the procedure that is most convenient for you.

1. Remove burner assembly from the grill bowl. Bend a stiff wire, (a light weight coat hanger works well) into a small hook as shown below,



Run the hook up through each venturi tube and into the burner several times.

2. Use a bottle brush with a flexible handle. Run the brush up through each venturi tube and into the burner several times.

BURNER CLEANING

Regardless of which venturi cleaning procedure you used, we recommend that you complete the following steps to help prolong burner life.

1. Wire brush entire outer surface of burner to remove loose corrosion.
2. Clean any clogged holes with a stiff wire (for example: an open paper clip).
3. Inspect the burner assembly for any opening caused by corrosion.
4. If openings due to corrosion are found, order a new burner.
5. Replace the burner and cotter pin as described in the assembly instructions.
6. Check the burner for proper location after replacing.
Check to assure the valve orifices are inside of the burner tubes.
- 7.

Should "Flash-back" occur, immediately turn the control knobs to "OFF" and carefully turn the gas supply off at the gas source.

VERY IMPORTANT:

The location of burner with respect to orifice is vital for safe operation. Check to assure the valve orifices are inside of the burner tubes before using your gas grill. See drawing below.

If the burner tubes (venturi) do not fit over the valve orifices, lighting the burners may cause explosion and/or fire.

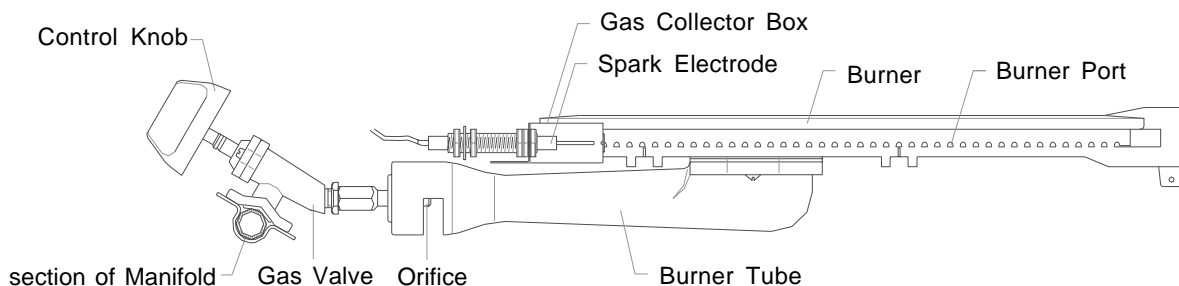

Y0005XC-1 Parts

List Remove all components from cartons and place within easy reach. Turn the largest carton upside down and it will provide a comfortable height work surface for grill assembly.

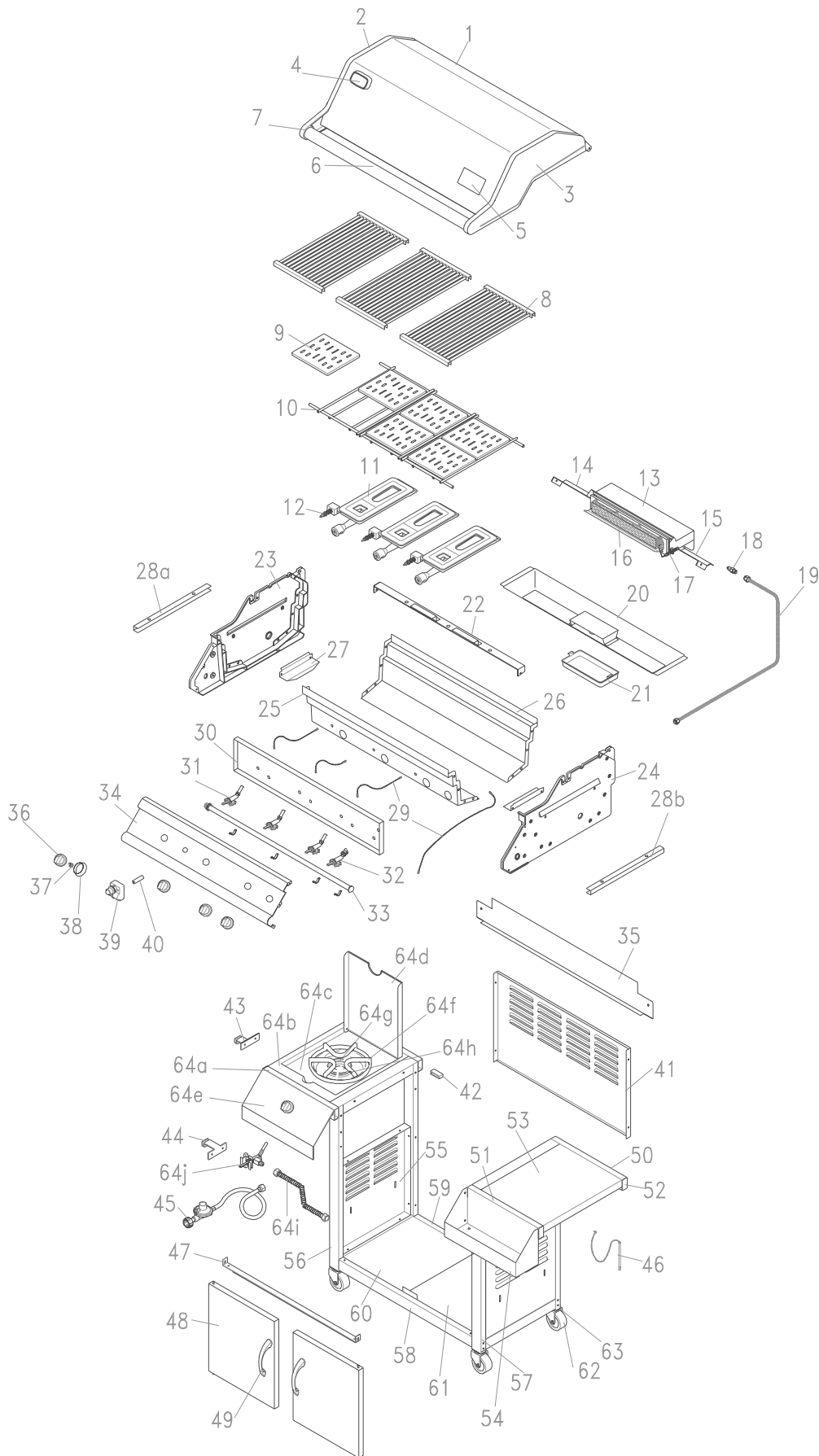

REF#	DESCRIPTION	PART#	QTY.	REF#	DESCRIPTION	PART#	QTY.
1.	Lid Plate	P0129C	1	59.	Bottom Shelf Bracket, rear	P1034G	1
2.	Lid Side Panel, left	P0147C	1	60.	Bottom Shelf, left	P1034J	1
3.	Lid Side Panel, right	P0146C	1	61.	Bottom Shelf, right	P1034K	1
4.	Heat Indicator	P0615E	1	62.	Castor	P5115A	4
5.	Name Plate	P0435A	1	63.	Castor Seat	P4524A	4
6.	Lid Handle	P0234A	1	64a.	Side Burner Bracket	P1207D	1
7.	Heat-Insulating Spacer	P5573A	2	64b.	Side Burner Frame	P1145A	1
8.	Cooking Grid	P1650A	3	64c.	Side Burner Body	P2327A	1
9.	Ceramic Flame Tamer	P1736A	6	64d.	Side Burner Lid	P1144A	1
10.	Rack for Flame Tamer	P1736B	1	64e.	Side Burner Control Panel	P2963A	1
11.	Burner	P02001067E	3	64f.	Pot Support	P80E4A	1
12.	Gas Collector Box W. Electrode	P2623B	3	64g.	Side Burner	P1922A	1
13.	Cover for Back Burner	P8085A	1	64h.	Spark Electrode for Side Burner	P2632B	1
14.	Wind Shield, left	P8086B	1	64i.	Connection Tube	P39A5A	1
15.	Wind Shield, right	P8086A	1	64j.	Gas Valve for Side Burner	P32B3A	1
16.	Back Burner	P1934A	1		Owner's Manual	P4792A	1
17.	Spark Electrode	P2624B	1		Hardware Pack (contents page 7)	P55C5A	1
18.	Orifice	P5643A	1				
19.	Gas Tube Assembly	P3512A	1				
20.	Grease Draining Tray	P2726A	1				
21.	Grease Receptacle	P2717A	1				
22.	Burner Bracket	P2219A	1				
23.	Bowl Side Panel, left	P0730C	1				
24.	Bowl Side Panel, right	P0729C	1				
25.	Bowl Front Panel	P0733A	1				
26.	Bowl Rear Panel	P0734A	1				
27.	Grease Shield	P55C4A	2				
28a.	Cover for Gas Tube, left	P8084C	1				
28b.	Cover for Gas Tube, right	P8084D	1				
29.	Electric Wire Set	P2632A	1				
30.	Heat Shield for Control Panel	P2943B	1				
31.	Gas Valve for Main Burner	P3229Z	3				
32.	Gas Valve for Back Burner	P32A9C	1				
33.	Gas Manifold	P5029A	1				
34.	Control Panel	P2964A	1				
35.	Rear Wind Shield	P8089B	1				
36.	Control Knob	P3409B	5				
37.	Spring	P80E3A	5				
38.	Control Knob Seat	P3429C	5				
39.	Electric Ignitor	P2503E	1				
40.	AA Battery	P8080A	1				
41.	Rear Panel	P4317C	1				
42.	U-shape Insert	P5574A	4				
43.	Tank Hook	P4031A	1				
44.	Tank Holder	P4023D	1				
45.	Regulator W. Hose	P3632D	1				
46.	Lighting Stick	P5540A	1				
47.	Door Bracket	P4407C	1				
48.	Door Panel	P4337A	2				
49.	Door Handle	P0247A	2				
50.	Side Shelf Bracket, rear	P1207B	2				
51.	Side Shelf Bracket for Spice	P1207C	1				
52.	Tray	P4517A	4				
53.	Cap for Side Shelf Bracket	P1133B	1				
54.	Side Shelf	P5212A	1				
55.	Spice Tray	P4318B	2				
56.	Side Panel	P0842A	1				
57.	Cart Legs, left	P0842B	1				
58.	Cart Legs, right	P1034H	1				
	Bottom Shelf Bracket, front						

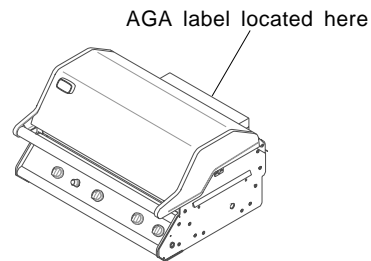

HOW TO ORDER REPLACEMENT PARTS AND ACCESSORIES:

Call our service center at 1-800-770-9769, Monday through Friday 8:00 am - 4:30 pm, CST.

To make sure you obtain the correct replacement part(s) for your Baker's & Chef Gas Grill, please refer to the parts list on this page. The following information is required to assure getting the correct part:

1. Gas Grill Model Number (see AGA sticker on grill)
2. Part Number
3. Description
4. Quantity of parts needed

Please allow sufficient time to process and ship.

IMPORTANT: Keep this assembly and operating instruction manual for convenient referral and for part replacement.

IMPORTANT: Use only factory authorized parts. The use of any part that is not factory authorized can be dangerous. This will also void your warranty.

The following table illustrates a breakdown of the screwpack. It highlights what components are used in the various stages of assembly.

REF.	COMPONENTS	USES
B.	X8 1/4" x 2 1/2" PHILLIPS HEAD SCREW	ASSEMBLES 2 BOTTOM SHELF BRACKETS TO THE CART LEGS
N. L.	X4 1/4" x 3/4" PHILLIPS HEAD SCREW X4 1/4" LOCK NUT	SECURES GRILL BOWL ONTO THE CART
B. L.	X2 1/4" x 2 1/2" PHILLIPS HEAD SCREW X2 1/4" LOCK NUT	ATTACHES TANK HOLDER TO THE CROSS BRACE OF LEFT-SIDE CART LEGS
E. L.	X2 1/4" x 1/2" PHILLIPS HEAD SCREW X2 1/4" LOCK NUT	SECURES TANK HOOK TO THE SIDE PANEL
G.	X4 3/16" x 3/4" PHILLIPS HEAD SCREW	SECURES REAR PANEL TO THE CART
P.	X4 PLAIN WASHER	FOR CASTOR INSTALLATION
E.	X2 1/4" x 1/2" PHILLIPS HEAD SCREW	ATTACHES DOOR BRACKET TO THE CART
C. L.	X8 1/4" x 2 1/4" SQUARE BOLT X8 1/4" LOCK NUT	ATTACHES SIDE SHELF AND SIDE BURNER TO THE CART LEGS
Q.	X4 M5 x 6mm PHILLIPS HEAD SCREW <i>(ALREADY SCREWED INTO DOOR HANDLES)</i>	INSTALLS THE HANDLES ONTO THE DOORS
K.	X2 3/16" x 1/2" PHILLIPS HEAD SCREW	SECURES REAR WIND SHIELD TO THE BACK OF GRILL CART.
R.	X2 3/16" x 3/8" PHILLIPS HEAD STAINLESS STEEL SCREW	INSTALLS THE SPICE TRAY TO SIDE SHELF
S. T.	X2 3/16" x 3/8" HEX HEAD SCREW X2 PLAIN WASHER	INSTALLS THE CONTROL PANEL TO SIDE BURNER

Actual Sizes:

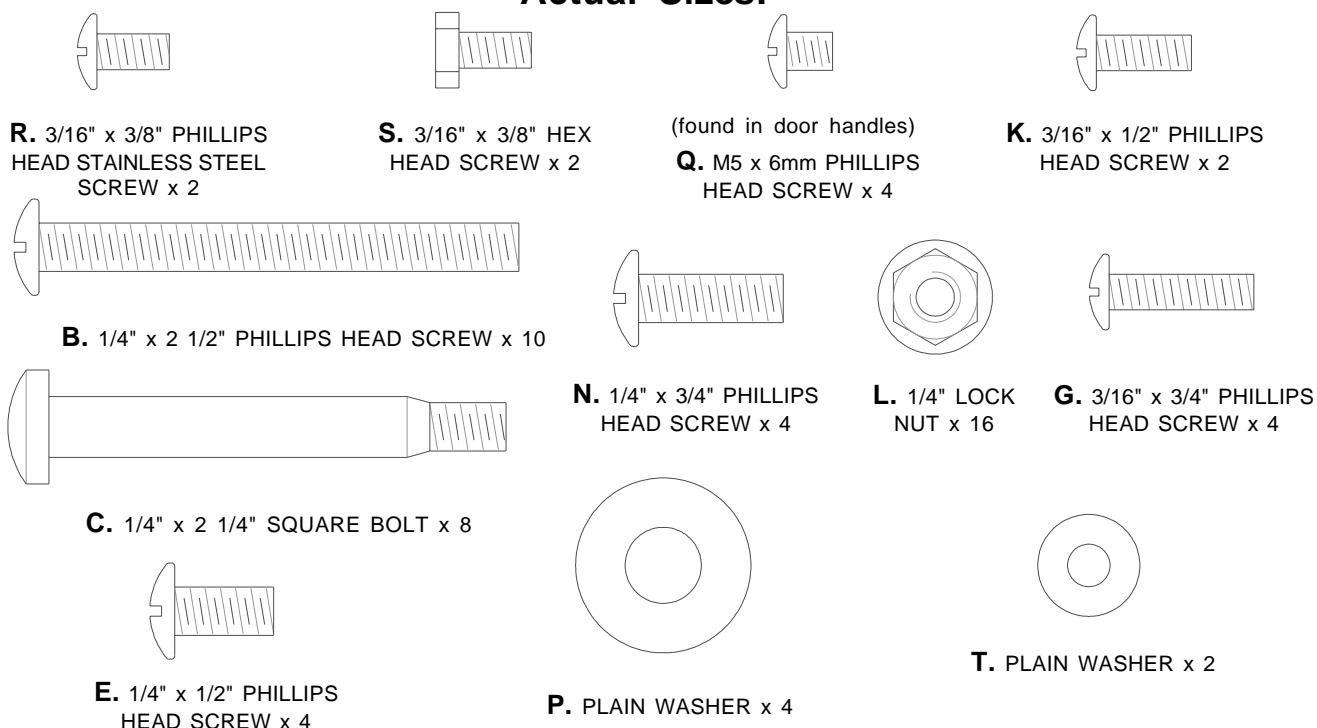

Assembly Instructions

Before attempting to assemble your gas grill, check that all the necessary parts have been included using the parts lists on page 5, 6 and 7. Inspect grill and trolley parts for damage as you proceed. Contact our service center regarding replacement of any damaged parts. Do not assemble or operate a barbecue grill that appears damaged.

While it is possible for an individual to assemble this gas grill, we recommend asking for the assistance of another person when maneuvering some of the larger or heavier pieces. You may need both **Adjustable Wrench** and **Phillips Screw Driver** (not provided) for securing the nuts and screws.

1. Before installing the bottom shelf brackets, make sure: **A)** the ledges of both bottom shelf brackets face each other **B)** the bottom shelf bracket equipped with door stop must be located in the front **C)** the side of Cart Legs having a threaded hole for Door Bracket must face inwards. Refer to ILL. 1.
2. Install the bottom shelf brackets between cart legs. Align the threaded holes on the ends of bottom shelf bracket with the holes on cart legs. Screw loosely using 8 of the "B" 1/4" x 2-1/2" phillips head screws.

HINT: Insert the screw through the Cart Leg, then match the screw end with the threaded hole on the Bottom Shelf Bracket.

3. Attach the Tank Holder to the cross brace between both left-side Cart Legs as shown in ILL. 1. Align the holes on Tank Holder with holes on the cross brace. Fix firmly by using 2 of the "B" 1/4" x 2-1/2" phillips head screws and 2 of the "L" lock nuts.
4. Attach the Tank Hook to the Side Panel as shown in ILL. 1. Align the holes on Tank Hook with holes on the Side Panel. Fix firmly by using 2 of the "E" 1/4" x 1/2" phillips head screws and 2 of the "L" lock nuts.
5. Secure each Caster with 1 of the "P" plain washer to the bottom of the Cart Leg by turning the threaded caster stem clockwise until full stop. Fasten firmly using a wrench. See ILL. 2.
6. Attach the rear panel to the cart legs as shown in ILL. 3. Align the holes on panel with the holes on cart legs. Fix firmly by using 4 of the "G" 3/16" x 3/4" phillips head screws provided. Tighten the loosely attached screws in step 2 for fastening both Cart Legs and Bottom shelf brackets together.
7. Secure the Lighting Stick to the top of the right side panel. The tapping screw is already attached to the lighting stick.
8. Place the 2 bottom shelves over the ledges of both bottom shelf brackets.

ILL. 1

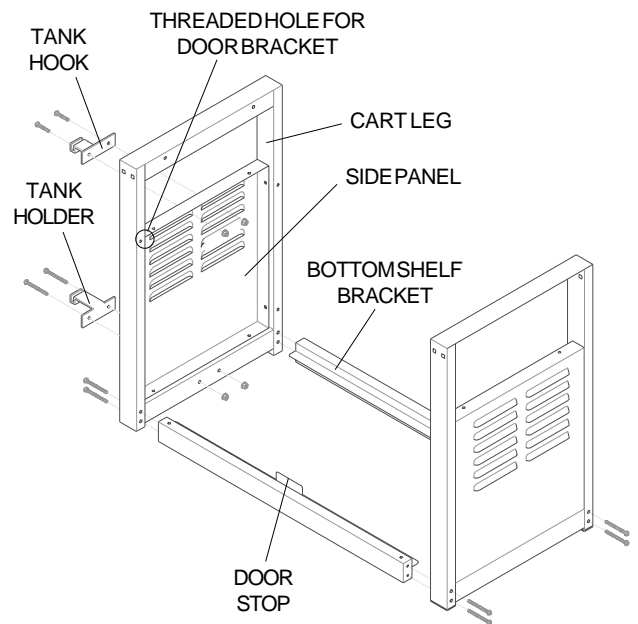

ILL. 2

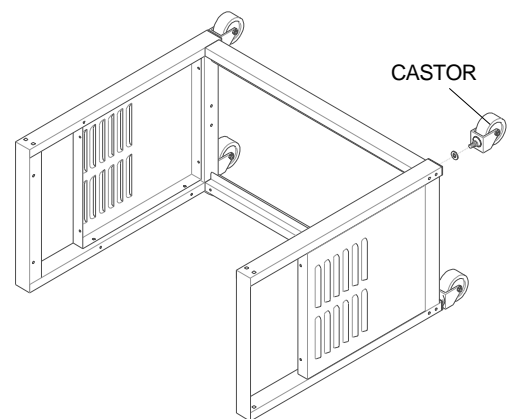

ILL. 3

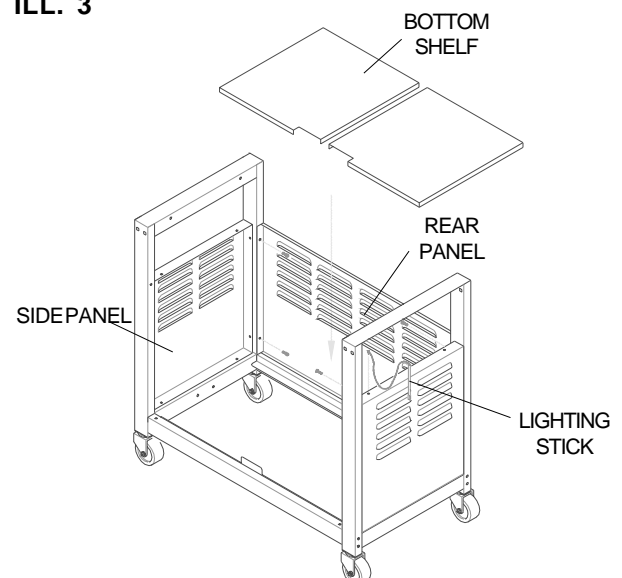

9. Attach (pre-assembled) stainless steel side shelf to the right side of grill as shown in ILL. 4. Align the square holes of the side shelf with holes at upper section of each cart leg. Screw loosely using 4 of the "C" square bolts and 4 of the "L" lock nuts. Slide the U-shape Inserts into each Side Shelf Bracket. The Inserts cover the square bolts inside and add support. Fix firmly by tightening lock nuts.

10. Install the Side Burner to the left side of grill following the same step as Side Shelf.

11. Install Spice Tray to Side Shelf using 2 of the "R" 3/16" x 3/8" phillips head stainless steel screws.

12. Place the Grill Bowl over the cart as shown in ILL. 5. Align the holes on both sides of Grill Bowl with the two (2) holes at the bowl support bracket. Tighten firmly using 4 of "N" 1/4" x 3/4" phillips head screws and 4 of "L" lock nuts. You may have to lift up the Grill Bowl slightly to align the holes properly.

13. Slide the Grease Draining Tray in position over the ledges under Grill Bowl from the rear of Grill. See ILL. 5.

Grease Receptacle should be positioned centrally under Grease Draining Tray.

14. Install the Connection Tube between the outlet of Gas Valve and the inlet of Gas Manifold on the left side of grill bowl. Install the Regulator assembly to the inlet of Gas Valve.

15. Loosely screw 2 of the "S" hex head screws with 2 of the "T" plain washers attached to the Side Burner Bracket. Install the Control Panel by sliding from above. Tighten the loosely attached screws.

16. Install the Control Knob Seat, Spring and then Control Knob onto the Gas Valve Stem. See ILL. 5.

ILL. 4

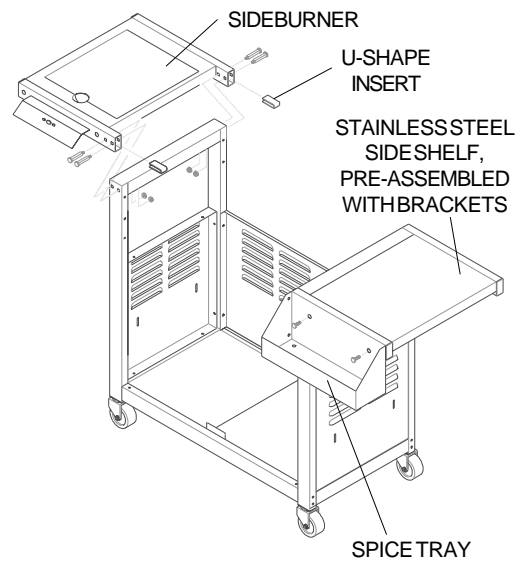

ILL. 5

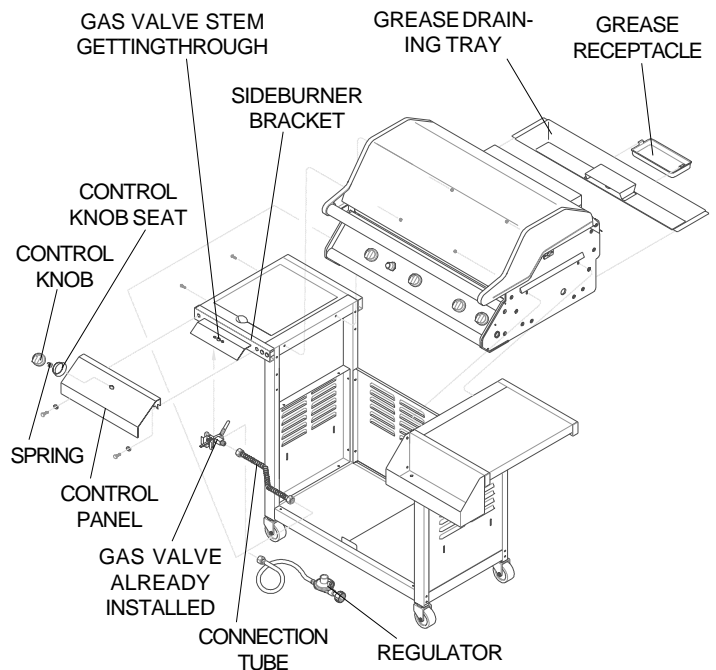

Ignitor Battery Installation - See ILL. 6

- Unscrew the Ignitor Cap located on the grill Control Panel and remove the Contact and Spring from the Ignitor Slot.
- Place the manufacturer supplied AA battery into the Ignitor Slot. Be sure to place the positive pole facing toward you. See ILL. 6.
- Place the Spring over the AA battery, then place the Contact on top of the Spring. Screw the Ignitor Cap back onto the grill Control Panel.

ILL. 6

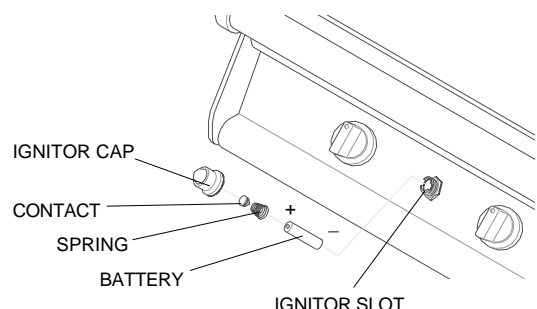

17. Attach the Door Bracket to cart legs (under Control Panel). Be sure the folded strip of the bracket is closest to the cart legs. Then align the holes on both ends of the bracket with the threaded holes on the cart legs. Fix the Door Bracket by screwing 2 of the "E" 1/4" x 1/2" phillips head screws loosely. Refer to ILL. 7.
18. Locate the hinge holes for the door on the Bottom Shelf Bracket. Insert the door hinges into these holes and holes on Door Bracket. Push the Door Bracket down to an even level and then tighten it securely using a screw driver. See ILL. 7.
19. Install the door handles onto the door plates with 4 of the "Q" M5 x 6mm phillips head screws provided.
20. Install the Rear Wind Shield to the back of grill cart. Fix securely using 2 of the "K" 3/16" x 1/2" phillips head screws. See ILL. 8
21. Install the Heat Indicator by inserting it into the hole on upper left side of Grill Lid. Adjust it to level position, then tighten securely using lock washer and wing nut provided in the Heat Indicator box. See ILL. 9.

ELECTRIC IGNITOR / ELECTRODE CHECK

- a. Before placing the flame tamers or cooking grids, ensure that the gap between each spark electrode tip and the collector box is approximately 3/16". Adjust if necessary.
- b. Press the Electric Ignitor button, a blue spark should be produced at the electrode tip. If not, check ignition wire, the terminal of wire to the ceramic electrode could become loose in delivery. Push in the terminal for a tight connection.

Press the Electric Ignitor button for blue spark again.

ILL. 7

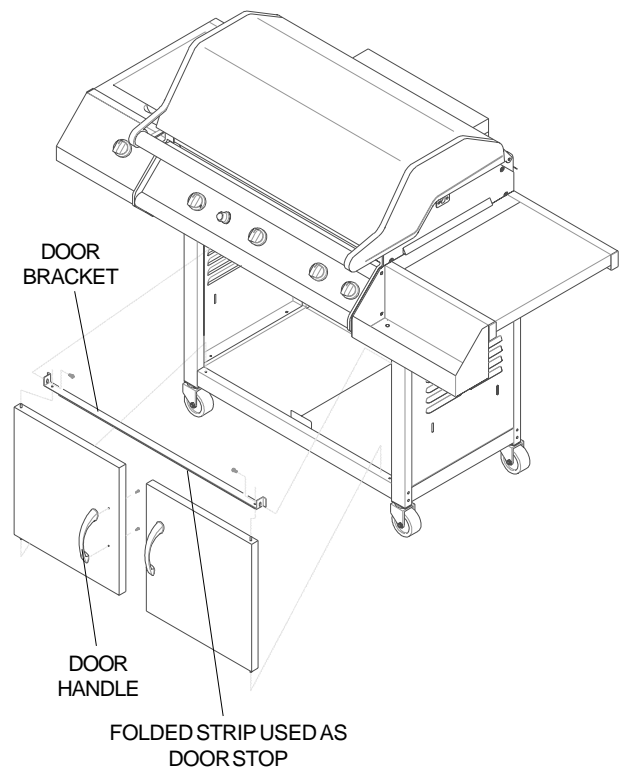

ILL. 8

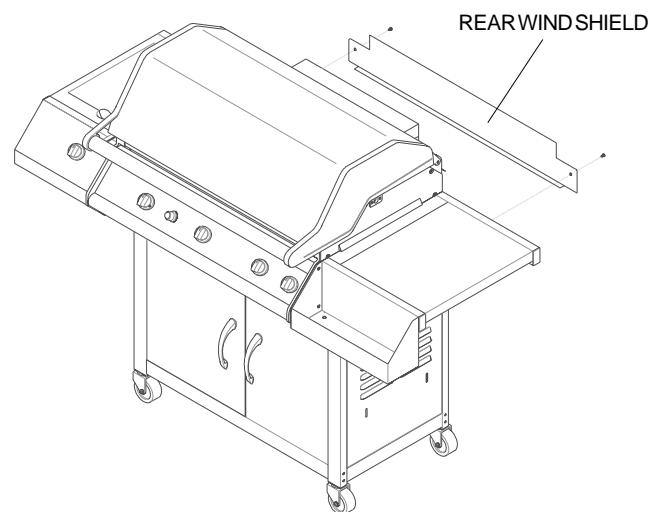

ILL. 9

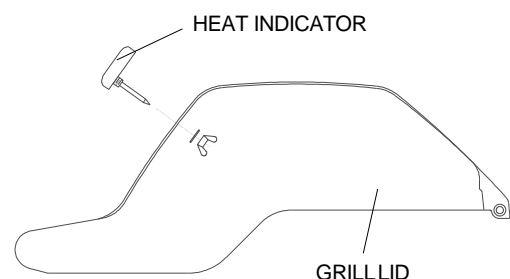

COOKING COMPONENT INSTALLATION

- a. Place the Rack for Ceramic Flame Tamers on the lower ledge above burners. Lay 6 pieces of Ceramic Flame Tamers onto the Rack. See ILL. 10.

NOTE: Make sure the Ceramic Flame Tamers fit into the wire slot properly. If not, reverse the Rack.

- b. Place Cooking Grids on the ledge above Ceramic Flame Tamers.

IMPORTANT: The Grill is not designed for use with lava rock or briquettes and the use of such items will void the warranty.

CONNECTING TO GAS SOURCE

1. Hang filled gas tank on the Tank Hook attached to the Side Panel. See ILL. 11. The ring foot of the gas tank will rest on the Tank Holder. Make sure tank valve is in its full off position (Turn clockwise to stop).
2. Check tank valve features to ensure it has proper external mating threads. (Type 1 connection per 10-94 AGA Requirement)
3. Make sure all burner valves are in their off position.
4. Inspect valve connection ports and regulator assembly. Look for any damage or debris. Remove any debris. Inspect hose for damage. Never attempt to use damaged or plugged equipment. See your local LP gas dealer for repair.
5. When connecting regulator assembly to the tank valve, hand tighten nut clockwise to a positive stop. Do Not use a wrench to tighten. Use of a wrench may damage quick coupling nut and result in a hazardous condition.
6. Open tank valve fully (counter-clockwise). Use a soapy water solution to check all connections for leaks before attempting to light grill. If a leak is found, turn tank valve off and do not use grill until repairs can be made by a local LP gas dealer.

CAUTION: When the appliance is not in use, the gas must be turned off at the supply cylinder.

To disconnect LP gas cylinder:

- a) Turn the burner valve off.
- b) Turn the tank valve off fully. (Turn clockwise to stop.)
- c) Detach the regulator assembly from tank valve by turning the quick coupling nut counter-clockwise.

WARNING :

Now your gas grill is ready to use. Before first use and at the beginning of each barbecue season and whenever LP gas cylinder is changed.

1. Please read safety, lighting and operating instructions carefully.
2. Check gas valve orifices, venturi tubes and burner ports for any obstructions.
3. Perform gas leak check (see page 2).

ILL. 10

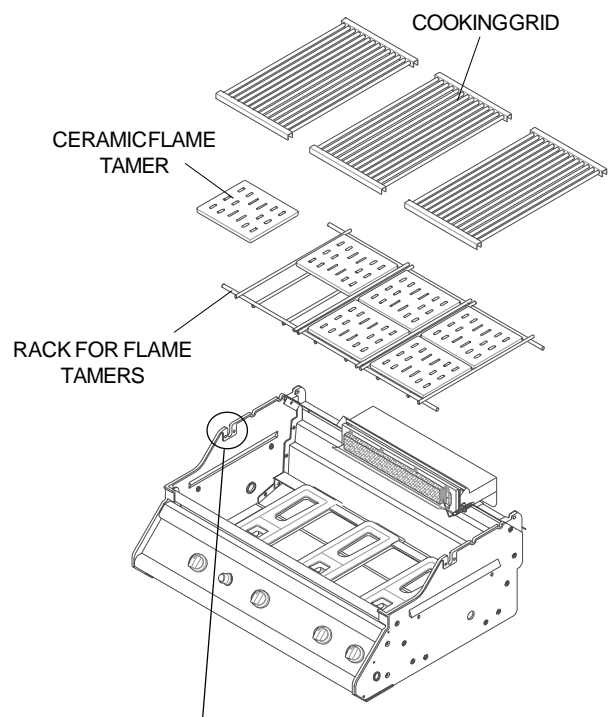

ILL. 11

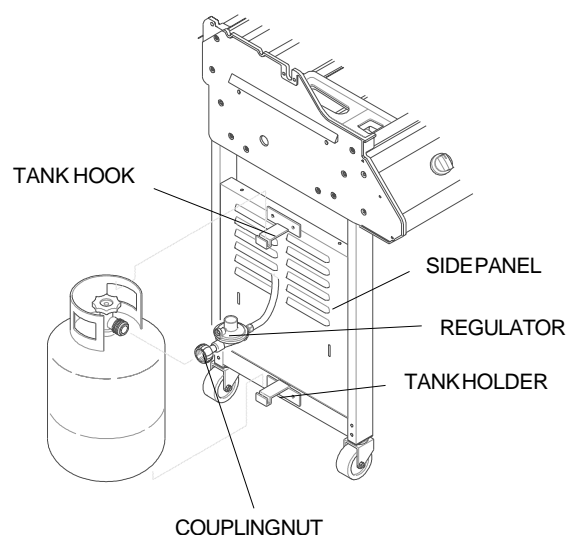

LIGHTING PROCEDURES

1. Become familiar with safety guidelines at front of manual. **DO NOT SMOKE WHILE LIGHTING GRILL OR CHECKING GAS SUPPLY CONNECTIONS!**
 2. Check to see that cylinder is filled.
 3. Check that end of each burner tube is properly located over each valve orifice.
 4. Make sure all gas connections are securely tightened. **TEST FOR LEAKS WITH A SOAP SOLUTION, NEVER WITH A FLAME.** (Gas Leak Check instructions are on page 1).
 5. Always open lid before lighting.
 6. Set control knobs to "OFF" and open the gas supply cylinder valve.
 7. Ignite only the burners you intend to use, using the same method for each:
 - a. Open lid.
 - b. Push Control knob in and HOLD it down while you turn knob left about 1/2". This allows gas to collect.
 - c. After 2 seconds, press the Electric Ignitor button to light.
 - d. If burner does not light, turn gas off and wait 5 minutes before retrial. If unsuccessful after retrial, wait a few minutes and light by match.
 8. Adjust control knob(s) to desired temperature.
- a. Misalignment of burner tube(s) over orifice(s).
CORRECTION: Reposition burner tube to properly seat over orifice.
 - b. Obstruction in gas line
CORRECTION: Remove fuel line from grill. **DO NOT SMOKE!** Open gas supply for one second to blow any obstruction from fuel line. Close off gas supply at source and reconnect fuel line to grill.
 - c. Plugged orifice
CORRECTION: Remove cooking grids and flame tamers. Remove burners from bottom of grill bowl by pulling cotter pin from beneath burner "foot" using a screwdriver or needlenose pliers. Carefully lift each burner up and away from gas valve orifice. Unscrew the orifice from each gas valve and gently clear any obstruction with a fine wire. Re-install each orifice, re-install burners over orifices and seat each burner "foot" into mounting bracket at bottom of grill bowl. Replace cotter pins and cooking components.

If an obstruction is suspected in gas valve(s) or gas valve bracket, please contact your local LP gas service person for assistance.

- d. Misalignment of ignitor on burner
CORRECTION: Check for proper position of electrode tip. The tip of the electrode should be pointing toward the tip of the collector box. The gap between the spark electrode and the tip of the gas collector box should be 3/16". Adjust if necessary. With gas supply closed and all control knobs set to "OFF" check each positive ignitor individually for presence of spark at electrode. In turn, push each control knob in fully and rotate about 1/4 turn to the left (counter-clockwise) until a click is heard; the trigger hitting the strike block should produce a blue spark at the electrode tip. Return control knob to "OFF" before checking next ignitor.

NOTE: As long as one ignitor is in working order, other burners can be ignited from operating burner, in succession. If, for some reason, all ignitors fail to produce a spark at the electrode tip, grill can be lit with a paper book match.

NOTE: To light gas grill with a match, follow steps 1 to 6 above. Then, insert lit paper book match with lighting stick through the lighting hole on right side of grill bowl. Press in right control knob and rotate left to "HI" setting to release gas. Burner should light immediately. If more burners are needed, press in and rotate next control knob to light burners in succession. Turn off burners not needed, and adjust to desired cooking temperature. See Page 14, ILL. 12.

CAUTION: Do not move trolley while grill is in operation.

If the grill fails to operate properly:

1. Turn off gas at source, turn control knob to "OFF", and wait five minutes before trying again.
2. Check gas supply/connections.
3. Repeat lighting procedure and , if grill still fails to operate properly, **TURN "OFF" GAS AT SOURCE, TURN CONTROL KNOBS TO " OFF",** wait for grill to cool and check the following:

If re-ignition is necessary while the gas grill is still hot, you must wait for a minimum of five minutes before commencing to re-ignite (this allows accumulated gas fumes to clear).

If all checks/corrections have been made and gas grill still fails to operate properly, contact the Grand Hall Service Center, or your local LP gas service person.

FLASH BACK:

Should fire occur in and around the burner tubes, immediately turn off gas at its source and turn the control knob(s) to "OFF". Wait until the grill has cooled, then clean the burner tubes and burner ports as described on page 4 of this manual.

OPERATING PROCEDURE

Burn-off: Before cooking on your gas grill for the first time, burn off the grill to rid it of any odors or foreign matter by igniting the burners, closing the lid, and operating at "HI" setting for about five minutes. You may then either set the controls to "OFF" or cook on your grill immediately by turning the control knobs to a lower setting.

CAUTION: Operating grill on "HI" setting for longer than five minutes may damage certain parts of your grill. DO NOT LEAVE GRILL UNATTENDED.

Preheating: The grill lid is to be in a closed position during the preheat time period. It is necessary to preheat the grill for a short time before cooking certain foods, depending on the type of food and the cooking temperature. Foods that require a high cooking temperature need a preheat period of five minutes; foods that require a lower cooking temperature need only a period of two to three minutes. There is no need to pre heat for casseroles, roasts or other foods that require slow cooking.

COOKING TEMPERATURES

HIGH setting - Use this setting only for fast warm-up, for searing steaks and chops, and for burning food residue from the cooking grids after the cookout is over. Rarely, if ever, do you use the HIGH setting for extended cooking.

MEDIUM setting - Use this setting for most grilling, roasting or baking, and for cooking hamburgers and vegetables.

LOW setting - Use this setting for all smoke cooking, rotisserie cooking, and when cooking very lean cuts such as fish.

These temperatures vary with the outside temperature and the amount of wind.

Cooking with Indirect Heat: You can cook poultry and large cuts of meat slowly to perfection on one side of the grill by indirect heat from the next burner. Heat from the lighted burner circulates gently throughout the grill, cooking the meat or poultry without any direct flame touching it. This method greatly reduces flare-ups when cooking extra fatty cuts, because there is no direct flame to ignite the fats and juices that drip down during cooking. Place a drip pan slightly smaller than the cut of meat on the flame tamer surface under the meat being cooked. This will allow you to catch meat juices for making gravy.

Flare-Ups: The fats and juices that drip from the meat cause flare-ups. Since flare-ups impart the distinctive taste and color for food cooked over an open flame, they should be expected and encouraged within reason.

Nevertheless, uncontrolled flaring can result in a ruined meal.

CAUTION: If burners go out during operation, close gas supply at source, and turn all gas valves off. Open lid and wait five minutes before attempting to re-light (this allows accumulated gas fumes to clear).

CAUTION: Should a grease fire occur, close gas supply at source, turn off all burners and leave lid closed until fire is out.

CAUTION: Do not attempt to disconnect any gas fitting while your barbecue is in operation.

As with all appliances, proper care and maintenance will keep them in top operating condition and prolong their life. Your gas grill is no exception. By following these cleaning procedures on a timely basis, your grill will be kept clean and working properly with minimum effort.

CLEANING & MAINTENANCE

CLEANING THE COOKING GRIDS

After cooking, turn control knobs to "OFF" and let grill cool before attempting to clean your cooking grids.

Before first use and periodically it is suggested that you wash the cooking grids in a mild soap and warm water solution. You can use a wash cloth or a vegetable brush to clean your cooking grids if you desire.

CLEANING THE FLAME TAMER

Washing the Flame Tamer after every use is not necessary but periodically it is suggested you wash the Flame Tamer in a soap and warm water solution. Use a wire brush to remove stubborn burnt on cooking residue. Dry the Flame Tamer thoroughly before you reinstall it in the cooking bowl.

CLEANING THE BURNER TUBES AND BURNER PORTS (to prevent FLASH-BACK)

To reduce the chance of FLASH-BACK, the procedure below should be followed at least once a month in late summer or early fall when spiders are most active, or when your grill has not been used for an extended period of time.

1. Turn the burner valve off.
2. Turn gas off at tank. (Turn clockwise to stop.)
3. Detach the regulator assembly from tank valve by turning the quick coupling nut counter-clockwise.
4. Remove cooking grids, flame tamers and grease collectors from grill.
5. Remove burners from bottom of grill bowl by pulling cotter pin from beneath burner "foot" using a screwdriver or needlenose pliers.
6. Carefully lift each burner up and away from gas valve orifice.

We suggest several different ways for cleaning the burner tubes. Use the procedure found on the next page that is most convenient for you:

1. Bend a stiff wire (a lightweight coat hanger works well) into a small hook. Run the hook through each burner tube and into the burner several times.
2. Using a narrow bottle brush with a flexible handle (do not use a brass wire brush), run the brush through each burner tube and into the burner several times.
3. Use an air hose to force air through the burner tube and out through the burner ports. Observe each port and make sure air comes out every hole.

Regardless of which cleaning procedure you use, we suggest you complete the following steps to prolong burner life.

1. Wire brush entire outer surface of burner to remove food residue and dirt.
2. Clean any clogged ports with a stiff wire such as an open paper clip.
3. Inspect the burner for damage (cracks or holes) and if such damage is found, order and install a new burner. After installation, check to insure that gas valve orifices are correctly placed inside ends of burner tubes. Also check position of spark electrode.

CLEANING THE GREASE TRAY

Periodically, the grease tray should be emptied and washed in a mild detergent and warm water solution.

Annual Cleaning of Grill Housing

Burning-off the grill after every cookout will keep it ready for instant use, however, once a year you should give the entire grill a thorough cleaning to keep it in top operating condition.

Interior:

1. Turn the burner valve off.
2. Turn gas off at tank. (Turn clockwise to stop.)
3. Detach the regulator assembly from tank valve by turning the quick coupling nut counter-clockwise.
4. Remove and clean (as explained before) the cooking grids, flame tamers and burners.
5. Cover the gas valve orifices with a piece of aluminum foil.
6. Brush the grill bowl with a stiff wire brush, then wash with mild soap and warm water. Rinse thoroughly and let dry.
7. Remove foil from orifices and check for obstruction.
8. Check for proper position of electrode tip. The tip of the electrode should be pointing toward the tip of the collector box. The gap between the spark electrode and the tip of the gas collector box should be 3/16".
9. Replace burners and adjust spark electrode collector box. Edge of collector box should overlap burner port.

10. Replace flame tamers, cooking grids.
11. Reconnect to gas source and observe burner flame for correct operation.

IMPORTANT: DO NOT line the grill bowl with aluminum foil, sand or any absorbent substance that could prevent drainage to grease collector tray. A grease fire could occur.

Exterior Painted Steel Surfaces:

Much of your grill is made of heavy steel and should provide years of trouble-free service. Should you decide to touch up any scratches in the paint which may occur with use, a touch-up paint designed for use with high temperature is available. Follow these steps for best paint results:

1. Shut off gas supply at source and disconnect fuel line from gas valve manifold. Protect fuel line fitting.
2. Remove loose paint by lightly sanding surface(s) with a medium grit emery cloth or a fine grit sandpaper.
3. Remove any dirt or grease by washing the surface(s) with a mild soap and warm water solution.
4. Rinse with clean water and allow surface to dry thoroughly or wipe the area with vinegar.
5. Apply touch-up paint, following instructions on can.
6. Allow paint to air dry completely, and apply a second coat if necessary. **IMPORTANT:** Let paint dry for 24 hours before using gas grill.

Exterior Stainless Steel Surfaces:

Daily weathering and high heat associated with grill cooking can cause exterior stainless surfaces to "tan". Follow these directions for best results, and **NEVER** clean a hot grill.

1. Shut off gas supply at source and disconnect fuel line from gas valve manifold. Protect fuel line fitting.
2. Remove dirt or grease using a soft cloth, then polish stainless surfaces with a Foam Spray cleaner designed for stainless steel. Never use an abrasive cleaner or scrubber that may scratch your stainless surfaces.
3. Dry with a soft cloth and let air dry before restarting grill.

VISUALLY CHECKING BURNER FLAMES

Occasionally observe burner flame for correct operation. See ILL. 12.

ILL. 12

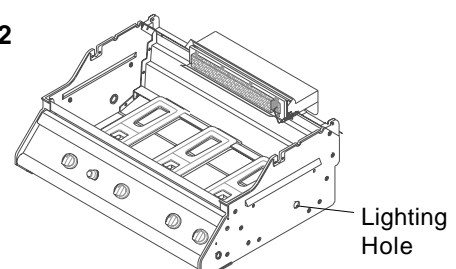

Our Service Center is available during business hours to assist you with your new Bakers & Chefs gas grill. We're here to take your questions, listen to your input, and we're certainly open to new recipe ideas! For your convenience we've listed some of the more commonly asked questions here, but if you have more questions or comments please call us Monday through Friday, 8:00 am to 4:30 pm CST, at 1-800-770-9769.

Q. *I am not familiar with Grand Hall. How long have you been in the gas grill business?*

A. *Grand Hall has been in business for 22 years manufacturing gas regulators, valves, burners, grills and assorted parts and accessories for the grill-related industry. Since 1996 we have been manufacturing the top-of-the-line Bakers & Chefs - a private label grill line commissioned by Sam's Club.*

Q. *I want to convert my Bakers & Chefs LPG (liquid propane gas) grill to natural gas. Is this safe?*

A. *Your Bakers & Chefs gas grill is manufactured to exact specifications and is approved by the American Gas Association (AGA) for use with an LPG cylinder only. We the manufacturer support the U.S. Government in it's efforts to prevent after-market conversions of gas appliances. For your own safety, conversion kits are not available and attempts to convert your grill will void your product warranty.*

Q. *When I mail my Warranty Registration card to the Service Center, will I start getting a lot of junk mail?*

A. *Grand Hall does not sell or offer it's customer list to other companies. You'll notice the card is quick and simple to complete. We only ask for pertinent information that enables us to match your name with the correct model number, date of purchase and serial number - all of which must be on-file if you ever need replacement parts, accessories or want to place a warranty claim. Your information is held private, and will be on-file here at the Service Center. You can mail the card, or fax it directly to (214)-553-0090.*

Q. *My Warranty Registration card asks for the serial number off my grill. Where can I find this information?*

A. *Each Bakers & Chefs gas grill has an individual serial number which may include five numbers and one letter. However, your serial number may be different. You will find this serial number (and the model number) on the silver AGA label, placed on the side of your grill control panel. It is very important to include your serial number on the warranty registration card exactly as it appears on your grill.*

Q. *How long are parts available for my current grill model?*

A. *Grand Hall maintains an ample inventory of parts for current gas grills. In the rare event a grill part has been discontinued or modified, Grand Hall reserves the right to substitute a similar part at our option.*

Q. *The regulator and hose that came with my Bakers & Chefs grill does not fit my older LPG tank. Why?*

A. *The U.S. Government regulates gas appliances and LPG cylinder fittings. Increased regulations have altered the tank fittings over the last few years and they continue to change as the industry develops improved technology. We apologize for any inconvenience, but if your tank does not fit the current regulator it means your tank is outdated and must be replaced.*

Q. *I bought my Bakers & Chefs grill years ago and it looks different from the one I saw in the store recently. What has changed?*

A. *Despite outward appearances, the Bakers & Chefs gas grill remains virtually unchanged. Sam's Club does alter the hood color, cart construction and/or accessory options periodically in order to keep the product line fresh and new. But rest assured, the Bakers & Chefs grill you see today offers the same superior performance, quality and value as all previous models.*

Note: Having your warranty registration card with serial number on file allows our Service Center to match your grill model with the appropriate parts and accessory options.

Q. *I want to take good care of my investment, so what is the best way to clean my Bakers & Chefs?*

A. *As with all appliances, proper care and maintenance will keep them in top operating condition and help prolong their life. Your Bakers & Chefs gas grill is no exception. Follow the "Cleaning & Maintenance" instructions in this instruction manual on a timely basis, and your grill will offer you years of enjoyment.*

Q. *Is it true that stainless steel grill hoods can turn a "wheat" color after use?*

A. *Yes, this is very common with stainless steel hoods because of the intense heat produced from the grill. This coloration does not affect the performance of the grill hood, but you still may want to routinely clean the stainless steel anyway. On a cold grill - with no flame nearby, use paint thinner on a clean cloth and rub onto stainless steel hood. Allow to dry thoroughly before cooking on grill.*

Q. *What can cause grills to rust, and what affect does it have on the materials?*

A. *Rusting is a natural oxidation process and may appear on cast-iron Burners at any time. Because your grill is manufactured with heavy gauge steel, rust will not affect the performance of your grill or affect the taste of your foods. The manufacturer can not warrant against rust unless the components are completely rusted through.*

Q. *How can I remove rust from my grill? Is there a treatment I can use for rust?*

A. *Here is a quick and easy way to remove annoying rust: Brush off rusted surfaces and create a mixture of 1 part vinegar and 1 part water. Spray this solution onto rusted areas to dissolve rust, then scrub with wire brush if necessary.*

Q. *What does treating cast- iron mean, and what is the benefit?*

A. *Treating cast- iron will make foods stick less (which means cooking and clean- up are both easier) and helps prolong the life of cast- iron accessories. It's easy to do, just wipe the cast- iron with vegetable oil, olive oil, canola oil, grease, etc., then heat on high in the grill for a few minutes. After cooking you can wipe a greased cloth along the cast- iron and much of the residue will wipe away so you don't actually have to soak" the accessory. After continued use, the cast- iron will retain flavor and memory of previous recipes, which is what they mean by "seasoned pan." For best results, it is best to treat cast- iron before, and after cooking.*

Congratulations! You are now the owner of the new Bakers & Chefs gas grill, an outdoor kitchen system that is redefining the barbecue. In fact, Bakers & Chefs grill is well on the way to rewriting the art of cooking; making it easier, tastier and more accessible to those who enjoy great food in the great outdoors.

Gone are the days when Dad labored over temperamental charcoal to scorch a steak while Mom raised the temperatures in the kitchen, boiling potatoes and corn. With this revolutionary cooking system, **you're in control**. No more side dishes cooling on the table as they await the underdone meat. And forget about dripping sauces and marinades from the stove to the deck!

Why not stir fry veggies for your vegetarian friends? Or smoke a trout? Perhaps you'll even opt to bake a desert for the sweet tooth in your family.

There's no need for amateur's anxiety. In no time, you'll get a good grip on Bakers & Chefs nearly limitless capabilities. Stir frying. Steaming. Smoking. Stewing. Sauteing. Searing. Deep frying. Roasting. Poaching. Pan frying. Baking. And of course, grilling. Just remember, if you can do it in a kitchen, **you can cook it on your Bakers & Chefs grill**.

Now read over the following cooking methods and recipes. You'll find plenty of delicious, nutritious and do-able recipes that will embellish your table and have guests lining up for more. **Watching the waistline?** Escape the cycle of over-processed convenience foods! What better way to **reduce fat** than by grilling meats or enhancing your diet with more vegetables - prepared to mouth watering perfection?

Whatever your appetite, no matter the recipe, your creativity will soar with this grill that is also an oven, a frying pan, a wok, a smoker and deep fryer. Bakers & Chefs **unique flame control system** ensures perfect results and pleased customers each and every time. So tie on your apron and prepare to rewrite your own culinary history!

BEFORE FIRST USE:

Burn-off: Before cooking on your gas grill for the first time, burn off the grill to get rid of any odors or foreign matter by igniting the burners, closing the lid, and operating at "HI" setting for about five minutes. You may then either set the controls to "OFF" or cook on your grill immediately by turning the control knobs to a lower setting.

CAUTION: Operating grill on "HI" setting for longer than five minutes may damage certain parts of your grill. WHILE COOKING, DO NOT LEAVE YOUR GRILL UNATTENDED.

Outdoor cooking has taken on a new dimension with the introduction of Bakers & Chefs grill. You will quickly come to realize that it is truly a stove on wheels that can do everything from frying, poaching, grilling and smoking to roasting succulent meats.

THE BASICS:

The two methods of cooking referred to frequently throughout this section are **direct** and **indirect cooking**. An explanation of both is necessary before you launch into your first meal. Some recipes will require using both direct and indirect cooking methods.

DIRECT COOKING targets heat (flame) directly under the food. Use this method when grilling and searing meats, poultry or fish. The Bakers & Chefs cooking grids, griddle, cooking pan or wok/saute pan can be used for direct cooking. Side dishes, deep frying and smoking are just a few examples of meals best cooked in this manner. Unless otherwise noted, **direct cooking** requires the **hood to be open**, allowing you to watch as your dinner is prepared.

INDIRECT COOKING is exactly as it sounds. Heat is directed **around the food** from an opposing burner(s) - not the burner directly underneath. Indirect cooking is **always done with the hood down**, creating an atmosphere similar to your kitchen oven. Imagine you want to roast a piece of meat on your Bakers & Chefs grill. You would select the indirect cooking method because it is closest to the way you would roast in your kitchen. First, remove the center cooking grid and insert the cooking pan or griddle, with your meat placed on top. Then, the left and/or right burners are ignited and the hood closed. If you are roasting a large quantity of items that require more space, you may place the items on two cooking grids with the farthest outer burner ignited. Either way, indirect cooking is only effective with the hood down.

PREHEATING YOUR BAKERS & CHEFS GRILL:

The grill lid is to be in a closed position during the preheat time period. It is necessary to preheat the grill for a short time before cooking certain foods, depending on the type of food and the cooking temperature. Foods that require a high cooking temperature need a preheat period of **five minutes**; foods that require a lower cooking temperature need only a period of **two to three minutes**. There is **no need to pre heat** for casseroles, roasts or other foods that require slow cooking.

PREPARATION OF THE COOKING SURFACES:

After preheating your grill, **coat the cooking grids** with cooking oil to prevent food from sticking. When you've finished cooking, leave your grill **running for 5 minutes on high** to burn off food residue. Then brush the cooking surfaces with a fiber or brass wire brush. All cooking surfaces can be further cleaned with hot soapy water. To season your grill, keep cooking surfaces **lightly oiled** at all times. Simply wipe an oiled cloth over the cooking surfaces after each cookout. Vegetable oil is best for this purpose. The seasoning process keeps foods from sticking, and helps prolong the life of your cooking surfaces as well.

Cooking Techniques

Your Bakers & Chefs grill is capable of preparing mouth watering meals using many different cooking techniques. Because every family enjoys different types of cooking, we offer a variety of quality-made cooking accessories that allow you to customize the Bakers & Chef grill to meet your particular needs. The cooking techniques on the following pages incorporate these custom-fit accessories. However, you may use your own cookware to accomplish similar results.

Grill - using the standard Bakers & Chefs stainless steel cooking grids or the optional griddle/hotplate

Rotisserie Cook - using the electric rotisserie

Bake, Roast, Smoke and Deep Fry - using the optional cast-iron cooking pan with lid, and fry basket

Stir Fry - using the optional wok/saute pan

For those watching their calories, grilling is a **low fat** cooking technique that lends itself to a **wide range** of foods. Your Bakers & Chefs grill is a fast heat source that produces the barbecued **appearance and flavor** we all enjoy so much. You can expand dinners for two, to parties for plenty by purchasing larger cuts and quantities of meat which cook beautifully on the grill. This technique doesn't require much experience or skill on your part to produce a superb supper.

It's easy! Prepare to grill by **preheating** for 5 minutes with the burners on high and the hood down. Before placing the food onto the grill, **lightly brush the grill with a little cooking oil**. This step isn't necessary when foods have been marinating in an oil-based marinade.

Your Bakers & Chefs is **now ready to grill**. Remember to keep the **lid open** when cooking directly on the grill. For most foods it's best to **start grilling on high**. Once the food is seared, **reduce the heat to medium**. Foods marinated with ingredients such as honey may burn because of the high sugar content. You should commence their cooking on medium. A favorite on the grill is sausages. Always cook them slowly and if they're particularly fatty, it may be best to partially boil them first.

GRILLING MEAT AND POULTRY

BEEF

Turn burners on high and preheat grill 5 minutes with the hood down. Raise hood and place meat on cooking grid directly above heat source and cook meat on both sides until seared. Then reduce burners to medium and cook until done. Grilling times will vary according to meat thickness, so the following times should be used only as a guide.

CUT OF MEAT

T-bone steak
Sirloin steak
Beef spare ribs
Porter house steak
New York strip steak

APPROX. COOKING TIME

rare: 4-8 minutes
medium: 10-14 minutes
well done: 15-20 minutes

HAMBURGER & SAUSAGES

Follow directions for steak and the times shown to right. For the juiciest burgers and sausages, cook them using the indirect method. Turn burgers with a spatula and use tongs with sausages. Do not puncture meats more than necessary.

Hamburger
Sausages

rare: 4-6 minutes
medium: 8-10 minutes
well done: 10-15 minutes

POULTRY

Turn burners on high and preheat grill 2-3 minutes with the hood down. Raise hood, reduce burners to medium and cook until done. If you prefer to use the indirect method - place poultry in center of grill with left and/or right burners on medium heat and lower hood. Cooking times may vary based on the size of your food. Poultry skin is fatty and may flare-up when cooked directly. So keep an eye on your grill.

Chicken breast
(cook with bone down)
Chicken wings
Drumsticks

Direct method:
approximately 15 minutes

Indirect method:
up to 30 minutes

Whole bird
(cook with breast up)

Indirect method:
approximately 1 hour

PORK

Turn burners on high and preheat grill 5 minutes with the hood down. Raise hood, place pork on cooking grid and cook until seared. Then reduce heat to medium and cook until done. Grilling times will vary according to meat thickness, so the following times should be used only as a guide.

CUT OF MEAT

Pork spare ribs
Chops
Loins
Cutlets

APPROX. COOKING TIME

rare: 4-8 minutes
medium: 10-14 minutes
well done: 15-20 minutes

GRILLING FISH AND SEAFOOD

WHOLE FISH AND WHOLE FILLETS

Grill fish on cooking grid or use the optional griddle (grooved side up). Turn burners on high and preheat grill 2-3 minutes with the hood down. Raise hood, and turn burners to medium heat. Place fish (skin down) on griddle and cook over direct heat until done. Use cooking time as a guide or until fish is opaque but still moist.

Whole fish
Whole fish fillets

approximately 10 - 12 minutes per pound or until fish is opaque

FISH FILLETS AND CUBES

Follow same directions from above, using approximate cooking times shown at right. Because small fish pieces can drop through the grid and into the grill we suggest using the griddle when grilling fish. However, the cooking grid and a small, flat piece of aluminum foil will also work fine.

Fish fillets
Boneless cubes

approximately 4 - 5 minutes each side or until fish is opaque

GRILLING VEGETABLES AND FRUIT

Prepare your fruit or vegetables and brush with butter or basting sauce if desired. To cook **indirectly**, place your food on the center grid with the left and/or right burners lit. Or place your food inside the optional warming rack that hangs inside the grill lid - and light the outer burners. Either way, indirect cooking must be done with the **hood down**.

In some instances, you may want to grill vegetables and fruit **directly** over the heat, using the standard cooking grids or optional griddle. Foods that work best with direct heat are relatively **soft** and require a **short cooking time**, like mushrooms, zucchini, tomatoes and skewered fruit such as apricots, peaches, pineapple, strawberries and kiwis. Remember that the **hood of the Bakers & Chefs should remain up** when cooking directly.

Grilling times using the indirect method with the hood down will be similar to those for your kitchen oven. For very firm vegetables - particularly potatoes and yams - we recommend that you partially boil until almost cooked, before placing them on the grill. Cooking times for foods prepared with the direct method will be much shorter mainly because of the softness of the food. Timing will be comparable to normal pan frying or grilling.

Roasting is effortless on your Bakers & Chefs gas grill. It leaves the chef plenty of time to relax with family and friends and saves hours of cleaning a dirty kitchen oven. Roasting is suitable for prime, tender cuts of meat, poultry and game, many whole fish and some vegetables.

Setting up your Bakers & Chefs grill for roasting is quick and easy. Remember, roasting uses the **indirect cooking** method. Therefore, your food should be placed in the **center of the grill** with the burner lit on the left and/or right side of the grill. Position your meat in a roasting rack (or fry basket - upside down) and then into the cooking pan. Elevating the meat allows you to collect juices in the pan underneath for making gravy. You can also use the standard cooking grid with an aluminum drip pan underneath. Either way, indirect cooking requires **the hood of the Bakers & Chefs grill to be closed.**

Preheating is not required for slow cooking methods such as roasting. However, if you do choose to preheat your grill before roasting - turn burners on high and close hood for approximately 2-3 minutes.

SLOW ROASTING BEEF, LAMB, VEAL OR PORK

TYPE OF FOOD:	HOW COOKED:	APPROX. COOKING TIME
BEEF	rare -	18 minutes per pound
	medium -	23 minutes per pound
	well done -	27 minutes per pound
LAMB	medium -	18 minutes per pound
	well done -	23 minutes per pound
Veal		27 minutes per pound
Pork		30-33 minutes per pound
Chicken		20-25 minutes per pound
Duck		25 minutes per pound
Fish		10 minutes per pound
Turkey - under 16 pounds		20-25 per pound + 30 minutes
- over 16 pounds		18-23 per pound + 15 minutes

Food preparation

Trim meat of excess fat. **Truss** meat and poultry with cooking string to retain shape if desired. **Bacon strips can be used to cover the outside surface of lean meat** and poultry to help **prevent it from drying out.** Another method for keeping food moist during roasting is to put water in the optional cooking pan, and cover the food (and roasting rack) with foil. The foil should be removed for the first or the last part of the cooking time to ensure proper browning.

Tips for roasting

Except when roasting with water in the roasting pan, the **juices that collect in the pan** can be used as the base for a tasty sauce or gravy. Simply place the cooking pan directly over the heat, add extra butter if needed, then add several spoonfuls of flour to thicken sauce. Finally, add sufficient chicken or beef stock to obtain the desired consistency.

Once the meat is cooked, **remove it** from the Bakers & Chefs grill and **cover it** with a piece of foil. Allow it to stand for 10-15 minutes to allow the **juices to settle.** This will make carving easier and ensure a **tender juicy roast.** When **carving, always remember to cut across the grain.**

Smoking gives food a distinctive delicious flavor. The surprisingly speedy and versatile cooking method expands the creative chef's menu with endless new and innovative ways to prepare popular barbecue dishes.

Meat, poultry, game or fish can first be marinated to **enhance the flavor**. You can also rub the food with herbs, spices or flavored oils. An enormous array of foods can be smoked in your Bakers & Chefs grill to produce stunning results with very little effort.

Meal suggestions for smoking:

Tuna steaks: marinated in Asian flavors of sesame oil, soy sauce and sherry

Pork fillets: rubbed with ginger, orange rind and brushed maple syrup

Mussels: brushed with lemon rind and chilli oil

Lamb cutlets: marinated in virgin olive oil, lemon, oregano and black pepper. The same marinade can be used for a whole leg or rack of lamb

Scallops: lightly smoked then served with mango, mixed greens, asparagus, cherry tomatoes and your favorite dressing

All you need for smoking on your Bakers & Chefs is the optional cooking pan and a roasting rack. First, line the inside of the pan with foil. The smoking agent, either pure wood chips or smoking mix, is sprinkled over the foil. Dried herbs and spices may also be added to produce different flavors. **Place the cooking pan directly over the burner**, the heat underneath will eventually produce the smoke to season the food. Elevate your food above the pan using a roasting rack, baking rack or even our optional fry basket will work.

You can **adjust the strength** of the smoke flavor by only smoking for half or three quarters of the cooking time, then roast your food until done. The heat required for smoking is normally **low to medium**.

Foods naturally high in oils lend themselves well to smoking, while drier foods benefit from marinating first. Red meats, poultry, game, fish and seafood can all be smoked easily in your Bakers & Chefs.

Stir-frying Techniques

Now it's time to take a trip to the Orient and try stir-frying. This method of cooking is already popular around the world and can be easily accomplished outdoors on your Bakers & Chefs grill. It's a quick and healthful way of preparing a complete meal of meat, poultry or seafood in infinite combinations with other interesting ingredients like vegetables, rice or noodles.

Meal suggestions for stir-frying:

Chicken: boneless chicken pieces especially sliced breasts

Fish: sliced fillets of firm fish, assorted seafood such as prawns, scallops and calamari

Pork: sliced fillets, diced or minced pork, sliced leg steak, sliced chops

Beef: (sliced) fillet, rib-eye, round, rump, sirloin

Lamb: (sliced) fillet, round, loin

Wok preparation:

Although it is possible to stir fry in other dishes, the wok is your best tool. It's high sides enable the cook to stir food without spilling. It's construction allows you to cook quickly at high temperatures, with instant control of heat which is essential for successful stir frying.

The **wok should be seasoned** to create a smooth nonstick surface. Simply heat the wok directly over a high heat and coat the entire inner wok surface with vegetable oil using a clean paper towel. Repeat the procedure until the paper comes away clean. The **wok is now ready** for action! After cooking, wash the wok in warm, soapy water. Dry, then rub with oil to form a protective film.

Wok cooking method:

Wok cooking is fast. Place your wok/saute pan directly over a high heat on your Bakers & Chefs cooking area. Add only a small amount of food at a time to ensure fast cooking and also to allow the wok to reheat between ingredients.

Food preparation:

Slice meat and poultry across the grain to ensure tenderness

Slice meats and poultry into long thin strips

Cube fish fillets

Remove all fat from meat and poultry

Cut large vegetables into even slices or cubes

Marinate foods for extra flavor and tenderness. Marinating times will vary for red meat, fish and or various cuts. Less tender cuts of meat should be marinated longer. Remember to always chill marinating food in the refrigerator prior to cooking.

Suggested marinating times are:

Meat, poultry and vegetables - up to 24 hours

Fish and seafood - up to 2 hours

Cut like foods - pork and beef for example - into approximately the same size to ensure even cooking. Stir-fry meats, poultry or fish first. Next, add vegetables, "hard" types like carrots first. Then continue with softer vegetables like snowpeas and peppers. To ensure even cooking, continually stir and toss the food in the wok using a wooden spoon or spatula.

Deep-frying Techniques

A **wide variety of foods can be deep-fried on your Bakers & Chefs grill**, from potatoes to seafood and chicken. Deep-frying uses a large portion of oil, preferably saturated. The outdoor location is ideal for deep-frying as smoke and grease and smells reach for the sky - not the inside of your home.

Bakers & Chefs patented gas burner ensures that cooking oil quickly reaches sufficiently high temperatures for deep-frying: it's also designed for easy heat control to prevent burning.

You can deep-fry on your Bakers & Chefs grill using the optional **cooking pan or wok/saute pan**, over direct heat, with the **grill hood raised**.

Fill the cooking pan no more than **half full of vegetable or corn oil**. Start heating, gently at first, then raise the heat. **Check the temperature** of the oil carefully with a frying thermometer or test with a cube of bread. The cube of bread should brown in about 30 seconds for most cooking needs. A temperature between 350 and 400 degrees is optimal for preparing the majority of deep-fried foods. **Add only a small quantity of food to the oil**, allow it to cook, then repeat with another small quantity. This ensures the oil doesn't drop in temperature.

Foods being deep-fried **taste better when coated with either batter or breadcrumbs** to add flavor and prevent moisture from escaping.

Slowly lower foods into the hot oil using the optional wire fry basket. This makes removal of cooked food quicker and easier. Once the food is cooked, **remove it carefully** and **drain onto a paper towel**. Turn the heat off as soon as you have finished deep-frying and **leave the pan to cool**. When the oil is cool, remove all remnants of fried foods by **straining** it through a fine metal sieve. Once the oil is quite cool, store it in a clean bottle for further use.

Rotisserie cooking produces foods that are **moist, flavorful and attractive**, as the turning food self bastes. Although the rotisserie is most commonly used for cooking meat or poultry, nearly anything can be used if prepared properly. The **rotisserie for the Bakers & Chefs grill** includes an extra-long spit and an 8 watt electric motor that is **ideal for preparing small cuts of meat**.

In rotisserie cooking, **balancing the food is of utmost importance**. The rotisserie must turn evenly or the stopping and starting action will cause the food to cook unevenly and possibly burn the heavier side.

The **easiest foods to balance are those of uniform shape and texture**. To test if the food is balanced correctly when secured, place the ends of the rotisserie spit loosely in the palms of your hands. If there is no tendency to roll, give the spit a quarter turn. If it is still stable, give it a final quarter turn. It should rest without turning in each of these positions. It can then be attached to the grill.

When using poultry, truss the birds tightly so that wings and drumsticks are close to the body of the bird. The cavity of the bird may be stuffed prior to this if you wish. Pull the neck skin down and, using a small skewer, fix the back of the bird. Push the rotisserie spit through lengthwise, catching the bird in the fork of the wishbone. Center the bird and tighten with the holding forks. Test the balance as described above.

A rolled piece of meat requires the rotisserie skewer to be inserted through the center of the length of meat, then secured and balanced.

For meats that contain bones, it is best to secure the rotisserie skewer diagonally through the meaty sections. If protruding bones or wings **brown too quickly**, cover with pieces of foil.

Setting up the grill:

Grill Rotisserie System

The grill rotisserie system is designed to cook items from the back burner using infrared heat. The location of the burner allows the placement of a basting pan beneath the food to collect juices and drippings for basting and gravy. To flavor the contents of the basting pan you may add herbs, onions, or other spices of your choice. The rotisserie burner is an infrared type, which provides intense searing radiant heat. This intense heat is magnificent for searing in the natural juices and nutrients found in quality cuts of meat.

Follow the assembly instructions for the deluxe rotisserie system, which are included with grill assembly instructions.

To load the skewer begin with handle in place, and slide one of the meat holders (prongs facing away from the handle) onto the skewer. Push the skewer through the center of the food, and then slide the second meat holder, (prongs toward the food) onto the skewer. It is very important to center and balance the food to be cooked on the skewer then push the meat holders firmly together. Tighten the wing nuts with pliers. It may also be necessary to wrap the food with butcher string (never use plastic or nylon string) to secure any loose portions. Once the food is secure insert the skewer into the motor. If needed, remove the grill cooking grids. Place a basting pan below the food to collect the juices and drippings as the food cooks. It is normal for the skewer to flex when larger cuts of meats are being cooked. It is also not recommended to use the bottom grill burners while the rotisserie burner is in operation. The cooking times on a rotisserie will be approximately the same as for oven cooking.

The rotisserie motor must be electrically grounded in accordance with local codes or, in the absence of local codes, with the National Electric Code, ANSI/NFPA 70-1990. Keep the rotisserie motor electric cord away from the heated surface of the grill. When not in use remove and store the motor in a dry location.

TO LIGHT:

The location of the rotisserie burner makes it more susceptible to strong wind condition than the protected grill burners. For this reason you should avoid operating the rotisserie burner during windy conditions.

- A. Open lid.
- B. Push control knob in and turn very slowly (3 to 4 seconds) to the left about 1/4 turn.
- C. Depress electronic ignition on front of control panel until back burner lights. Then turn control knob to high.
- D. If rotisserie burner does not light, turn gas off and wait 5 minutes before retrial or light by match.
- E. Once lit, the rotisserie burner will reach cooking temperature in about one minute. The orange/red glow will even out in about 5 minutes.
- F. For best results, always use your rotisserie with lid closed and control knob set to high.

Vegetable / Warming Rack

Vegetables are generally easy to cook on the grill. The optional vegetable/warming rack makes it convenient because you can still use the main cooking area while the vegetables are suspended from above!

When cooking vegetables on the warming rack (or grill), you may want to pre-cook long-cooking vegetables by briefly boiling or microwaving them before cooking on the grill.

Wrap vegetables in a double thickness of foil to protect them while cooking. Then, remove the foil if desired, 10-15 minutes before the end of cooking, brush vegetables with butter or oil and finish cooking.

Vegetable kebabs are a good way of cooking an array of small vegetable pieces in the rack. But the warming rack can be used for purposes other than just the obvious. Consider using it for warming French bread, garlic bread, croissants or even bagels.

A small whole fish wrapped in foil also cooks well in the warming rack. Parcels of seafood such as scallops, prawns and sliced fish fillets prepared in a sauce and portioned into small foil wraps cooks well this way too.

Other parts of the Bakers & Chefs grill can still be used for cooking vegetables. Traditionally, roasted vegetables are still best when cooked along side your meats. Grilled tomatoes, eggplant and mushrooms work well directly on the grill.

Certainly not a method of cooking usually associated with the barbecue grill, **baking can be easily done** on your Bakers & Chefs grill. **What a great way to take the heat out of the kitchen!**

There is no limit to the recipes you can bake on the Bakers & Chefs. From casseroles and cornbread to delicious deserts like fondue fruit skewers or crumb cake, **it's as easy as baking in the kitchen.**

Simply **prepare your favorite recipe as usual.** If the recipe requires browning of meat or other food items, use the cooking pan, then add all remaining ingredients as needed. **The cooking pan is your baking dish,** and is placed in the center of the grill - then covered with the lid or aluminum foil. Baking uses the indirect cooking method, with the outer burner(s) on low, for long, slow cooking. You will need to stir the food several times as it bakes, and add additional liquid if required. Watch the temperature, and adjust to cook according to your recipe directions.

OVEN TEMPERATURE:		RECOMMENDED GRILL SETTING:
Slow	300° - 340° F 150° - 170° C	Both outside burners on low
Moderate	355° - 390° F 180° - 200° C	One outside burner on high, and the other outside burner on low
High	410° - 480° F 210° - 250° C	Both outside burners on high

AN IMPORTANT NOTE ABOUT GRILL SETTINGS

The suggested grill settings shown are approximate. There are many factors such as outside temperatures, wind conditions and location of grill (in relationship to the weather) that contribute to your grills temperature and ultimately, the cooking times. An overcooked meal can ruin the fun, so we offer these cooking times as a convenience, but suggest you watch the grill thermometer and adjust the heat accordingly.

ONION BURGERS

A honey and mustard sauce glazes the onion slices as they cook alongside these delicious burgers. For optimal sweetness, select Vidalia or Walla Walla onions. **Makes 4 open face burgers.**

Ingredients:

- 2 large sweet onions, sliced (12 to 16 ounces)
- 2 tablespoons margarine or melted butter
- 2 teaspoons dry mustard
- 2 teaspoons honey
- 1 pound lean ground beef
- 1/4 teaspoon salt
- 1/8 teaspoon pepper
- 4 slices Texas toast
- 4 lettuce leaves
- 4 tomato slices

Preparing onions: Place onions in a cooking pan or on a small piece of aluminum foil. Combine melted margarine, mustard and honey then drizzle over onions. Cover pan with lid - or fold up edges of foil and seal with double fold to completely enclose onions - leaving space for steam to build. Place pan or foil packet on grill - directly over medium heat for 15 minutes with the grill hood up.

Preparing burgers: While onions are cooking, combine ground beef, salt and pepper in a medium bowl and mix well. Shape mixture into four 3/4 inch burger patties and add to grill, directly over heat. Grill burgers along with onions for about 5 minutes then turn burgers. Grill for 8 to 10 minutes more or until no pink remains in meat, and onions are tender. To serve, toast both sides of Texas toast on grill. Then top each slice of Texas toast with lettuce leaf, a burger, tomato slice and one-fourth of the onion. Sprinkle with pepper if desired.

DOUBLE SALSA BURGERS

A fresh tomato salsa flavors the beef mixture for a zesty tasting burger. The salsa also serves as a colorful topping. **Makes 6 burger patties.**

Ingredients:

- 1 large tomato, seeded and finely chopped
- 1/2 cup finely chopped green pepper
- 1/4 cup finely chopped red onion
- 2 finely chopped, seeded jalapeno peppers
- 1 garlic clove, minced
- 1 tablespoon snipped cilantro
- 1/4 teaspoon salt
- 1 1/2 pounds lean ground beef
- 2 cups shredded lettuce
- 1/3 cup finely shredded cheddar cheese
- 1/4 cup dairy sour cream and /or guacamole

Preparing salsa: Combine tomato, green pepper, onion, jalapeno peppers, garlic, cilantro and salt in a bowl. Set aside 2 tablespoons of salsa. Cover and chill remaining salsa until serving time.

Preparing burgers: In another bowl, combine ground beef with 2 tablespoons of reserved salsa, mix well. Shape mixture into six 1/2 inch thick burgers and place on the grill directly over a medium heat with hood up. Grill for 13 to 15 minutes or until no pink remains. Turn burgers once, halfway through grilling time. Arrange the shredded lettuce on individual plates. Top lettuce with a burger, cheddar cheese and salsa. Serve with sour cream and/or guacamole.

CHICAGO STYLE HOT DOGS

Serve these jumbo hot dogs "Chicago-style" with a whole pickled pepper! **Makes 4 servings.**

Ingredients:

- 1/3 cup ketchup
- 1/4 cup chopped pickled peppers
- 2 tablespoons pickle relish
- 2 tablespoons chopped onion
- 1/4 teaspoon poppy seed
- 4 fully cooked 4-ounce jumbo hot dogs
- 4 hot dog buns

Preparation: Combine ketchup, pickled peppers, relish, onion and poppy seed in a small bowl, then set aside.

Place hot dogs on the grill directly over medium heat 5 to 8 minutes - with the hood up. Turn hot dogs and brush with some of the ketchup mixture. Grill hot dogs 6 to 8 minutes more or until thoroughly cooked.

To serve: Toast inner sides of hot dog buns on grill. Serve hot dogs inside buns and top with remaining ketchup mixture.

RIB EYE STEAKS WITH GRILLED GARLIC

As they cook, the garlic cloves mellow in flavor, making a delicious sauce for any grilled meat. And for an appetizer, spread the softened cloves over toasted slices of french bread! **Makes 4 servings.**

Ingredients:

- 1 whole head of garlic
- 2 tablespoons olive oil or cooking oil
- 1 tablespoon snipped fresh basil, or
1/2 teaspoon dried basil, crushed
- 1 tablespoon snipped fresh rosemary or
1/2 teaspoon dried rosemary, crushed
- 2 twelve-ounce boneless rib eye steaks,
cut 1 inch thick

Use a cooking pan, or tear off a 24x18-inch piece of heavy foil and fold long length in half, then trim to make a 12 inch square. Remove the outer layer of garlic head, then cut off and discard the top 1/2 inch of garlic head to expose the garlic cloves. Place garlic head in center of a cooking pan, or in center of foil with all sides of the foil folded up around the garlic to form a cup. Drizzle garlic with oil and sprinkle with basil and rosemary. Cover pan or twist the ends of the foil to completely enclose the garlic.

Place steaks and the garlic pack on grill directly over medium heat and cook about 7 minutes with the hood up. Turn steaks and grill for 5 to 8 minutes more or until cooked to taste. Then remove steaks and place on platter. Remove garlic and drizzle it's juices over your steak. Remove the softened garlic cloves and spread over your steak. Season with salt and pepper as desired and cut into serving-size pieces.

FIVE-SPICE PORK TENDERLOIN

*This delicious tenderloin recipe with teriyake sauce is just one example of the infinite culinary possibilities possible with your new Bakers & Chefs grill. **Makes 6 servings.***

Ingredients:

- 1/4 cup teriyaki sauce
- 1 clove garlic, minced
- 1/2 teaspoon five-spice powder
- 2 twelve-ounce pork tenderloins
- 12 ounces fresh pea pods, strings removed (3 cups)
- 1/2 red pepper, cut to 2-inch strips (1/2 cup)
- 1/2 teaspoon finely shredded orange peel
- 1 tablespoon packed brown sugar

Begin with marinade: combine teriyaki sauce, garlic and five-spice powder. Place whole pork tenderloins in a plastic bag and put into shallow dish. Add marinade and seal bag. Rotate bag to coat meat well, and chill up to 24 hours, turning meat occasionally.

Meanwhile, use a cooking pan - or prepare a 36x18 inch piece of heavy foil, folded in half to make a double thickness piece of foil measuring 18x18 inches. Place pea pods and red peppers in the cooking pot or center of the foil. Sprinkle with orange peel and brown sugar. Cover pan with lid, or fold up all edges of foil and seal to completely enclose this vegetable pack, leave space for steam to build.

To grill: Remove pork tenderloins from bag and reserve the marinade. Put cooking pan in center of grill with a baking rack or fry basket on top - or use the center cooking grid with an aluminum drip pan underneath. Place pork tenderloins on the grill rack. Turn outer burners on low to medium and cook indirectly for 30-35 minutes or until juices run clear. Brush occasionally with marinade up to the last 5 minutes of grilling. Add your vegetable pack the last 15 minutes of grilling, turning once. Remove pork from grill, cover with foil and let stand for 15 minutes before slicing. Serve with vegetables

SWEET AND TANGY BARBECUED COUNTRY-STYLE RIBS

*Serve this tangy bbq classic with corn-on-the-cob, green salad, potato salad or coleslaw! **Makes 4 servings.***

Ingredients:

- 1/2 cup chili sauce
- 2 tablespoons apple jelly
- 1 tablespoon vinegar
- 1 teaspoon prepared mustard
- 1 teaspoon Worcestershire sauce
- 1/4 teaspoon chili powder
- 2 to 2 1/2 pounds country-style pork ribs

In a cooking pan, heat and stir chili sauce and jelly directly over medium heat until jelly melts. Stir in vinegar, mustard, Worcestershire sauce and chili powder, then remove cooking pan from grill, cover and save.

Trim fat , then place ribs in center of grill. Cook with the hood down, using the indirect method and medium heat for 1 to 2 hours - or until ribs are tender and no pink remains. To keep ribs tender and juicy, brush with chili sauce as needed. Once cooked, serve ribs with remaining sauce.

HERB-PEPPER SIRLOIN STEAK

*The hearty beef flavor is complemented with a delicious herb coating! **Makes 6 servings.***

Ingredients:

- 2 tablespoons ketchup
- 1/2 teaspoon coarsely ground pepper
- 1 1/2 teaspoons snipped fresh rosemary or
1/2 teaspoon dried rosemary, crushed
- 1 1/2 teaspoons snipped fresh basil or
1/2 teaspoon dried basil, crushed
- 1/8 teaspoon garlic powder
- 1 1 1/2-pound boneless beef sirloin steak,
cut 1 inch thick

Combine ketchup, pepper, rosemary, basil and garlic powder. Coat both sides of steak with mixture. Grill steak with hood up, directly over medium heat for 6 minutes. Turn steak and grill for 8 to 12 minutes more or until cooked as desired. Cut into serving size pieces.

GRILLED STUFFED MEAT LOAF

*Using the indirect cooking method makes grilling a meat loaf easy work! **Makes 6 servings.***

Ingredients:

- 1 tablespoon margarine or butter
- 2 cups sliced fresh mushroom
- 1 medium onion, thinly sliced
- 2 tablespoons snipped parsley
- 1/2 cup rolled oats
- 1/3 cup milk
- 3/4 teaspoon salt
- 1/4 teaspoon pepper
- 1 beaten egg
- 1 1/2 pounds lean ground beef
- 2 tablespoons ketchup
- 1 teaspoon mustard

Place a cooking pan directly over low heat and heat margarine or butter until melted. Adjust heat to medium, add mushrooms and onion and cook for 5 minutes or until vegetables are tender. Stir in parsley and turn off burner allowing this mushroom and onion mixture to cool.

Next, stir together rolled oats, milk, salt, pepper and egg then add ground beef and mix well. Flatten mixture to a 12x8-inch rectangle on waxed paper. Spoon mushroom and onion mixture evenly onto meat then roll up, starting with 8-inch end. Pinch all edges of loaf together to seal. In a small bowl, stir together ketchup and mustard.

Place cooking pan with fry basket or baking rack into center of grill with outer burners on medium to low heat. Cook meat loaf on top of rack with hood down for up to 1 hour or until no pink remains (you may place a small piece of foil under the loaf while cooking). Brush loaf with ketchup mixture the last 5 minutes of cooking. After cooking, remove loaf from grill and cover with foil. Let stand 15 minutes then serve.

MARINATED TUNA STEAK

*Experiment with unique dishes, like this tuna steak recipe with a delicious wine marinade! **Makes 4 servings.***

Ingredients:

- 4 6-ounce fresh or frozen tuna steaks cut 1 inch thick. Thaw fish if frozen
- 1/3 cup dry white wine
- 1 tablespoon lemon juice
- 1 tablespoon olive oil or cooking oil
- 1 clove garlic, minced
- 2 teaspoons snipped fresh rosemary, crushed, or 1/2 teaspoon dried rosemary, crushed
- 1 teaspoon snipped fresh oregano, crushed, or 1/4 teaspoon dried oregano, crushed
- 1/4 teaspoon salt

Prepare marinade: combine wine, oil, garlic, rosemary, oregano and salt. Place tuna steak in plastic bag and into shallow dish, add marinade then seal bag. Rotate bag to coat fish well then chill for up to 2 hours, turning fish once.

Remove fish from bag and discard marinade.

Place a cooking pan with fry basket or baking rack into center of grill with outer burners on medium heat. Cook tuna steak on top of rack with hood down for 8 to 12 minutes or until fish begins to flake easily. Turn fish once during cooking. When cooked, remove fish from grill and serve.

MUSTARD-GLAZED HALIBUT STEAKS

*A simple sauce of melted margarine, lemon juice, Dijon-style mustard and basil adds a scintillating note to these sizzling fish steaks! **Makes 4 servings.***

Ingredients:

- 4 6-ounce fresh or frozen halibut steaks, cut 1 inch thick
- 2 tablespoons margarine or butter
- 2 tablespoons lemon juice
- 1 tablespoon Dijon-style mustard
- 2 teaspoons snipped fresh basil or 1/2 teaspoons dried basil, crushed

Place a cooking pan - or aluminum foil rectangle, directly over low flame and combine thawed fish, margarine or butter, lemon juice, mustard and basil. Heat mixture until melted. Brush mixture over both sides of halibut fish steaks. Pour balance of mixture into small bowl.

Place clean cooking pan or foil on center of grill with both outer burners on medium. Place fish on grill and close hood. Cook indirectly for 8 to 12 minutes or just until fish begins to flake easily, turning once and brushing as needed with reserved mixture.

SOUTHWEST CHICKEN BREASTS

*This popular recipe can easily be a grilled chicken salad! Slice chicken into small strips and place them on top of shredded lettuce with avocado mixture as dressing and topped with cheese! **Makes 6 servings.***

Ingredients:

- 1/4 cup dry white wine
- 2 tablespoons olive oil or cooking oil
- 2 teaspoons snipped fresh tarragon or
1/4 teaspoon dried tarragon, crushed
- 1/4 teaspoon salt
- 6 skinless, boneless chicken breast halves
- 2 avocados, pitted, peeled and chopped
- 1 tomato, chopped
- 1 clove garlic, minced
- 2 tablespoons finely chopped seeded
green chili peppers of your choice
- 2 green onions, finely chopped
- 1 tablespoon snipped fresh cilantro
- 1 tablespoon honey
- 1 tablespoon lemon juice

For marinade: combine wine, oil, tarragon and salt. Rinse chicken and dry with paper towels. Place chicken in plastic bag and into shallow dish then add marinade and seal bag. Rotate chicken to coat well and chill up to 24 hours, turning bag occasionally.

Combine avocados, tomato, garlic, chili peppers, onions, cilantro, honey and lemon juice. Toss well then cover and chill up to 2 hours.

Remove chicken from plastic bag and re-serve the marinade. Grill chicken directly over medium heat with hood up for 5 minutes. Turn chicken and brush with marinade, then grill for 5-10 minutes more or until chicken is no longer pink. Serve with side of avocado mixture.

BARBECUED CHICKEN

*Another backyard favorite, this recipe includes an easy to make - sweet and spicy sauce. **Makes 4 servings.***

Ingredients:

- 1/2 cup ketchup
- 1/4 cup orange marmalade
- 1 tablespoon vinegar
- 1/2 teaspoon celery seed
- 1/2 teaspoon chili powder
- 1/4 to 1/2 teaspoon bottled hot pepper sauce
- 1 2 1/2 to 3 pound broiler-fryer chicken, cut up

Prepare sauce in a cooking pan on grill directly over a low to medium heat. Combine ketchup, marmalade, vinegar, celery seed, chili powder and hot pepper sauce. Leave the cooked sauce in the pan - and remove from heat until chicken is prepared.

Wash chicken and dry with paper towels. Turn outside burners on medium and place chicken pieces (bone side down) on center cooking grid. Close hood and cook indirectly for 1 hour or until chicken is no longer pink. Brush occasionally with sauce. Remove chicken from grill once cooked, then place cooking pan with sauce into center of grill and reheat. Pour warmed sauce over chicken and serve.

SOUTHERN FRIED CHICKEN WITH TOMATO AIOLI

*There's no need to fill the house with the fumes from fried chicken. Our Bakers & Chef cooking pan and fry-basket make preparing this classic southern recipe easier than ever! **Makes 4 servings.***

Fried Chicken Ingredients:

- 4 chicken breasts
- 1 egg, lightly beaten
- 1/2 cup milk
- 1 cup all purpose flour
- 2 tablespoons dried thyme
- 1 tablespoon dried rosemary
- 1 1/2 teaspoon salt
- 1/2 teaspoon onion powder
- 1 teaspoon sugar
- 2 or 3 teaspoons paprika
- 1 teaspoon chilli powder
- oil for frying

Tomato Aioli Ingredients:

- 1 clove garlic, crushed
- juice of 1 lemon
- 3 egg yolks
- salt to taste
- 3/4 cups oil
- 2 tomatoes, finely diced
- 1/4 cup chopped chives

Cut chicken into bite-sized portions. Combine eggs and milk together. Sift remaining dry ingredients together. Dip chicken into milk mixture then coat in flour. Repeat process a second time if desired. Half fill cooking pan with oil and heat over a high flame. Place chicken into a frying basket and lower into the hot oil. Cook until golden brown, approximately 2 minutes. Drain and serve with tomato aioli.

Place garlic, lemon juice, egg yolk and salt into a blender, and blend until smooth. Add oil in a slow, steady stream with blender operating. Sauce will become thick as you add oil. Fold in tomatoes and chives.

CHICKEN BURRITOS

*Another easy-to-prepare recipe for your Bakers & Chefs grill that makes dining and entertaining at home more fun than eating out. **Makes 4 servings.***

Ingredients:

- 2 tablespoons olive oil
- 1/4 cup lemon juice
- 1 garlic clove, crushed
- 1/2 teaspoon black pepper
- 1/4 teaspoon cayenne pepper
- 1/4 teaspoon chilli powder
- salt to taste
- 4 boned chicken thighs cut into thirds, lengthwise
- 2 cups commercial tomato salsa
- 1/4 cup yogurt or sour cream

Combine the first seven ingredients into a glass or ceramic dish. Add chicken to the marinade and refrigerate for several hours. Cook chicken on pre-heated Bakers & Chefs grill directly over a high heat until done. Warm tortillas on the grill as the chicken is being prepared. Top tortillas with sliced chicken, tomato salsa, yogurt or sour cream and serve.

SESAME BEEF ROAST

A delicious way to spice up weeknight dinners! They'll ask for repeats of this roast dinner. Makes 6 - 8 servings.

Ingredients:

- 1/3 cup sesame seeds
- 1/2 cup salad oil
- 1/2 cup soy sauce
- 1/3 cup lemon juice
- 2 tablespoons white wine vinegar
- 1 tablespoon sugar
- 2 cloves garlic, minced or pressed
- 1 medium size onion, sliced
- 4 pounds crossrib or sirloin tip roast

Place a cooking pan in grill over medium heat and toast sesame seeds for 3 minutes or until golden brown, stirring frequently. Remove from heat and add oil, soy sauce, lemon juice, vinegar, sugar, garlic and onion.

Place meat in large plastic bag and into shallow dish. Pour marinade into bag over meat and chill for 8 to 24 hours, rotating bag occasionally to coat meat. After marinating, remove meat from bag and drain slightly, reserving the marinade.

Place meat on a baking pan or roasting rack above the cooking pan in the center of your grill. Cook indirectly with outer burners on medium heat and hood down -for 1 1/2 to 2 hours or until no pink remains. Brush meat with marinade occasionally. Let stand for 10 minutes before serving and cut across the grain into thin slices.

TRADITIONAL HOLIDAY TURKEY

Imagine their surprise when you entertain your next holiday gathering with a traditional turkey - complete with dressing - delicious and tender straight from the grill! Serves 8 - 10

Breadcrumb dressing ingredients:

- 2 ounces butter
- 2 onions, finely chopped
- 8 ounces bacon, chopped
- 2 tablespoons port wine
- 1/4 cup red wine
- 2 chicken stock cubes
- 4 ounces chopped cashews, hazelnuts or pecans
- 1/2 cup chopped celery
- 1/2 cup chopped carrot
- 1 - 1 1/2 cups fresh white breadcrumbs
- 1 egg, lightly beaten
- salt and pepper to taste

Prepare dressing in a cooking pan directly over medium heat. Melt butter, add onions and bacon then saute 3 minutes. Add port, red wine and stock cubes and bring to a boil. Cook 2 minutes. Remove pan to allow ingredients to cool. Add remaining ingredients and mix.

Turkey ingredients:

- 8 - 10 pound whole turkey
- 4 ounces butter, softened
- 2 tablespoons chopped thyme
- 2 tablespoons lemon juice
- 2 teaspoons grated lemon rind

Wash inside of turkey and dry with paper towels. Pack breadcrumb seasoning into the turkey cavity. Combine the butter, thyme, lemon juice and rind together in bowl. Using turkey baster, insert butter mixture under skin covering the turkey breast.

Truss turkey with string and place on a baking pan or roasting rack, above a cooking pan in the center of your grill. Turn one outside burner to low, the other to medium, and close hood. Cook indirectly for 3 1/2 to 4 hours or until cooked. Halfway through cooking time you may alternate burner temperatures so that the turkey browns evenly. Once cooked, remove dressing from cooked turkey, slice and serve.

PIZZA ON THE GRILL

You may never want to call out for pizza again! Follow this recipe and make your pizza dough from scratch, or purchase ready-made pizza dough (found in your grocers refrigerated section - next to the biscuits) which fits our optional cooking pan perfectly! Slice and serve directly from the grill! Serves 6 - 8

Ingredients:

- 1 1/2 teaspoons dried yeast
- 1 cup lukewarm water
- 1/2 teaspoon sugar
- 3 tablespoons olive oil
- 3 cups all purpose flour
- 1/4 cup tomato paste or Italian tomato sauce
- 6 ounces sliced pepperoni
- 1 red pepper, roasted and sliced
- 3/4 cup pitted black olives
- 8 ounces grated mozzarella cheese

It's easy to customize this recipe with toppings to suit your family's taste. **For spicier crust**, lightly rub the dough with olive oil then spice with pepper and garlic salt before spreading your tomato sauce.

Combine yeast, water and sugar together and let stand in a warm place until mixture starts to foam. Add this yeast mixture to flour and oil and combine to form your pizza dough. Knead on a lightly floured surface until smooth and elastic. Cover and stand in a warm place until doubled in size. Knock back dough and roll out to a rectangle the size of your cooking pan - or baking dish. Place dough into lightly oiled pan.

Spread dough with tomato paste or Italian tomato sauce. Top with pepperoni, red peppers, olives, and lastly - mozzarella cheese. Or if you prefer, you may place cheese first with toppings on last.

Place cooking pan in center of grill and cook indirectly - with one outside burner on high and the other on low, for approximately 20 minutes or until bottom of crust is light brown. Lastly, raise the hood and finish cooking pizza by turning burner under the cooking pan on high for about 2 minutes. This will insure the center of pizza gets brown. Then turn off heat, slice and serve directly from pan.

FRESH VEGETABLE STIR-FRY

Take a trip to the Orient with this easy, and healthy vegetable recipe. Makes 4 - 6 servings.

Ingredients:

- 2 tablespoons oil
- 1 onion, cut into wedges
- 1 carrot, thinly sliced
- 2 cups broccoli, cut into small flowerets
- 1 red pepper, sliced
- 2 sticks celery, thinly sliced
- 1 cup snow peas
- 1/2 cup chicken

Heat oil in a wok or saute pan, directly over a high heat. Add onion and cook 1 minute. Add carrot and broccoli and stir-fry 2 minutes, then add red pepper, celery and snow peas and continue cooking 1 minute more. Add stock and toss vegetables until cooked to desired degree

GRILLED POTATO SKINS

Serve these crispy potatoes as a snack or side dish. We've included microwave instructions for a timesaving short cut. **Makes 12 servings.**

Ingredients:

- 6 baking potatoes (about 8 ounces each)
- 3 tablespoons margarine or butter, melted
- 1/2 cup picante sauce
- 1 cup shredded cheddar cheese (4 ounces)
- 3 slices bacon, crisp-cooked and crumbled
or - use prepackaged bacon bits
- chopped tomato (optional)
- diced green onion (optional)
- 1/2 cup sour cream (optional)

Prick clean potatoes with a fork, wrap in heavy foil and place them directly over low to medium heat. Close hood and cook directly for 1 hour or until center is tender. **OR - Microwave** clean, pricked potatoes on high for 15 to 20 minutes, or until center tender.

Allow cooked potatoes to cool then unwrap and discard foil.

Cut potatoes in half - lengthwise. Scoop out potato pulp (serve separately or discard.) Be sure to leave 1/4 inch thick potato shell remaining. Then, brush the inside of each potato shell with melted margarine. Spoon 2 teaspoons picante sauce into each potato shell and sprinkle with cheese and top with bacon.

Place prepared potato skins on grill, directly over medium heat. Close hood and cook for 8 to 10 minutes or until potato skins are crisp. Sprinkle each potato skin with tomato and green onion and then top with sour cream, if desired.

ONION BLOSSOMS

Great served as a snack, or to dress up barbecued meats, poultry or fish. **Makes 4 servings.**

Ingredients:

- 4 medium sweet onions (4-5 ounces each)
- 1 tablespoons margarine or butter, melted
- 1 teaspoon Dijon-style mustard
- 1/8 teaspoon hot pepper sauce
- 1 tablespoon brown sugar

pepper (optional)

Peel onions, then cut almost completely through each onion, forming 8 wedges. Onion will be loose, but should still be intact. Prepare four 12-inch squares of heavy foil. Place one onion in the center of each foil square.

Stir margarine (or butter) with hot pepper sauce and drizzle over onions. Sprinkle with brown sugar. Then bring up two sides of foil square and double fold. Bring remaining two corners up and completely enclose - leaving enough space for steam to build.

Place wrapped onion blossoms on grill, directly over medium heat. Close hood and cook 15 to 25 minutes or until onions are nearly tender. Make a 2-inch opening at the top of each onion wrapping, then close hood and cook 5 to 10 minutes more, or until onions are lightly browned. Sprinkle with pepper if desired and serve warm.

BAKERS & CHEFS LIMITED WARRANTY

GHUSA warrants to the original owner of each Bakers & Chefs Gas Grill that it is free from defects in workmanship and materials under conditions of normal residential use. GHUSA will repair or replace warranty parts according to the list below. There will be a charge for shipping and handling.

2 YEAR WARRANTY	1 YEAR WARRANTY
Cast Iron Burner (2 year no rust through) Grill Bowl (2 year no rust through) Stainless Steel Cooking Grids Stainless Steel Grill Lid Steel Cart	Ceramic Flame Tamer Hose & regulator Caster & Caster Seat Thermoplastic Control Knob (excludes paint fading) Cast Aluminum Parts (1 year paint fading) Grease Receptacle (1 year no rust through) Grease Draining Tray (1 year no rust through) Electronic Ignition (excluding battery)

The extent of any liability of GHUSA under warranty is limited to repair or replacement. The warranty period is not extended by such repair or replacement.

This warranty does not apply to any damage due to transportation, installation, purchaser servicing, accident, abuse, fire, alteration of the product in any way, act of God, or failure to read and/or abide any product warnings, or any parts or labor used to replace any part or parts covered under this warranty.

THIS WARRANTY IS IN LIEU OF ANY OTHER EXPRESS OR IMPLIED WARRANTY THAT MAY APPLY TO THIS PRODUCT. THIS DISCLAIMER OF IMPLIED WARRANTY MAY NOT APPLY TO YOU BECAUSE SOME STATES DO NOT ALLOW DISCLAIMER OR IMPLIED WARRANTIES.

A PARTIAL LIMITATION ON IMPLIED WARRANTIES TO LIMIT THE DURATION OF SUCH WARRANTIES TO THE DURATION OF AN EXPRESS WARRANTY IS ALLOWED IN SOME STATES, IN SUCH STATES, THEREFORE, THE DURATION OF THE IMPLIED WARRANTIES IS HEREBY EXPRESSLY LIMITED TO THE DURATION OF THIS LIMITED WARRANTY.

IN NO EVENT, WHETHER AS A RESULT OF BREACH OF WARRANTY OR CONTRACT, NEGLIGENCE, STRICT LIABILITY, OR MISREPRESENTATION, WILL GHUSA BE LIABLE FOR ANY SPECIFIC, INCIDENTAL, OR CONSEQUENTIAL DAMAGES. THIS EXCLUSION OF LIABILITY IS NOT ALLOWED IN SOME STATES, THEREFORE, THIS EXCLUSION MAY NOT APPLY TO YOU.

GHUSA DOES NOT ASSUME, OR AUTHORIZE ANY OTHER PERSON TO ASSUME FOR GHUSA, ANY LIABILITY FROM THE SALE OF THIS PRODUCT BEYOND THAT EXPRESSLY SET FORTH IN THIS LIMITED WARRANTY.

THIS WARRANTY GIVES YOU SPECIFIC RIGHTS. THE LAWS OF YOUR STATE MAY GIVE YOU ADDITIONAL RIGHTS.

FOR WARRANTY SERVICE, PLEASE CALL OUR SERVICE CENTER AT 1-800-770-9769, MONDAY THROUGH FRIDAY, 8:00 AM TO 4:30 PM CST.

AGA label located here

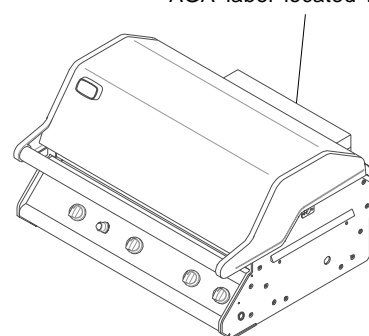

IMPORTANT

In order to keep you informed about Bakers & Chefs Grill updates, accessories and new recipe ideas, we must have your Warranty Registration Card with your model number and serial number on file. (See silver AGA label for these numbers)