

This Owner's Manual is provided and hosted by [Appliance Factory Parts](#).



AMANA AM33 (2007) Owner's Manual

[Shop genuine replacement parts for AMANA AM33
\(2007\)](#)



[Find Your AMANA Grill Parts - Select From 25 Models](#)

----- Manual continues below -----



Amana™ SS 5 Burner Grill w/ Rear Burner



USE AND CARE MANUAL FOR OUTDOOR USE ONLY

ALWAYS KEEP YOUR GRILL COVERED WHEN NOT IN USE

BEFORE YOU BEGIN – We' ve included easy-to-follow, step-by-step instructions which have been carefully written to ensure quick assembly of your grill. Reading the instructions will be a time saver in the end.

TOOLS YOU WILL NEED – A Phillips screwdriver, adjustable wrench, 1/2" wrench or socket and a 1/4" nut driver or socket will be needed to assemble this grill. All other necessary hardware has been included.

Questions, Missing or Damaged part? DO NOT RETURN PRODUCT TO STORE

We're here to help. Just call 1-800-229-5647. For faster service, have model number and serial number on hand when calling.

IMPORTANT SAFETY INFORMATION



- Read this manual carefully before using your grill to reduce the risk of fire, burn hazard or other injury.
- Extreme care should be used because of the high temperatures produced by this appliance. **CHILDREN SHOULD NOT BE LEFT UNATTENDED IN AN AREA WHERE THE GRILL IS BEING OPERATED.**
- This appliance must be kept clear from combustible materials, gasoline or other flammable vapors and liquids. Do not allow flammable materials to come in contact with grate, burner or hot surfaces.
- Use only outdoors and provide good ventilation to avoid carbon monoxide build-up which could result in injury or death.
- Do not repair or replace any part of this appliance unless it is specifically recommended in this manual. A qualified service technician should conduct all other service.
- Follow the installation and servicing instructions provided with this product. Have your grill installed by a qualified service technician.
- Locate the main gas supply valve so that you know how to shut the gas off to your grill.
- If you smell gas, make sure all gas connections are tight before operation. If you continue to smell gas call a qualified technician.
- When lighting a burner, always pay close attention to what you are doing and be certain you are pushing the igniter that lights the burner you intend on using.
- Always keep your face and body as far away as from the grill as possible when lighting to reduce the risk of burn.
- Extinguish all flames and do not smoke while engaging gas and igniting the grill.
- A minimum distance of at least 12" must be maintained from any combustible material on both sides and the back of the grill. Do not place the grill under any overhead unprotected combustible construction.

RECOGNIZE SAFETY SYMBOLS, WORDS AND LABELS



WARNING indicates a potentially hazardous situation which, if not avoided, could result in death or serious injury.



NOTE indicates an important piece of information that needs to be observed to ensure the proper operation of your grill.

DANGER

If you smell gas:

1. Shut off gas to the appliance.
2. Extinguish any open flame.
3. Open lid.
4. If odor continues, keep away from the appliance and immediately call your gas supplier or your fire department.

WARNING

1. Do not store or use gasoline or other flammable liquids or vapors in the vicinity of this or any other appliance.
2. An LP cylinder not connected for use shall not be stored in the vicinity of this or any other appliance.

INSTALLER: Please retain these instructions with the owner so that they may maintain them for future reference.

Welcome & Congratulations

Congratulations on your purchase of a new grill! We are very proud of our product and we are completely committed to providing you with the best service possible. Your satisfaction is our #1 priority.

Please read this Use & Care Manual very carefully. It contains valuable information on how to properly maintain your new grill.

We know you'll enjoy your new grill and thank you for choosing our product. We hope you consider us for future purchases.

PLEASE READ AND SAVE THESE INSTRUCTIONS

This Use & Care Manual provides specific operating instructions for your model. Use your grill only as instructed in this manual. These instructions are not meant to cover every possible condition and situation that may occur. Common sense and caution must be practiced when installing, operating and maintaining any appliance.

Please record your model and serial numbers below for future reference. This information is found on the serial plate located on the inside of the grill door.

NOTE: Use only soap and water to clean serial plate.

Model Number: _____

Serial Number: _____

Purchase Date: _____

Gas Type: _____

Please complete and mail in the **Product Registration Card** included with your grill.

Questions?

1-800-229-5647

for written inquiries:

**Sure Heat Manufacturing
3130 Moon Station Rd
Kennesaw, GA 30144**

Register Your Product

The PRODUCT REGISTRATION CARD should be filled in completely, signed and returned to Sure Heat Manufacturing.

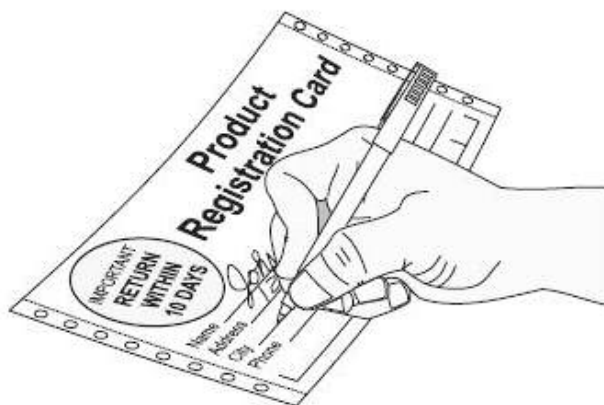

Please attach sales receipt here for future reference.

Please retain this manual for future reference

Amana™ is a registered trademark of the Maytag Corporation and is used under license to Sure Heat Manufacturing

General Safety Instructions

WARNING

Do not use the rotisserie in the rain.

WARNING

Electrical Grounding Instructions

This appliance (rotisserie motor) is equipped with a three-prong (grounding) plug for your protection against shock hazard and should be plugged directly into a properly grounded three-prong receptacle. Do not cut or remove the grounding prong from this plug.

WARNING

Keep any electrical supply cords and the fuel supply hose away from any heated surfaces.

WARNING

The Spare L.P. Gas Tank Barrier must be installed to prevent storage of spare L.P. Gas Tanks. Failure to comply with these instructions could result in a fire or explosion that could cause serious bodily injury, death, or property damage.

FOR YOUR SAFETY

If you smell gas:

1. Shut off gas to the appliance.
2. Extinguish any open flames.
3. Open grill hood.
4. If odor continues, immediately call your gas supplier and local Fire Dept.

WARNING

CALIFORNIA PROPOSITION 65 - WARNING: The Burning of gas cooking fuels generates some by products which are on the list of substances which are known by the State of California to cause cancer or reproductive harm. California law requires businesses to warn customers of potential exposure to such substances. To minimize exposure to these substances, always operate this unit according to the use and care manual, provide good ventilation when cooking with gas.

This appliance is not intended to be installed in or on recreational vehicles or boats.

WARNING

NOTE: Do Not operate the main burners and infrared back burner at the same time. This can cause warping of the roll top grill hood.

WARNING

Do not use the grill in garages, breezeways, sheds or any enclosed area. Never operate the grill in enclosed areas as this could lead to a carbon monoxide buildup, which could result in injury or death. Place the grill on a level surface. Avoid moving the grill while it is operation.

WARNING

Always have a qualified service technician perform difficult conversions or modifications.

WARNING

Never attach an unregulated gas line to the appliance. Connection to an unregulated gas line can cause excessive heat or fire.

TESTED IN ACCORDANCE WITH ANSI Z21.58b-2002/CSA 1.6b-M02 STANDARD FOR OUTDOOR COOKING GAS APPLIANCES. THIS GRILL IS FOR OUTDOOR USE ONLY.

Check your local building codes for the proper method of installation. In the absence of local codes, this unit should be installed in accordance with the National Fuel Gas Code No. Z223.1-2002 and the National Electrical Code ANSI/NFPA No. 70-1990

FOR YOUR SAFETY

DO NOT store or use gasoline or other flammable vapors and liquids in the vicinity of this or any other appliance.

An **LP cylinder** not connected for use shall not be stored in the vicinity of this or any other appliance.

WARNING

DO NOT try lighting this appliance without reading the "LIGHTING INSTRUCTIONS" section of this manual.

FOR OUTDOOR USE ONLY

SS 5 Grill Features



- | | |
|---------------------------------------|--|
| 1. Roll top grill hood | 9. Warming shelf |
| 2. Rotisserie kit | 10. Rear Infrared burner |
| 3. Grilling/cooking surface | 11. Side burner |
| 4. Side shelf | 12. Control knob: side burner |
| 5. Towel bar/utensil hanger | 13. Electronic igniter: main burners, side burner and rear infrared burner |
| 6. Control knob: Rear infrared burner | 14. Cart with doors |
| 7. Control knobs: main burners | |
| 8. Hood Handle | |

Getting Started

All hardware is shown actual size.



49600206 Caster Assembly Nuts x6



49600113 Self-Tapping Screws x13

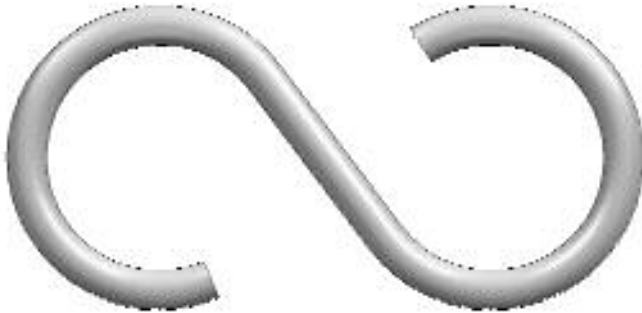

49600101 "S" Hooks x3

Two People Required to Assemble Grill

Tools Needed:

Phillips screwdriver

Adjustable wrench

1/2" wrench or socket

1/4" nut driver or socket

SS 5 Grill Out of Box

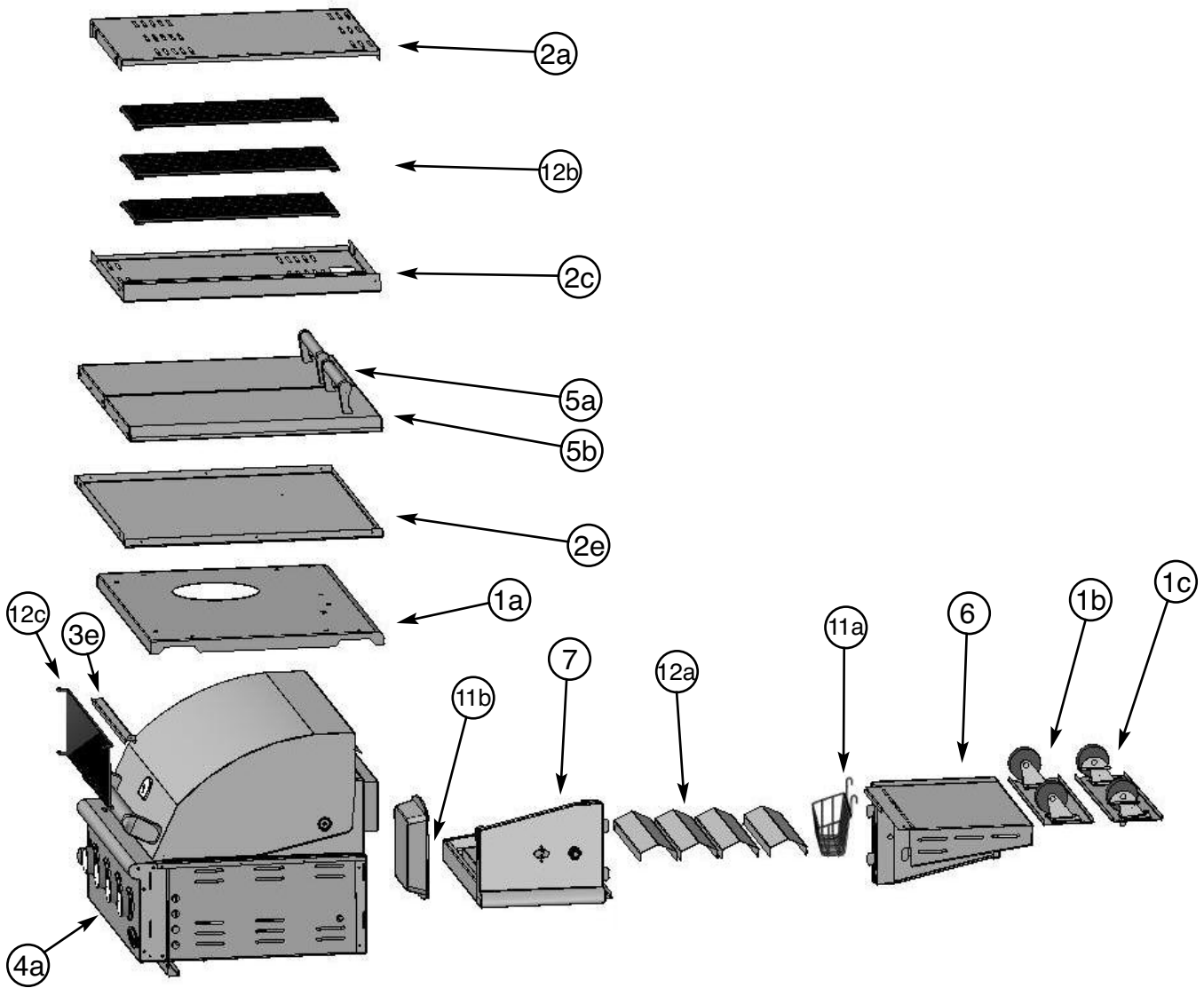

- 2a. Cart Side Left
- 12b. Main Cooking Grate
- 2c. Cart Side Right
- 5a. Cart Door Left
- 5b. Cart Door Right
- 2e. Cart Back
- 1a. Cart Base
- 12c. Bread Warmer Grate
- 3e. Spare LP Gas Tank Barrier
- 4a. Grill Assembly
- 11b. Drip Pan
- 7. Side Burner Shelf Assembly
- 12a. Flavor Grid

- 11a. Condiment Basket
- 6. Side Shelf Left Assembly
- 1b. Caster Assembly Left (Swivel Wheels)
- 1c. Caster Assembly Right (Swivel Wheel with lock)

Not Shown: Plastic bag containing:
 Igniter Wire
 Screw Packages
 Side Burner Igniter
 Side Burner Knob
 Side Burner Bezel
 Tank Ring

Open Box Carefully – Lay Out All Parts

SS 5 Assembly

STEP ONE

- a. Set the cart base on the floor and then lay the caster assembly left on the left side and the caster assembly right on the right side of the cart base. The large hole in the cart base will be towards the rear of the base.
- b. Pick up the left side of the cart base and set the caster assembly left in place by inserting the attached bolts through the three (3) holes in the cart base.
- c. Pick up the right side of the cart base and set the caster assembly right in place by inserting the attached bolts through the three (3) holes in the cart base.

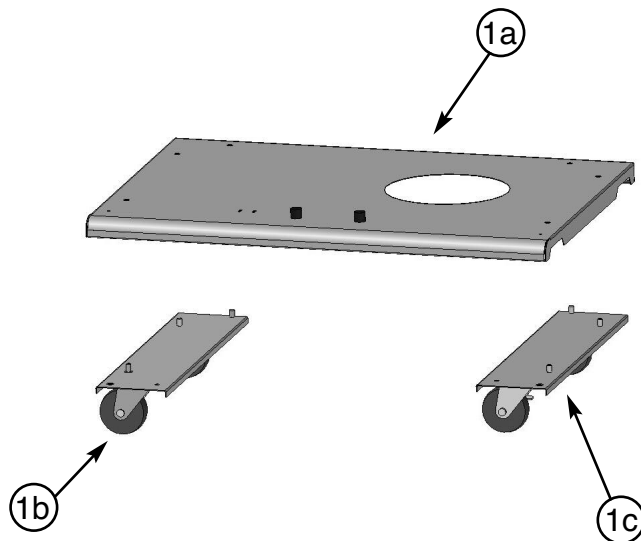

SS 5 Assembly

STEP TWO

- a. Place the cart side left onto the two (2) outer fixed caster assembly bolts, make sure the large flange is toward the front of the cart base.
- b. Secure the cart side left in place by hand tightening the caster assembly nuts onto the caster assembly bolts.
- c. Place the cart side right onto the two (2) outer swivel caster assembly bolts, make sure the large flange is toward the front of the cart base.
- d. Secure the cart side right in place by hand tightening nuts onto the caster assembly bolts.
- e. Place the cart back onto the two (2) rear caster assembly bolts.
- f. It will be necessary to push the top of the left and right cart sides outward slightly to get the cart back down completely on the cart base.

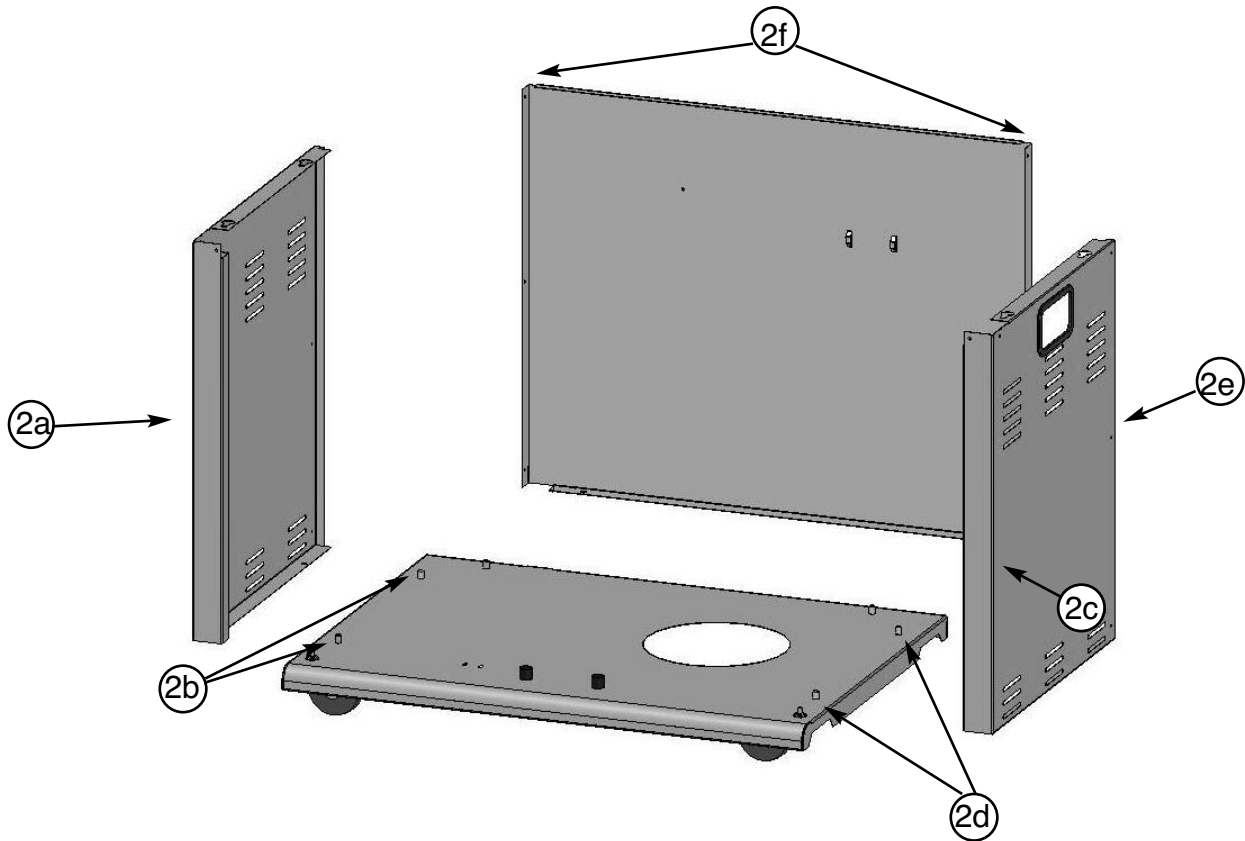

SS 5 Assembly

STEP THREE

- Press the cart sides back together making sure that the cart back flange cover the cart side flanges.
- Attach three (3) self tapping screws through the pre-drilled holes on the cart back into the cart side left. Repeat for cart side right.
- Fasten two (2) caster assembly nuts onto the back caster assembly bolts.
- Tighten all six (6) caster assembly nuts with a wrench.
- Attach the Spare L.P. Gas Tank Barrier by inserting the tabs into the slots in the cart base and then attach the flat end of the barrier to the pre-drilled hole in the cart back with a self-tapping screw.



WARNING The Spare L.P. Gas Tank Barrier must be installed to prevent storage of spare L.P. Gas Tanks. Failure to comply with these instructions could result in a fire or explosion that could cause serious bodily injury, death, or property damage.

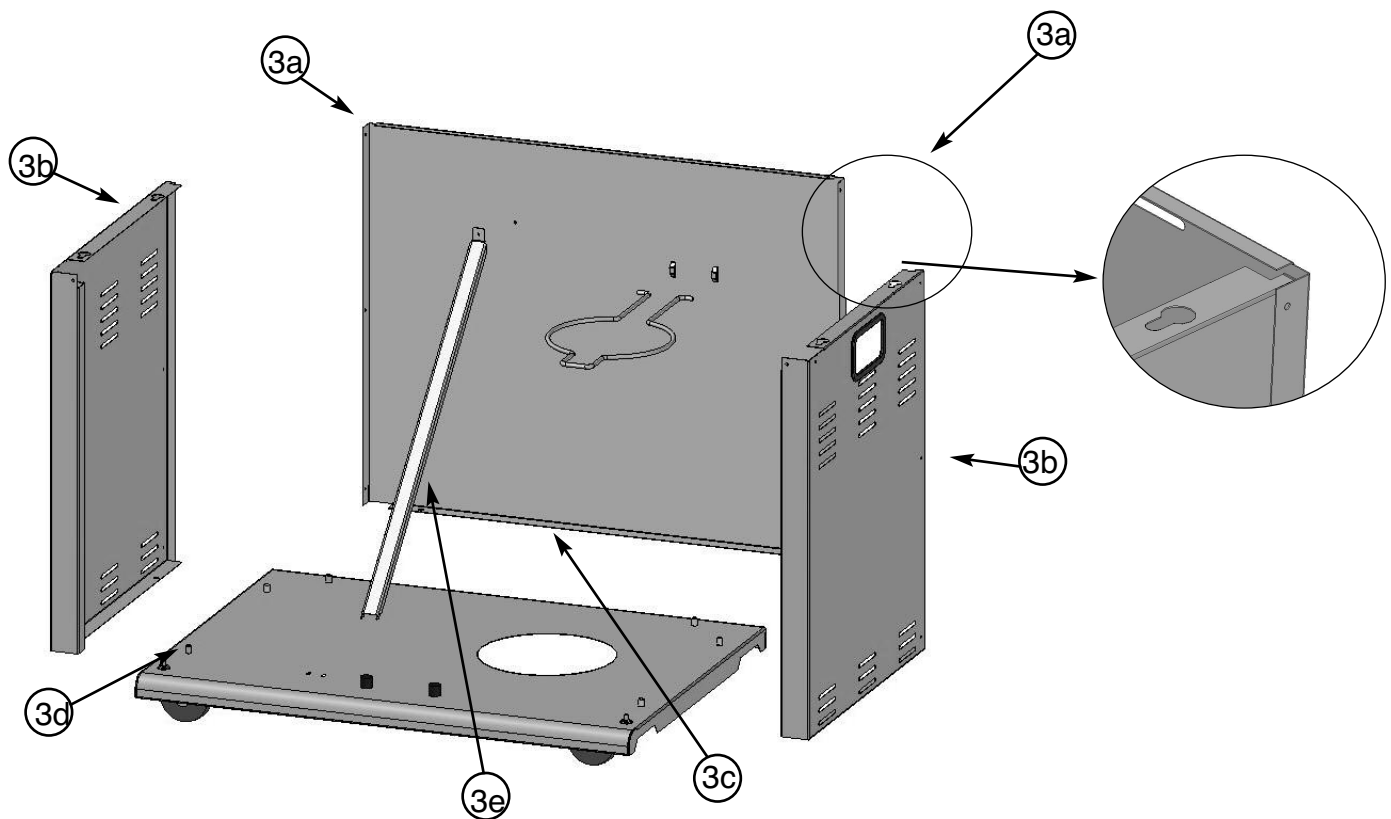

SS 5 Assembly

STEP FOUR

- Loosen the four (4) grill mounting bolts so that there is approximately 1/4" between the bolt head and grill bottom.
- Have someone help you pick up the grill and set it squarely on top of the cart.
- Make sure the four (4) bolts fall through the large opening on the "key hole" slots in the cart sides.
- Slide the grill forward in the "key hole" slots until the back of the grill head matches the cart back. Check on the inside of the cart to make sure that both sides of the grill are flush with the cart.
- Install two (2) self tapping screws into the top front and right cart flanges. Repeat on the left side.
- Tighten the four (4) grill head mounting bolts underneath the grill to secure the grill to the cart.

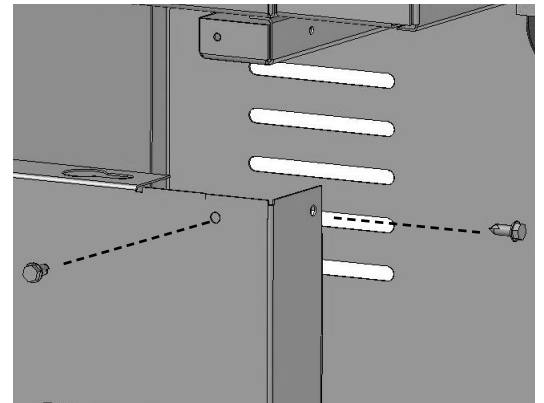
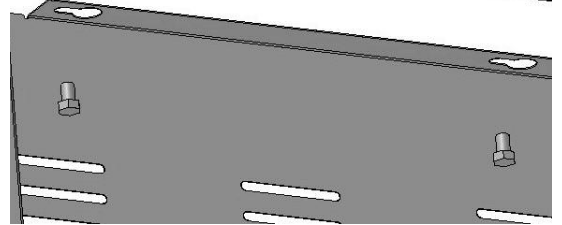
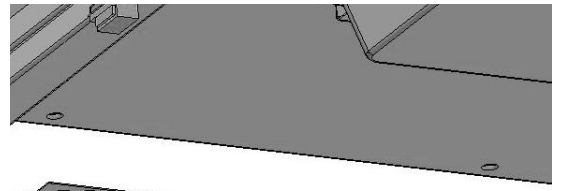

close-up steps 4c - 4f
Repeat for all 4 corners.

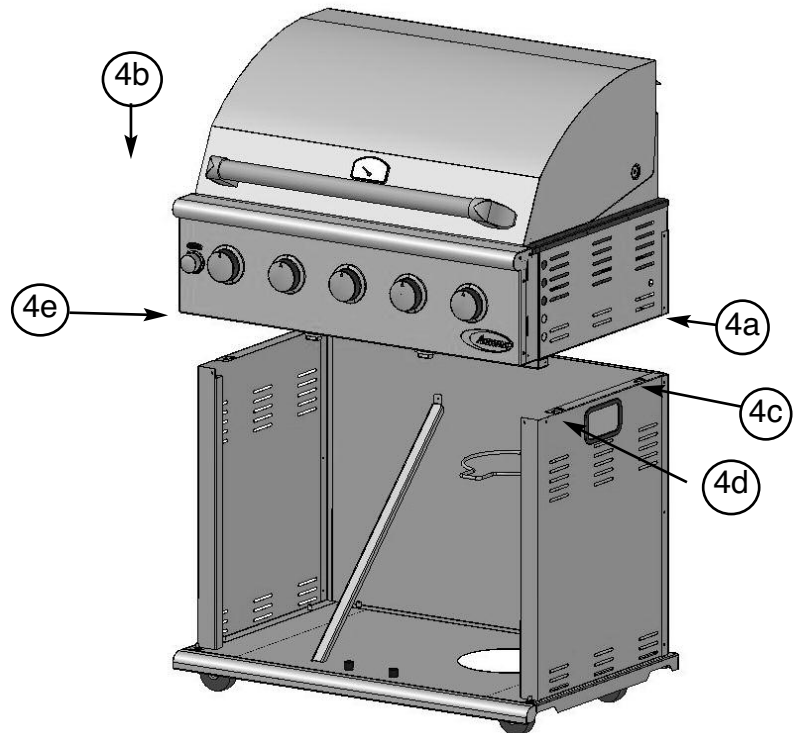

SS 5 Assembly

STEP FIVE

- a. Place cart door left on an angle over the left side door pivot.
- b. Tilt the top of the door toward the grill, while depressing the top door pivot pin above the door edge.
- c. Move the door slightly until the pin locks into place in the hole on bottom of the front face.
- d. Repeat steps 5a - 5c for cart door right installation.
- e. The levels of the doors may be adjusted using the nuts on the pivot points. You may need to remove a washer on the left or right hand door to make the doors align properly with each other.

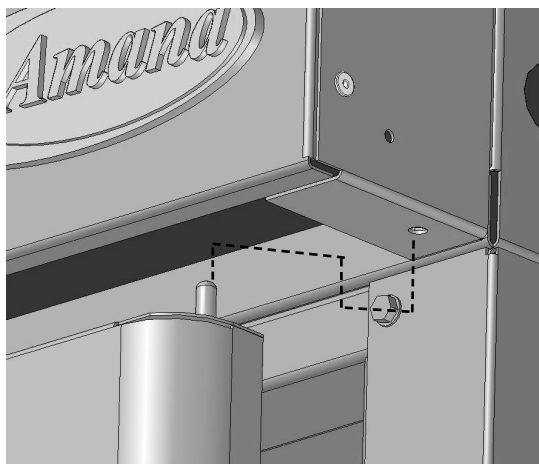

close-up of steps 5b - 5c

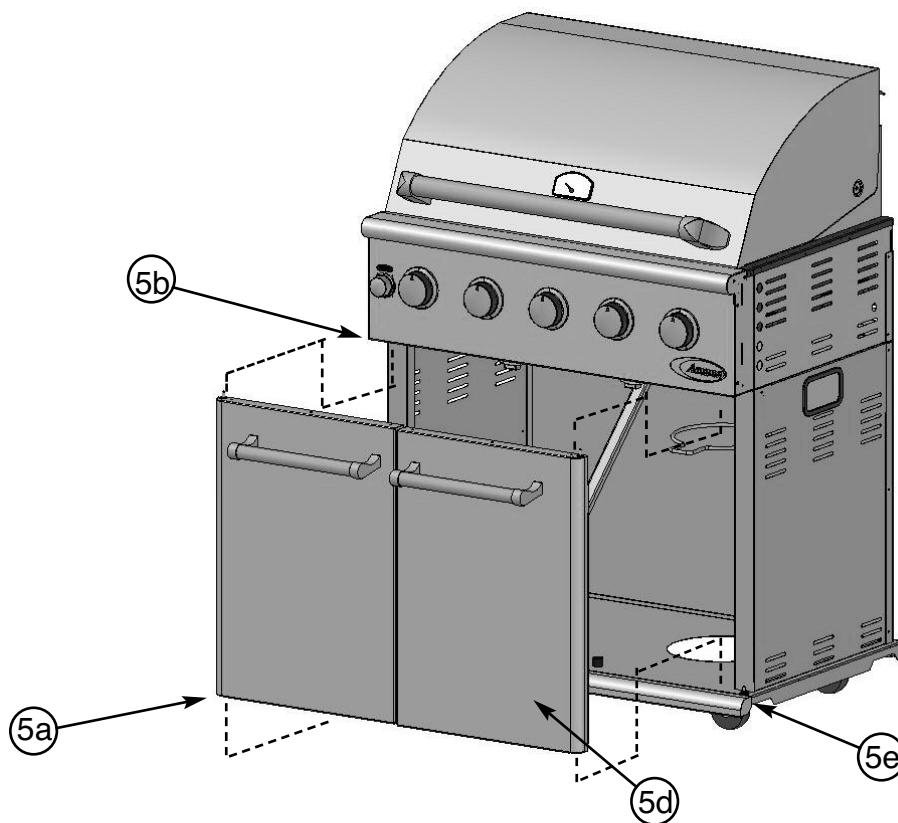

SS 5 Assembly

STEP SIX

- a. Lay the side shelf left assembly on its side with the shelf hooks facing up. With a Phillips head screwdriver, remove screw from handle end, and then attach one of the handle ends to the front of the shelf. **Note: Be careful not to scratch the side of the shelf.**
- b. Before you slide the towel bar into place, be sure to slide the "S" hooks over the bar. Then slide one end of the bar into the installed handle end. Attach the second handle end using the supplied phillips head screw while holding the assembly in place.
- c. Place a piece of styrofoam from the packaging inside the roll top grill hood to leave the hood propped open slightly.
- d. Attach the left shelf by inserting the four shelf hooks into the slots on the side of the grill.
- e. After inserting the four shelf hooks, press the shelf against the grill and press downward until the shelf locks in place. Make sure the top trim strip is hanging all the way inside of the grill before pressing downward.

f. Install one self tapping screw into the bottom front hole of the shelf. This will permanently lock the shelf in place.

g. Install one self tapping screw into the back hole on the shelf top. This will lock the shelf in place more stably.

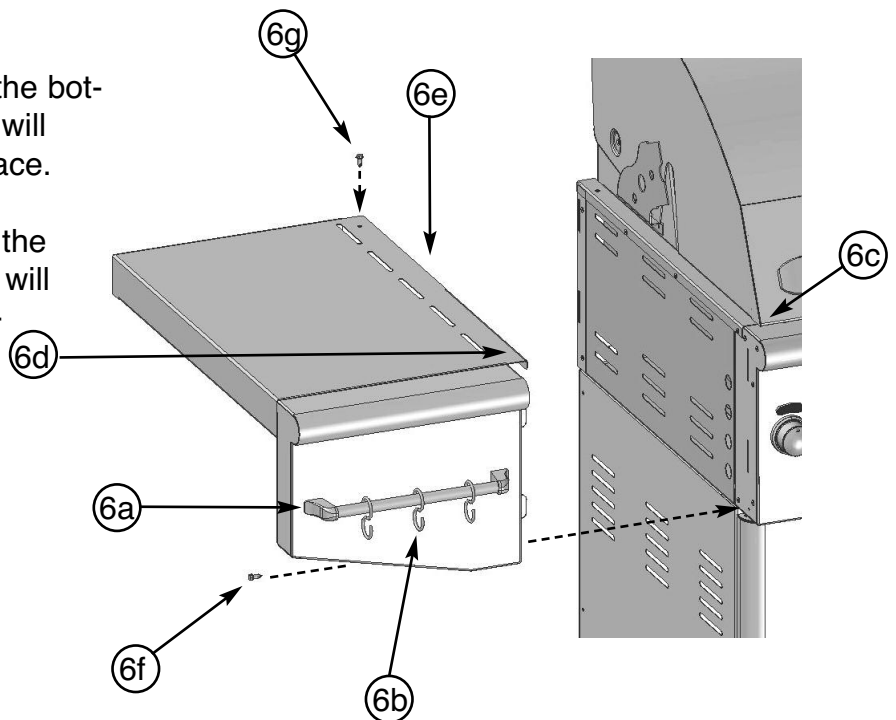

SS 5 Assembly

STEP SEVEN

- a. On the inside bottom of the side burner assembly you will find the brass burner cap attached with tape. Remove and set aside.
- b. Feed the side burner gas supply hose assembly through the grommeted hole in the side of the cart.
- c. Place a piece of styrofoam from the packaging in the roll top grill hood to leave the hood propped open slightly.
- d. Attach the right side burner shelf by inserting the four shelf hooks into the slots on the side of the grill.
- e. After inserting the four shelf hooks, press the shelf against the grill and press downward until the shelf locks in place. Make sure the top trim strip is all the way inside of the grill before pressing downward.
- f. Install one self tapping screw into the bottom front hole of the shelf. This will permanently lock the shelf in place.
- g. Install one self tapping screw into the back hole on the shelf top. This will lock the shelf in place more stably.

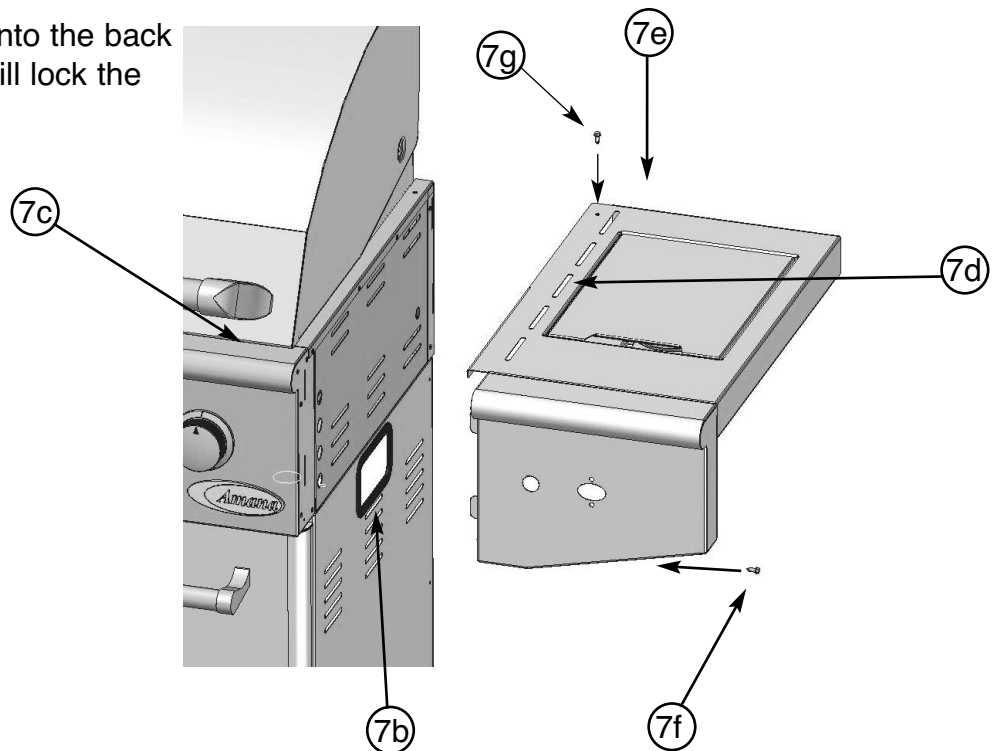

SS 5 Assembly

STEP EIGHT

- a. Remove two screws from the side burner valve assembly.
- b. Carefully insert the valve assembly into the cast side burner. You will need to angle the tube into the burner assembly. Make certain that the hose is pointing down when the valve is put in place. Then push the valve stem out through the opening in the front of the side burner shelf assembly, lining up the holes on the valve assembly with the holes on the side burner shelf.
- c. Place bezel into place, with the "off" position pointing up, making sure to line up holes.
- d. Attach bezel & valve to side burner shelf with screws removed in step 8a.
- e. Press knob onto valve stem assembly.

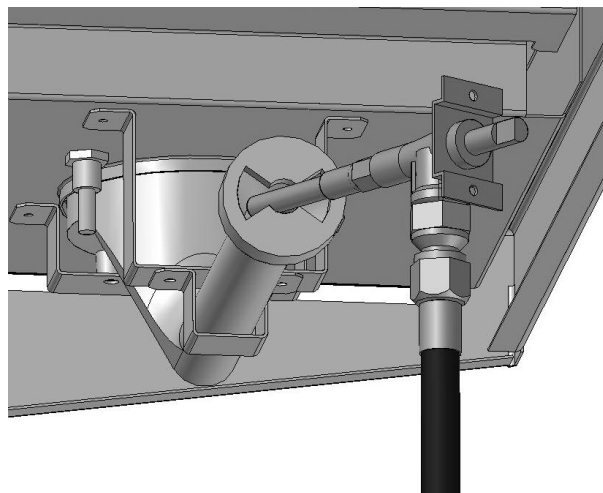

close-up of step 8b

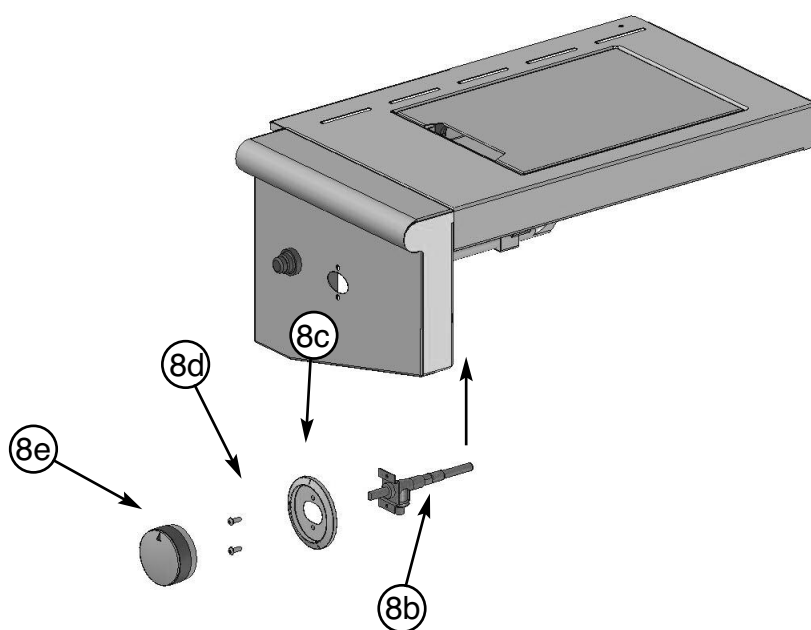

SS 5 Assembly

STEP NINE

- a. Attach loose wire to bottom of cast burner, and then to any of the open tabs in the igniter. Insert the four remaining igniter wires coming through the grommeted hole on side of the grill into the remaining tabs in the igniter.

Note: The igniter is designed in such a way that it does not matter which terminal tab is used when connecting igniter wires.

- b. Place the electronic igniter into the igniter hole on the front of the side burner shelf. Make certain that the igniter wire tabs are facing away from the grill.
- c. Secure the igniter in place using the plastic lock nut. Make sure to tighten securely.
- d. Install AA battery, negative side first.
- e. Install spring and cap assembly and tighten securely.

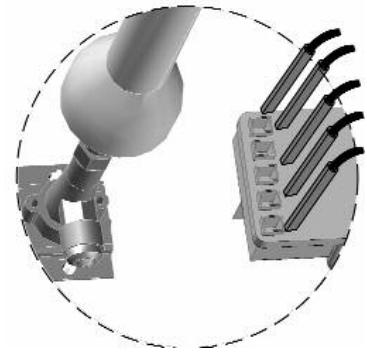

Close-up of igniter wires attaching to igniter.

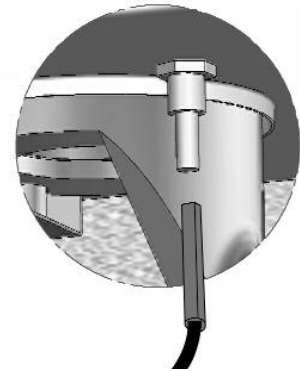

Close-up of igniter wire attaching to burner.

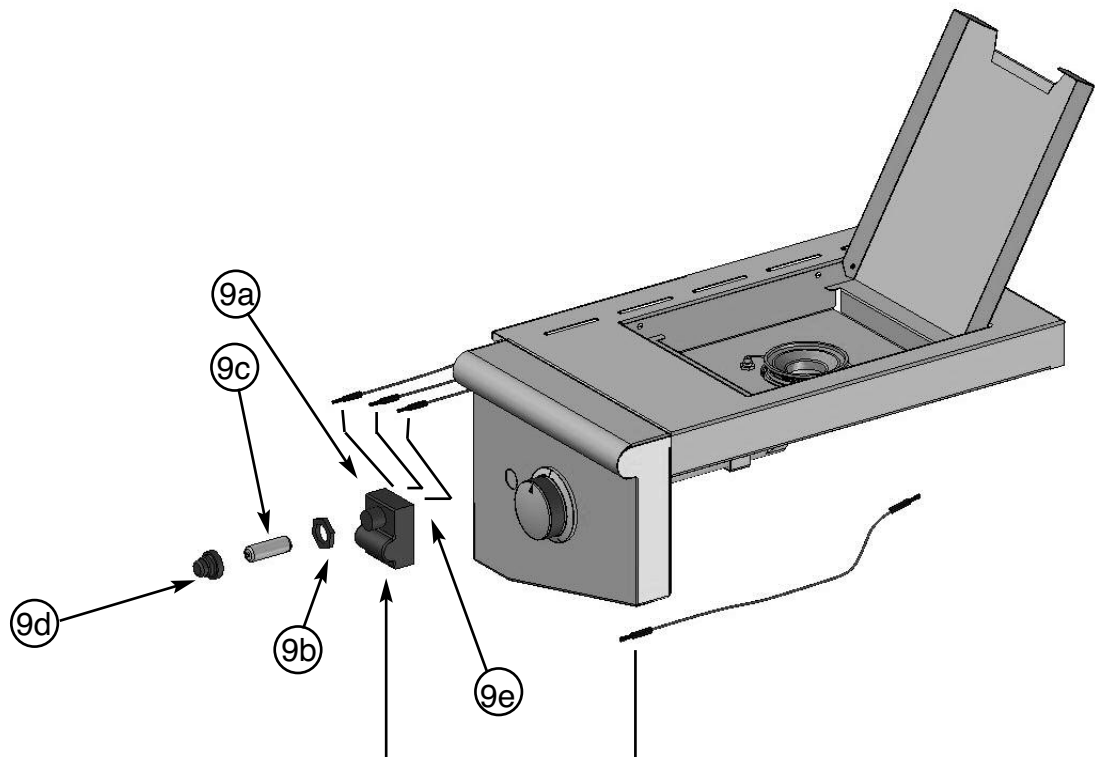

SS 5 Assembly

STEP TEN

- a. Center the brass burner cap on top of the side burner head.
- b. Place the side burner grate on to the side burner tray.

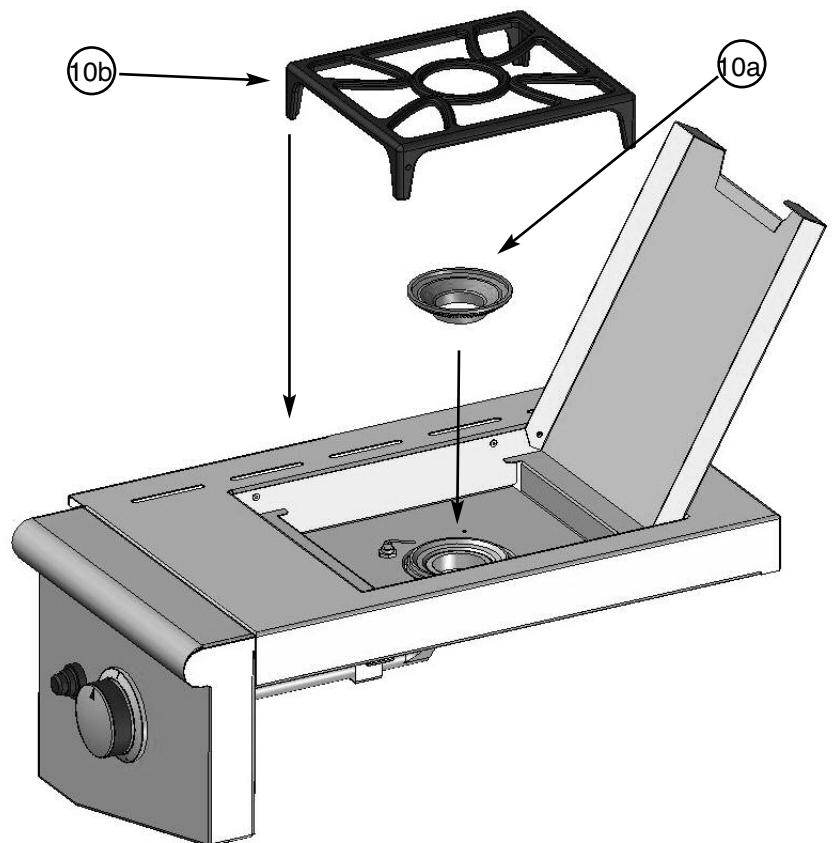

SS 5 Assembly

STEP ELEVEN

- a. Slide the condiment basket into the slots located inside of the left hand cart door.
- b. Slide drip pan in place.

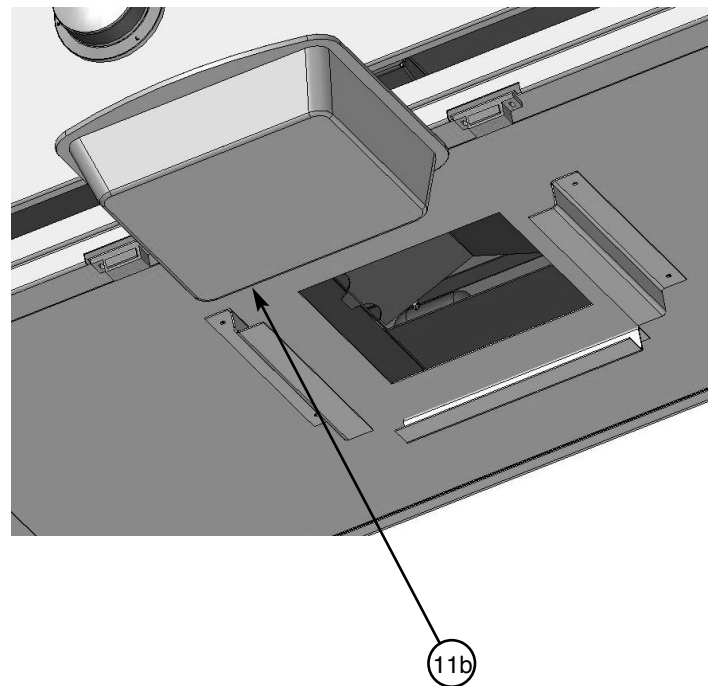
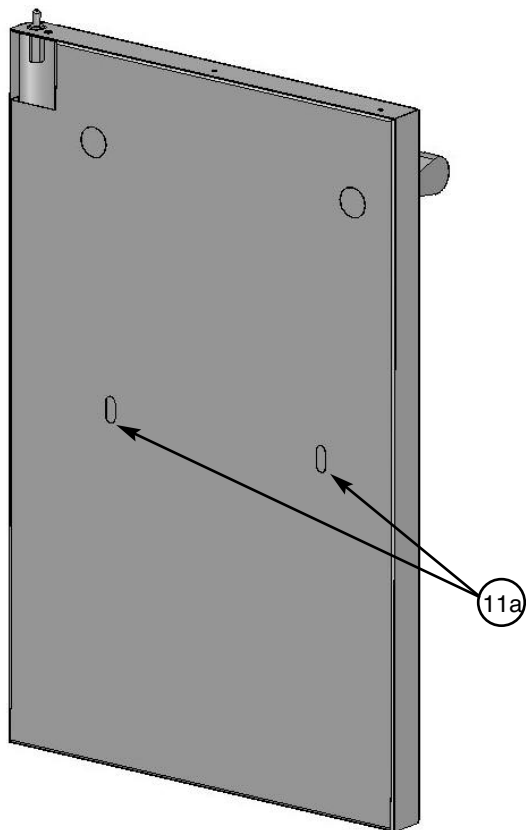

SS 5 Assembly

STEP TWELVE

- a. Insert the flavor grids into the cutouts with triangle ridges facing up.
- b. Install main cooking grates on the ledges provided on the grill to create your cooking surface.
- c. Rest bread warming grate on four (4) slots above cooking grid.

The finished grill should look like the photo on the cover of this Use and Care Manual. Clean the outside of the grill using only a soft cloth and non-abrasive soap and water or approved stainless steel cleaner.

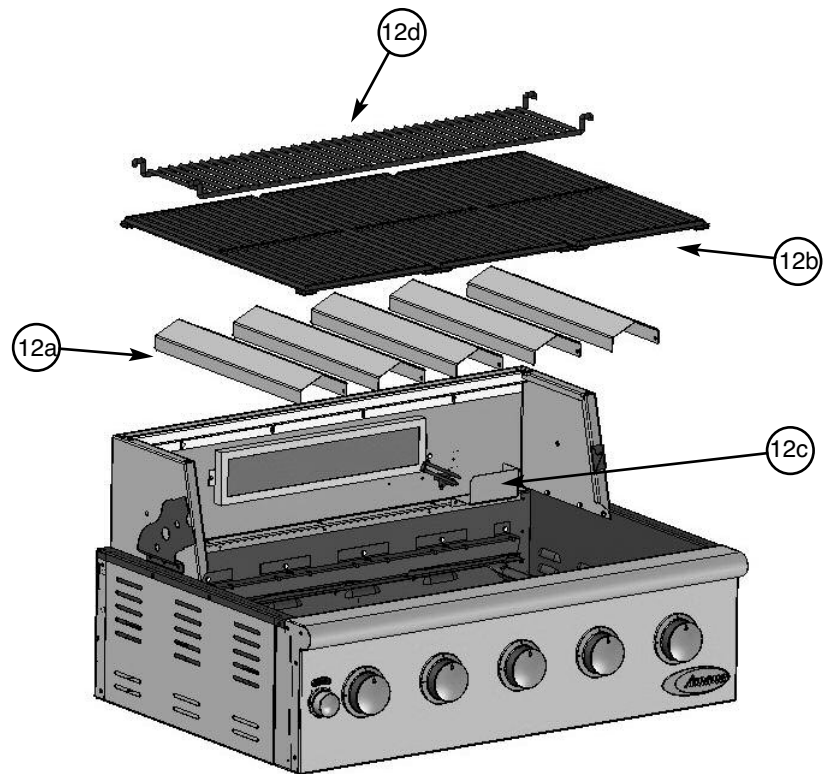

Gas Requirements

GENERAL INFORMATION

⚠ WARNING Never attach an unregulated gas line to the appliance. Connection to an unregulated gas line can cause excessive heat or fire.

Verify the type of gas supply to be used, either Natural Gas (N.G.) or Liquid Propane (L.P.), and make sure the serial plate agrees with that of the supply. Conversion kits are available separately for an additional cost which will enable you to convert your grill from L.P. to N.G. or to convert your grill from N.G. to L.P. Please see your local dealer for more information.

⚠ WARNING Always have a qualified service technician perform difficult conversions or modifications.

For natural gas installations, an installer must supply a gas shutoff valve that is easily accessible to the grill. All installer supplied parts must conform to local codes, or in the absence of local codes, with the National Electrical Code, ANSI/NFPA 70-1990, and the National Fuel Gas Code, ANSI Z223.1-1998.

All pipe sealants must be an approved type and resistant to the actions of L.P. gases. Never use pipe sealant on flare fittings. All gas connections should be made by a competent qualified service technician and in accordance with local codes and ordinances. In the absence of local codes, the installation must comply with the National Fuel Gas Code, ANSI Z223.1-1998. Gas conversions kits may be purchased separately. When ordering gas conversion kits, have the model number, and the type of gas (N.G. or L.P.) used for your grill.

This grill and its individual shut off valve must be disconnected from the gas supply piping system during any pressure testing of that system at test pressures in excess of 1/2 PSIG (3.5 kPa.).

This grill must be isolated from the gas supply piping system by closing its individual manual shut-off valve during any pressure testing of the gas supply piping system at test pressures equal to or less than 1/2 PSIG (3.5 kPa.).

The installation of this grill must conform with local codes, or in the absence of local codes, with National Fuel Code, ANSI Z223.1a-1998.

Installation in Canada must be in accordance with the Standard Can1-b149.1 and/or .2 (installation code for gas burning appliances and equipment) and local codes.

Gas Requirements

L.P. GAS INSTALLATION

Amana™ Gas Grills that are set to operate with L.P. gas come with a high capacity hose and regulator assembly. **(Note: Only use the pressure regulator and hose assembly supplied with the grill or a replacement pressure regulator and hose assemblies specified by Amana™).**

This assembly is designed to connect directly to a standard 20 lb. L.P. cylinder. L.P. Cylinders are not included with the grill. L.P. Cylinders can be purchased separately at an independent dealer.

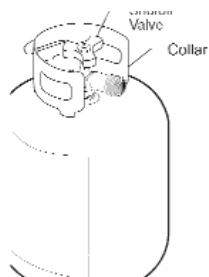

LP hose/
regulator supplied
with complete grill
and cart.

(Type 1
connector)



L.P. TANK INFORMATION

Never use a dented or rusted L.P. tank or cylinder with a damaged valve.

L.P. cylinders are equipped with an O.P.D (Overfilling Prevention Device). The device shuts off the flow of gas to a cylinder after 80% capacity is reached. This limits the potential for release of gas when the cylinder is heated, averting a fire or possible injury.

The L.P. cylinder must have a shut-off valve terminating in an L.P. gas supply cylinder outlet specified, as applicable, for connection No. 510 in the standard for compressed gas cylinder valve outlet and inlet connection ANSI/CSA-V-1. Cylinders must not be stored in a building, garage, or any other enclosed area. (The L.P. cylinder must have an overfill protection device, OPD, on it.)

The L.P. gas supply cylinder must be constructed and marked in accordance with the specifications for L.P. gas cylinders of the U.S. Department of Transportation (DOT) or the National Standard of Canada, CAN/CAS-B339, "Cylinders, Spheres and Tubes for the Transportation of Dangerous Goods."

L.P. TANK USE

- When turning the L.P. tank on, make sure to open the valve SLOWLY two (2) complete turns to insure proper gas flow. Most gas tanks now come equipped with a leak detector mechanism internal to the tank, when gas is allowed to escape rapidly it shuts off the gas supply. Opening the valve rapidly may simulate a gas leak, causing the safety device to activate, restricting gas flow causing low flames. Opening the valve slowly will insure this safety feature is not falsely triggered.
- When not in use, gas supply cylinder valve is to be in the "OFF" position.
- The tank supply system must be stored upright to allow for vapor withdrawal.
- The regulator and hose assembly must be inspected before each use of the grill. If there is excessive abrasion or wear or if the hose is cut, it must be replaced prior to the grill being used again.
- Cylinders must be stored outdoors out of the reach of children and must not be stored in a building, garage or any other enclosed area.
- Only a qualified gas supplier should refill the L.P. tank.
- Do not store a spare L.P. gas cylinder under or near the grill.

Pre Operation Leak Testing

GENERAL INFORMATION

Although all internal gas connections on the grill are leak tested prior to shipment, a complete gas tightness check must be performed at the installation site due to possible shifting during shipment, installation or excessive pressure unknowingly being applied to the unit. Periodically check the whole system for leaks and immediately check the system if the smell of gas is detected.

BEFORE TESTING

Do not smoke while leak testing. Extinguish all open flames. Never leak test with an open flame.

Mix a solution of equal parts mild detergent or liquid soap and water.

TESTING

1. Turn off the burner control knobs.
2. Turn the top knob of the fuel supply cylinder counterclockwise (right to left) two (2) rotations to open.
3. Apply the soap solution to connections of the fuel supply assembly. If no soap bubbles appear, there is no gas leak. If bubbles form at the connections, a leak is detected. If a leak is detected, immediately turn off the gas supply, tighten any leaking fittings, turn gas on, and repeat steps 1-3.
4. Turn off the knob on the fuel supply cylinder.
5. Turn on the burner control knobs for a moment to release the pressure in the hose, then turn the control knobs back off.
6. Wash off soapy solution with cold water and towel dry.

Check all gas supply fittings before each use and each time the gas supply cylinder is connected to the regulator.

Have a qualified service technician leak test the grill any time a part of the gas system is replaced.

Also it is recommended to perform a leak test at least once a year whether or not the L.P. gas supply cylinder has been disconnected.



NOTE: When leak testing this appliance, make sure to test and tighten all loose connections, including the side burner. A slight leak in the system can result in a low flame, or hazardous condition. Most L.P. gas tanks now come equipped with a leak detector mechanism internal to the tank, when gas is allowed to escape rapidly it shuts off the gas supply. A leak may significantly reduce the gas flow making the grill difficult to light or causing low flames.



NOTE: If you cannot stop a gas leak turn off the gas supply and call your local gas company or the dealer you purchased the appliance from. If necessary, replace the faulty part with the manufacturer's recommended replacement part. A slight leak could cause a fire.

Lighting the Grill

BEFORE LIGHTING

⚠ WARNING Important! Before Lighting:

- Check the gas supply line for cuts, wear or abrasion.
- Always keep your face and body as far away from the grill as possible when lighting.

GRILL BURNER LIGHTING

Lighting the Grill with electronic igniter

1. Make sure all control knobs are in the “ OFF” position.
2. Open the gas supply valve located on top of your L.P. tank.

ATTENTION: When turning the L.P. tank on, make sure to open the valve very **SLOWLY** two (2) complete turns to insure proper gas flow.

3. Always open the hood before attempting to light.
4. Push and turn one of the control knobs counter clockwise to the “ HIGH” position and immediately press the electronic igniter button. You will hear a snapping sound. It may be necessary to hold the electronic starter button for about 4 seconds. (See Fig. 50)

NOTE: If the burner does not light in 4 seconds, turn the knob to the “ OFF” position and wait 5 minutes before trying again.

5. Repeat above steps to light remaining burners.

MATCH LIGHTING

If by chance the electronic igniter does not light the burner, the burner may be lit with a match. Keep your face as far away from the grill surface as possible and place a lit, long stem match through the spaces in the grill grates to the ports of the back crossover

burner between the flavor grids. Position the match near the burner ports and push and turn the control knob counter clockwise to the “ HIGH” position. (See Fig. 51-52)

Note: If the grill will not light after several attempts see the trouble-shooting section of this manual. Turn the control knobs to the OFF position when not in use.

Do not attempt to “ Light” the grill if the odor of gas is present!!

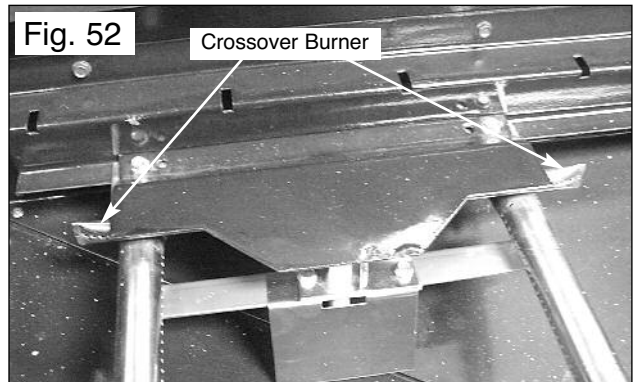

Using the Grill

GRILL LOCATION



Do not use the grill in garages, breezeways, sheds or any enclosed area. Never operate the grill in enclosed areas as this could lead to a carbon monoxide buildup, which could result in injury or death. Place the grill on a level surface. Avoid moving the grill while it is operation.

NOTE: The grill will operate best if it is not facing directly into the wind.

Clearance to combustible construction - A minimum of 12" from the sides and back must be maintained from the gas grill above and below the cooking surface to adjacent vertical combustible construction.

Clearance to non-combustible construction - A minimum of 6" clearance from the back of the grill to non-combustible construction is required for the lid to fully open.

Storage of an outdoor gas cooking appliance indoor is permissible only if the cylinder is disconnected and removed from the appliance.

GENERAL RULES

Do not leave the grill unattended while cooking!

1. Make sure the grill has been leak tested and is properly located.
2. Light the grill burners using the instructions provided in this manual.
3. Turn the control knobs to desired temperature " High, Medium, or Low" and preheat the grill for 10 minutes before cooking.
4. Adjust heat settings to meet your cooking needs for desired results.
5. Allow grill to cool down, wipe off any splatters or grease and clean the drip tray as needed.
6. Do not put a cover on the grill while it is still hot as it could start a fire.



Keep any electrical supply cords and the fuel supply hose away from any heated surfaces.

Using the Rotisserie

The grill rotisserie system is designed to cook items from the back using infrared heat. The rotisserie burner is an infrared type which provides intense searing radiant heat. Preferred by chefs over other cooking methods, this intense heat sears in the natural juices and nutrients found in quality cuts of meats.

Remove the warming rack from the grill when using the rotisserie to prevent warping from the intense heat of the infrared unit.

NOTE: The rotisserie spit rod is centered between the grill hood and the burners. It may be necessary to remove the grates and flavor grids when cooking larger portions of meat on the rotisserie. This is by design, since this configuration gives you the most possible room above and below the rod for larger pieces of meat.

Once lit, the rotisserie burner will reach cooking temperature in 1 minute. The orange/red glow will even out in about 5 minutes. The rotisserie motor is equipped with metal gears and is capable of turning up to 12 lbs. of food. The motor is mounted on a bracket on the left side of the grill by sliding the motor over the bracket with the cord facing the back of the grill. Make sure the rotisserie motor is completely seated on the bracket prior to operating. Make sure the rotisserie cord is away from any hot surfaces.



WARNING

Electrical Grounding Instructions

This appliance (rotisserie motor) is equipped with a three-prong (grounding) plug for your protection against shock hazard and should be plugged directly into a properly grounded three-prong receptacle. Do not cut or remove the grounding prong from this plug.

ATTACHING THE ROTISSERIE

The motor is mounted on a bracket on the left side of the grill by sliding the motor over the bracket with the cord facing the back of the grill. (See Fig. 53)

With the rotisserie motor in place and plugged into an electrical outlet, it is now ready to operate. Slide one of the meat forks onto the rod (prongs facing away from the rounded end). Push the rod through the center of the food, then slide the second meat fork onto the rod (prongs toward the food). Center the food to be cooked on the rod, then push the meat forks firmly together. Tighten the thumb screws. It may also be necessary to wrap food with butcher's string, (never use nylon or plastic string) to secure loose portions. (See Fig. 54)

Once the food is secure, insert the pointed end of the rotisserie rod into the motor assembly and rest the other end on the support on the right-hand side of the grill. (If needed, remove the cooking grates for more room). Turn the power switch to the "On" position to start the rotisserie motor.

NOTE: Remove the rotisserie when not in use. Store the unit indoors when not in use. Remove warming shelf when using rotisserie.

Fig. 53

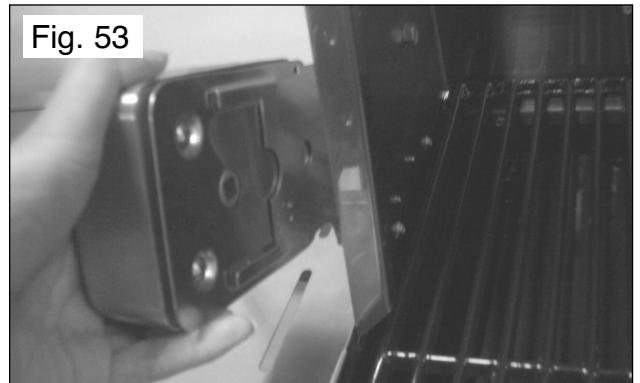
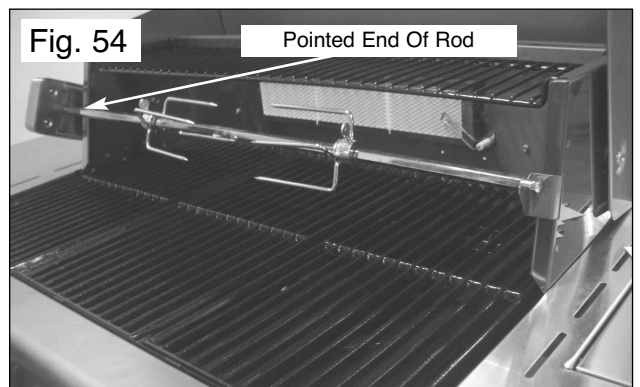

Fig. 54

Pointed End Of Rod



WARNING

Do not use the rotisserie in the rain.

Accessory Lighting

ROTISSERIE LIGHTING

Open the lid. Push and turn the control knob for the rotisserie counter clockwise to the “ HIGH” position. **Wait 5 seconds.** Then press and hold the electronic igniter button. You’ ll hear a snapping sound. If the burner does not light in 4 seconds, turn the control knob to OFF and wait 5 minutes before trying again. Once lit, turn the control knob to the desired setting. (See Fig. 55)

If the igniter does not function, the burner can be lit by holding a lit match to the burner while the control knob is turned counter clockwise to “ HIGH” . (See Fig. 56)

NOTE: After the first use the stainless steel around the burner will darken. This is a normal reaction of premium stainless steel to heat and is not a defect. The infrared panel will also darken after initial use. This is also a normal occurrence.

 **NOTE: Do Not operate the main burners and infrared back burner at the same time. This can cause warping of the roll top grill hood.**

SIDE BURNER LIGHTING

Push and turn the side burner control knob to the “ HIGH” position and immediately press and hold the electronic igniter button. You’ ll hear a snapping sound. It may be necessary to hold the electronic starter button for about 4 seconds. If the burner does not light in 4 seconds, turn the knob to the “ OFF” position and wait 5 minutes before trying again. Repeat above steps to light remaining burners. (See Fig. 57)

MATCH LIGHTING OF THE BURNER

If by chance the electronic igniter does not light the burner, the burner may be lit with a match. Keep your face as far away from the burner as possible and place a lit, long stem match through the spaces in the grate to the ports of the burner. Position the match near the burner ports and push and turn the control knob to the “ HIGH” position. (See Fig. 58)

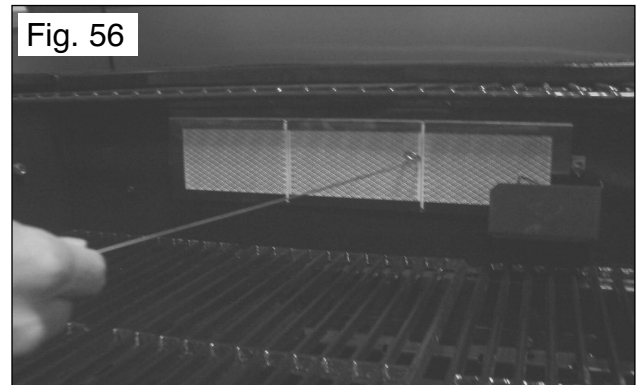

Care and Maintenance

DRIP TRAY

The drip tray located below the grill, inside the cart, should be cleaned periodically to prevent heavy buildup of debris.

Note: Allow the drip tray to cool before attempting to clean.

Important: Do not leave the grill outside during inclement weather unless it is covered (cover sold separately). Rain water can collect inside of the grill, the grill cart or the drip tray if left uncovered. If the drip tray is not cleaned after use and the grill is left uncovered, the drip tray will fill with water causing grease and water to spill into the grill cart. We recommend cleaning and storing the drip tray after every use.

COOKING GRATES

The cooking grates can be cleaned immediately after cooking is completed and after turning off the grill. Wear a barbecue mitt and scrub the cooking grates with a damp cloth. If the grill is allowed to cool down, cleaning the grates will be easier if removed from the grill and cleaned with a mild detergent.

STAINLESS STEEL

After initial usage, areas of the grill may discolor from the intense heat given off by the burners, this is normal.

Purchase a mild stainless steel cleaner and rub in the direction of the grain of the metal. Specks of grease can gather on the surface of the stainless steel and bake on to the surface and give a worn appearance. For removal, use a non-abrasive oven cleaner in conjunction with a stainless cleaner.

Note: Always scrub in the direction of the grain.

Note: Always keep your grill covered when not in use.

IGNITER ACCESS (UNDER SIDE BURNER SHELF)

To remove igniter, unscrew igniter push button and locking nut from front panel of the side burner and igniter will fall out through the bottom



REAR INFRARED BURNER

Light and burn the rear infrared burner at least once a month to ensure there is not a build-up of debris or grease on the burner. This will ensure the ceramic burner will continue to operate as it should.

PORCELAIN PARTS

Certain parts of your Grill have a porcelain coating. Porcelain is a glass-based product, and is highly durable to standard wear and tear. However, porcelain is sensitive to concussive blows, which can create interlaced micro-fractures, or “spider-webs.” Please take care not to strike any porcelain covered parts with solid objects, drop them, or create any other concussive blows. These interlaced micro-fractures are common and may lead to minor chipping. Neither the chipping nor the interlaced micro-fractures will adversely affect the performance or your grill, and are not covered under the warranty for porcelain parts.

Troubleshooting Your Grill

GENERAL TROUBLE SHOOTING

You should inspect the burners at least once a year or immediately if any of the following conditions occur:

- The smell of gas.
- Flames appearing mostly yellow. (some yellow at the tips is OK)
- The grill will not get hot enough.
- Burners make a snapping noise.
- The grill heats unevenly.

SPIDER AND INSECT WARNING

Spider and insects can nest in the burners of this or any other grill and cause the gas to flow from the front of the burner. This is very dangerous condition which can cause a fire to occur behind the valve panel, thereby damaging the grill and making it unsafe to operate. We recommend you check the grill and remove any spiders, insects and webs at least once a year to reduce this risk.

BEFORE CALLING CUSTOMER SERVICE

If the grill does not function properly, use the following checklist.

PROBLEM

Grill will not light when the igniter button is pushed.

SOLUTION

Is your gas supply turned on ?

If this is an L.P. grill, is there gas in your tank ? Check your gas level.

Is one of your burners turned on? Allow up to four seconds of gas flow to ignite.

Is your igniter working?

- You should hear a snapping sound when you press the igniter?
- If you hear a snapping sound can you see a spark at the electrodes?

Note - You will need to remove your cooking grates and flavor grids to see the electrodes.

Check to see if your igniter battery is installed correctly with the negative side in.

Check your igniter battery and replace if needed.

Check for loose wire connections to the igniter or electrodes.

Check to see if debris is blocking the electrodes.

If the igniter is not working can you light the grill with a match?

Troubleshooting Your Grill

PROBLEM

Grill will not light with a match or low heat with dial set to "High" position.

SOLUTION

- Is your gas supply fully turned on?
- If this is an L.P. grill is there gas in your tank ? Check your gas level.
- If this is an L.P. grill, shut off gas supply, disconnect gas line at tank, reconnect the line to the tank.
- Make sure all the knobs are in the off position, then open the gas supply valve on the L.P. tank very slowly 1/4 turn, then open fully (at least two full turns). Check flame height again.
- Check to insure the gas supply line or hose is not kinked.
- If only one burner appears low, check and clean the burner ports if clogged or dirty.
- Check for leaks.

Note - Pre-Heating time can take from 5 to 10 minutes.

Flame is erratic

- Check gas connection
 - look for kinked hose.
 - make sure gas supply valve is fully open.
- Gas level may be low.
- Grill may be in need of cleaning.

Flare-ups

- Check flavor grids and cooking grates for excess food or grease build-up.
- Ensure grill is not placed directly in the path of wind.
- Be sure drip tray is clean, (do not use aluminum foil on drip tray.)

Note: Some flare-ups may be inevitable if cooking greasy foods.

Burner flame is mostly yellow or orange, possibly in conjunction with smell of gas.

- Check the burner inlet for obstructions. Particularly at air inlets for each burner.
- Grill may be in an area that is too windy.

Cart door does not align properly with cart

- Loosen the four 1/2" bolts under the grill hood that hold grill to cart. Slide grill head left or right as needed until door is aligned properly. Retighten bolts.

WARNING: Move grill head gently to the left or right on the cart! After the four bolts have been loosened, the grill is not attached to the cart and could fall, causing damage or physical injury.

SS 5 Replacement Parts Sheet

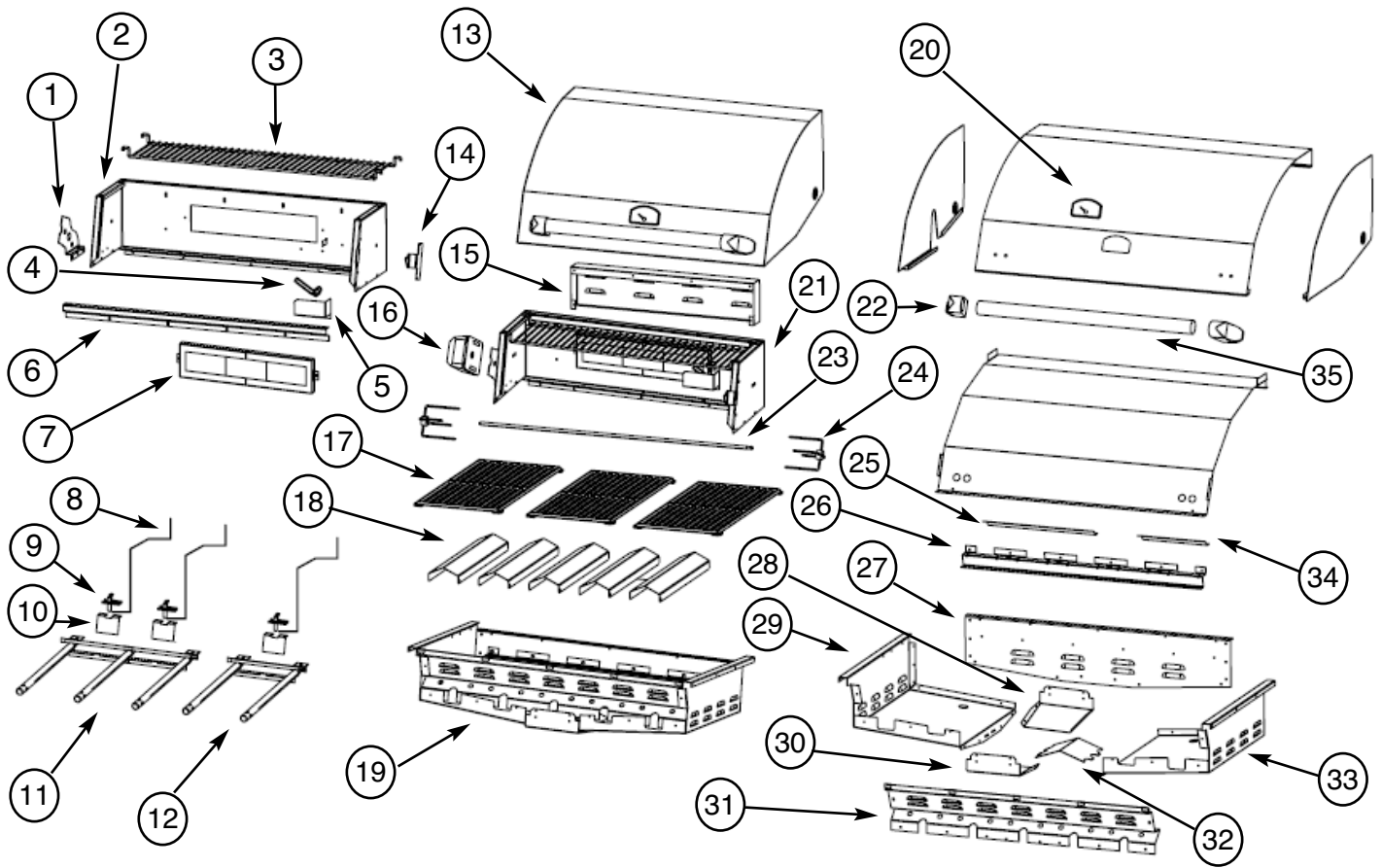

- NS* Bag of 13 Self-Tapping Screws
- NS* Bag of 6 Wheel Channel Nuts
- NS* Set of 3 " S" Hooks
- NS* Condiment Basket
- NS* Match Extender
- NS* Side Burner Igniter Wire
- NS* Back IR Igniter Wire
- NS* Hood Bolt Assembly
- 1. Rotis Motor Mount
- 2. Hood Support
- 3. Bread Warmer
- 4. Back IR Igniter
- 5. Back IR Igniter Cover
- 6. Back IR Heat Deflector
- 7. Back Infrared Burner
- 8. Main Igniter Wire Set
- 8a. Main Igniter Wire 36"
- 8b. Main Igniter Wire 42"
- 8c. Main Igniter Wire 48"
- 9. Main Igniter Spit Holder
- 10. Igniter Grease Shield
- 11. 3 Cell Burner
- 12. 2 Cell Burner

- 13. Hood Assembly
- 14. Spit Holder
- 15. Back IR Cover
- 16. Rotis Motor
- 17. TG 33 Main Grate
- 18. Flavor Grid
- 19. TG 33 Inner Liner Assembly
- 20. Dome Temp Gauge
- 21. Hood Support Assembly
- 22. Main Hood Handle End
- 23. TG 33 Spit Rod
- 24. Meat Fork
- 25. 3 Burner Z Bar
- 26. Burner Support
- 27. TG 33 Inner Liner - Back
- 28. TG 33 Inner Liner - Bottom
- 29. TG 33 Inner Liner Left
- 30. TG 33 Inner Liner - Bottom
- 31. Front Heat Shield
- 32. Drip Pan Heat Shield
- 33. TG Inner Liner Right
- 34. 2 Burner Z Bar
- 35. AL 30" - 1.5" x 24" Handle Tube

* Not Shown

SS 5 Replacement Parts Sheet

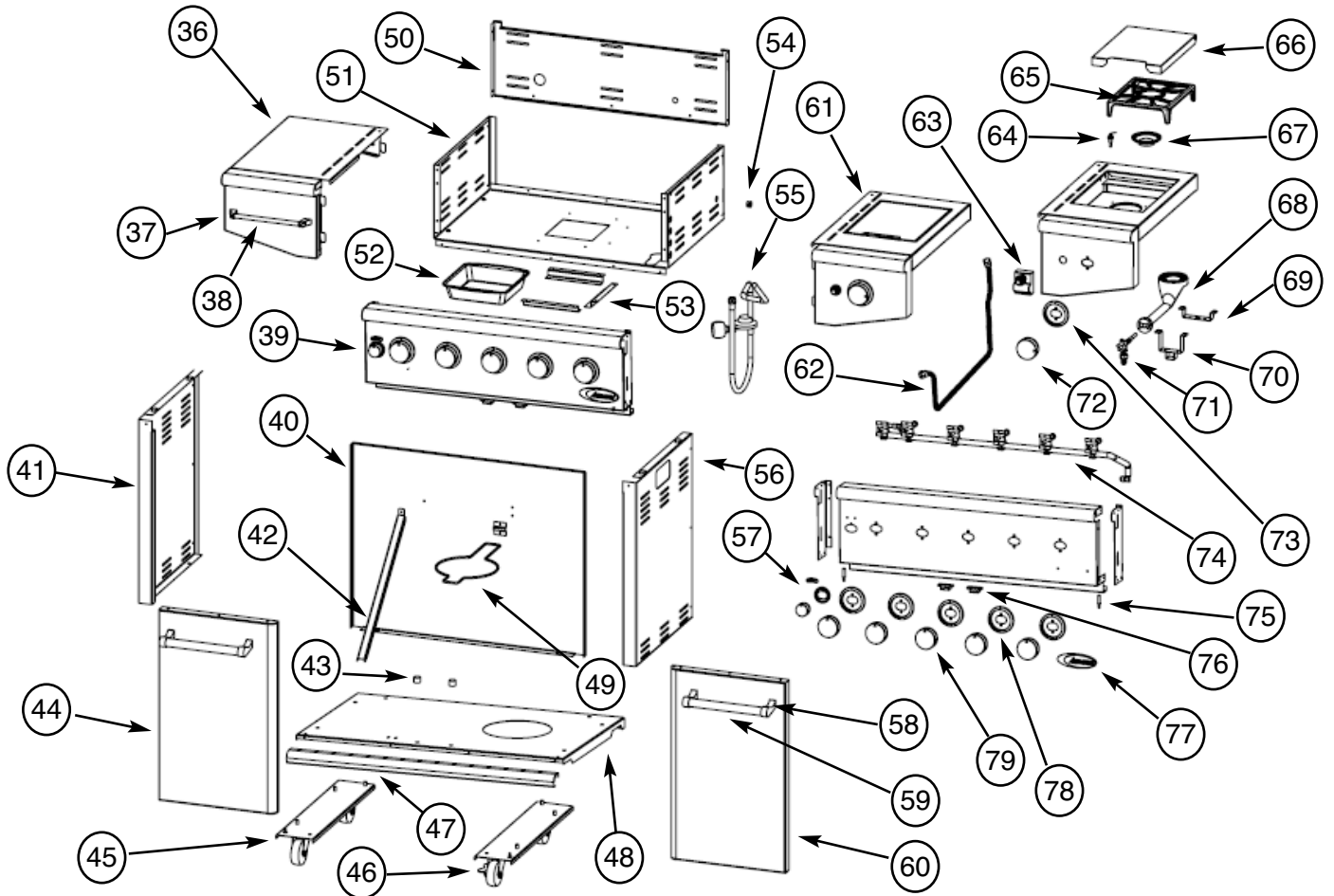

- | | | | |
|------|------------------------------|-----|---------------------------------|
| 36. | Side Shelf Left Assembly | 58. | 1" Handle End - Small |
| 37. | 1/2" Handle End - Small | 59. | 1" SST Tube - TG Door Handle |
| 38. | Towel Rack Tube | 60. | TG 33 Door Assembly Right |
| 39. | TG33 Front Face Assembly | 61. | Side Burner Shelf Assembly |
| 40. | TG33 Cart Back | 62. | Back IR Gas Line |
| 41. | Cart Side Left | 63. | 5 Pole Igniter |
| 42. | Cart Brace | 64. | Side Burner Igniter |
| 43. | Bottom Door Stop | 65. | Side Burner Grate (Cast Burner) |
| 44. | TG 33 Door Assembly Left | 66. | Side Burner Cover |
| 45. | Wheel Channel Assembly Left | 67. | Side Burner Cap (Cast Burner) |
| 46. | Wheel Channel Assembly Right | 68. | Cast Side Burner Assembly |
| 47. | Cart Base Front Trim | 69. | Rear Side Burner Bracket |
| 48. | Cart Base | 70. | Front Side Burner Bracket |
| 49. | Tank Secure Ring | 71. | Side Burner Valve (Cast Burner) |
| 50. | Grill Head Back | 72. | Main Burner Knob |
| 51. | Grill Head Bottom | 73. | Main Burner Bezel |
| 52. | Drip Pan | 74. | TG 33 Main Manifold Assembly |
| 53. | Drip Pan Guide | 75. | Door Spring Pin |
| 54. | Small Plastic Grommet | 76. | Magnetic Catch |
| 55. | 2-Hose Regulator Assembly | 77. | Amana Logo |
| 56. | Cart Side Right | 78. | Main Burner Bezel |
| 57a. | Back IR Knob | 79. | Main Burner Knob |
| 57b. | Back IR Bezel | | |
| 57c. | Back IR Nameplate | | |

Warranty

LIMITED WARRANTY

Sure Heat Mfg warrants that for the lifetime of the product from the date of purchase, the stainless steel panels will not break due to defects in material or workmanship, and that for a period of four years from the date of purchase, the stainless steel burners will be free from defects in material and workmanship. All other components of this barbecue grill are warranted free from defects in material and workmanship for one year from the date of purchase. Sure Heat Mfg, at its option, will repair or replace this product or any component of the product found to be defective during the warranty period. Replacement will be made with a new manufactured or remanufactured product or component. If the product is no longer available, replacement may be made with a similar product of equal value. This is your exclusive warranty.

This warranty is valid for the original retail purchaser from the date of initial retail purchase and is not transferable. Keep the original sales receipt. Proof of purchase is required to obtain warranty parts.

This warranty does not cover normal wear of parts such as scratches and dents of the stainless steel components or damage resulting from any of the following:

- negligent use or misuse of the product, including exposing the product to chemicals or cleaning products not approved by Sure Heat Mfg
- corrosion or discoloring due to lack of maintenance, misuse, hostile environments, alterations, accidents, or abuse or neglect
- use or installation contrary to specified instructions and applicable building codes, including heating the product to temperatures above its rated specifications which can cause considerable warping
- disassembly, including removal of the product from a built-in installation
- damage resulting from accident, alteration, misuse, abuse, hostile environments, or improper installation
- repair or alteration
- acts of God, such as fire, flood, hurricanes, and tornadoes
- gas cylinders, propane tanks or other fuel delivery systems, including connections to a household fuel supply
- usage other than single-family household use such as commercial or industrial use
- minor warping or discoloration of parts, which is normal and not a defect under this warranty

This warranty does not include transportation or shipping costs of any kind.
DO NOT RETURN THIS PRODUCT TO THE PLACE OF PURCHASE.

If the Sonoma Platinum Edition Grill does not operate properly, first thoroughly carry out the instructions provided with the unit to ensure that the appliance is installed correctly and check the troubleshooting section in the use and care manual.

We recommend you return the warranty registration card so that you can be contacted with any questions of safety arise that could affect you. The return of the warranty registration card is not a condition for warranty coverage.

If you have other questions, please contact Customer Service Hotline (800) 229-5647

Because of continuing product improvement these specifications are subject to change without notice.

Manufactured by Sure Heat

51021107

09/14/2006