

This Owner's Manual is provided and hosted by [Appliance Factory Parts](#).



# Centro 85-1142-4 (2006) Owner's Manual

[Shop genuine replacement parts for Centro 85-1142-4  
\(2006\)](#)



[Find Your Centro Grill Parts - Select From 150 Models](#)

----- Manual continues below -----



# Preparation Station

SAFE USE, CARE AND ASSEMBLY MANUAL

---

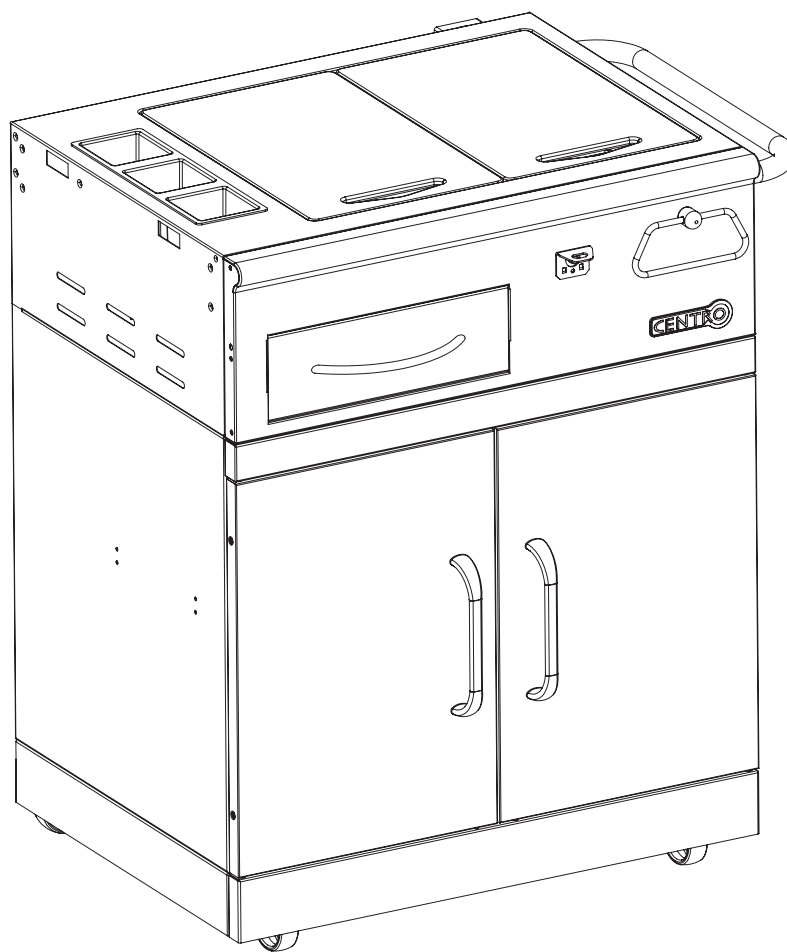

1-YEAR LIMITED WARRANTY

85-1142-4 (A01101)

Read and save this manual for future reference. If pre-assembled, leave this manual with unit for consumer's future reference.

For product inquiries, parts, and warranty, please call

**1-877-707-5463**

## TABLE OF CONTENTS

Warranty . . . . .	ii
Important . . . . .	1
Warnings . . . . .	1
Care and Maintenance. . . . .	1
Parts List and . . . . .	2-3
Parts Diagram	
Assembly Instructions . . . . .	4-8

## WARRANTY

**DO NOT RETURN TO STORE FOR PRODUCT INQUIRIES, PARTS OR WARRANTY. Please call toll-free 1-877-707-5463 for immediate customer service.**

### For Best Results

Remove all contents from packaging, and make sure all parts are present before attempting assembly. Tighten all bolts by hand first, then when the cart is fully assembled, go back and tighten.

### One-year Limited Warranty

This Centro product carries a one-year limited warranty against defects in workmanship and materials, when assembled and used in accordance with the instructions in this manual. Trileaf Distribution requires proof of purchase to provide immediate service. Please keep your sales receipt with this manual.

This Limited Warranty is for replacement of defective parts only. Trileaf Distribution reserves the right to have its representatives inspect any product of part prior to honouring any warranty claim.

**This limited warranty does not cover damage due to porcelain chipping, scratching of stainless steel surfaces, nor does it cover corrosion or discoloration due to misuse, lack of maintenance, fires, hostile environments, accidents, alterations, abuse or neglect, improper installation and failure to read and/or abide by any product warnings. Part failure due to lack of cleaning and maintenance, or use of improper cleaners will not be covered under this warranty. This limited warranty does not cover any damage sustained during removal and/or storage of this product. Please see the CARE AND MAINTENANCE SECTION FOR MORE INFORMATION.**

This limited warranty is nontransferable and becomes void if used for commercial or rental purposes. Should this product become defective within the stated warranty period, **do not return to store, but call 1-877-707-5463**

**Purchaser:** By accepting delivery of this product, the purchaser hereby accepts the foregoing and expressly waives any other remedy and damages, direct, indirect, and consequential.

---

## IMPORTANT

**Do not** use if temperature falls below 0C (32F). Periodically check all hardware and plastic parts for wear. Adjust or replace parts as needed. Please keep all plastic pieces out of the reach of small children. Please retain these instructions for future reference. **Please keep sales receipt for proof of purchase.**

---

## WARNINGS

- Please keep all assembly hardware, tools and packaging away from children.
  - Dispose of unused parts and their packages promptly.
  - Do not allow children to play in or around product.
  - Weight limit for bottom shelf is 30 lb (13 kg).
  - Weight limit for the counter top and cooler shelf is 20 lb (9 kg).
  - Weight limit for the towel rack is 5 lb (2.2 kg) and
  - If you intend to use this product for food preparation, please clean thoroughly before and after each use.
  - Remove service tray and cutting boards when not in use and store indoors.
- 

## CARE AND MAINTENANCE

Do not use abrasive cleaners to clean any painted, porcelain or stainless steel parts. Exterior surfaces should be cleaned with warm soapy water, and dried thoroughly.

To protect against corrosion and discoloration please read the following.

Stainless Steel performs best when clean- cleanliness is essential for maximum resistance to corrosion. There are various practices for cleaning stainless Steel in use. This includes methods for removing free-iron contamination on stainless Steel surfaces. The salt air environment of coastal areas or a high humidity environment can be corrosive to Stainless Steel finishes. These conditions can cause rusting. Other contaminants include dirt, debris, residue from cleaners (many cleaners contain corrosive ingredients which require thorough post clean rinsing with clean water) or other material, hinders the passivation process and traps corrosive agents to the stainless steel, reducing corrosion protection. Routine cleaning is necessary to preserve and protect the appearance and integrity of the surface.

To clean stainless Steel surfaces, use a soft cloth and clean warm water to remove mild stains and loose dirt. Other cleaning agents include a stainless steel cleaner, a non-abrasive, chloride free, non-acidic cleaner, or simply a vinegar and water solution. Always wipe in the direction of the grain and ensure that the unit is dried thoroughly after cleaning. DO not use steel wool, as it will scratch the finish.

**PARTS LIST****85-1142-4 (A01101)**

<b>Item No.</b>	<b>Quantity</b>	<b>Specification</b>	<b>Part No.</b>
A	1	Cooler Cover	A006-0012-01
B	1	Cooler Assembly	A006-1000-01
C	1	Container A	A011-0018-01
D	1	Upper Bracket F/ Umbrella	A011-0500-01
E	1	Rear Brace	A011-0001-01
F	1	Drawer Bar	A A011-0009-01
G	1	Drawer Bar B	A011-0010-01
H	1	Condiment Box	A011-0005-01
I	1	Cooler Set	A006-0001-01
J	2	Chopping Board	A011-0006-01
K	1	Top Board Assembly	A011-0017-01
L	1	Towel Bar Set	G602-0022-02
M	1	Front Panel Assembly	A011-2100-01N
N	1	Back Panel	A011-0012-01P
O	1	Lower Bracket F/ Umbrella	A011-0011-01R
P	1	Drawer Assembly	A011-3000-01T
Q	1	Upper Front Brace	A011-4000-01V
R	1	Left Side Panel Assembly	A011-0200-01X
S	1	Right Side Panel Assembly	A011-0300-01Z
T	1	Bracket F/ Container B	A011-0013-01BB
U	2	Container B	A011-0014-01
V	1	Bottom Shelf Assembly	A011-0400-01
W	1	Left Door Assembly	G415-8000-01
X	1	Right Door Assembly	G415-9000-01
Y	2	Door Handle	G413-0016-01
Z	1	Cooler Bracket Assembly	A006-2200-01
AA	2	Caster Assembly	G401-0062-01
BB	2	Caster Assembly W/ Lock	G401-0061-01
CC	2	Joint Hook	A011-0039-01

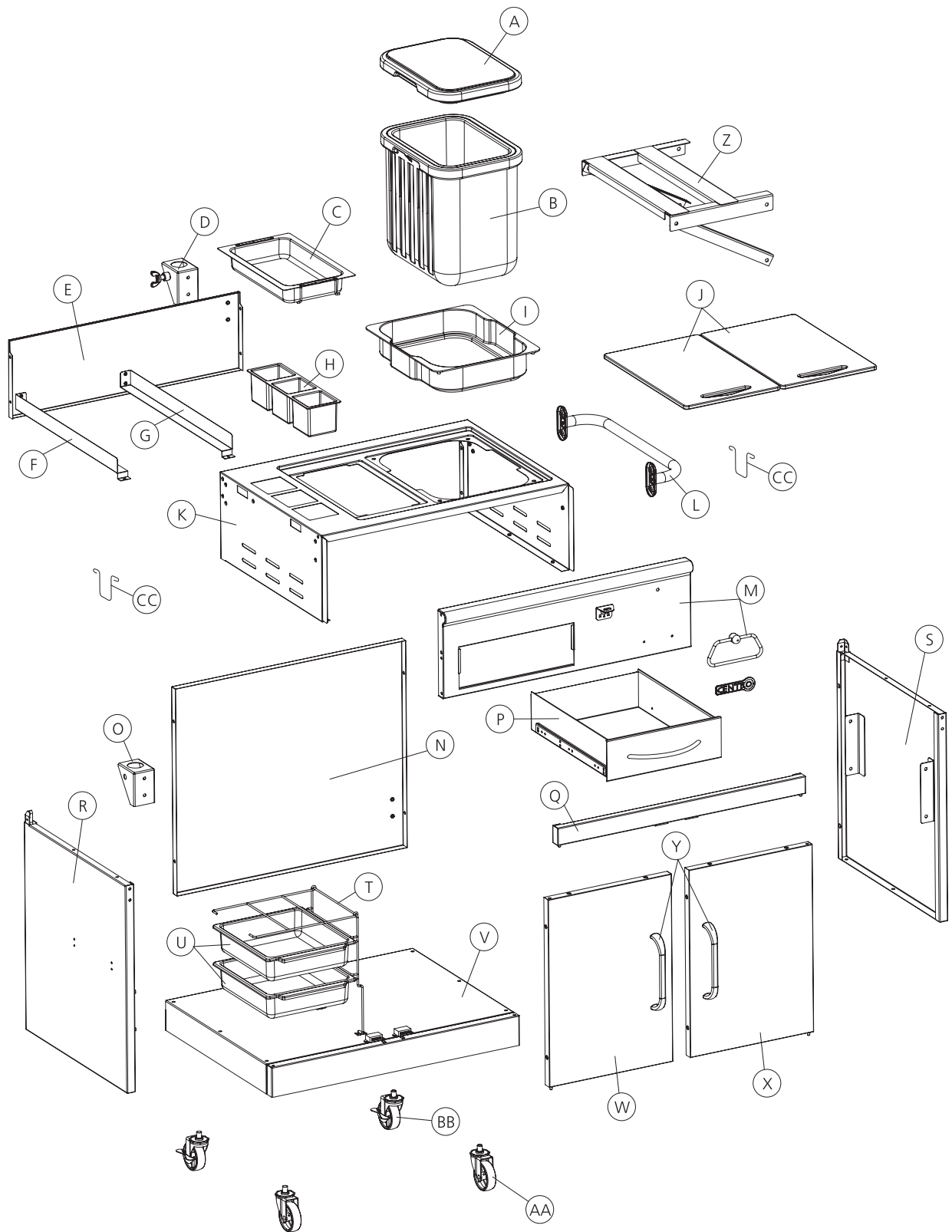

## ASSEMBLY INSTRUCTIONS

### Tools Needed for Assembly

- Hammer
- #3 Phillips® screwdriver
- Slotted screwdriver
- Safety glasses

Before assembling the cart, read these instructions carefully. Assemble the cart on a flat, clean surface.

**Notes: Do not** fully tighten all the nuts during this initial stage.

You may have extra hardware after assembly is complete.

### Hardware Pack List

No.	Description	Part Number	Quantity
1	1/4-20 UNCx13 Screw	20120-13013-250	22
2	Ø7 Lock Washer	41400-07000-250	22
3	Ø7 Washer	40300-07000-250	22
4	1/4" - 20 UNC NUT	30220-13000-250	10
5	NO.10-24 UNC x 10 Screw	20124-10010-250	10
6	Ø5 Lock Washer	41400-05000-250	10
7	Ø5 Washer	40300-05000-250	10
8	WRENCH	G401-0071-0182	1

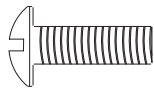

#1 – 1/4" x 13 mm Screw ( x 22)



#4 – 1/4" Nut (x10)

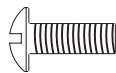

#5 – No.10 x 10 Screw (x10)

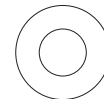

#7 – Ø5 Flat Washer (x10)

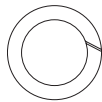

#3 – Ø7 Washer (x22)

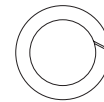

#2 – Ø7 Lock Washer (x22)



#6 – Ø5 Lock Washer (x10)

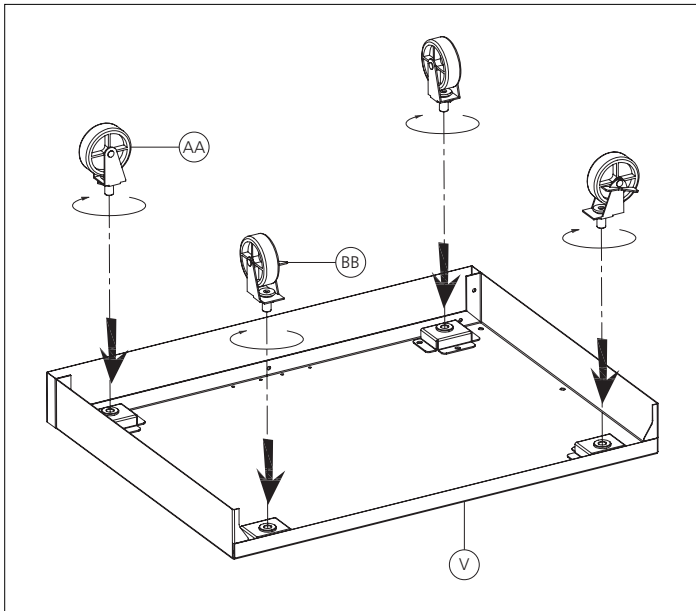

# 1

Assemble two front casters (AA) and back casters with lock (BB) to the bottom Shelf (V) as shown.

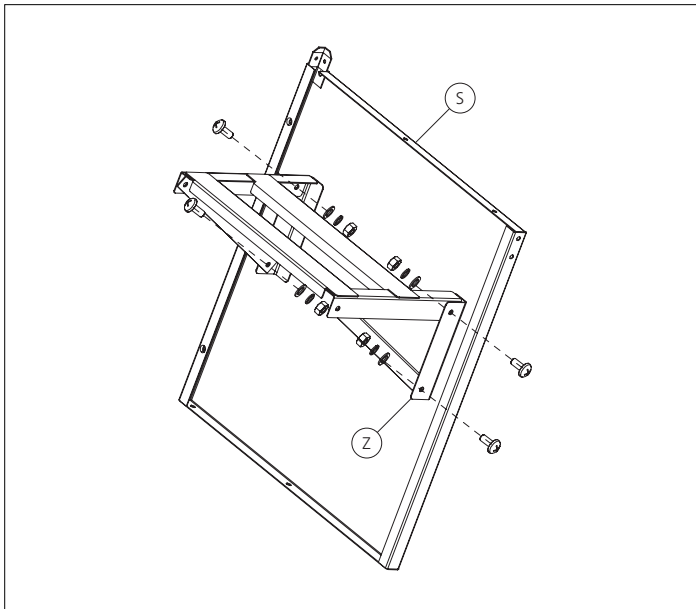

# 2

Assemble the cooler box bracket (Z) to the right side panel (S) using hardware #1, #2, #3, and #4 (x4) as shown.

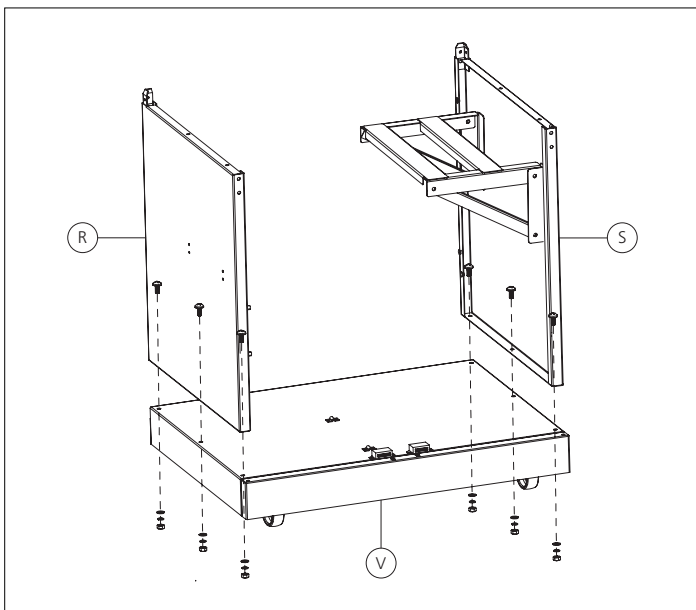

# 3

Assemble both right and left side panel (R & S) to the bottom shelf using hardware #1, #2, #3, and #4 (x6)



# 4

Assemble the back panel (N) on the inside of the cart. Assembly as shown using hardware #1, #2, and #3 (x4).

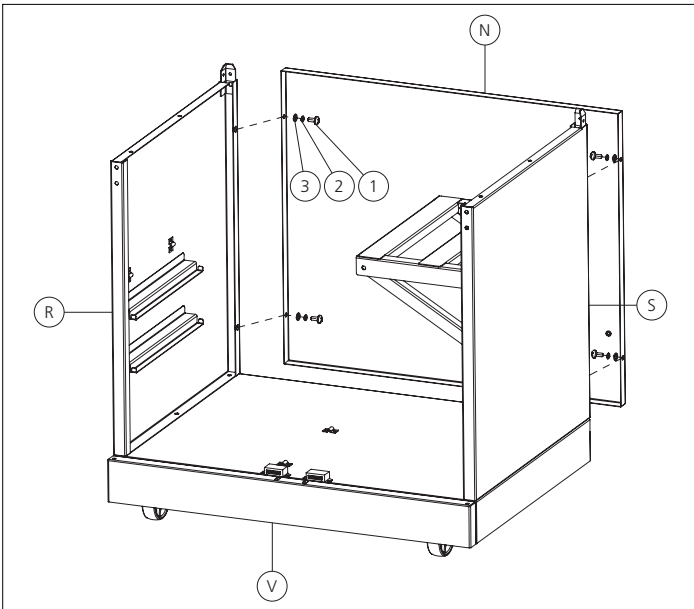

# 5

Assemble the upper front brace (Q) to the front of the cart assembly using hardware #5, #6, and #7 (x4).

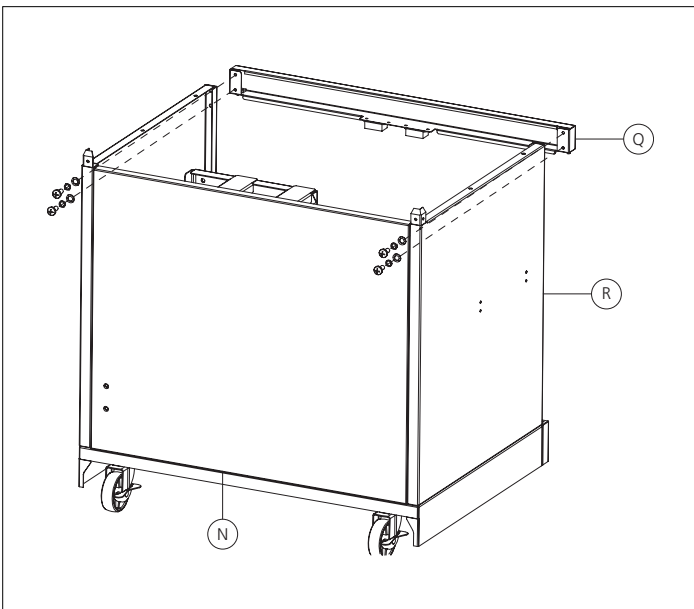

# 6

Place the top board assembly (K) to the cart assembly.

Affix them using hardware #5, #6, and #7 (x4) through the bottom. And use hardware #5, #6, and #7 (x2) through the back as shown.

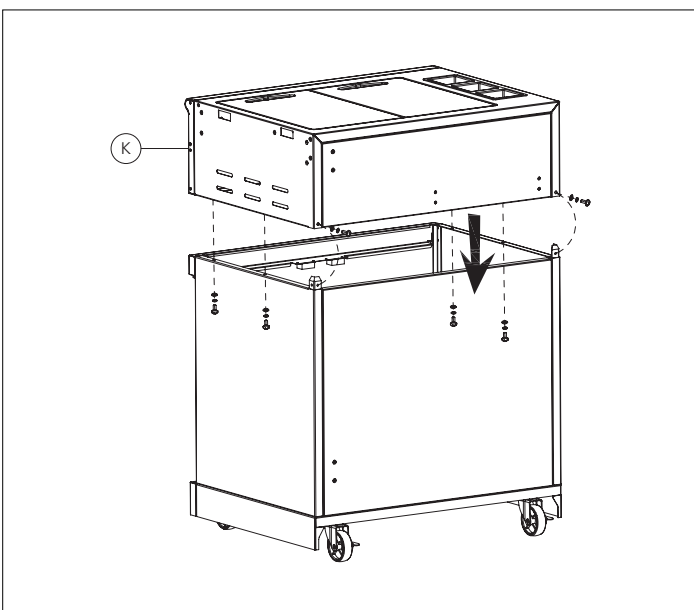

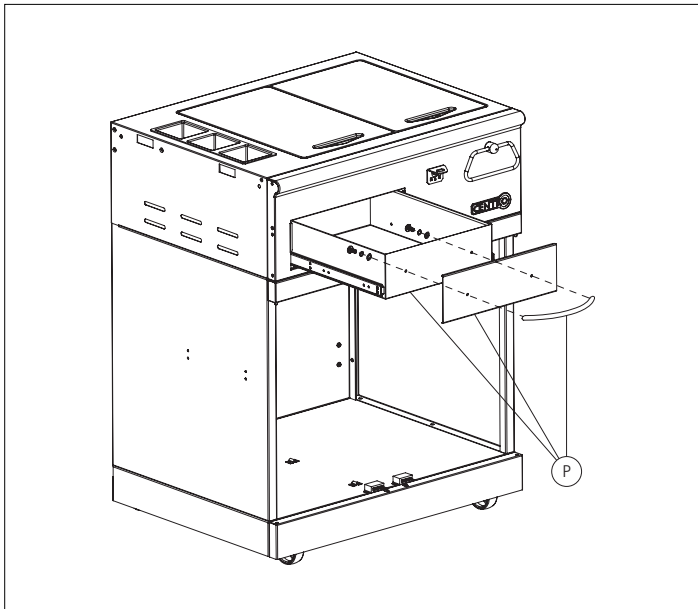

# 7

Remove the screws and nuts from the drawer handle (P) and then assemble the handle, drawer box, and drawer front panel together using the hardware removed from the handle.

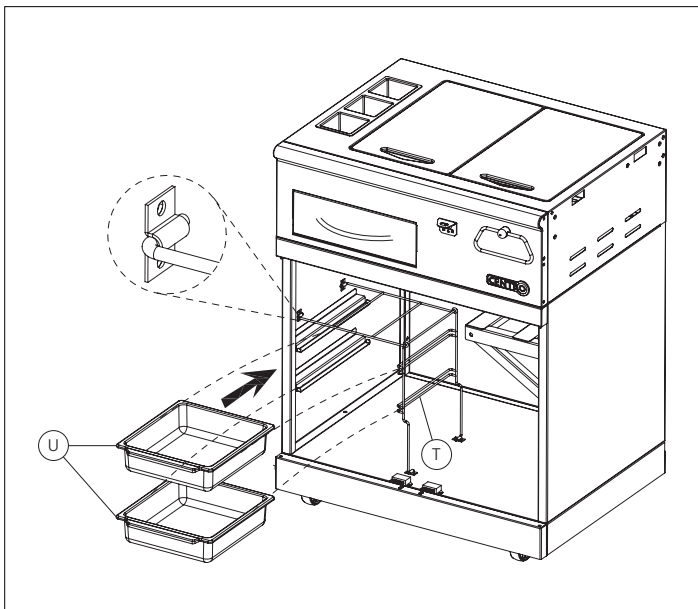

# 8

Attach the cart tray bracket (T) into the cart as shown. Insert two trays (U) into the bracket (T) as shown.

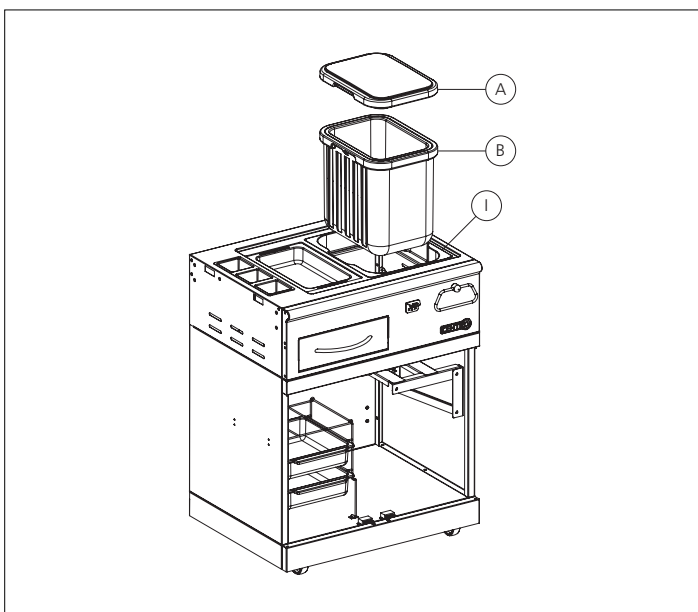

# 9

Place the cooler box (B) and the cooler box cover (A) into the cart from the top as shown.

# 10

Assemble the left and right door (W & X) into the cart as shown.

Remove the screw and nuts from the door handles (Y) and assemble the handles to the doors (W & X) by using hardware removed from the handle.

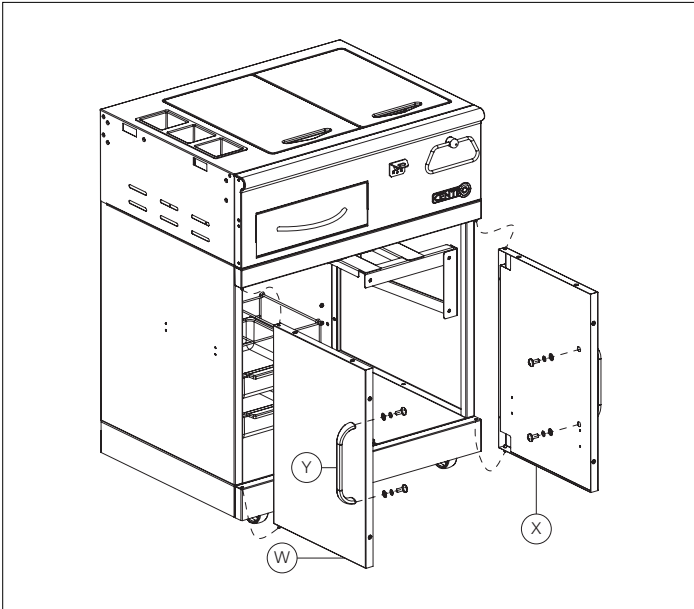

# 11

Assemble the upper bracket and lower bracket (D & O) of umbrella holder to the back side of the cart as shown using hardware #1, #2, and #3 (x4).

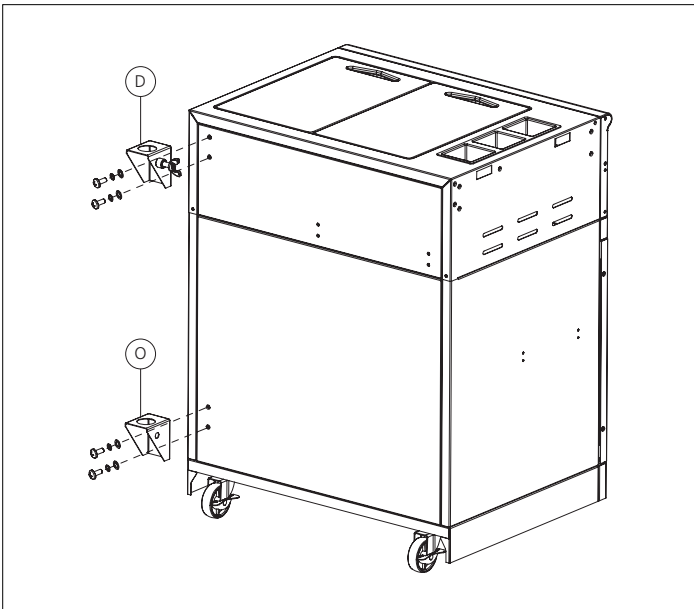

# 12

Remove the hardware from the towel bar (L). Assemble the towel bar set together with the towel bar first using the hardware just removed. Then assemble the towel bar assembly to the left of the cart as shown using hardware #1, #2, and #3 (x4).

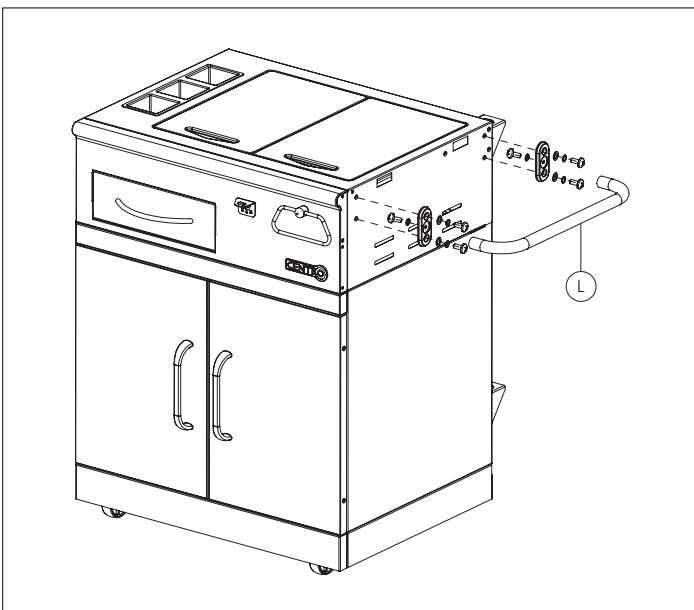

---

**DISTRIBUTOR**

Trileaf Distribution Trifeuil  
Toronto, Canada  
M4S 2B8

CENTRO 