

This Owner's Manual is provided and hosted by [Appliance Factory Parts](#).



# BROAN QTR100 Owner's Manual

[Shop genuine replacement parts for BROAN QTR100](#)



[Find Your BROAN HVAC Parts - Select From 1309 Models](#)

----- Manual continues below -----

# MODEL QTR100 VENTILATION FAN

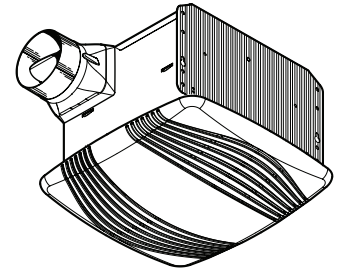

**Ultra-quiet, high performance bath fan with a modern-styled grille.**

### FEATURES

#### BLOWER:

- Plug-in, permanently lubricated motor - engineered for continuous operation
- Dynamically balanced centrifugal blower wheel for quiet, efficient performance
- Low RPM for quiet operation
- Resilient anti-vibration motor mounts

#### HOUSING:

- Rugged, 26 gauge, galvanized steel construction
- Polymeric, 4" round duct connector with tapered sleeve and no metallic clatter
- 7-5/8" height allows for 2" x 8" (nominal) joist installations
- Sturdy, easy, four-point mounting directly to joist
- Includes unique spacer (patent pending) for mounting to engineered "I" joists

#### GRILLE:

- Polymeric construction
- Innovative design - the result of extensive research with designers and consumers

#### CONTROLS (Purchase separately):

- Model 69VL (Ivory) / 69WL (White) - One rocker switch with "on" indicator light
- Other controls available from Broan-NuTone

U.L. Listed for use over bathtubs and showers when connected to a GFCI protected branch circuit (ceiling mount only).

3-Year Warranty

### TYPICAL SPECIFICATION

Ceiling Ventilator shall be Broan Model QTR100.

Ceiling Ventilator shall have corrosion resistant galvanized steel housing with four-point mounting capability. It shall be ducted to a roof or wall cap using 4" round ductwork.

Blower assembly shall be removable, have a centrifugal-type blower wheel and a permanently lubricated motor designed for continuous operation and mounted with resilient anti-vibration mounts.

Non-metallic damper/duct connector shall be included.

Air delivery shall be no less than 100 CFM and sound level no greater than 1.5 Sones. All air and sound ratings shall be certified by HVI.

Ceiling Ventilator shall be U.L. Listed for use over bathtubs and showers when connected to a GFCI protected branch circuit.



Broan-NuTone LLC, 926 West State Street, Hartford, WI 53027 (1-800-637-1453)

REFERENCE	QTY.	REMARKS	Project
			Location
			Architect
			Engineer
			Contractor
			Submitted by <span style="float: right;">Date</span>

# PERFORMANCE RATINGS

## MODEL QTR100 VENTILATION FAN

### HVI PERFORMANCE

Model	Sones @0.1" Ps	CFM @0.1" Ps
QTR100	1.5	100



HVI-2100 CERTIFIED RATINGS comply with new testing technologies and procedures prescribed by the Home Ventilating Institute, for off-the-shelf products, as they are available to consumers. Product performance is rated at 0.1 in. static pressure, based on tests conducted in AMCA's state-of-the-art test laboratory. Sones are a measure of humanly-perceived loudness, based on laboratory measurements.

### AIR FLOW PERFORMANCE

#### MODEL QTR100

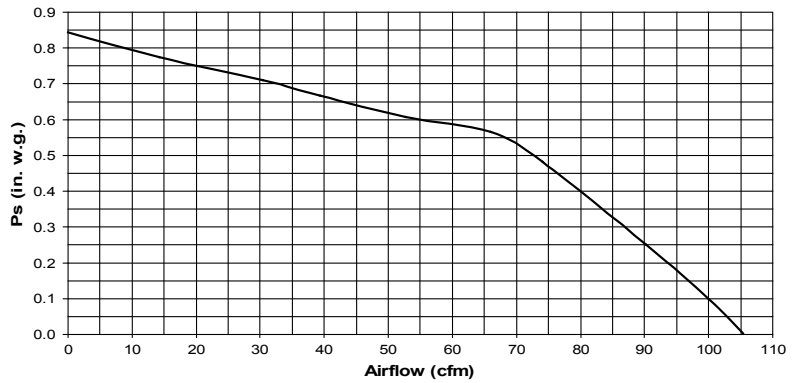

### AMPS

Model	Amps
QTR100	0.9

### WEIGHT

Model	Shipping Weight
QTR100	12.4 lbs.

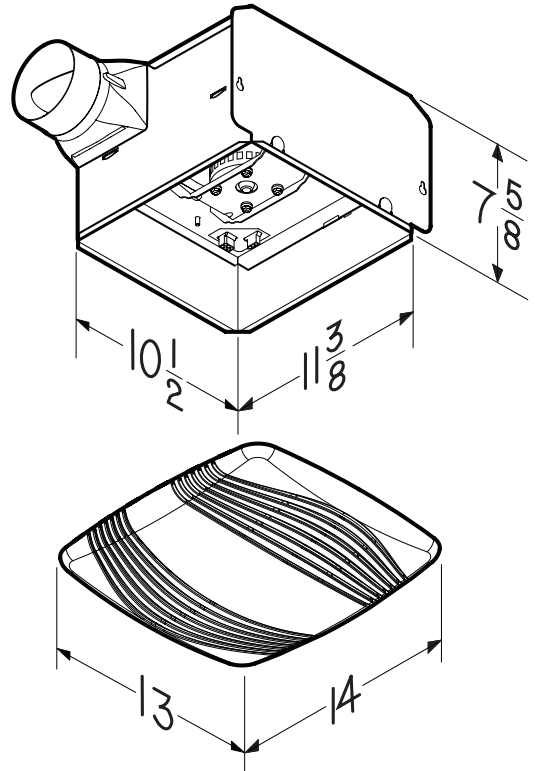

Broan-NuTone LLC, 926 West State Street, Hartford, Wisconsin 53027 (1-800-637-1453)