

This Owner's Manual is provided and hosted by [Appliance Factory Parts](http://www.appliancefactoryparts.com).



SUNBEAM 3822-100 Owner's Manual

**[Shop genuine replacement parts for SUNBEAM
3822-100](#)**



[Find Your SUNBEAM Small Appliance Parts - Select From 72 Models](#)

----- Manual continues below -----

Sunbeam[®]

2-SLICE TOASTER
Models 3822 & 3910

User Manual



IMPORTANT SAFEGUARDS

When using electrical appliances, basic safety precautions should be followed:

- READ ALL INSTRUCTIONS CAREFULLY.
- **Do not** touch hot surfaces. Metal parts can become hot. Use handles or knobs. All chrome surfaces become extremely hot.
- To protect against electrical shock, **do not** immerse cord, plug or toaster in water or other liquids.
- This appliance should not be used by young children or incapacitated persons. Supervise older children closely.
- **Do not** attempt to dislodge food when toaster is plugged in.
- **Do not** insert fingers or metallic utensils into slots when toaster is plugged in.
- **Do not** operate toaster near flammable materials such as curtains, wall fabric, etc., to prevent fire.
- Unplug from outlet when not in use and before cleaning. Allow to cool before putting on or taking off parts.
- **Do not** insert utensils or foil-covered or oversized foods in toaster as they may involve a risk of fire or electric shock.
- **Do not** pull, twist or otherwise abuse cord.
- Clean out accumulated crumbs frequently to avoid risk of fire or toaster malfunction. Unplug when not in use and before cleaning.
- **Special note: Do not** use foods that will drip coatings or fillings when heated. Such accumulations inside the toaster create unsanitary conditions and the possibility of fire or toaster malfunction.
- **Do not** operate any electrical appliance with a damaged cord or plug or after the appliance malfunctions or has been dropped or damaged in any manner. Return appliance to nearest Sunbeam Appliance Authorized Service Center for examination, repair or electrical or mechanical adjustment.

- Take care to **never** let a power cord hang over the edge of a table or countertop (Where it can be accidentally pulled) or touch any hot surface.
- **Do not** use outdoors or for commercial purposes.
- **Never** operate any appliance on top of a non-heat-resistant or flammable surface.
- **Never** leave appliance unattended when in use.
- **Do not** place appliance on or near a hot gas stove flame or electrical element, in a heated oven or microwave oven.
- Use this appliance only for its intended use as described in this manual. **Do not** use attachments that are not recommended by manufacturer; they may cause injury.

SPECIAL INSTRUCTIONS

THIS UNIT IS FOR HOUSEHOLD USE ONLY.

A short power supply cord is provided to reduce the risk of becoming entangled in or tripping over a long cord. Extensions cords may be used if care is exercised in their use. If an extension cord is used, the marked electrical rating of the extension cord should be at least as great as the electrical rating of the appliance. The cord should be arranged so that it will not drape over the countertop or tabletop where it can be pulled on by children or tripped over unintentionally.

POLARIZED PLUG INFORMATION.

To reduce the risk of electrical shock, this appliance has a polarized plug (one blade is wider than the other). As a safety feature, this plug will fit in a polarized outlet only one way. If the plug does not fit fully into the outlet, reverse the plug. If it still does not fit, contact a qualified electrician. **Do not** attempt to defeat this safety feature.

SAVE THESE INSTRUCTIONS

contents

Table of Contents

Welcome	1
Learning About Your Toaster	2
Using Your Toaster	3
Useful Hints	4
Care And Cleaning	5
One-Year Limited Warranty	6
How to Obtain Warranty Service	6

welcome

Welcome

Congratulations! You are the owner of a SUNBEAM® Toaster. Before you use this product for the first time, please take a few moments to read these instructions and keep it for reference. Pay particular attention to the Safety Instructions provided. Please review the product service and warranty statements. For your future reference, please note:

Date product received: _____

Service number: _____
(Located on the bottom of the toaster)

Learning About Your Toaster

This toaster is equipped with many safety and convenience features to give you optimum performance.

- A. Extra wide slots allow toasting of homemade bread, bagels, English muffins and pastries.
- B. Dual self-adjusting bread guides automatically adjust to bread thickness.
- C. Bread carriage lever is pressed to begin toasting.
- D. Toast lift – Press up on bread carriage lever to lift toast out of the bread slots.
- E. Light/dark selector knob lets you select the toast darkness.
- F. Stop button is pressed to stop the toasting process.
- G. Cool-Touch exterior.
- H. Pull-out, non-stick crumb tray. (Back of unit)

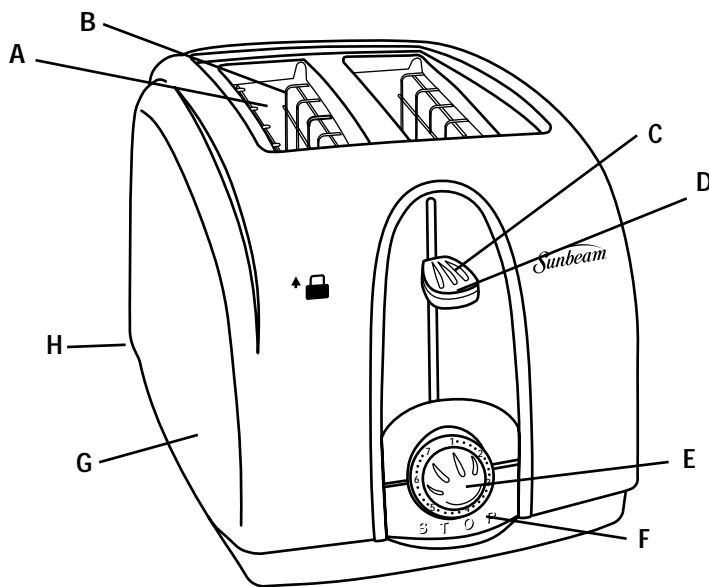

your toaster

Your Toaster

Using your Toaster

- Before use remove any stickers and wipe the body of your toaster with a damp cloth.
- Ensure that before plugging the toaster into the outlet, the bread carriage lever is in the resting position.
- Plug the cord in 120/127 volt, 60 HZ AC outlet. Position toaster at least 3 inches away from wall or rear of counter.
- Let the first toasting process take place without inserting any bread to preheat the new elements and burn off any dust, which may have accumulated during storage.
- Select the desired level of darkness by turning the “1-7” light/dark knob on the front panel of the toaster to the right for darker toast and to the left for lighter toast. Your selection should vary based on the moisture content, thickness of bread, whether fresh or frozen and your darkness preference.
- Next, place bread in slot and depress bread carriage lever downwards until it locks. Carriage lever will not stay down if toaster is not plugged in. The self-adjusting bread guides will automatically center the bread for even browning.
- After the desired level of darkness has been reached, the bread will pop up automatically and is ready for removal from the slots. The bread carriage will return to its original position and disconnect the elements, ready for the next toasting.

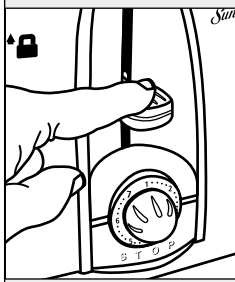
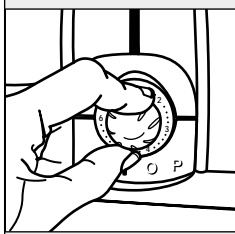

toasting

- To remove toast, press up on the bread carriage lever to lift toast out of the bread slots.
- To remove jammed toast, unplug toaster and remove bread once toaster has cooled down. **Never** insert fingers or metallic utensils into slots.

Do not wrap the cord around the main body of appliance during or after use.

Useful Hints

- If you wish to cancel the toasting process, press the stop button. The toaster will stop immediately and the food will pop up automatically.
- Most types of breads and pastries can be toasted; such as bagels, tea cakes, thick sliced breads, English muffins, waffles etc. Slices should not, however, be so thick as to cause burning or jamming in the bread slots.

Adjusting the Power Cord Length

Your toaster's cord storage area allows you to adjust the length of the power cord so that it is the exact length you desire.

- To adjust the length of the power cord:
Wrap the power cord around the cord storage posts on the base of the toaster until the cord is the length you desire.

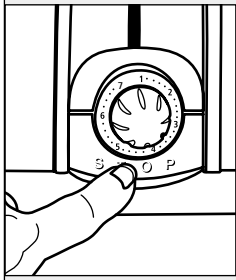
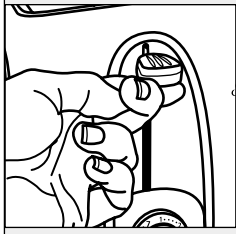

Care and Cleaning

- After use and before cleaning, unplug wall plug and wait for toaster to cool.
- Wipe the outside of toaster with a damp cloth and dry with another cloth or paper towel. **Do not** use abrasive cleaners.
- To avoid damage to toaster heating elements, **do not** use any pointed or sharp articles for cleaning the inside of the toaster.
- **Attention:** Empty the crumb tray frequently. Crumbs will accumulate in the crumb tray and could catch fire if not emptied periodically. When the toaster has cooled down completely, tap the sides of the toaster lightly to dislodge any crumbs caught in the toaster chamber and remove the crumb tray and empty it. Wipe the tray clean with a damp cloth or place it in the top rack of your dishwasher for cleaning. Tap sides again to ensure proper disposal. Return crumb tray back into the toaster before using again.

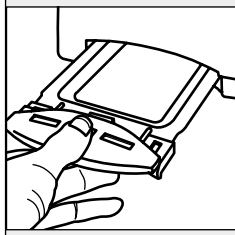

One-Year Limited Warranty

Sunbeam Products, Inc. ("Sunbeam") warrants that for a period of one year from the date of purchase, this product will be free from defects in material and workmanship. Sunbeam, at its option, will repair or replace this product or any component of the product found to be defective during this warranty period. Replacement will be made with a new or remanufactured product or component. If the product is no longer available, replacement may be made with a similar product of equal or greater value. This is your exclusive warranty.

The warranty is valid for the original retail purchaser from the date of initial retail purchase and is not transferable. Keep the original sales receipt. Proof of purchase is required to obtain warranty performance. Sunbeam dealers, service centers or retail stores selling Sunbeam products do not have the right to alter, modify or any way change the terms and conditions of this warranty.

This warranty does not cover normal wear of parts or damage resulting from any of the following: negligent use or misuse of the product, use on improper voltage or current, use contrary to the operating instructions, disassembly, repair or alteration by anyone other than Sunbeam or an Authorized Sunbeam Service Center. Further, the warranty does not cover Acts of God or nature, such as fire, flood, hurricanes, and tornadoes.

Sunbeam shall not be liable for any incidental or consequential damages caused by the breach of any express or implied warranty. Except to the extent prohibited by applicable law, any implied warranty of merchantability or fitness for a particular purpose is limited in duration to the duration of the above warranty. Some states, provinces or jurisdictions do not allow the exclusion or limitation of incidental or consequential damages or limitations on how long an implied warranty lasts, so the above exclusion or limitations may not apply to you. This warranty gives you specific legal rights and you may have the rights that vary by state, province and/or jurisdiction.

How to Obtain Warranty Service

Please, do not return this product to the place of purchase. Take the product to an authorized Sunbeam service center. You can find the nearest Authorized Sunbeam Service Center by calling 1 800 458-8407, or by visiting our website at www.sunbeam.com. If an Authorized Sunbeam Service Center is not conveniently located, attach a tag to the product that includes your name, address, daytime telephone number, and description of the problem. Include a copy of the original sales receipt. Carefully package the tagged product with the sales receipt and send either by UPS or Parcel Post with shipping and insurance prepaid to the Authorized Sunbeam Service Center address.

DO NOT RETURN THIS PRODUCT TO THE PLACE OF PURCHASE