

This Owner's Manual is provided and hosted by [Appliance Factory Parts](#).



FISHER & PAYKEL BFG-30BGD Owner's Manual

[Shop genuine replacement parts for FISHER & PAYKEL
BFG-30BGD](#)



[Find Your FISHER & PAYKEL Grill Parts - Select From 8 Models](#)

----- Manual continues below -----

outdoor Liberty Collection



Dual Side Burner/Griddle Unit



BFG-30BGD 30" Dual Side Burner/Griddle with optional cart, side shelves, wood inserts and back bar

With the Dual Side Burner/Griddle unit of the Liberty Collection you have the ability to prepare delicious dishes that are not customarily cooked outside. Add pancakes and bacon to your outdoor breakfast menu with ease using the large griddle surface. This unit even allows you to effortlessly host an omelet bar in your outdoor kitchen.

ADDITIONAL FEATURES:

- 2 x 17,000 BTU side burners
- Platform style grates allow easy movement from one burner to the other
- 12,000 BTU griddle plate
- Large 15-3/4" x 11" griddle plate
- Flat stainless steel covers included

Dual Side Burner/Griddle Dimensions (with optional grill cart)

Dual Side Burner/Griddle Model: BFG-30BGD
Cart Model: CAD-30 (shown with optional side shelves)

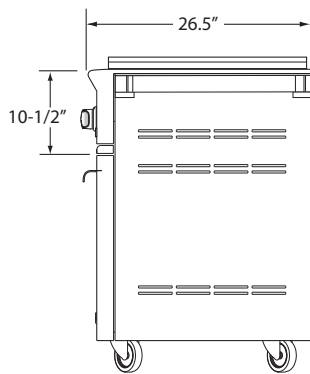
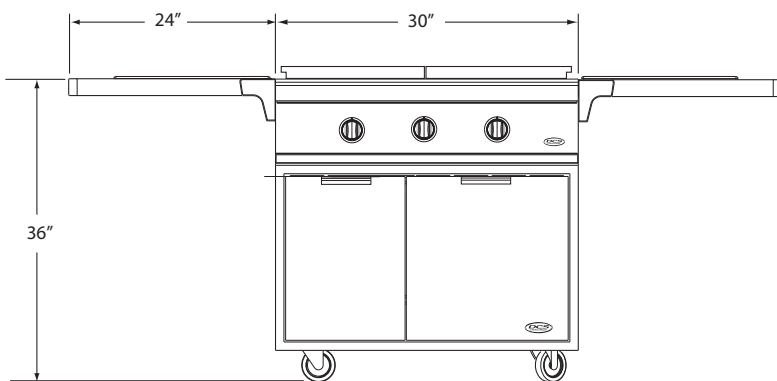

MODEL NUMBER	BFG-30BGD
GRIDDLE	12,000 BTU/HR
SIDE BURNERS	2 @ 17,000 BTU/HR
SHIPPING WEIGHT (SIDE BURNER/GRIDDLE HEAD)	120 LBS.
SHIPPING WEIGHT (OPTIONAL CART)	120 LBS.
SHIPPING DIMENSIONS (SIDE BURNER/GRIDDLE HEAD) (HEIGHT X WIDTH X DEPTH)	32" X 32" X 16"

Dual Side Burner/Griddle Island Preparation

Dual Side Burner/Griddle Model: BFG-30BGD

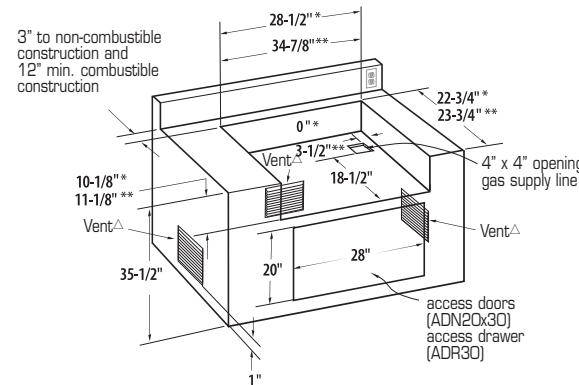

- * Standard cut-out dimensions for non-combustible enclosure
- ** Insulated jacket cut-out dimensions for combustible enclosure
- △ Island installation to use minimum of 3 vents providing 10 square inches per vent (typical)

Ordering Data:

Please specify gas type (natural or propane) when ordering

Gas Requirements:

Natural

- 1/2" NPT male with a 3/8" flare adapter
- Operational Pressure: 4" W.C.
- Supply Pressure: 6" to 9" W.C.

Propane

- 1/2" NPT male with a 3/8" flare adapter
- LP hose with a quick disconnect & fitting are shipped connected
- Operational Pressure: 11" W.C.
- Supply Pressure: 11" to 14" W.C.

Power Requirements:

- 9V battery

Island Ventilation Requirements:

It is recommended that adequate ventilation holes must be provided in the base of an enclosure in the event of a gas leak.

Side burner/Griddle Placement:

DO NOT build side burner/griddle under overhead unprotected combustible construction. Use only in well-ventilated areas. These units are for outdoor use only. If located in a consistent windy area (oceanfront, mountaintop, etc.) a wind break will be required.

Conversion Kits:

NG to LP and LP to NG conversion kits are available from your dealer.

Accessories

- Stainless Steel Grill Cart (CAD-30)
- Single or double side burners for built-in application
- Stainless Steel Access Doors for built-in application
- Stainless Steel Access Drawers for built-in application
- Insulated Jacket for built-in application
- Brazilian Cherry Chopping Board that fits in cart optional side-shelf
- Vinyl Grill Cover
- Wok and Wok Ring for use on side burners

We encourage you to find out more about these features and learn how they can make your cooking experience more enjoyable by visiting our learning page at: www.dcsappliances.com.

Because of continuing product improvement these specifications are subject to change without notice.