

This Owner's Manual is provided and hosted by [Appliance Factory Parts](#).



FISHER & PAYKEL CP-364GL Owner's Manual

[Shop genuine replacement parts for FISHER & PAYKEL
CP-364GL](#)



[Find Your FISHER & PAYKEL HVAC Parts - Select From 16 Models](#)

----- Manual continues below -----



CP SERIES PROFESSIONAL GAS COOKTOP

Installation Guide



MODELS:

CP-366
CP-364GL
CP-364GD
CP-484GG

CP-485GD
CP-486GL
CP-486GD



A MESSAGE TO OUR CUSTOMERS

Thank you for selecting this DCS professional Cooktop. Because of this appliance's unique features we have developed this Installation Guide. It contains valuable information on how to properly install your new appliance for years of safe and enjoyable cooking.

For your convenience, product questions can be answered by a DCS Customer Care Representative by phone: 1-888-936-7872, ou email: customer.care@fisherpaykel.com.

NOTE: Please write the Model, Code, and Serial Number on this page for references (located on the rating plate behind the unit right side)

MODEL NUMBER _____ SERIAL NUMBER _____

NOTE: Inspect the product to verify that there is no shipping damage. If any damage is detected, call the shipper and initiate a damage claim. DCS by Fisher & Paykel is not responsible for shipping damage.

DO NOT discard any packing material (box, pallet, straps) until the unit has been inspected.

WARNING

Improper installation, adjustment alteration, service or maintenance can cause property damage, injury or death. Read the installation, operating and maintenance instructions thoroughly before use, installing or servicing this equipment.

WARNING

If the information in this manual is not followed exactly, a fire or explosion may result causing property damage, personal injury or death.

Do not store or use gasoline or other flammable vapors and liquids in the vicinity of this or any other appliance.

DANGER

If You Smell Gas:

1. Do not try to light any appliance.
2. Do not touch any electrical switch; do not use any phone in your building.
3. Immediately call your gas supplier from a neighbor's phone. Follow the gas supplier's instructions.
4. If you cannot reach your gas supplier, call the fire department.
5. Installation and service must be performed by a qualified installer, service agency or the gas supplier.

WARNING

To reduce the risk of injury to persons in the event of a cooktop grease fire, observe the following: Turn burner off first. Smother flames with a close-fitting lid, cookie sheet, metal tray, baking soda or use a dry chemical or foam-type fire extinguisher. Be careful to prevent burns. If the flames do not go out immediately evacuate and call the fire department. Never pick up a flaming pan - You may be burned. **DO NOT USE WATER ON GREASE FIRES**, including wet dishcloths or towels - a violent steam explosion will result. Use an extinguisher **ONLY** if:

1. You know you have a Class ABC extinguisher, and you already know how to operate it.
2. The fire is small and contained in the area where it started.
3. The fire department is being called.
4. You can fight the fire with your back to an exit.

PLEASE RETAIN THIS MANUAL FOR FUTURE REFERENCE.

TABLE OF CONTENTS

INTRODUCTION	3
SAFETY PRACTICES AND PRECAUTIONS	4-6
MODELS	7
PLANNING THE INSTALLATION	8-9
UNPACKING AND HANDLING	9-10
VENTILATION REQUIREMENTS	11
CABINET PREPARATION	12-14
BACKGUARD INSTALLATION	15
ELECTRICAL CONNECTIONS	15
GAS HOOK-UP	16
TEST AND ADJUSTMENTS	17
CLEANING EXTERIOR SURFACES	18
INSTALLER FINAL CHECKLIST	19
HOW TO OBTAIN SERVICE	20
WARRANTY	21-22

INTRODUCTION

The DCS Professional CP Cooktops feature a large number of features varying with each model. All models feature a minimum of 4 surface burners, with the option of up to 6 surface burners on all models. All of the 48" and 36" Cooktops feature the possibility of various grill and griddle combinations. All cooktop models require the installation of one of the two offered backguards, if installed with less than 12" of clearance to combustible material. See page 14.

IMPORTANT INSTALLATION INFORMATION

The cooktops are tested in accordance with ANSI Z21.1 Standard for Household Cooking Gas Appliances. These cooktops must be installed in conjunction with a suitable overhead vent hood. (See ventilation requirements). Due to the professional high heat capacity of this unit, particular attention should be paid to the hood and duct work installation to ensure it meets local building codes. To eliminate risk of burns or fire by reaching over heated surface units, cabinet storage located above the surface units should be avoided.

Check local building codes for the proper method of cooktop installation. Local codes vary. Installation, electrical connections, and grounding must comply with all applicable codes. In the absence of local codes, the cooktop should be installed accordance with the National Fuel Gas Code ANSI Z223.1 and National Electrical Code ANSI / NFPA 70. Be sure that the unit being installed is set up for the kind of gas being used. The gas cooktop is shipped from the factory set and adjusted for natural gas or LP (propane), depending on the specific model ordered. **Verify that the cooktop is compatible with gas supply at the installation site before proceeding further.** Return cooktop to dealer if unit is not set for site gas supply.

SAFETY PRACTICES AND PRECAUTIONS

When properly cared for, your new DCS Appliance has been designed to be a safe, reliable cooking appliance. When using this restaurant caliber appliance, use it with extreme care, as this type appliance provides intense heat and can increase the accident potential. Basic safety precautions must be followed when using kitchen appliances, including the following:

- Read the Use and Care Manual, which came with this appliance, thoroughly before using your new appliance. This will help to reduce the risk of fire, electric shock, or injury to persons.
- Begin by insuring proper installation and servicing. Follow the installation instructions in this manual. Be sure to have a qualified technician install and ground this appliance before using.
- Have the installer show you where the gas supply shut-off valve is located so you will know how and where to turn off the gas to the appliance.
- If you smell gas, the installer has not done a proper job of checking for leaks. You can have a small leak and therefore a faint gas smell if the connections are not completely tight. Finding a gas leak is not a “do-it-yourself” procedure. Some leaks can only be found with the burner control in the ON position and for your protection it must be done by a qualified service technician.
- If by some chance a burner goes out and gas escapes, open a window or a door to let the room air out. Do not attempt to use the appliance until the gas has had time to dissipate. Follow the instructions on page 1, “For your safety – if you smell gas”.
- This appliance has been factory assembled for natural or LP gas. It should be correctly adjusted from the factory for the type of gas that is used.
- Do not repair or replace any part of this appliance unless it is specifically recommended in this manual. All other servicing should be referred to a qualified technician.
- Children should not be left alone or unattended in an area where appliances are in use. They should never be allowed to turn knobs, push buttons, sit or stand on any part of an appliance while in operation.

WARNING:

Do not store items of interest to children above or at the back of any appliance. Children could be seriously injured if they should climb onto the appliance to reach these items.

- Never store anything on the cooktop. Flammable materials can catch fire, plastic items may melt or ignite and other types of items could be ruined.
- Do not hang articles from any part of the appliance or place anything against the oven. Some fabrics are quite flammable and may catch on fire.
- If the appliance is near a window be certain the curtains do not blow over or near the cooktop burners; they could catch on fire.
- Do not use water on grease fires. Turn all burners OFF, then smother fire with baking soda or use a dry chemical or foam-type fire extinguisher.
- Never let clothing, pot holders, or other flammable materials come in contact with, or too close to, any burner or burner grate until it has cooled. Fabric may ignite and result in personal injury.
- Be certain to use only dry pot holders: moist or damp pot holders on hot surfaces may cause burns from steam. Do not use a towel or other bulky cloth in place of pot holders. Do not let pot holders touch hot burners, or burner grates.
- For personal safety, wear proper apparel. Loose fitting garments or hanging sleeves should never be worn while using this appliance. Some synthetic fabrics are highly flammable and should not be worn while cooking.

SAFETY PRACTICES AND PRECAUTIONS

- Do not use aluminum foil to line any part of the cooktop. Doing so, heat will be trapped underneath it. This trapped heat can upset the cooking performance and can damage the finish of the cooktop parts.
- This appliance is for cooking. Never use the cooktop to warm or heat a room. This could damage the cooktop.



WARNING! NEVER use this appliance as a space heater to heat or warm the room. Doing so may result in carbon monoxide poisoning.

- When using the cooktop: Do not touch the burner grates or the immediate surrounding area. Areas adjacent to the burners may become hot enough to cause burns.
- Never leave the cooktop unattended when using high flame settings. When cooking with high flame settings, boil overs may cause smoking and greasy spill overs may ignite. More importantly, if the burner flames are smothered by a severe boil over which effects the igniter, unburned gas will escape into the room.
- Only certain types of glass, heat-proof glass-ceramic, ceramic, earthen ware, or other glazes utensils are suitable for cooktop use. This type of utensil may break with sudden temperature changes. Use only on low or medium flames settings according to the manufacturer's directions. The use of professional utensils is recommended.
- Do not heat unopened food containers; a build up of pressure may cause the container to burst.
- During cooking, set the burner control so that the flame heats only the bottom of the pan and does not extend beyond the bottom of the pan. This could heat and/or melt the handles, and may increase cooking time.
- Always use utensils that have flat bottoms large enough to cover the burner. The use of undersized utensils will expose a portion of the flame to direct contact and may result in ignition of clothing.
- To minimize burns, ignition of flammable materials and unintentional spill overs, position handles of utensils inward so they do not extend over adjacent work areas, cooking areas, or the edge of the cooktop.
- Hold the handle of the pan to prevent movement of the utensil when stirring or turning food.
- Grease is flammable. Let hot grease cool before attempting to handle it. Avoid letting grease deposits collect around the cooktop burners. Clean after each use or boil over.
- For proper lighting and performance of the cooktop burners, keep the burner ports clean. It may be necessary to clean these when there is a boil over or when the burner does not light, even though the electronic igniters click.
- Do not use the grill for cooking excessively fatty meats or products which promote flare-ups. Do not use cooking utensils on the grill.

SAFETY PRACTICES AND PRECAUTIONS

- Clean the cooktop with caution. Avoid steam burns; do not use a wet sponge or cloth to clean the cooktop while it is hot. Some cleaners produce noxious fumes if applied to a hot surface. Follow directions provided by the cleaner manufacturer.
- Be sure all the cooktop controls are turned off and the appliance is cool before using any type of aerosol cleaner on or around the appliance. The chemical that produces the spraying action could, in the presence of heat, ignite or cause metal parts to corrode.
- Clean the ventilator hood and filters above the cooktop frequently so grease from cooking vapors does not accumulate on them.
- Turn the ventilator OFF in case of fire or when intentionally “flaming” liquor or other spirits on the cooktop. The blower, if in operation, could unsafely spread the flames.
- DO NOT obstruct the flow of combustion or ventilation air to the appliance. Be sure a fresh air supply is available.
- For safety reasons and to avoid damage to the appliance never sit, stand, or lean on the cooking surface.
- Service should only be done by authorized technicians. Technicians must disconnect the power supply before servicing this appliance.

WARNING:

California Proposition 65 - The burning of gas cooking fuel generates some by-products which are known by the State of California to cause cancer or reproductive harm. California law requires businesses to warn customers of potential exposure to such substances. To minimize exposure to these substances, always operate this unit according to the instructions contained in this booklet and provide good ventilation to the room when cooking with gas.

RECOMMENDATIONS ON HOOK-UP TO GAS SUPPLY:

A manual valve must be installed external to the appliance, in an accessible location from the front for the purpose of shutting off the gas supply. The supply line must not protrude beyond the back of the unit. Make sure the gas supply is turned off at the wall valve before connecting the appliance.

The gas supply connections should be made by a qualified technician and in accordance with local codes or ordinances. In the absence of a local code, the installation must conform to the latest edition of National Fuel Gas Code ANSI Z223.1.

NOTE:

This product must be installed by a licensed plumber or gas fitter when installed within the Commonwealth of Massachusetts.

NOTE:

*(mandatory for the State of Massachusetts)
Alternate method of supplying gas must be installed into the unit.*

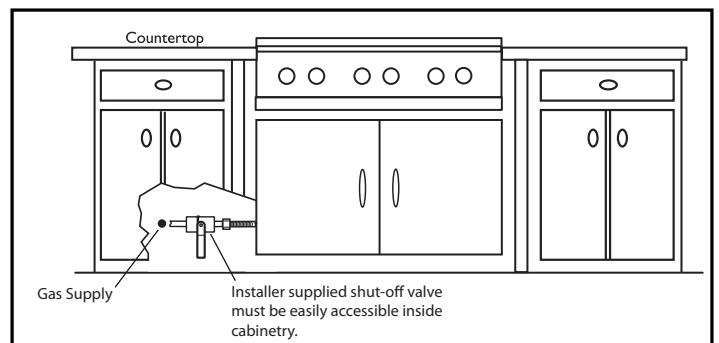

MODELS

48" CP COOKTOP MODELS

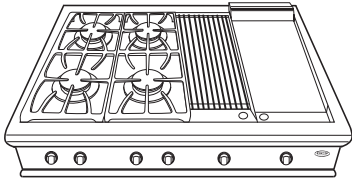

CP-484GG

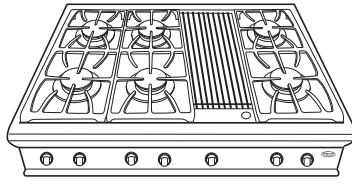

CP-486GL

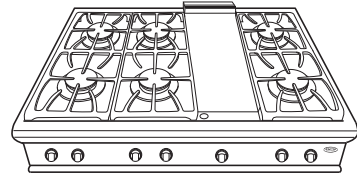

CP-486GD

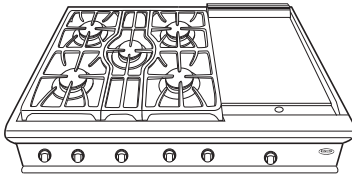

CP-485GD

36" CP COOKTOP MODELS

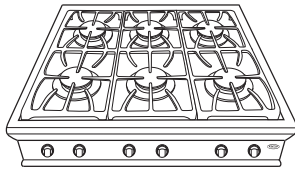

CP-366

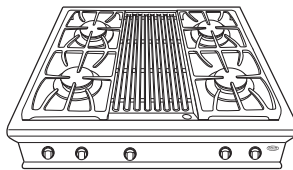

CP-364GL

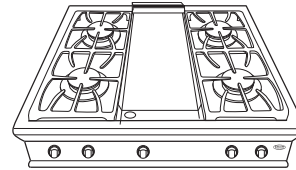

CP-364GD

PLANNING THE INSTALLATION

IMPORTANT INSTALLATION INFORMATION

All cooktop models with less than a 12" clearance between combustible material and the back edge of the cooktop, require the installation of one of the two offered Wall Mount Backguards – see page 15.

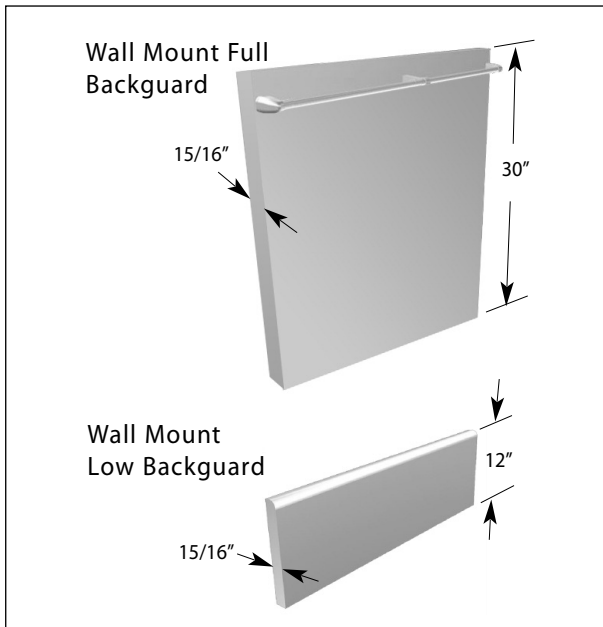

FIG. 1

	Model Number	
	Low Backguard	Full Backguard
48" Cooktop	BGC-1248	BGC-3048
36" Cooktop	BGC-1236	BGC-3036

PLANNING THE INSTALLATION

RECOMMENDED INSTALLATION INSTRUCTION

Install components in the following order:

- A. Vent Hood
- B. Backguard System (sold separately)
- C. Cooktop

1. Locate cooktop according to cooktop installation instructions.
2. Measure distance from counter surface to top of trim on cooktop adding 1/8" for backguard clearance.
3. Transfer this measurement to the wall. This will mark the bottom of your backguard.
4. From this line measure 30-1/16" up wall to mark top of 30" backguard. This is the minimum height that the bottom of your vent hood can be installed.
5. Follow vent hood manufacturer's installation instructions to install vent hood.
6. Follow backguard installation instructions to install backguard.
7. Connect gas and electric connections and slide cooktop into position.

NOTE:

A manual gas supply valve must be installed. See page 16.

UNPACKING AND HANDLING

CAUTION:

Proper equipment and adequate manpower must be used in moving the cooktop to avoid personal injury or damage to the unit.

MOVING AND PLACING THE COOKTOP

The cooktops have a shipping weight of approximately 228 pounds (36" models) and 324 pounds (48" models). After removal of packing materials, it is recommended that the grates and drip pan (below knobs) be removed to facilitate handling. This will reduce the weight to about 150 pounds.

- DO NOT REMOVE THE GRILL OR GRIDDLE ASSEMBLIES.

NOTE:

If a solid side cabinet wall exists on one or both sides, you will need to notch the front corner of the cabinet to match the counter top notch and to provide clearance for the cooktop front (see page 14).

It may be necessary to remove the cooktop knobs to pass through some doorways. With the knobs removed a 29-3/8" wide opening is required. Remove the outer carton and packing material from the shipping base. The cooktop is held to the skid by four straps. After removing the straps, the cooktop must be lifted and removed from the skid.

UNPACKING AND HANDLING

- The professional cooktop should be moved close to its final location. Electric and gas connections should be made (pgs. 15 & 16) and the backguard installed (as required, pg. 8 & 15) before the cooktop is placed in its final position. The grill and griddle sections are fastened in place at the front with screws. They are designed to be stationary and not meant to be removed for cleaning. The griddle has two leveling screws beneath the rear flue cover which can be used to adjust the griddle to the desired slope. The center screw is for shipping and should be removed. See Fig. 2.

ANCHORING THE COOKTOP

- Due to the weight of the cooktop, along with a built-in side frame gasket that is meant to rest and create a seal on the counter top once installed, it is not necessary to anchor the unit to the counter.

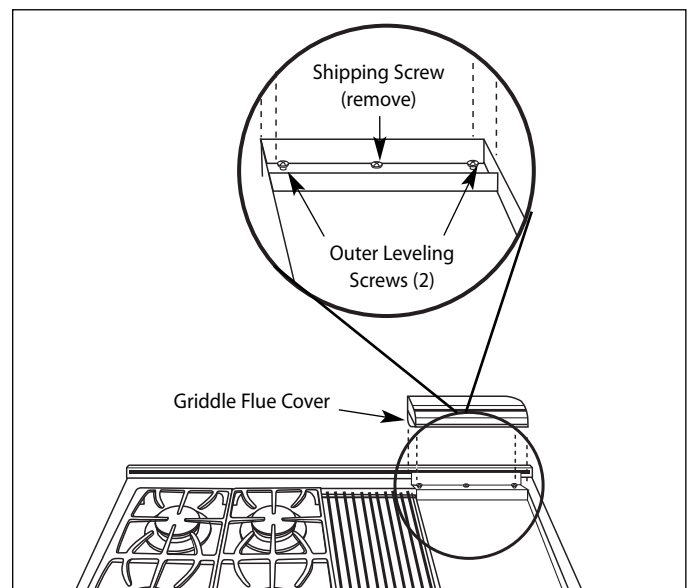

Fig. 2

VENTILATION REQUIREMENTS

A suitable exhaust hood must be installed above the range. The following chart indicates the minimum blower capacity recommended for hood ventilation.

Ventilation Unit	Standard Counter Installation Recommendations	Island Installation Recommendations
HOOD	24" Deep x Unit Width	30" Deep x 36" at Bottom
BLOWER	48" Cooktop 1200 CFM	1200 CFM
	*36" Cooktop 600-1200 CFM	600-1200 CFM

* When installing a unit featuring a grill, GL models, requires a 1200 CFM ventilation unit.

CAUTION:

Ventilation hoods and blowers are designed for use with single wall ducting. However, some local building codes or inspectors may require double wall ducting and/or damper. Consult local building codes and/or local agencies, before starting, to ensure that hood and duct installation will meet local requirements.

Hood blower speeds should be variable to reduce noise and loss of heated or air conditioned household air when maximum ventilation is not required. Normally, the maximum blower speed is only required when using the grill.

For best smoke elimination, the lower edge of the hood should be installed a minimum of 30" to a maximum of 36" above the cooktop cooking surface, (page 12). If the hood contains any combustible materials (i.e. a wood covering) it must be a minimum of 36" above the cooking surface.

Due to a high volume of ventilation air, a source of make-up air (outside replacement air) is recommended. This is particularly important for tightly sealed and insulated homes. A reputable heating and ventilating contractor should be consulted.

CABINET PREPARATION

1. To ensure professional results, the cabinet and countertop openings should be prepared by a qualified cabinet worker. We recommend having the cooktop available before cutting the opening for more precise dimension verification.
2. The clearances shown in Fig. 8 pg. 14 are required for all types of backguard installations.
3. The cooktop is designed to hang from the countertop from its rear and side flanges. The countertop, however, must be strong enough to support this heavy cooktop. It may be necessary to add a supporting cleat along each side or another form of support such as a 2" x 4" corner brace on each side, or a deck to set the cooktop on. See Fig. 3 & 5.
4. The cooktop can be installed in various positions with the front either flush or projecting, depending on the countertop depth. See Fig. 4 & Fig. 7 (cooktop side view).
5. Establish the centerline of the desired cooktop location. It should be the same as the center of the overhead ventilation hood.

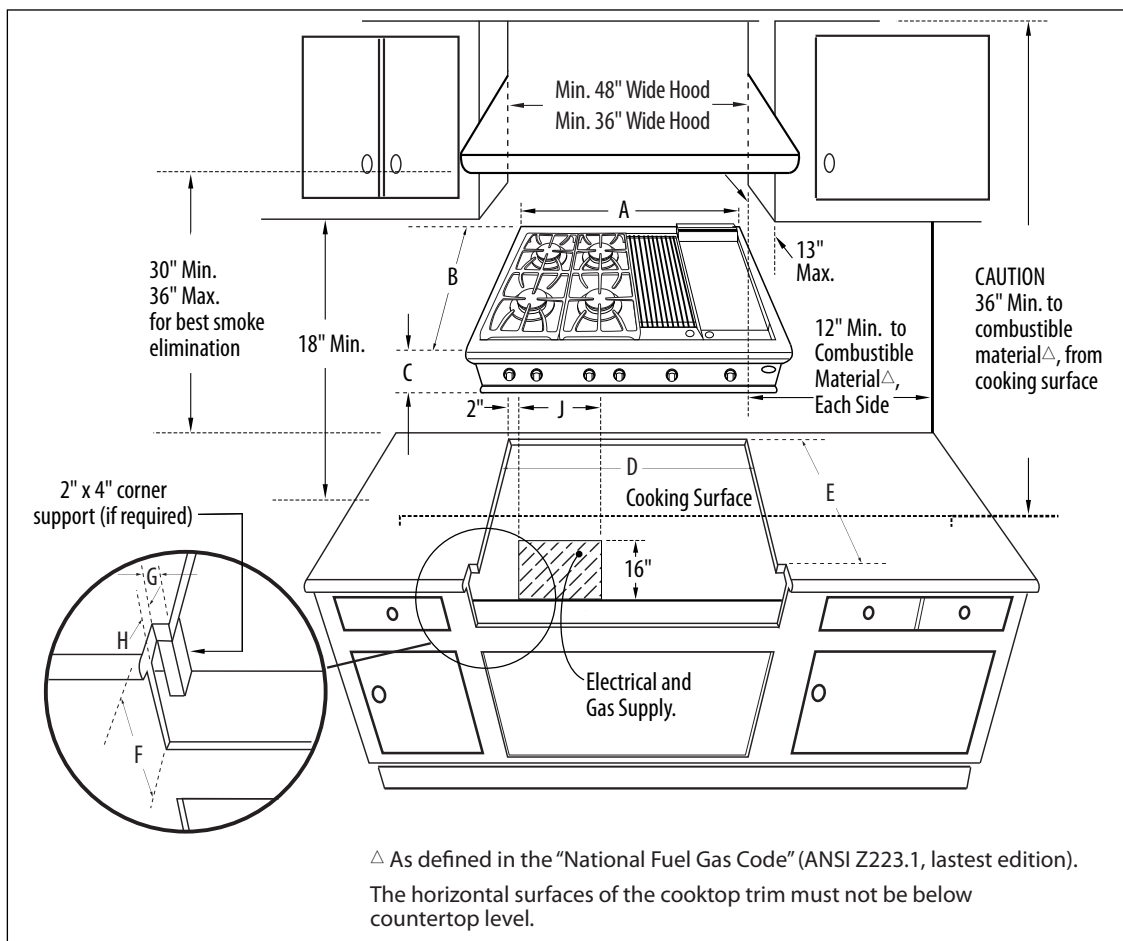

Fig. 3

Models	A	B	C	D	E	F	G	H	J
CP-48 Models	47-7/8"	26-1/2"	8-7/16"	46-15/16"	22-3/4"	8"	7/8"	0 ~ 2-1/2"	17"
CP-36 Models	35-7/8"	26-1/2"	8-7/16"	34-15/16"	22-3/4"	8"	1/2"	0 ~ 2-1/2"	7"

CABINET PREPARATION

6. Cut the openings for the following installation:
- Standard counter top installation, see Fig. 8A
 - Deep counter or island installation, see Fig. 8B

NOTE:

If the deck is used, the sides or bottom of the cutout may be solid combustible or non-combustible material. If the bottom is solid, provide a 6" x 6" cutout in the left rear corner for the gas inlet and power cord clearance. See Fig. 6.

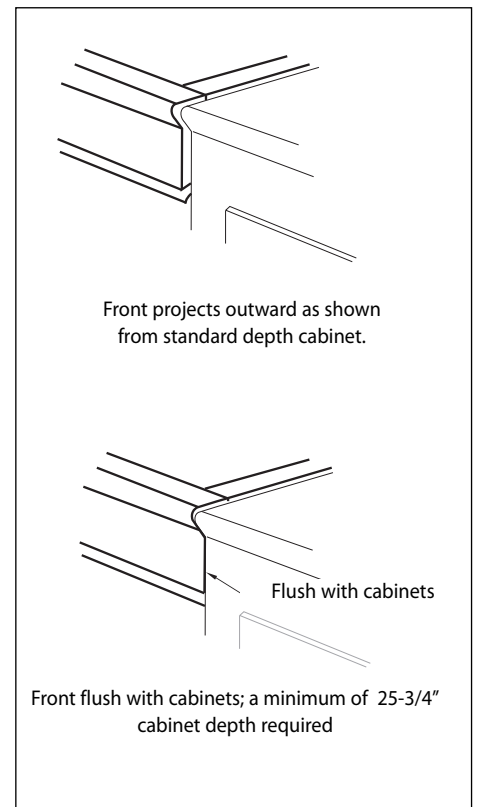

Fig. 4

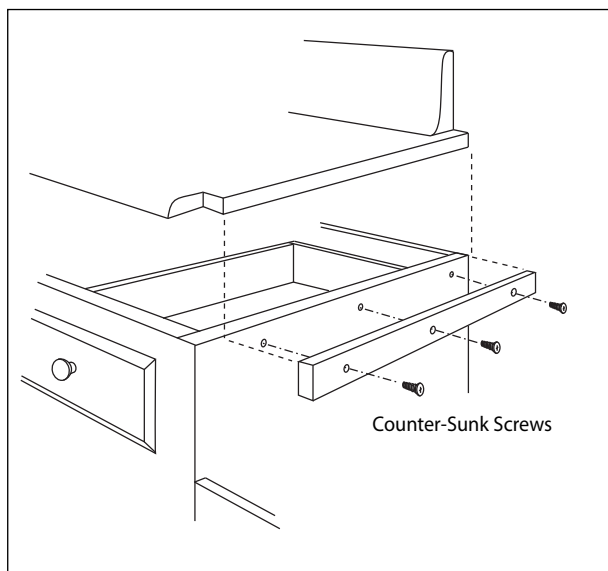

Fig. 5

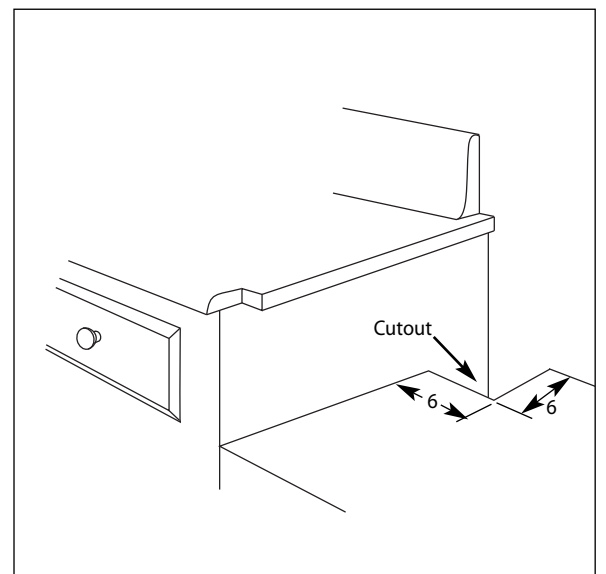

Fig. 6

CABINET PREPARATION

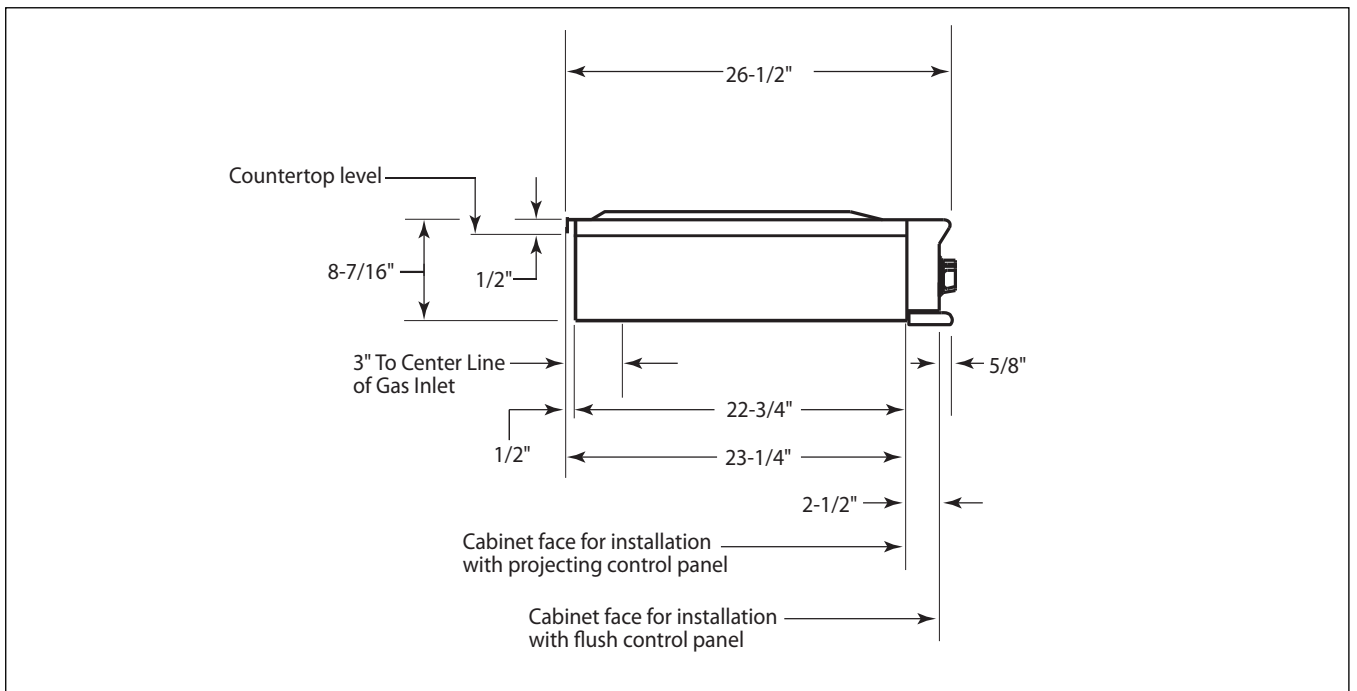

Fig. 7

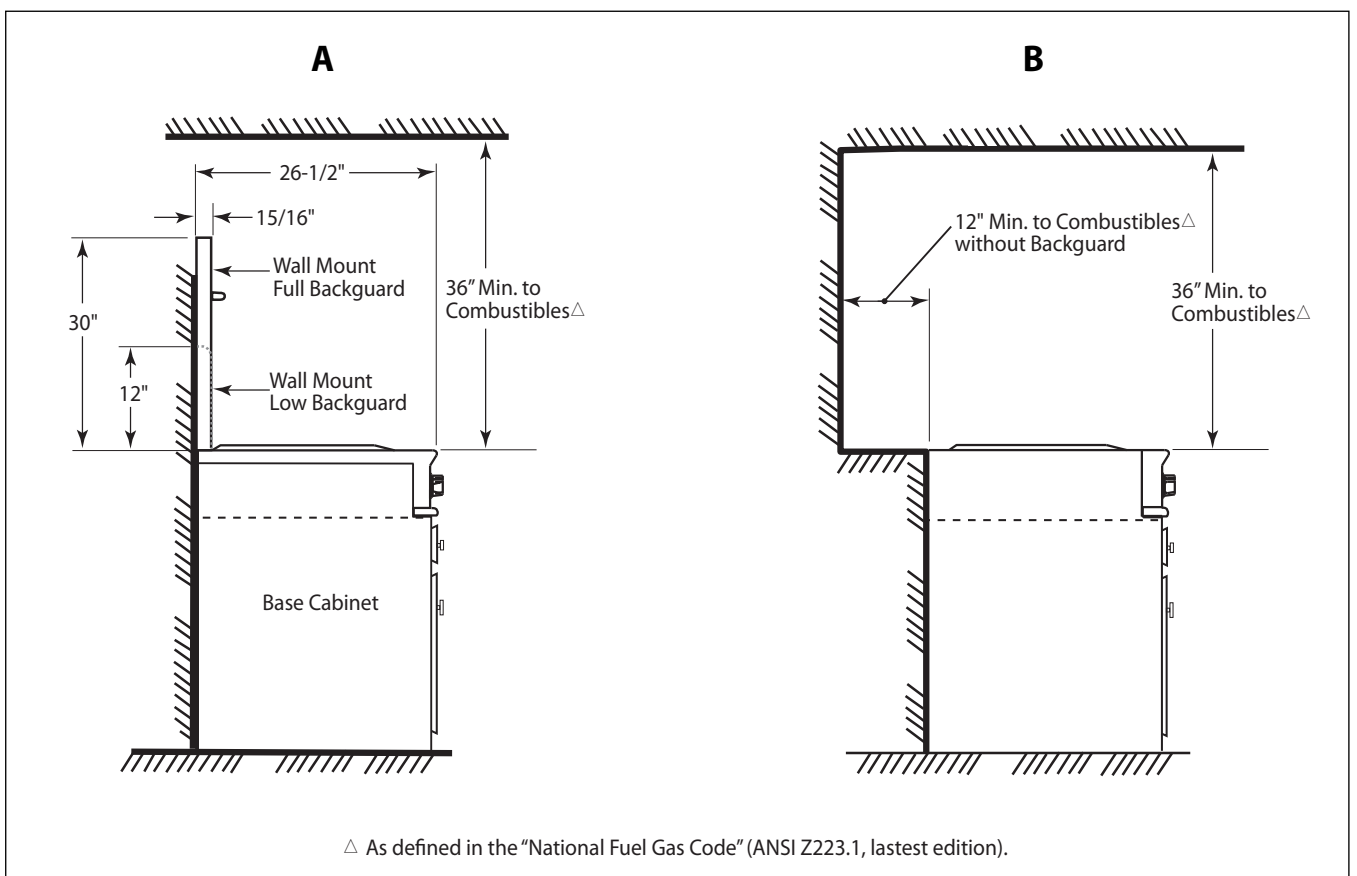

Fig. 8

BACKGUARD INSTALLATION

The backguard is located as shown in Fig. 9. Secure the backguard to the wall behind the range. Specific instructions for installation of the full backguard or low backguard can be found packaged with the backguard. See also page 8, "Planning The Installation" section. A backguard must be installed when there is less than a 12" clearance between combustibles and the back of the range (above the cooking surface). See fig. 8.

DCS backguards are sold separately.

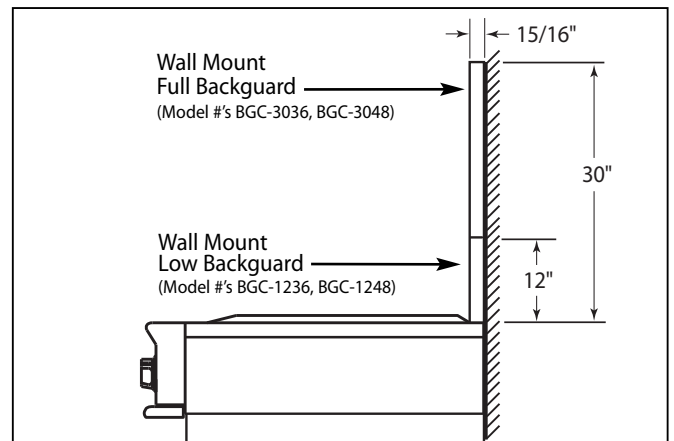

Fig. 9

ELECTRICAL CONNECTIONS

ELECTRICAL REQUIREMENTS

- 120 VAC, 60 Hz., single phase
- CP-48: 15 Amp. Max. (use 15 Amp. circuit)
- CP-36: 15 Amp. Max. (use 15 Amp. circuit)

Always disconnect electric supply cord from the wall outlet or service disconnect before servicing this appliance. Observe all governing codes and ordinances when grounding, in absence of which, observe National Electrical Code ANSI / NFPA No. 70.

RECOMMENDED GROUNDING METHOD

This appliance is factory equipped with a power supply cord with a three-prong grounding plug (with polarized parallel blades). It must be plugged into a mating grounding type receptacle, connected to a correctly polarized 120 Volt circuit. If the circuit does not have a grounding type receptacle, it is the responsibility and obligation of the installer to have the existing receptacle changed to a properly grounded and polarized receptacle in accordance with all applicable local codes and ordinances by a qualified electrician. In the absence of local codes and ordinances, the receptacle replacement shall be in accordance with the National Electrical Code.

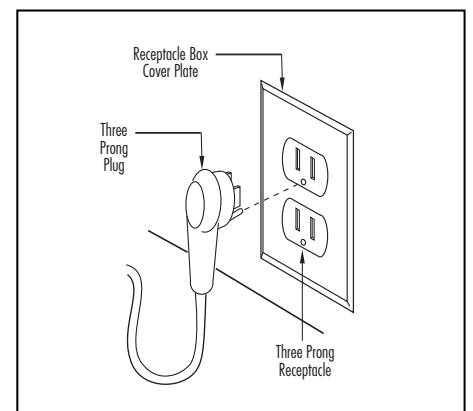

Fig. 10

Note:

The third prong should not, under ANY circumstances, be cut or removed.

GAS HOOK-UP

GAS REQUIREMENTS

Verify the type of gas supplied to the location. The cooktop is shipped from the factory set up and adjusted for Natural Gas or LP (propane), depending on the specific model ordered. **Verify that the cooktop is compatible with gas supply at the installation site before proceeding further.** Return the cooktop to the dealer if the unit is not set for the gas supplied at the site.

NATURAL GAS

■ Connection: 1/2" NPT Minimum 5/8" dia. flex line.

■ Supply Pressure: 6" to 14" W.C.

LP GAS

■ Connection: 1/2" NPT Minimum 5/8 dia. flex line.

■ Supply Pressure: 11" to 14" W.C.

A regulator is required at the LP source to provide a maximum of 14" W.C. to the cooktop regulator.

HOOK-UP TO GAS SUPPLY

A manual valve must be installed external to the appliance, in an accessible location from the front for the purpose of shutting off the gas supply (Fig. 11). Make sure the gas supply is turned off at the wall valve before connecting the appliance. The gas supply connections should be made by a qualified technician and in accordance with local codes or ordinances. In the absence of a local code, the installation must conform to the latest edition of National Fuel Gas Code ANSI Z223.1.

To prepare the unit for connection to the gas supply, thread the supplied 1/2" pipe nipple into the elbow on the end of the manifold. The elbow is located inside the chassis of the unit, on the end of the manifold, facing down. See fig.12. It is accessible through the square cutout in the left rear corner of the chassis bottom. Connect the outlet of the regulator to the exposed end of the nipple, connect the flex line from the gas supply to the inlet side of the regulator.

NOTE:

Pipe seals must be used on all pipe threads.

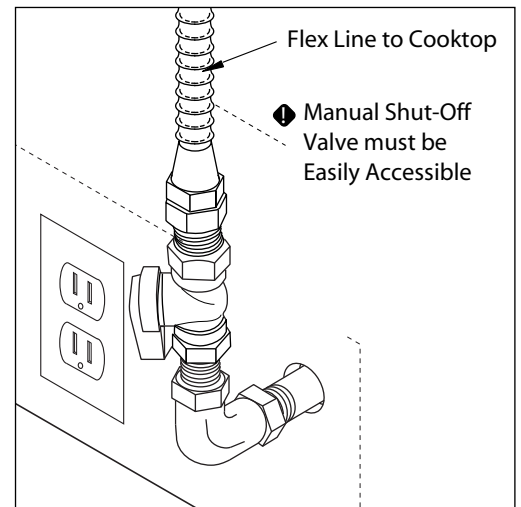

Fig. 11

CAUTION:

The appliance must be isolated from the building's gas supply piping system by closing its individual manual shut-off valve during any pressure testing of the gas supply piping system at test pressures equal to or less than 1/2 psig (3.5kPa.). The appliance and its individual shut-off valve must be disconnected from the gas supply piping system during any pressure testing of the system at the test pressures in excess of 1/2 psig (3.5kPa.). When checking the manifold gas pressure, the inlet pressure to the regulator should be at least 7.0" W.C. for natural gas or 12.0" for LP.

NOTE:

The arrow on the regulator indicating direction of gas flow should be pointing towards the unit. The flex line for the gas supply must be metal and be approved by an approved certifying agency (AGA, CGA, or UL). Never use a hose made of rubber or other synthetic material, as the heat may cause the hose to melt and develop leaks.

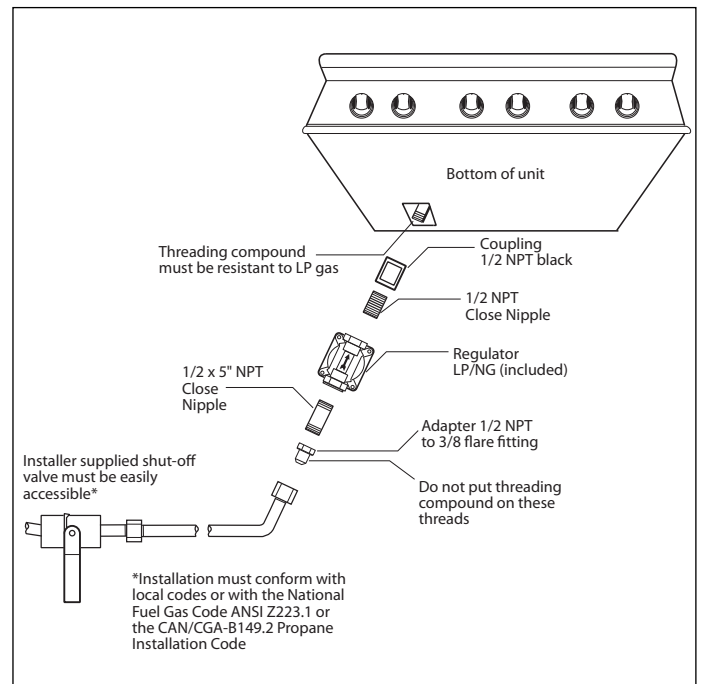

Fig. 12

TEST AND ADJUSTMENTS

WARNING:

For warranty coverage, DCS requires that burner adjustments be made by a qualified technician at the time of installation. Extreme care should be used when adjustments are made after installation.

COOKTOP BURNERS

The cooktop burners are not adjustable. Proper operation is achieved when the correct orifices for gas supply are installed at the factory, based on model ordered.

When installing the burner port ring, be sure that the two locating pins in the bottom side of the brass port ring are properly aligned with the locating notch and center holes on the top side of the simmer ring. Incorrect alignment will produce a potentially dangerous flame and poor burner performance.

Note:

No air shutter adjustment is possible on the cooktop burners. Burner flames should be blue and stable with no yellow-tipping (some yellow-tipping is normal with LP gas), excessive noise, or lifting of flame from the burner (Fig. 13).

COOKTOP BURNER LIGHTING NOTE

The cooktop burners have an infinite number of heat settings and there are no fixed positions on the control knobs between HI and LO. To turn the cooktop burner on, push in on the control knob and turn it counter-clockwise to the "LITE" position. An audible clicking sound will be heard. When the gas has been ignited by the electronic spark igniter, turn the knob to the desired setting (Fig. 14).

Note:

The igniter will continue to click until a flame is present. If the cooktop burner does not ignite, check the spark igniter by listening for a clicking sound. If you do not hear the igniter click, turn off the burner. Check for a tripped circuit breaker, blown fuse, or poor wire connection to the igniter.

WARNING:

When turning on any cooktop burner, be sure to stop at the "LITE" position before turning the burner to a flame setting for cooking. If the burner is not lit and it is turned beyond the "LITE" position, to HI, MEDIUM, or LO, there will be a burst of flame when the burner does light. This could cause burns or damage to the surrounding countertop.

THIS ADJUSTMENT SECTION APPLIES TO THE GRIDDLE AND GRILL BURNERS.

Check for the proper burner flame characteristics and adjust air shutters if necessary (fig. 15). Each valve and air shutter is individually tested and adjusted prior to shipment. Normally adjustment is not required, however, vibration during transit, gas conversion or variations in the local gas supply may make minor adjustments necessary. Burner flames should be blue and stable with no yellow tips, excessive noise or lifting of the flame from the burner. If any of these conditions exist, check that the air shutter or burner ports are not blocked. If this condition persists, adjust the air shutter as required. If the flame is too yellow, indicating insufficient air, adjust the shutter counter-clockwise to increase air inlet. If the flame is noisy or tends to lift away from the burner, indicating too much air, turn the shutter clockwise to reduce air. The griddle flames should be 1-1/2" to 2". The grill burner flames should be 3/8" to 5/8" (fig. 16).

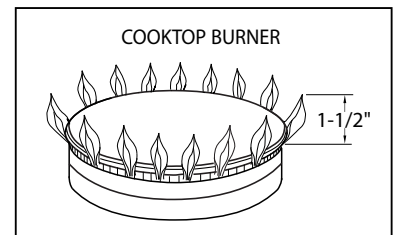

FIG. 13

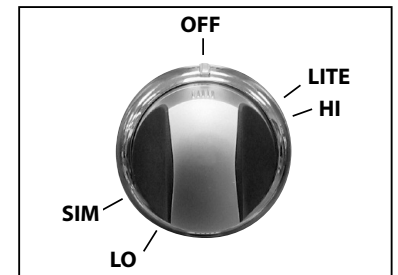

FIG. 14

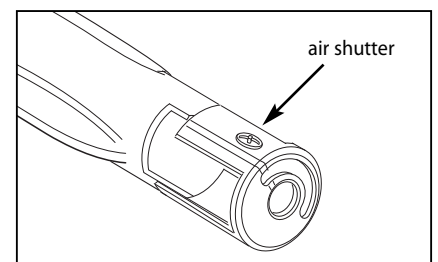

Fig. 15

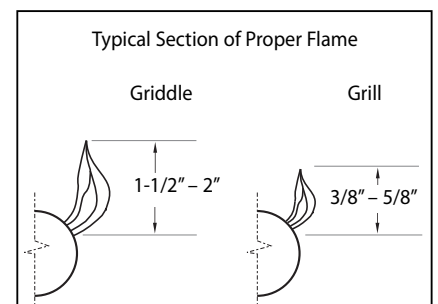

Fig. 16

CLEANING EXTERIOR SURFACES

The stainless steel surfaces may be cleaned by wiping with a damp soapy cloth or sponge. Any liquid soap (like Dawn or Stainless Steel Magic) will remove fingerprints and smears. Do not use steel wool as it will scratch this surface.

INSTALLER FINAL CHECKLIST

GENERAL

- Placement of unit.
- Specified clearance maintained to cabinet surfaces.
- Unit Level - front to back, side to side.
- All packaging material and tie straps removed, drip pans clean and empty.
- Backguard attached if there is less than 12" clearance above the cooking surface to combustibles behind unit.
- Radiant tray placed in grill unit (if equipped). The two grill racks in place.

ELECTRICAL

- Receptacle with 15 ampere over-current protection is provided for service cord connection.
- Adequate ground connection.

GAS SUPPLY

- Connection: 1/2 NPT with a minimum 5/8" diameter flex line. Site gas supply is compatible with range model, and sufficient pressure is available (see gas requirements pg. 16).
- The pressure regulator which is connected to the manifold is set for 5.0" W.C. for natural gas or 10.0" W.C. for LP.
- Manual gas shut-off valve installed in an accessible location.
- Unit tested and free of gas leaks.

OPERATION

- All internal packing materials removed. Check below grate, pans and drip drawers.
- If used on LP gas, verify that pressure regulator, orifice hoods, air shutters, and valve jets have been set for use with LP gas.
- Grill compartment seated and does not rock (if equipped).
- Bezels centered on burner knobs and knobs turn freely.
- Each burner lights satisfactorily, both individually and with other burners operating at the same time.
- Flame adjustment for 3/8" soft blue cone made on ports of each top burner, low flame adjustment verified.
- Griddle is level and does not rock (if equipped).
- Drip trays are properly in place and pull out freely (if equipped).
- Burner grates correctly positioned, level, and do not rock.
- Griddle flame (see page 17).
- Grill flame (see page 17).
- Cooktop burner flame (see page 17).

HOW TO OBTAIN SERVICE

For warranty service, please contact DCS Customer Care Representative at (888) 936-7872. Before you call, please have the following information ready:

- Model Number (located on the rating plate behind the unit right side)
- Serial Number (located on the rating plate behind the unit right side)
- Date of installation
- A brief description of the problem

Your satisfaction is of the utmost importance to us. If a problem cannot be resolved to your satisfaction, please write to Customer Care or email: customer.care@fisherpaykel.com

Write:

Fisher & Paykel Appliances, Inc.
Attention: DCS Customer Care
5900 Skylab Road
Huntington Beach, CA 92647

BEFORE YOU CALL FOR SERVICE:

1. Is the circuit breaker tripped or the fuse blown?
2. Is there a power outage in the area?

WARRANTY

LIMITED WARRANTY

When you purchase a new DCS Professional Cooktop you automatically receive a One Year Limited Warranty covering parts and labor for the entire product, a Five Year Limited Warranty on surface burners, griddle burners and grill burners (parts only) for servicing within the 48 mainland United States, Hawaii, Washington D.C. and Canada. In Alaska the Limited Warranty is the same except that you must pay to ship the Product to the service shop or the service technician's travel to your home. Products for use in Canada must be purchased through the Canadian distribution channel to ensure regulatory compliance.

FISHER & PAYKEL UNDERTAKES TO:

Repair without cost to the owner either for material or labor any part of the Product, the serial number of which appears on the Product, which is found to be defective. In Alaska, you must pay to ship the Product to the service shop or for the service technician's travel to your home.

If we are unable to repair a defective part of the Product after a reasonable number of attempts, at our option we may replace the part or the Product, or we may provide you a full refund of the purchase price of the Product (not including installation or other charges).

This warranty extends to the original purchaser and any succeeding owner of the Product for products purchased for ordinary single-family home use. All service under this Limited Warranty shall be provided by Fisher & Paykel or its Authorized DCS Service Agent during normal business hours.

HOW LONG DOES THIS LIMITED WARRANTY LAST?

Our liability under this Limited Warranty for the entire product expires One Year from the date of purchase of the Product by the first consumer. Our liability under this Limited Warranty for surface burners, griddle burners, and grill burner (parts only) expires Five Years from the date of the purchase of the Product by the first customer.

Our liability under any implied warranties, including the implied warranty of merchantability (an unwritten warranty that the Product is fit for ordinary use) also expires One Year (or such longer period as required by applicable law) from the date of purchase of the Product by the first consumer. Some states do not allow limitations on how long an implied warranty lasts, so this limit on implied warranties may not apply to you.

THIS WARRANTY DOES NOT COVER:

- A. Service calls that are not related to any defect in the Product. The cost of a service call will be charged if the problem is not found to be a defect of the Product. For example:
 1. Correct faulty installation of the Product.
 2. Instruct you how to use the Product.
 3. Replace house fuses, reset circuit breakers, correct house wiring or plumbing, or replace light bulbs.
 4. Correct fault(s) caused by the user.
 5. Change the set-up of the Product.
 6. Unauthorized modifications of the Product.
 7. Noise or vibration that is considered normal, for example, drain/fan sounds, regeneration noises or user warning beeps.
 8. Correcting damage caused by pests, for example, rats, cockroaches etc.

WARRANTY

- B. Defects caused by factors other than:
 - 1. Normal domestic use or
 - 2. Use in accordance with the Product's User Guide.
- C. Defects to the Product caused by accident, neglect, misuse, fire, flood or Act of God.
- D. The cost of repairs carried out by non-authorized repairers or the cost of correcting such unauthorized repairs.
- E. Travel Fees and associated charges incurred when the product is installed in a location with limited or restricted access. (i.e. airplane flights, ferry charges, isolated geographic areas).
- F. Normal recommended maintenance as set forth in the Product's User Guide.

If you have an installation problem contact your dealer or installer. You are responsible for providing adequate electrical, exhausting and other connection facilities.

We are not responsible for consequential or incidental damages (the cost of repairing or replacing other property damaged if the Product is defective or any of your expenses caused if the Product is defective). Some states do not allow the exclusion or limitation of incidental or consequential damages, so the above limitation or exclusion may not apply to you.

HOW TO GET SERVICE

Please read your User Guide. If you then have any questions about operating the Product, need the name of your local DCS Authorized Service Agent, or believe the Product is

defective and wish service under this Limited Warranty, please contact your dealer or call us at:

TOLL FREE 1-888-936-7872 or contact us through our web site: www.dcsappliances.com

You may be required to provide reasonable proof of the date of purchase of the Product before the Product will be serviced under this Limited Warranty.

COMMERCIAL USE

This warranty applies to appliances used in residential applications; it does not cover their use in commercial situations.

NO OTHER WARRANTIES

This Limited Warranty is the complete and exclusive agreement between you and Fisher & Paykel Appliances Inc. regarding any defect in the Product. None of our employees (or our Authorized Service Agents) are authorised to make any addition or modification to this Limited Warranty.

Warrantor: Fisher & Paykel Appliances, Inc.

If you need further help concerning this Limited Warranty, please call us at the above number, or write to:

Fisher & Paykel Appliances, Inc.
5900 Skylab Road, Huntington Beach, CA 92647

This Limited Warranty gives you specific legal rights, and you may also have other rights which vary from state to state.

Fisher & Paykel Appliances Inc. is a leading manufacturer of premium quality cooking and specialty appliances under the Fisher & Paykel and DCS brands.



Quality provided by Fisher & Paykel Appliances Inc.

Fisher & Paykel Appliances, Inc.
5900 Skylab Road, Huntington Beach, CA 92647
Customer Care: 888.936.7872
Fax: 714.372.7003
www.dcsappliances.com

As product improvement is an ongoing process, we reserve the right to change specifications or design without notice.

Nous améliorons constamment ses produits et se réserve le droit de modifier les spécifications ou la conception de ses produits sans aucun préavis.

P/N 238671 Rev. C
Litho in USA 08/2008