

This Owner's Manual is provided and hosted by [Appliance Factory Parts](#).



Wolf MWD24-2U/S Owner's Manual

[Shop genuine replacement parts for Wolf MWD24-2U/S](#)



[Find Your Wolf Microwave Parts - Select From 13 Models](#)

----- Manual continues below -----

DRAWER MICROWAVE

USE & CARE GUIDE

WOLF[®]



CONTENTS

Wolf Drawer Microwave	3
Safety Instructions and Precautions	4
Wolf Drawer Microwave Features	8
Wolf Drawer Microwave Operation	10
Wolf Drawer Microwave Sensor Cooking	15
Wolf Drawer Microwave Defrost	20
Wolf Drawer Microwave Reheat	22
Wolf Drawer Microwave Cooking Features	23
Wolf Drawer Microwave Care	28
Wolf Troubleshooting	29
Wolf Service Information	30
Wolf Warranty	31

As you read this Use & Care Guide, take particular note of the **CAUTION** and **WARNING** symbols when they appear. This information is important for safe and efficient use of the Wolf equipment.

▲ CAUTION

signals a situation where minor injury or product damage may occur if you do not follow instructions.

▲ WARNING

states a hazard that may cause serious injury or death if precautions are not followed.

In addition, this Use & Care Guide may signal an **IMPORTANT NOTE** which highlights information that is especially important.

THANK YOU

Your purchase of a Wolf drawer microwave attests to the importance you place upon the quality and performance of your cooking equipment. We understand this importance and have designed and built your drawer microwave with quality materials and workmanship to give you years of dependable service.

We know you are eager to start cooking, but before you do, please take some time to read this Use & Care Guide. Whether you are a beginning cook or an expert chef, it will be to your benefit to familiarize yourself with the safety practices, features, operation and care recommendations of the Wolf drawer microwave.

We appreciate your choice of a Wolf Appliance product and welcome any suggestions or comments you may have. To share your opinions with us, please call 800-332-9513.

Your Wolf drawer microwave is protected by a warranty that is one of the finest in the industry. Take a moment to read the warranty statement on page 31 and refer to it should service become necessary.

⚠ WARNING

Read all instructions before using this appliance to reduce the risk of burns, electric shock, fire, injury to persons or exposure to excessive microwave energy.

PRECAUTIONS TO AVOID POSSIBLE EXPOSURE TO EXCESSIVE MICROWAVE ENERGY

- **Do not** attempt to operate this microwave oven with the door open since open-door operation can result in harmful exposure to microwave energy. It is important not to defeat or tamper with the safety interlocks.
- **Do not** place any object between the microwave oven front face and the door or allow soil or cleaner residue to accumulate on sealing surfaces.
- **Do not** operate the microwave oven if it is damaged. It is particularly important that the oven door close properly and that there is no damage to the: (1) door (bent), (2) hinges and latches (broken or loosened), (3) door seals and sealing surfaces.
- The microwave oven should not be adjusted or repaired by anyone except properly qualified service personnel.

GROUNDING INSTRUCTIONS

This appliance must be grounded. This oven is equipped with a cord having a grounding wire with a grounding plug. It must be plugged into a wall receptacle that is properly installed and grounded in accordance with the National Electrical Code and local codes and ordinances. In the event of an electrical short circuit, grounding reduces risk of electric shock by providing an escape wire for the electric current.

⚠ WARNING

Improper use of the grounding plug can result in a risk of electric shock.

ELECTRICAL REQUIREMENTS

The electrical requirements are a 120 volt 60 Hz, AC only, 15 amp. or more protected electrical supply. It is recommended that a separate circuit serving only this appliance be provided.

A short power-supply cord is provided to reduce risk of becoming entangled in or tripping over a longer cord. **DO NOT USE AN EXTENSION CORD.** If the power supply cord is too short, have a qualified electrician or serviceperson install an outlet near the appliance.

NOTES:

- 1) If you have any questions about the grounding or electrical instructions, consult a qualified electrician or serviceperson.
- 2) Neither Wolf nor the dealer can accept any liability for damage to the oven or personal injury resulting from failure to observe the correct electrical connection procedures.

CONTACT INFORMATION

Wolf Customer Service:
800-332-9513

Website:
wolfappliance.com

IMPORTANT SAFETY INSTRUCTIONS AND PRECAUTIONS

READ ALL INSTRUCTIONS BEFORE USING THIS APPLIANCE

When using the appliance, basic safety precautions should be followed, including the following:

WARNING: To reduce the risk of burns, electric shock, fire, injury to persons or exposure to excessive microwave energy:

- **Read this Use and Care Guide carefully** before using your new microwave oven.
- **Read and follow** the specific “PRECAUTIONS TO AVOID POSSIBLE EXPOSURE TO EXCESSIVE MICROWAVE ENERGY” on page 3.
- **This appliance must be grounded.** Connect only to properly grounded outlet. See grounding instructions on page 3.
- **Install or locate this appliance only in accordance** with the provided installation instructions.
- **Some products** such as whole eggs and sealed containers—for example, closed glass jars—**may explode** and should not be heated in this oven.
- **Use this appliance only for its intended use** as described in this manual. Do not use corrosive chemicals or vapors in this appliance. This appliance is specifically designed to heat, cook or dry food. It is not designed for industrial or laboratory use.
- As with any appliance, **close supervision is necessary when used by children.**
- **Do not climb or sit on the appliance.**
- **Do not operate this appliance if it has a damaged cord or plug**, if it is not working properly or if it has been damaged or dropped.
- **This appliance should be serviced only by qualified service personnel.** Contact nearest Wolf authorized service center for examination, repair or adjustment.
- **Do not cover or block any openings** on the appliance.
- **Do not store or use this appliance outdoors.** Do not use this product near water—for example, near a kitchen sink, in a wet basement or near a swimming pool, or similar locations.
- **Do not immerse cord or plug in water.**
- **Keep cord away from heated surfaces.**
- **Be sure that fingers or other objects or materials** are not around the appliance opening when the appliance is closed.
- **Do not put fingers or clothes around the drawer guides** when the appliance is opened or closed. They could be caught in the guides when the appliance is closed.
- **Be sure that the food and container** are shorter than the drawer before closing it. You can refer to the height of the side walls of the drawer.
- **When cleaning appliance sealing surfaces** that come together on closing the drawer, use only mild, nonabrasive soaps or detergents applied with a sponge or soft cloth. See Cleaning and Care on page 28.

TO REDUCE THE RISK OF FIRE IN THE OVEN CAVITY:

- **Do not overcook food.** Carefully attend appliance when paper, plastic or other combustible materials are placed inside the oven to facilitate cooking.
- **Remove wire twist-ties** from paper or plastic bags before placing bag in oven.
- **If materials inside the oven should ignite,** keep appliance door closed, turn microwave off and disconnect the power cord or shut off power at the fuse or circuit breaker panel.
- **Do not use the cavity for storage purposes.** Do not leave paper products, cooking utensils or food in the cavity when not in use.

LIQUIDS

Liquids, such as water, coffee or tea are able to be overheated beyond the boiling point without appearing to be boiling. Visible bubbling or boiling when the container is removed from the microwave oven is not always present. **THIS COULD RESULT IN VERY HOT LIQUIDS SUDDENLY BOILING OVER WHEN A SPOON OR OTHER UTENSIL IS INSERTED INTO THE LIQUID.** To reduce the risk of injury to persons:

- **Do not overheat the liquid.**
- **Stir the liquid** both before and halfway through heating it.
- **Do not use straight-sided containers** with narrow necks. Use a wide-mouthed container.
- **After heating, allow the container to stand in the microwave oven** at least for 20 seconds before removing the container.
- **Use extreme care** when inserting a spoon or other utensil into the container.

SAVE THESE INSTRUCTIONS

INFORMATION YOU NEED TO KNOW

FOOD

- **Check foods to see that they are cooked** to the United States Department of Agriculture's recommended temperatures.
160°F (71°C) – Fresh pork, ground meat, boneless white poultry, fish, seafood, egg dishes and frozen prepared food.
165°F (74°C) – Leftover, ready-to-reheat refrigerated, and deli and carry-out "fresh" food.
170°F (77°C) – White meat of poultry.
180°F (82°C) – Dark meat of poultry.
- **To test for doneness**, insert a meat thermometer in a thick or dense area away from fat or bone. NEVER leave the thermometer in the food during cooking, unless it is approved for microwave oven use.
- **Puncture egg yolks** before cooking to prevent "explosion". Don't cook eggs in shells or reheat whole eggs.
- **Don't dry nuts or seeds in shells.**
- **Pierce skins** of potatoes, apples, squash, hot dogs and sausages so that steam escapes.
- **Use specially bagged popcorn** for the microwave oven. Listen while popping corn for the popping to slow to 1 or 2 seconds or use special **SENSOR POPCORN** pad. Don't exceed the maximum time on popcorn package.
- **Don't pop popcorn in brown bags or glass bowls.**
- **Don't heat baby food in original jars.** Transfer baby food to a small dish and heat carefully, stirring often. Check temperature before serving.

- **Don't heat bottles with nipples on.** Put nipples on bottles after heating and shake thoroughly. "Wrist" test before feeding. Don't heat disposable bottles.
- After heating baked goods with fillings, **pierce outside of food** to release steam and avoid burns.
- **Don't heat or cook in closed glass jars or air tight containers.**
- **Don't preserve foods by canning using the microwave oven**, as harmful bacteria may not be destroyed.
- **Don't deep fat fry.**

CHILDREN

- **Children below the age of 7 should use the microwave oven with a supervising person very near to them.** Children between the ages of 7 and 12 should have a supervising person in the same room.
- **The child must be able to reach the drawer microwave comfortably.**
- **At no time should anyone be allowed to lean or swing on the oven door.**
- **Children should be taught all safety precautions:** use potholders, remove coverings carefully, pay special attention to packages that crisp food because they may be extra hot.
- **Don't assume** that because a child has mastered one cooking skill they can cook everything.
- **Children need to learn that the drawer microwave is not a toy.** See page 25 for CONTROL LOCK feature.

Dimensions in parentheses are in millimeters unless otherwise specified.

GENERAL SAFETY

- **ALWAYS use potholders** to prevent burns when handling utensils that are in contact with hot food. Enough heat from the food can transfer through utensils to cause skin burns.
- **Avoid steam burns** by directing steam away from the face and hands. Slowly lift the farthest edge of a dish's covering and carefully open popcorn and oven cooking bags away from the face.
- **Stay near the drawer microwave** while it's in use and check cooking progress frequently so that there is no chance of overcooking food.
- **NEVER use the cavity for storing cookbooks or other items.**
- **Select, store and handle food carefully** to preserve its high quality and minimize the spread of foodborne bacteria.
- **Keep waveguide cover clean.** Food residue can cause arcing and fires. See page 28.
- **Keep aluminum foil used for shielding** at least 1 inch (25) away from any surface of the drawer microwave. (See page 12 for details.)
- **ALWAYS have food in the microwave oven when it is on** to absorb the microwave energy.
- **The vent under the drawer microwave must not be blocked.** During microwaving, steam may come from the right side of the vent.
- **If the oven light fails,** consult a Wolf authorized service center.
- **Stir liquids briskly** before and after heating to avoid "eruption".
- **Use deep bowl,** when cooking liquids or cereals, to prevent boilovers.
- **Food should be shorter than the drawer microwave.** Please refer to the height of side walls of the drawer.
- **Don't dry wood, gourds, herbs or wet papers.**
- **When using the drawer microwave at power levels below 100%,** you may hear the magnetron cycling on and off. It is normal for the exterior of the oven to be warm to the touch when cooking or reheating.
- **Condensation is a normal part of microwave cooking.** Room humidity and the moisture in food will influence the amount of moisture that condenses in the oven. Generally, covered foods will not cause as much condensation as uncovered ones.
- **The drawer microwave is for food preparation only.** It should not be used to dry clothes or newspapers.
- **Your drawer microwave is rated 950 watts by using the IEC Test Procedure.** In using recipes or package directions, check food a minute or two before the minimum time and add time accordingly.
- When opening or closing the drawer microwave quickly, food in the drawer microwave may be spilled. To clean, please refer to the Cleaning and Care section on page 28.

WOLF DRAWER MICROWAVE FEATURES

DRAWER MICROWAVE FEATURES

- Built-in microwave oven with 950 watts of power
- 30" (762) model allows microwave to be built in to fit below a Wolf built-in E Series oven
- Classic stainless steel finish
- Sensor cooking
- Micro warm allows you to keep food warm up to 30 minutes
- Easy-to-operate control panel and 11 programmable power levels
- Interactive display—99 minutes, 99 seconds
- Oven drawer with window
- Control lock
- Oven light comes on when oven is operating or drawer is open
- Tight drawer seals with automatic drawer open/close

WOLF WARRANTY

Wolf products are covered by a two and five year residential warranty (exclusions apply). See warranty details at the end of this guide.

DRAWER MICROWAVE

Models MWD24-2U/S, MWD30-2U/S and MWD30-2F/S

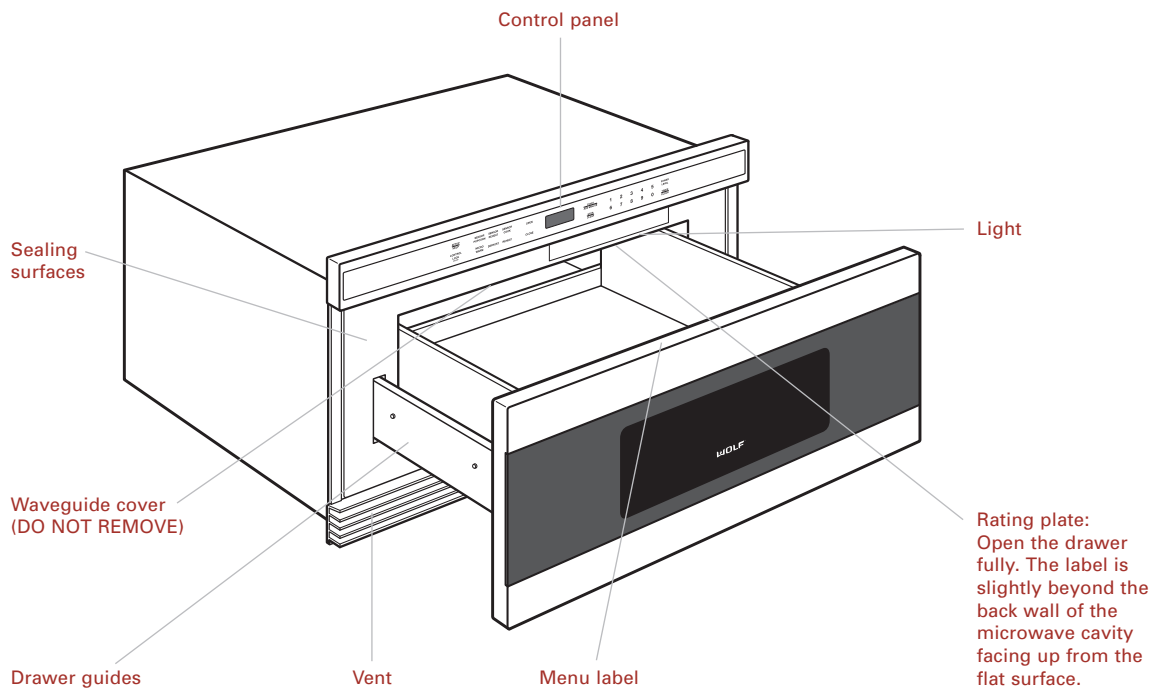

WOLF DRAWER MICROWAVE **FEATURES**

TOUCH **CONTROL PANEL**

The Wolf drawer microwave control panel features touch controls. Refer to the illustration below for the location of control pads.

VISUAL DISPLAY

Words will light in the display to indicate features and cooking instructions.

TOUCH CONTROL PANEL

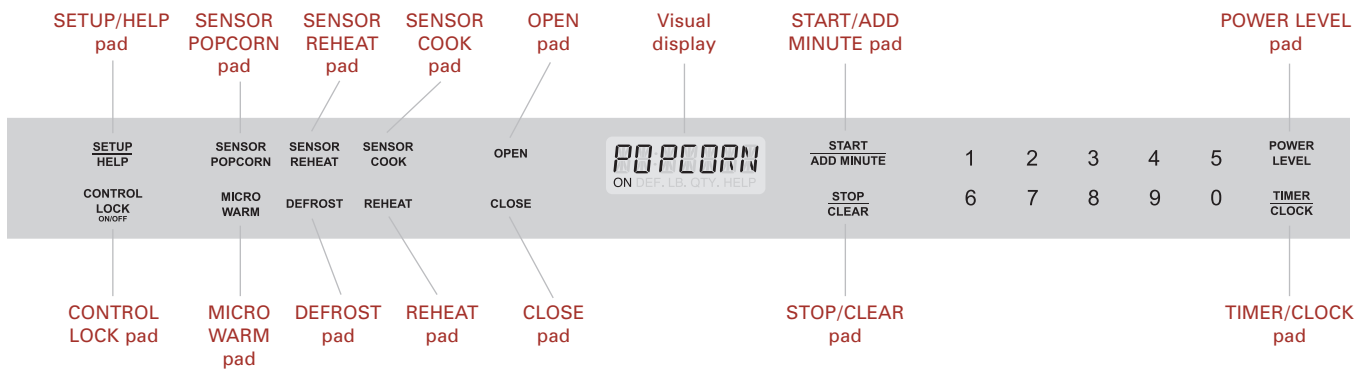

VISUAL DISPLAY



Dimensions in parentheses are in millimeters unless otherwise specified.

UNPACKING YOUR MICROWAVE

- Remove all packing materials from inside the drawer microwave; however, **Do not remove the waveguide cover**, which is located on the top of the drawer microwave, see illustrations below. Read enclosures and save this Use and Care Guide for future reference.
- Remove the feature sticker (if there is one).
- Check the oven for any damage, such as misaligned or bent drawer, damaged drawer seals and sealing surfaces, broken or loose drawer guides and dents inside the cavity or on the front side of the drawer. If there is any damage, do not operate the drawer microwave and contact your dealer or Wolf authorized service center.

RADIO OR TV INTERFERENCE

Should there be any interference caused by the drawer microwave to your radio or TV, check that the drawer microwave is on a different electrical circuit, relocate the radio or TV as far away from the drawer as feasible or check position and signal of receiving antenna.

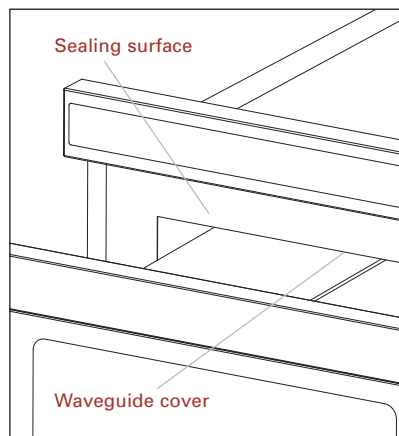

Waveguide cover location

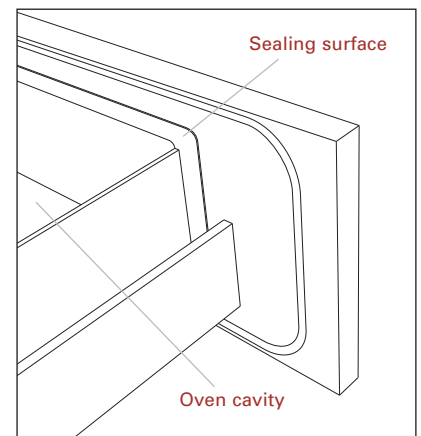

Sealing surface location

ABOUT MICROWAVE COOKING

- **Arrange food carefully.** Place thickest areas towards outside of dish.
- **Watch cooking time.** Cook for the shortest amount of time indicated and add more as needed. Severely overcooked food can smoke or ignite.
- **Cover foods while cooking.** Check recipe or cookbook for suggestions: paper towels, wax paper, microwave plastic wrap or a lid. Covers prevent spattering and help foods to cook evenly.
- **Shield with small flat pieces of aluminum foil** any thin areas of meat or poultry to prevent overcooking before dense, thick areas are cooked thoroughly. (See page 12 for details.)
- **Stir foods from outside to center** of dish once or twice during cooking, if possible.
- **Turn foods over once during microwaving** to speed cooking of such foods as chicken and hamburgers. Large items like roasts must be turned over at least once.
- **Rearrange foods** such as meatballs halfway through cooking both from top to bottom and from right to left.
- **Add standing time.** Remove food from drawer microwave and stir, if possible. Cover for standing time which allows the food to finish cooking without overcooking.
- **Check for doneness.** Look for signs indicating that cooking temperatures have been reached.

SIGNS OF DONENESS

- Food steams throughout, not just at edge.
- Center bottom of dish is very hot to the touch.
- Poultry thigh joints move easily.
- Meat and poultry show no pinkness.
- Fish is opaque and flakes easily with a fork.

COOKWARE SUGGESTIONS

It is not necessary to buy all new cookware. Many pieces already in your kitchen can be used successfully in your new drawer microwave. Make sure the utensil does not touch the interior walls during cooking.

Use these utensils for safe microwave cooking and reheating:

- glass ceramic
- heat-resistant glass
- microwave-safe plastics
- microwave-safe paper plates
- microwave-safe pottery, stoneware and porcelain
- browning dish (Do not exceed recommended preheating time. Follow manufacturer's directions.)

These items can be used for short time reheating of foods that have little fat or sugar in them:

- wood, straw, wicker

DO NOT USE:

- metal pans and bakeware
- dishes with metallic trim
- non-heat-resistant glass
- non-microwave-safe plastics (margarine tubs)
- recycled paper products
- brown paper bags
- food storage bags
- metal twist-ties

The following coverings are ideal:

- **Paper towels** are good for covering foods for reheating and absorbing fat while cooking bacon.
- **Wax paper** can be used for cooking and reheating.
- **Plastic wrap** that is specially marked for microwave use can be used for cooking and reheating. DO NOT allow plastic wrap to touch food. Vent so steam can escape.
- **Lids** that are microwave-safe are a good choice because heat is kept near the food to hasten cooking.
- **Oven cooking bags** are good for large meats or foods that need tenderizing. DO NOT use metal twist ties. Remember to slit bag so steam can escape.

How to use aluminum foil in your drawer microwave:

- Small flat pieces of aluminum foil placed smoothly on the food can be used to shield areas that are either defrosting or cooking too quickly.
- Foil should not come closer than one inch (25) to any surface of the drawer microwave.

IMPORTANT NOTE: To check if a dish is safe for microwaving, place the empty dish in the oven and microwave on HIGH for 30 seconds. If the dish becomes very hot, DO NOT use it for microwaving.

ACCESSORIES

There are many microwave accessories available for purchase. Evaluate carefully before you purchase so that they meet your needs. A microwave-safe thermometer will assist you in determining correct doneness and assure you that foods have been cooked to safe temperatures. Wolf is not responsible for any damage to the drawer microwave when accessories are used.

BEFORE OPERATING

Before operating your new drawer microwave, make certain you read and understand the operation instructions completely.

Before the drawer microwave can be used, follow these steps:

- 1) Plug in drawer microwave. **ENJOY YOUR MICRO-WAVE TOUCH CLEAR AND TOUCH CLOCK** will appear.
- 2) Touch the **STOP/CLEAR** pad. **:** will appear.
- 3) Set clock.

TO SET THE CLOCK

- 1) Touch **TIMER/CLOCK** pad and number **2**.
- 2) Touch number pads for correct time of day and touch **TIMER/CLOCK** pad again.

This is a 12 hour clock. If you attempt to enter an incorrect clock time, **ERROR** will appear in the display. Touch the **STOP/CLEAR** pad and re-enter the time.

If the electrical power supply to your drawer microwave should be interrupted, the display will intermittently show **ENJOY YOUR MICRO-WAVE TOUCH CLEAR AND TOUCH CLOCK** after the power is reinstated. If this occurs during cooking, the program will be erased. The time of day will also be erased. Simply touch the **STOP/CLEAR** pad and reset the clock for the correct time of day.

NOTE: The drawer microwave can be programmed with the drawer open except for **START/ADD MINUTE**.

TIMER

- 1) Touch **TIMER/CLOCK** pad and number **1**.
- 2) Enter time.
- 3) Touch **TIMER/CLOCK** pad again.

To cancel timer, touch **STOP/CLEAR** pad.

STOP/CLEAR

Touch the **STOP/CLEAR** pad to:

- Erase if you make a mistake during programming.
- Cancel timer.
- Stop the drawer microwave temporarily during timed cooking.
- Return the time of day to the display.
- Cancel a program during cooking, touch twice for timed cooking.

OPEN/CLOSE DRAWER MICROWAVE

Always press the **OPEN** or **CLOSE** pad on the control panel to open or close the drawer microwave.

Do not push or pull the drawer microwave by hand, except in case of emergency, such as a power failure. If necessary, push or pull slowly.

TIME COOKING

Your drawer microwave can be programmed for 99 minutes and 99 seconds (99.99). Always enter the seconds after the minutes, even if they are both zeros.

Suppose you want to cook for 5 minutes at 100%.

- 1) Enter cooking time. **5 0 0**

- 2) To cook at 100% power (High), touch **START/ADD MINUTE** pad.

TO SET **POWER LEVEL**

There are eleven preset power levels. Using lower power levels increases the cooking time which is recommended for foods such as cheese, milk and long slow cooking of meats. Consult a microwave cookbook or recipes for specific recommendations.

Suppose you want to defrost for 5 minutes at 30%.

- 1) Enter defrost time **5 0 0**.

- 2) Touch **POWER LEVEL** pad 8 times.

- 3) Touch **START/ADD MINUTE** pad.

Touch Power

Level Pad	% Power	Level
1 time	100%	High
2 times	90%	
3 times	80%	
4 times	70%	Medium High
5 times	60%	
6 times	50%	Medium
7 times	40%	
8 times	30%	Med Low/Defrost
9 times	20%	
10 times	10%	Low
11 times	0%	

SENSOR COOKING

Wolf's sensor is a semi-conductor device that detects the vapor (moisture and humidity) emitted from the food as it heats. The sensor adjusts the cooking times and power levels for various foods and quantities.

USING SENSOR SETTINGS

- After the drawer microwave is plugged in, wait 2 minutes before using any **SENSOR** setting.
- Be sure the exterior of the cooking container and the interior of the drawer microwave are dry. Wipe off any moisture with a dry cloth or paper towel.
- The sensor works with foods at normal storage temperature. For example, popcorn would be at room temperature.
- Any **SENSOR** selection can be programmed with More or Less Time Adjustment. See page 25.
- More or less food than the quantity listed in the **Sensor Cooking Guide** should be cooked following the guidelines in any microwave cookbook.
- During the first part of sensor use, the food name will appear on the display. Do not open the drawer microwave or touch **STOP/CLEAR** during this part of the cycle. The measurement of vapor will be interrupted. If this occurs, an error message will appear. To continue cooking, touch the **STOP/CLEAR** pad and cook manually.
- When the sensor detects the vapor emitted from the food, the remainder of cooking/reheating time will appear. The drawer microwave may be opened when the remaining time appears on the display. At this time, you may stir or season food, as desired.
- If the sensor does not detect vapor properly when popping popcorn, the oven will turn off, and the time of day will be displayed. If the sensor does not detect vapor properly when cooking other foods, **ERROR** will be displayed, and the microwave will turn off.
- Check food temperature after cooking. If additional time is needed, continue to cook manually.
- Each food has a cooking hint. Touch the **HELP** pad when the **HELP** indicator is lighted in the display.

SENSOR COOKING**COVERING FOODS**

Some foods work best when covered. Use the cover recommended in the **Sensor Cooking Guide** for these foods. Be careful when removing any covering to allow steam to escape away from you. You may refer to the hints by touching the **HELP** pad. See page 24.

- **Casserole dish lid.**
- **Plastic wrap:** Use plastic wrap recommended for microwave cooking. Cover dish loosely; allow approximately 1/2 inch (13) to remain uncovered to allow steam to escape. Plastic wrap should not touch food.
- **Wax paper:** Cover dish completely; fold excess wrap under dish to secure. If dish is wider than paper, overlap two pieces at least one inch (25) to cover.

SENSOR POPCORN/SENSOR REHEAT

You can pop popcorn and reheat many foods and don't need to calculate cooking time or power level.

Touch **SENSOR POPCORN** or **SENSOR REHEAT** and **START/ADD MINUTE** pad.

When the sensor detects the vapor emitted from the food, the remainder of cooking/reheating time will appear.

NOTE:

- The **SENSOR POPCORN** setting has 2 choices. Follow directions in the display to choose desired option.

TO SENSOR COOK:

- 1) Touch **SENSOR COOK** pad once.
- 2) See Menu Label. Select desired food by touching number pad. Example: Touch **5** for baked potatoes.
- 3) Touch **START/ADD MINUTE** pad.

NOTE:

- To heat or cook other foods or foods above or below the quantity allowed on the **Sensor Cooking Guide**, cook manually.

SENSOR POPCORN / SENSOR REHEAT COOKING GUIDE

FOOD	AMOUNT	PROCEDURE
Sensor Popcorn	Only 1 package at a time	Use only popcorn packaged for the microwave. Try several brands to decide which you like. Do not try to pop unpopped kernels.
	Regular/Regular light 2.85–3.5 oz bag (81–100 g)	Touch Sensor/Popcorn pad once.
	Mini/Snack 1.2–1.75 oz bag (34–50 g)	Touch Sensor/Popcorn pad twice.
Sensor Reheat	4–36 oz (110–1000 g)	Place in dish or casserole slightly larger than amount to be reheated. Flatten, if possible. Cover with lid, plastic wrap or wax paper. Use covers such as plastic wrap or lids with larger quantities of more dense foods such as stews. After reheating, stir well, if possible. Re-cover and allow to stand 2 to 3 minutes. Foods should be very hot. If not, continue to heat with variable power and time.

Dimensions in parentheses are in millimeters unless otherwise specified.

SENSOR COOKING GUIDE

NO.	FOOD	AMOUNT	PROCEDURE
1	Fresh Vegetables (Soft) Broccoli Brussels Sprouts Cabbage Cauliflower (flowerettes) Cauliflower (whole) Spinach Zucchini Baked Apples	$\frac{1}{4}$ –2 lb (110–900 g) $\frac{1}{4}$ –2 lb (110–900 g) $\frac{1}{4}$ –2 lb (110–900 g) $\frac{1}{4}$ –2 lb (110–900 g) 1 medium $\frac{1}{4}$ –1 lb (110–450 g) $\frac{1}{4}$ –2 lb (110–900 g) 2–4 medium	Wash and place in microwave-safe casserole. Add no water if vegetables have just been washed. Cover with lid for tender vegetables. Use plastic wrap for tender-crisp vegetables. After cooking, stir, if possible. Let stand for 2–5 minutes, covered.
2	Fresh Vegetables (Hard) Carrots (sliced) Corn on the Cob Green Beans Winter Squash (diced) Winter Squash (halves)	$\frac{1}{4}$ –1 $\frac{1}{2}$ lb (110–675 g) 2–4 pieces $\frac{1}{4}$ –1 $\frac{1}{2}$ lb (110–675 g) $\frac{1}{4}$ –1 $\frac{1}{2}$ lb (110–675 g) 1–2	Place in microwave safe casserole. Add 1–4 tablespoons (15–60 ml) water. Cover with lid for tender vegetables. Use plastic wrap cover for tender-crisp vegetables. After cooking, stir, if possible. Let stand for 2–5 minutes, covered.
3	Frozen Vegetables	$\frac{1}{4}$ –1 $\frac{1}{4}$ lb (110–567 g)	Add no water. Cover with lid or plastic wrap. After cooking, stir and let stand for 3 minutes, covered.
4	Frozen Entrees	6–17 oz (200–500 g)	Use for frozen convenience foods. It will give satisfactory results for most brands. You may wish to try several and choose your favorite. Remove package from outer wrapping and follow package directions for covering. After cooking, let stand for 1–3 minutes, covered.

SENSOR COOKING GUIDE

NO.	FOOD	AMOUNT	PROCEDURE
5	Baked Potatoes	1–6 medium	Pierce. Place on paper-towel-lined drawer microwave. After cooking, remove from microwave, wrap in aluminum foil and let stand for 5–10 minutes.
6	Ground Meat	1/4–2 lb (110–900 g)	Use this setting to cook ground beef or turkey as patties or in a casserole to be added to other ingredients. Place patties on a microwave-safe rack and cover with wax paper. Place ground meat in a casserole and cover with wax paper or plastic wrap. When microwave stops, turn patties over or stir meat in casserole to break up large pieces. Re-cover and touch START/ADD MINUTE pad. After cooking, let stand for 2–3 minutes, covered.
7	Fish, Seafood	1/4–2 lb (110–900 g)	Arrange in ring around shallow microwave-safe glass dish (roll fillet with edges underneath). Cover with vented plastic wrap. After cooking, let stand for 3 minutes, covered.
8	Rice	1/2–2 c (95–380 g)	Place rice into a deep casserole dish and add double quantity of water. Cover with lid or plastic wrap. After cooking, stir, cover and let stand 3–5 minutes or until all liquid has been absorbed.

Rice	Water	Dish
1/2 c (95 g)	1 c (240 ml)	1 1/2 qt (1.5 L)
1 c (190 g)	2 c (480 ml)	2 qt (2 L)
1 1/2 c (285 g)	3 c (720 ml)	2 1/2 (2.5 L) or 3 qt (3 L)
2 c (380 g)	4 c (1 L)	3 qt (3 L) or larger

Dimensions in parentheses are in millimeters unless otherwise specified.

DEFROST

Use this feature to defrost the foods shown in the **Defrost Guide** on the following page.

- 1) Touch **DEFROST** pad.
- 2) See Menu Label. Select desired food by touching the number pad. Example:
Touch **2** for steaks/chops.
- 3) Enter weight by touching number pads.
- 4) Touch **START/ADD MINUTE** pad. The oven will stop so that the food can be checked.
- 5) After the first stage, open the drawer microwave. Turn steak over and shield any warm portions. Close the drawer microwave. Touch **START/ADD MINUTE** pad.
- 6) After the second stage, open the drawer microwave. Shield any warm portions. Close the drawer microwave. Touch **START/ADD MINUTE** pad.
- 7) After defrost cycle ends, cover and let stand as indicated in the **Defrost Guide** on the following page.

NOTES:

- DEFROST can be programmed with More or Less Time Adjustment. See page 25.
- To defrost other foods or foods above or below the weights allowed on the **Defrost Guide**, see "Manual Defrost".
- Check foods when oven signals. After final stage, small sections may still be icy. Let stand to continue thawing. Do not defrost until all ice crystals are thawed.
- Shielding prevents cooking from occurring before the center of the food is defrosted. Use small smooth strips of aluminum foil to cover edges and thinner sections of the food.

MANUAL DEFROST

If the food that you wish to defrost is not listed on the **Defrost Guide** or is above or below the limits in the "Amount" column on the **Defrost Guide**, you need to defrost manually.

You can defrost any frozen food, either raw or previously cooked, by using POWER LEVEL at 30%. Follow the exact 3-step procedure found under "To Set Power Level" on page 14. Estimate defrosting time and press **POWER LEVEL** pad eight times for 30% power.

For either raw or previously cooked frozen food, the rule of thumb is approximately 4 minutes per pound (.45 kg). For example, defrost 4 minutes for 1 pound (.45 kg) of frozen spaghetti sauce.

Always stop the oven periodically to remove or separate the portions that are defrosted. If food is not defrosted at the end of the estimated defrosting time, program the oven in 1 minute increments on POWER LEVEL 30% until totally defrosted.

When using plastic containers from the freezer, defrost only long enough to remove from the plastic in order to place in a microwave-safe dish.

DEFROST GUIDE

NO.	FOOD	AMOUNT	PROCEDURE
1	Ground Meat	$\frac{1}{2}$ –2 lb (200–900 g)	Remove any thawed pieces after each audible signal. Let stand for 5–10 minutes, covered.
2	Steaks, Chops	$\frac{1}{2}$ –3 lb (200–1400 g)	After each audible signal, rearrange. If there are warm or thawed portions, shield with small flat pieces of aluminum foil. Remove any meat that is almost defrosted. Let stand for 10–20 minutes, covered.
3	Boneless Poultry	$\frac{1}{2}$ –2 lb (200–900 g)	After each audible signal, rearrange pieces or remove should they become warm or thawed. Let stand for 10–20 minutes, covered.
4	Bone-in Poultry	$\frac{1}{2}$ –3 lb (200–1400 g)	After each audible signal, rearrange pieces or remove should they become warm or thawed. Let stand for 10–20 minutes, covered.
5	Casserole, Soup	1–6 c (.25–1.5 L)	After each audible signal, break apart and remove any defrosted part. At end, stir well and let stand for 5–10 minutes, covered.

Dimensions in parentheses are in millimeters unless otherwise specified.

REHEAT

REHEAT automatically computes the correct warming time and microwave power level for foods shown in the **Reheat Guide** below.

- 1) Touch **REHEAT** pad once.
- 2) See Menu Label. Select desired food by touching number pad. Example: Touch **2** for frozen rolls or muffins.
- 3) Touch the number pad to select quantity. Example: Touch **2** for 2 rolls or muffins.
- 4) Touch **START/ADD MINUTE** pad.

NOTES:

- REHEAT can be programmed with More or Less Time Adjustment. See page 25.
- To reheat other foods or foods above or below the quantity allowed on the **Reheat Guide**, heat manually.

REHEAT GUIDE

NO.	FOOD	AMOUNT	PROCEDURE
1	Fresh Rolls, Muffins	1–8 pieces	Use to warm rolls, muffins, biscuits, bagels etc. Large items should be considered as 2 or 3 regular size. Arrange on plate; cover with paper towel. For refrigerated rolls or muffins, it may be necessary to double the entered amount to ensure the proper serving temperature. For example, enter quantity of 2 for 1 refrigerated muffin.
2	Frozen Rolls, Muffins	1–8 pieces	Use to warm frozen rolls, muffins, biscuits, bagels etc. Large items should be considered as 2 or 3 regular size. Arrange on plate; cover with paper towel.
3	Beverage	1/2–2 c (125–500 ml)	This setting is good for restoring cooled beverage to a better drinking temperature. Stir liquid briskly before and after heating to avoid “eruption”.

MICRO WARM

MICRO WARM allows you to keep food warm up to 30 minutes.

DIRECT USE

- 1) Touch **MICRO WARM** pad.
- 2) Enter desired time by touching the number pads. To enter 30 minutes, touch **3 0 0 0**.
- 3) Touch **START/ADD MINUTE** pad. The oven will start. The display will show and count down. will be displayed intermittently during the count down.

MANUAL COOKING

- 1) Enter desired cooking time and power level.
- 2) Touch **MICRO WARM** pad.
- 3) Enter desired warming time up to 30 minutes.
- 4) Touch **START/ADD MINUTE** pad. The operation will start. When the cooking time is complete, a long tone will sound and MICRO WARM will start. The display will count down. will be displayed intermittently during the count down.

NOTES:

- If you attempt to enter more than 30 minutes for MICRO WARM, an error message will appear in the display.
- MICRO WARM cannot be programmed with SENSOR POPCORN, SENSOR REHEAT, SENSOR COOK, DEFROST or REHEAT.

MULTIPLE SEQUENCE COOKING

Your drawer microwave can be programmed for up to 4 automatic cooking sequences, switching from one power level setting to another automatically.

Sometimes cooking directions tell you to start on one power level and then change to a different power level. Your drawer microwave can do this automatically.

- 1) First enter cooking time. Then touch **POWER LEVEL** pad once for 100% cooking or repeat touching **POWER LEVEL** pad for a lower power level.
- 2) Enter second cooking time. Repeat touching **POWER LEVEL** pad for desired level. You can follow this procedure up to 4 times.
- 3) Touch **START/ADD MINUTE** pad.

NOTES:

- If **POWER LEVEL** pad is touched once, will be displayed.
- If 100% is selected as the final sequence, it is not necessary to touch the **POWER LEVEL** pad.
- If you wish to know power level during cooking, simply touch the **POWER LEVEL** pad. As long as your finger is touching the **POWER LEVEL** pad, the power level will be displayed.
- MICRO WARM can be programmed even if 4 cooking sequences have been set.

HELP FEATURE

Each setting of SENSOR REHEAT, SENSOR COOK, SENSOR POPCORN, MICRO WARM, REHEAT and DEFROST has a cooking hint. If you wish to check, touch **HELP** whenever HELP is lighted in the Interactive Display for these and other manual operation hints.

ADD MINUTE

ADD MINUTE allows you to cook for a minute at 100% by simply touching the **ADD MINUTE** pad. You can also extend cooking time in multiples of 1 minute by repeatedly touching the **ADD MINUTE** pad during manual cooking.

NOTES:

- To use ADD MINUTE, touch the **ADD MINUTE** pad within 3 minutes after cooking, closing the door or touching the **STOP/CLEAR** pad.
- ADD MINUTE cannot be used with SENSOR settings, REHEAT or DEFROST.

MORE OR LESS TIME ADJUSTMENT

Should you discover that you like any of the **SENSOR**, **REHEAT** or **DEFROST** settings slightly more done, touch the **POWER LEVEL** pad once after touching your selection. The display will show **MORE**.

For slightly less done, touch the **POWER LEVEL** pad twice after touching your selection. The display will show **LESS**.

CONTROL LOCK

The **CONTROL LOCK** prevents unwanted drawer operation such as by small children. The drawer microwave can be set so that the control panel is deactivated or locked.

TO LOCK

Touch **CONTROL LOCK** pad and hold for 3 seconds. The display shows **LOCK ON**.

TO UNLOCK

Touch **CONTROL LOCK** pad and hold for 3 seconds. The display shows **LOCK OFF**.

SETUP/HELP

If the electrical power supply to your drawer microwave should be interrupted, the display will intermittently show **ENJOY YOUR MICRO-WAVE TOUCH CLEAR AND TOUCH CLOCK** after the power is reinstated. If this occurs, the **SETUP/HELP** option you input will be erased. Simply touch **STOP/CLEAR** pad and reset.

AUDIBLE SIGNAL ELIMINATION

At the end of timed cook, beeps will sound. If you wish to have the appliance with no audible signals, you can turn the audible signals off.

To turn sound off:

- 1) Touch **SETUP/HELP** pad.
TOUCH AGAIN
- 2) Touch **SETUP/HELP** pad again.
SOUND OFF ? TOUCH START
- 3) Touch **START/ADD MINUTE** pad.
The display shows **SOUND OFF**.

To restore sound:

- 1) Touch **SETUP/HELP** pad.
TOUCH AGAIN
- 2) Touch **SETUP/HELP** pad again.
SOUND ON ? TOUCH START
- 3) Touch **START/ADD MINUTE** pad.
The display shows **SOUND ON**.

END OF COOKING REMINDER

At end of timed cooking, the microwave will signal every 10 seconds for the first minute; then every 3 minutes until **STOP/CLEAR** pad is touched, up to one hour.

To turn reminder off:

- 1) Touch **SETUP/HELP** pad three times.
The display shows **REMIND SIGNAL OFF ? TOUCH START**.
- 2) Touch **START/ADD MINUTE** pad. The display shows **REMIND SIGNAL OFF**.

To turn reminder signal back on:

- 1) Touch **SETUP/HELP** pad three times.
The display shows **REMIND SIGNAL ON ? TOUCH START**.
- 2) Touch **START/ADD MINUTE** pad. The display shows **REMIND SIGNAL ON**.

SETUP/HELP**AUTO START**

If you wish to program the drawer microwave to begin cooking automatically at a designated time of day, follow this procedure.

- 1) Touch **SETUP/HELP** pad 4 times.
The display shows .
 - 2) Touch **START/ADD MINUTE** pad.
 - 3) Enter start time.
 - 4) Touch **TIMER/CLOCK** pad.
 - 5) Touch the number pads to enter cooking time.
- Touch **POWER LEVEL** pad repeatedly until the desired power level is reached.
- 6) Touch **START/ADD MINUTE** pad.

DEMONSTRATION MODE**To select Demo Mode:**

- 1) Touch **SETUP/HELP** pad five times.
The display shows .
- 2) Hold **START/ADD MINUTE** pad for 3 seconds. The display shows .

To cancel Demo Mode:

- 1) Hold **SETUP/HELP** pad five times.
The display shows .
- 2) Touch **START/ADD MINUTE** pad. The display shows .

NOTES:

- Drawer microwave doesn't heat in Demo Mode.
- Display counts down quickly.

CLEANING AND CARE

STAINLESS STEEL SURFACE

The exterior should be wiped often with a soft damp cloth and polished with a soft dry cloth to maintain its beauty. There are also a variety of products designed especially for cleaning and shining the stainless exterior of the oven. We recommend that the cleaner be applied to a soft cloth and then carefully used on the stainless exterior rather than sprayed directly on to it. Follow package directions carefully.

FRONT SIDE OF THE DRAWER

Wipe the window on both sides with a soft damp cloth to remove any spills or splatters. Metal parts will be easier to maintain if wiped frequently with a soft damp cloth. Avoid the use of spray and other harsh cleaners as they may stain, streak or dull the door surface.

TOUCH CONTROL PANEL

If desired, the touch pads may be deactivated before cleaning. See the CONTROL LOCK information on page 25 of this manual. Wipe the panel with a cloth dampened slightly with water only. Dry with a soft cloth. Do not scrub or use any sort of chemical cleaners. Close door and follow directions on page 25 for turning CONTROL LOCK off. Touch **STOP/CLEAR**.

INTERIOR

Cleaning is easy because no heat is generated to the interior surfaces; therefore, there is no baking and setting of spills or spattering. To clean the interior surfaces, including drawer sealing surfaces, wipe with a soft damp cloth. **Do not use abrasive or harsh cleaners or scouring pads.** For heavier soil, use mild soap; wipe clean with a soft damp cloth. Do not use any chemical oven cleaners.

DRAWER GUIDES

Remove the food crumbs from the drawer guides. Wipe with a soft dry cloth in order to keep the drawer microwave opening and closing smoothly.

▲ CAUTION

The waveguide cover, located on the inside top of the drawer microwave area, is made from mica, so it requires special care. Keep the waveguide cover clean to assure good microwave performance. Carefully wipe with a soft damp cloth any food splatters from the surface of the cover immediately after they occur. Built-up splashes may overheat and cause smoke or possibly catch fire. Do not remove the waveguide cover.

ODOR REMOVAL

Occasionally, a cooking odor may remain in the drawer microwave. To remove, combine 1 cup (250 ml) water, grated peel and juice of one lemon and several whole cloves in a 2-cup (500 ml) glass measuring cup. Boil for several minutes using 100% power. Allow to set in the drawer microwave until cool. Wipe interior with a soft cloth.

TROUBLESHOOTING GUIDE

PROBLEM	POSSIBLE CAUSE	SOLUTION
Part of all of drawer microwave does not operate.	Power cord of drawer microwave is not completely connected to the electrical outlet.	Make sure the power cord is tightly connected to the outlet.
	Power outage.	Check house lights to be sure. Call your local electric company for service.
	Fuse/circuit breaker at home doesn't work.	Replace the fuse or reset the circuit breaker.
	Drawer microwave is in Demo Mode.	See page 27 for how to cancel Demo Mode.
Food in drawer microwave is not heated.	No power to the appliance.	See SOLUTION for PROBLEM 1.
	Drawer controls improperly set.	Check if the controls have been properly set.
	Drawer is in Demo Mode.	See page 27.
Drawer microwave light does not work.	Light bulb is loose or burned out.	Call for service.
Touch controls will not operate.	CONTROL LOCK is on.	See page 25 to unlock.
Display flashes.	Power failure.	Press Clear pad and reset the clock. If the drawer microwave was in use, you must reset the cooking function.
Steam from the vent.	During microwaving, steam may come from the right side of the vent.	

Dimensions in parentheses are in millimeters unless otherwise specified.

SERVICE INFORMATION

When requesting information, literature, replacement parts or service, always refer to the model and serial number of your microwave oven. This information is found on the product rating plate. Refer to page 8 for the location of the rating plate.

Record the rating plate information below for future reference.

Model Number _____

Serial Number _____

Installation Date _____

Wolf Authorized Service Center and Phone

Wolf Dealer and Phone

BEFORE CALLING FOR SERVICE

Before calling your Wolf authorized service center, check the household fuse or circuit breaker to see if it has been blown or tripped and that the electrical connection to the appliance has not been disconnected. A power outage may also have caused a disruption in service.

PRODUCT REGISTRATION

Register your new Wolf product today so that we may ensure your satisfaction. You may register by one of the following options:

- 1) Mail in the completed Wolf Product Registration Card.
- 2) Register online at **wolfappliance.com**.
- 3) Register by phone by calling the Wolf Customer Service Department at **800-332-9513**.

The model and serial numbers of your appliance are printed on the enclosed Wolf Product Registration Card. If you provide us with your e-mail address, we will send you exciting new product updates and recipes as they become available, along with information on special events.

The information and images in this book are the copyright property of Wolf Appliance, Inc., an affiliate of Sub-Zero, Inc. Neither this book nor any information or images contained herein may be copied or used in whole or in part without the express written permission of Wolf Appliance, Inc., an affiliate of Sub-Zero, Inc.

©Wolf Appliance, Inc. all rights reserved.

CONTACT
INFORMATION

**Wolf Customer
Service:
800-332-9513**

**Website:
wolfappliance.com**

Wolf Appliance Products Limited Warranty

RESIDENTIAL USE ONLY

FULL TWO YEAR WARRANTY*

For two years from the date of original installation, your Wolf Appliance product warranty covers all parts and labor to repair or replace any part of the product that proves to be defective in materials or workmanship. All service provided by Wolf Appliance under the above warranty must be performed by a Wolf Appliance authorized service center, unless otherwise specified by Wolf Appliance. Service will be provided in the home during normal business hours.

LIMITED THIRD THROUGH FIFTH YEAR WARRANTY

From the third through fifth year from the date of original installation, Wolf Appliance will repair or replace the following parts that prove to be defective in materials or workmanship. Labor to remove and replace defective parts is not covered. Wolf Appliance recommends that you use a Wolf Appliance authorized service center to perform such service.

Gas Burners (excluding appearance), Electric Heating Elements, Blower Motors (vent hoods), Electronic Control Boards, Magnetron Tubes and Induction Generators

LIMITED LIFETIME WARRANTY

For the life of the product, Wolf Appliance will repair or replace any outdoor gas grill body or hood that rusts through due to defective material or workmanship. Labor to remove and replace defective parts is not covered. Wolf Appliance recommends that you use a Wolf Appliance authorized service center to perform such service.

TERMS APPLICABLE TO EACH WARRANTY

The warranty applies only to products installed for normal residential use. The warranty applies only to products installed in any one of the fifty states of the United States, the District of Columbia or the ten provinces of Canada. This warranty does not cover any parts or labor to correct any defect caused by negligence, accident or improper use, maintenance, installation, service or repair.

THE REMEDIES DESCRIBED ABOVE FOR EACH WARRANTY ARE THE ONLY ONES THAT WOLF APPLIANCE, INC. WILL PROVIDE, EITHER UNDER THIS WARRANTY OR UNDER ANY WARRANTY ARISING BY OPERATION OF LAW. WOLF APPLIANCE, INC. WILL NOT BE RESPONSIBLE FOR ANY CONSEQUENTIAL OR INCIDENTAL DAMAGES ARISING FROM THE BREACH OF THIS WARRANTY OR ANY OTHER WARRANTY, WHETHER EXPRESS, IMPLIED OR STATUTORY.

Some states do not allow the exclusion or limitation of incidental or consequential damages, so the above limitation or exclusion may not apply to you. This warranty gives you specific legal rights and you may also have other legal rights that vary from state to state.

To receive parts and/or service and the name of the Wolf Appliance authorized service center nearest you, contact Wolf Appliance, Inc., P.O. Box 44848, Madison, Wisconsin 53744; check the Contact & Support section of our website, wolfappliance.com, or call 800-332-9513.

*Stainless Steel (classic, platinum and carbon) doors, panels and product frames are covered by a limited 60 day parts and labor warranty for cosmetic defects.



WOLF APPLIANCE, INC. P. O. BOX 44848 MADISON, WI 53744 800-332-9513 WOLFAPPLIANCE.COM

WOLF[®]

813534 REV-B TINSEB508MRR2



11/2008