

This Owner's Manual is provided and hosted by [Appliance Factory Parts](#).



Sams ST1017-012939 Owner's Manual

[Shop genuine replacement parts for Sams
ST1017-012939](#)



[Find Your Sams Grill Parts - Select From 92 Models](#)

----- Manual continues below -----

8 Burners Event Grill

Model: ST1017-012939

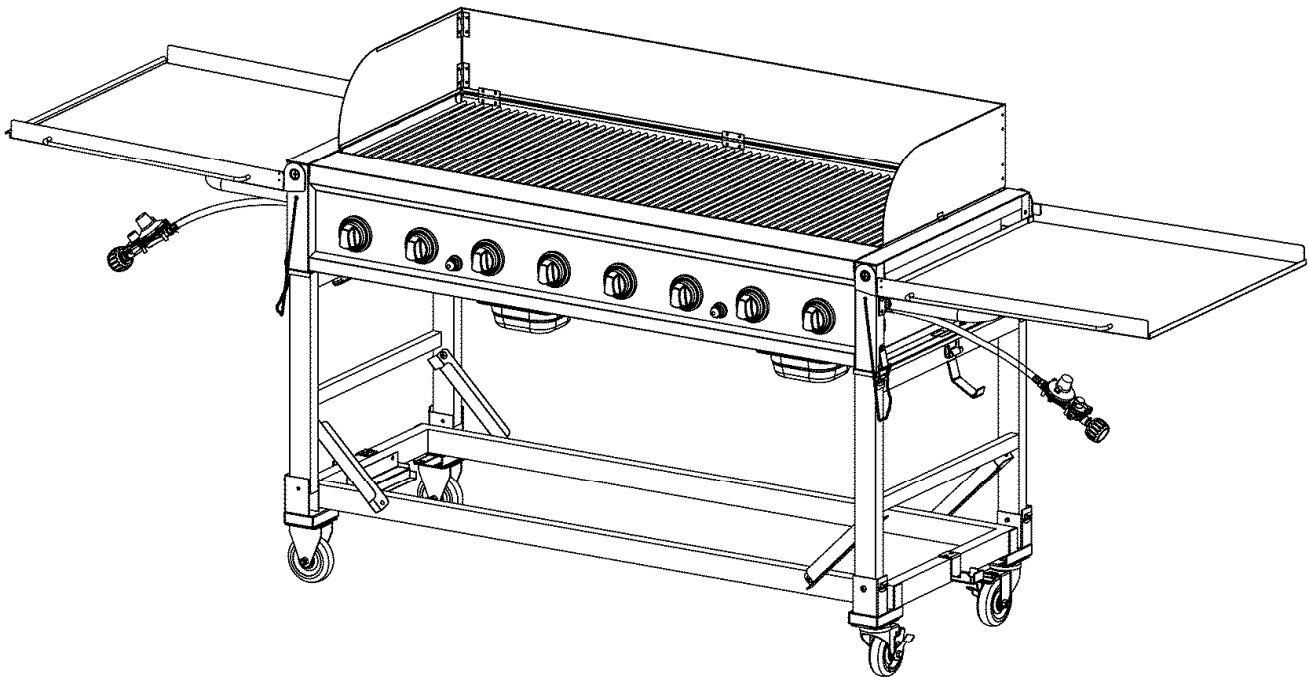

OPERATOR'S MANUAL

For Outdoor Use Only

Thank you for purchasing this outdoor cooking appliance.

Please read Safety and Precaution statements, Grill Maintenance, Leak Testing Regulator / Cylinder connection and Lighting Grill before using grill for first time,

- This instruction manual contains important information necessary for the proper assembly and safe use of the appliance.
- Read and follow all warnings and instructions before assembling and using the appliance.
- Follow all warnings and instructions when using the appliance.
- Keep these manual for further reference.

As RanKam we 're the experts on this product and trained to help you with:

Assembly Questions

Grill operation

Replacements of damaged or missing parts, please contact

Toll Free 1-888-837-1380

 **DANGER** 

If you smell gas:

1. Shut off gas to the appliance.
2. Extinguish any open flame.
3. If odor continues, keep away from the appliance and immediately call your gas supplier or your fire department.

 **WARNING** 

FOR YOUR SAFETY
Do not store or use gasoline or other flammable vapors or liquids in the vicinity of this or any other appliance.

 **WARNING** 

Improper installation, adjustment, alteration, service or maintenance can cause property damage, injury or death. Read the installation, operating and maintenance instructions thoroughly before installing or servicing this equipment.

 **WARNING** 

For Outdoor Use Only.
If Stored Indoors, Detach and Leave Cylinder(s) Outdoors.
LP-gas supply cylinder must be disconnected when the appliance is not in use.
Do not locate this appliance under overhead unprotected combustible surfaces.

- This appliance shall be used only outdoors, in well-ventilated. Never use this grill in a garage, porch, shed, breezeway or any other enclosed area.
- Never put cylinder(s) under grill body in any time.
- Never obstruct the flow of ventilation air around this grill housing.
- Never disconnect the gas regulator or any gas fitting while this grill is lit. A lit grill can ignite leaking gas and cause a fire or explosion which could result in property damage, personal injury or death.

Grill Installation Codes

The installation and pressure regulator must conform with local codes, or in the absence of local codes, with the *National Fuel Gas Code, ANSI Z223.1/NFPA 54*, or the *Natural Gas and Propane Installation Code, CSA B149.1*, as applicable, including:

1. The appliance and its individual shutoff valve must be disconnected from the gas supply piping system during any pressure testing of that system at test pressures in excess of 1/2 psi (3.5 kPa).
2. The appliance must be isolated from the gas supply piping system by closing its individual manual shutoff valve during any pressure testing of the gas supply piping system at test pressures equal to or less than 1/2 psi (3.5 kPa).



Casters Installation Code

The installation shall be made with a connector that complies with the Standard for Connectors for Movable Gas Appliances, ANSI Z21.69-CSA6.16, and a quick disconnect device that complies with Standard for Quick –Disconnect Devices for Use With Gas Fuel, ANSIZ21.41.CSA6.9.

To expedite the assembly processes follow these general guidelines:

- Tools required for Assembly:
 1. Protective work gloves
 2. Protective eyewear
 3. Phillips Head Screwdriver
- You will need assistance from another person to handle the grill head and other large, heavy parts.
- Open Lid of shipping carton and remove top sheet of cardboard and / or packing materials. Lay cardboard sheet on floor and use as a work surface to protect floor and grill parts from scratches.
- You may slice the carton front corners with a utility knife to lay open the carton front panel. This allows you to raise the grill head Lid and remove the components packed inside, making it easier to lift.
- Use of Hardware and Part Diagrams to ensure all items are included and free of damage.
- NOTE: This gas grill is designed to be used with two 20lb LP Gas tanks (not included) for 8 burner operation. A tank placed on the right will operate the four right-side burners. A tank placed on the left will operate the four left-side burners.

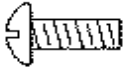
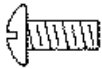
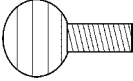
Hardware list

No	Description	Qty	Diagram
#1	Phillips Head Screws 1/4" x 15mm	16	
#2	Phillips Head Screws 1/4" x 12mm	16	
#3	Thumbscrew 1/4" x 13mm	4	
#4	Phillips Head Screws 3/16" x 8mm	4	
#5	Washer Ø18 x Ø7 x 1mm	4	



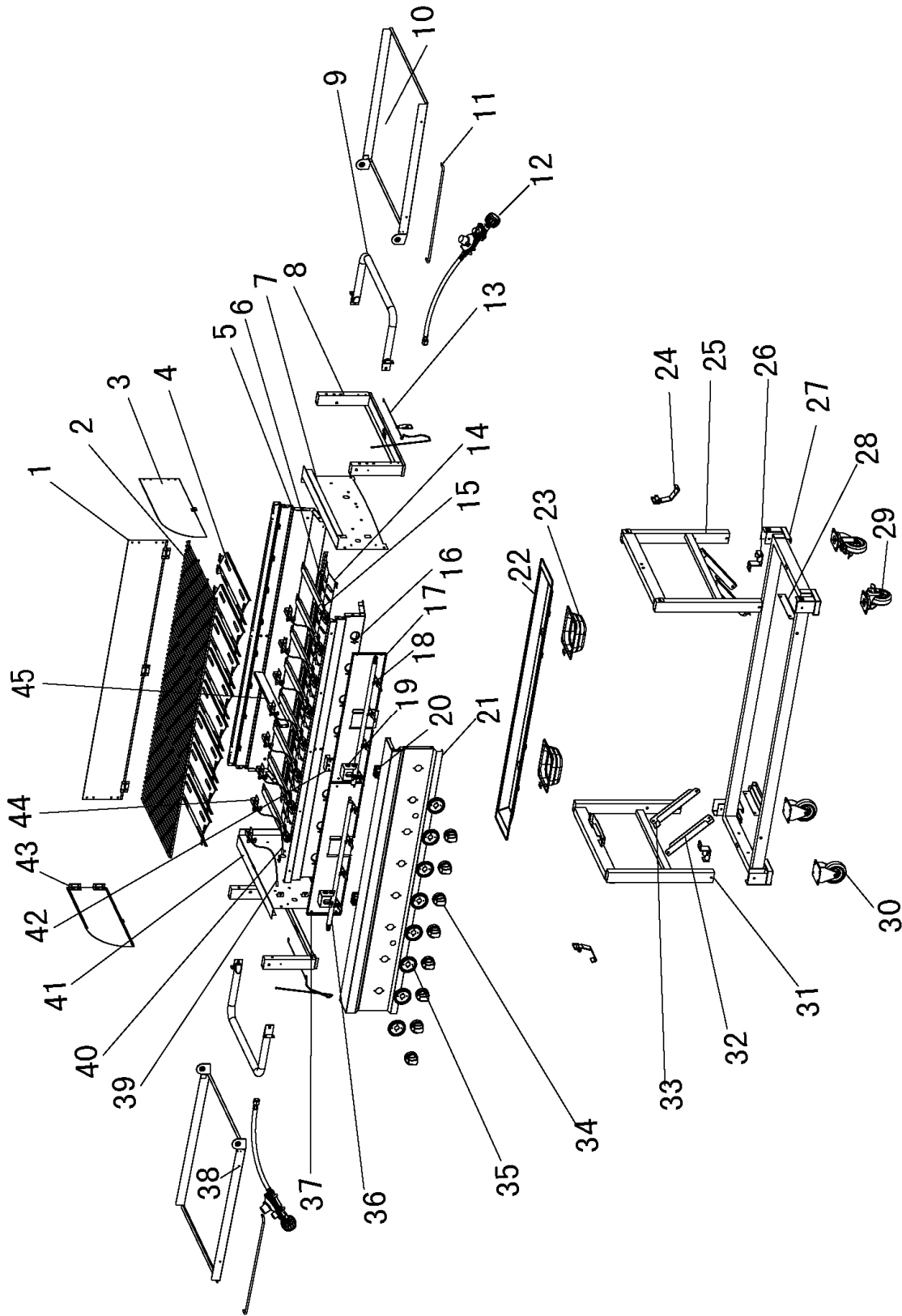





Product Diagram

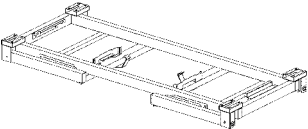
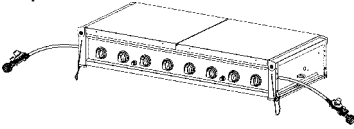

Parts List

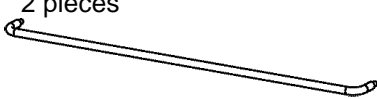
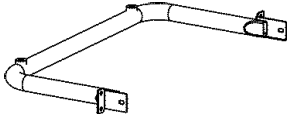
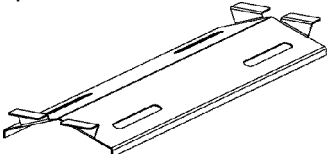
	Part Number	Part Description	Qty
1	DQ08A-01-00	Wind shield back panel	1
2	DQ08A-03-46	Cooking Grid	3
3	DQ08A-01-02	Wind Shield, right panel	1
4	DQ08A-03-44	Flame Tamer	8
5	DQ08A-03-04	Grill Body, back panel	1
6	DQ08A-03-41	Lead Fire Slot Assy	7
7	DQ08A-03-02	Grill Body, right panel	1
8	DQ08A-03-47	Body Post Assy	2
9	DQ08A-02-01	Side handle	2
10	DQ08A-02-11	Right side shelf	1
11	DQ08A-02-09	Towel rack	2
12	DQ08A-03-26	Regulator	2
13	DQ08A-03-24	Igniter rod	2
14	DQ08A-03-34	Baffle Board Assy	2
15	DQ08A-03-37	Burner Assy	8
16	DQ08A-03-03	Grill body front panel	1
17	DQ08A-03-09	Right Valve Install Plank Assy	1
18	DQ08A-03-17	Right Valve Windpipe Assy	1
19	DQ08A-03-30	Igniter Cover	2
20	DQ08A-03-29	Igniter	2
21	DQ08A-03-15	Control Panel	1
22	DQ08A-04-10	Grease receptacle	1
23	DQ08A-04-14	Grease tray	2
24	DQ08A-04-17/18	Gas Tank Hook	2
25	DQ08A-04-09	Right Frame Leg Assy	1
26	DQ08A-05-07	Gas Tank holder	2
27	DQ08A-05-01	Cart Bottom Frame Assy	1
28	DQ08A-05-08	Grease Receptacle Bottom Holder	2
29	DQ08A-05-10	Universal Caster	2
30	DQ08A-05-09	Directional Caster	2
31	DQ08A-04-02	Left Frame Leg Assy	1
32	DQ08A-04-19	Left Cart frame bracket	2
33	DQ08A-04-20	Right Cart frame bracket	2
34	DQ08A-04-27	Knob	8
35	DQ08A-03-28	Knob Holder	8
36	DQ08A-03-16	Left Valve Windpipe Assy	1
37	DQ08A-03-06	Left Valve Install Plank Assy	1
38	DQ08A-02-05	Left Side shelf	1
39	DQ08A-03-31	Igniter Wire 1	4
40	DQ08A-03-32	Igniter Wire 2	4
41	DQ08A-03-01	Left Side Plate, Body	1
42	DQ08A-03-11	Support, Valve Install Plank	1
43	DQ08A-01-01	Windshield Left Panel	1
44	DQ08A-03-33	Gas collector box with Electrode	8
45	DQ08A-03-05	Strengthen Plank, Body	1

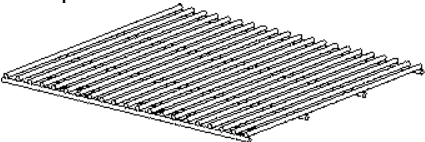
Component List

<p>A: Grill Cart 1 piece</p> 	<p>B: Grill Body 1 piece</p> 	<p>C: Directional Caster 2 pieces</p> 
<p>D: Universal Caster 2 pieces</p> 	<p>E: Grease Receptacle 1 piece</p> 	<p>F: Towel Rack 2 pieces</p> 
<p>G: Side Handle 2 pieces</p> 	<p>H: Flame Tamer 8 pieces</p> 	<p>J: Grease Tray 2 pieces</p> 
<p>K: Cooking Grid 3 pieces</p> 	<p>L: Gas Tank Holder 2 pieces</p> 	

Assembly Instructions

1. **Install Casters.**
 - With an assistant or other person, lift Cart A out of shipping carton and place it on the cardboard work surface.
 - Install directional Casters C to each Left Cart Legs bucket, and universal Caster D to Right Cart Legs bracket by using bolt #1.

Warning: Make sure that all the caster had been tightened before un-fold the legs of cart.

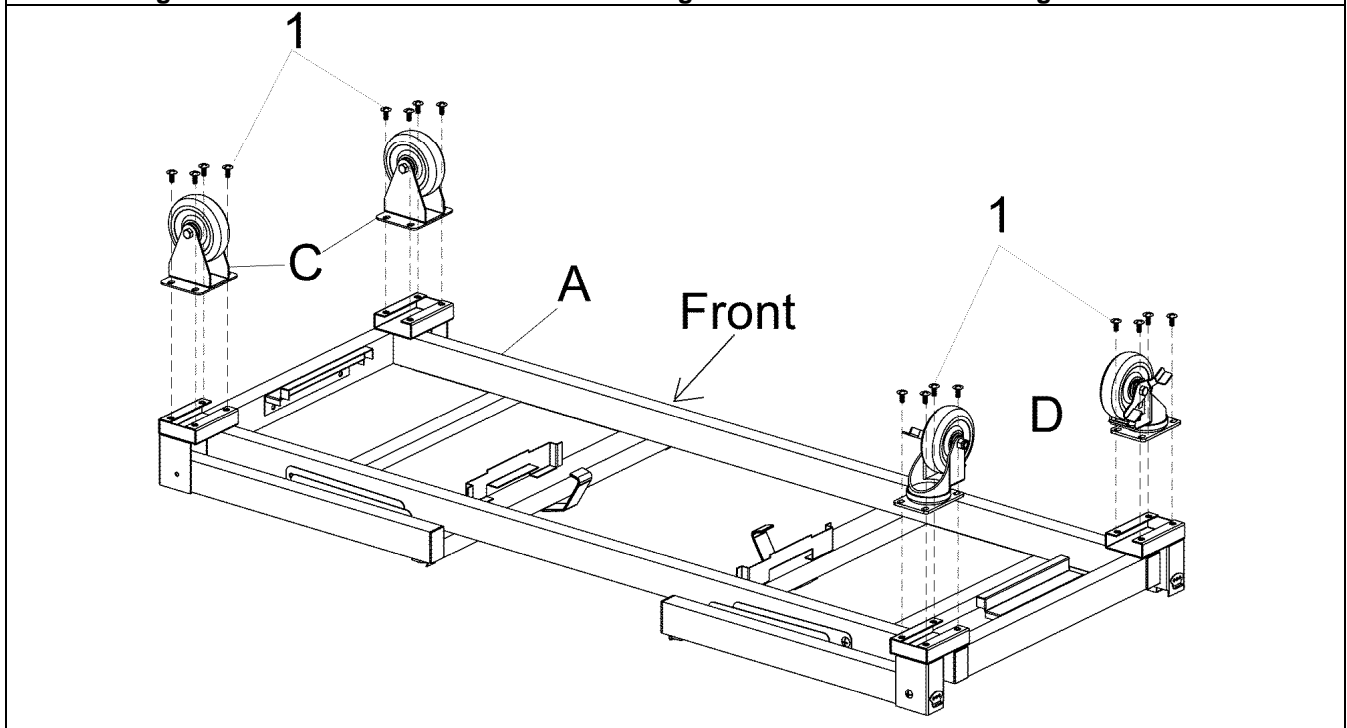

2. Assemble Cart

- With an assistant or some person again, turn the cart up-side-down.
 - Unfold the Cart Legs and align the Cart Frame Bracket to the legs. Then tighten the bracket with bolt #3.
- CAUTION: Do not stand, lean or apply pressure to the Cart Frame Bracket once assembly.

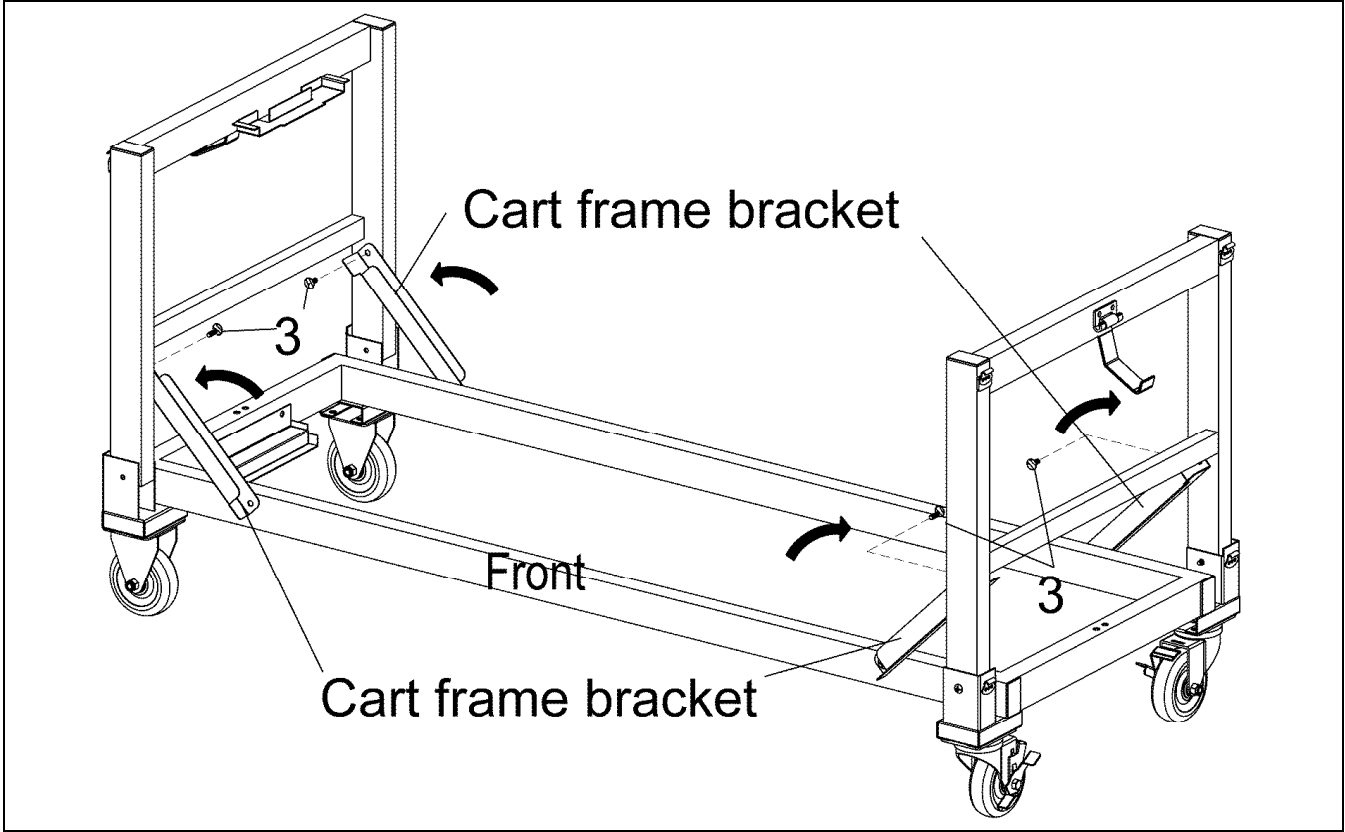

3. Install bottom gas tank holder

Install gas tank Holder L to the left and right lower bar of cart frame and secure with bolt #2.

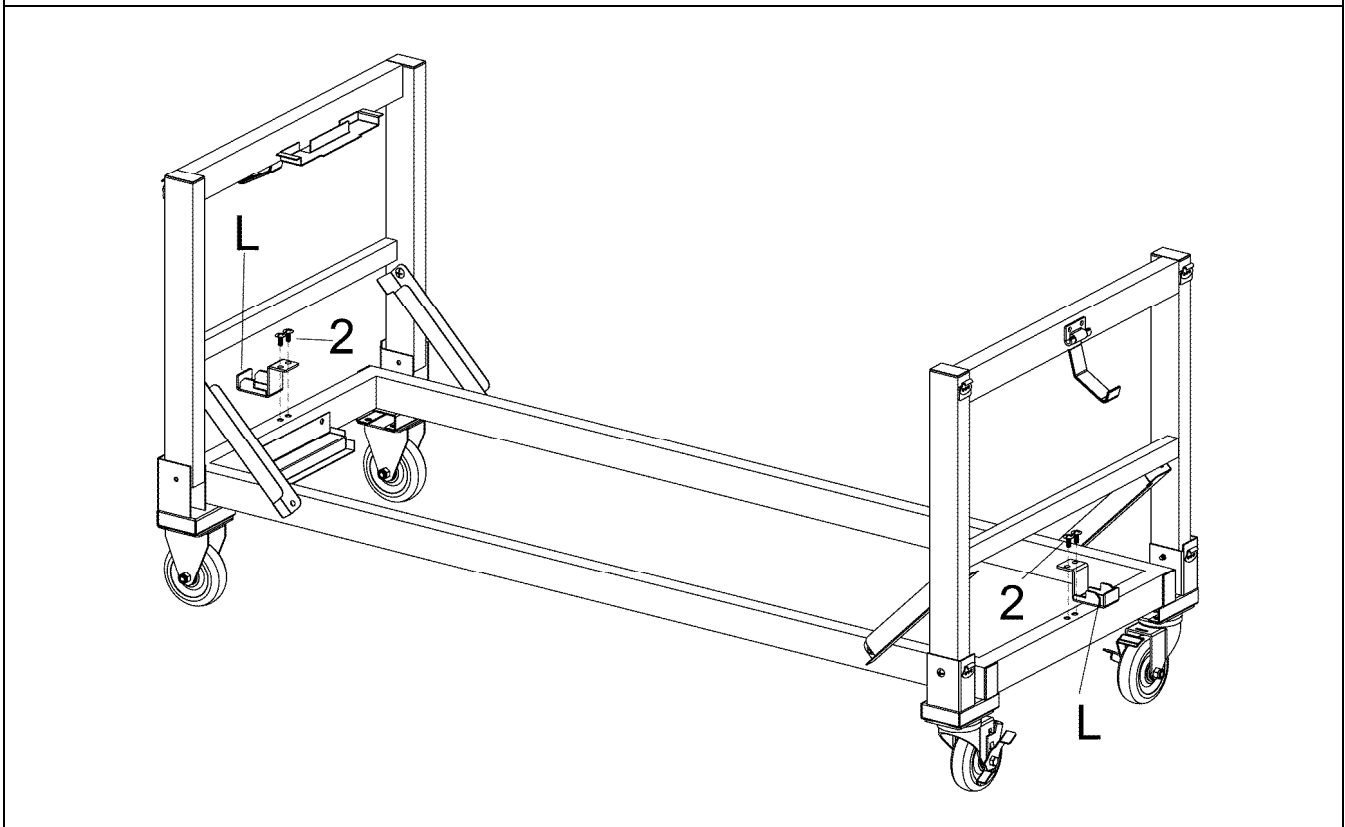

4. Assemble and Install Grease Receptacle and Grease Tray

- Position Grease Receptacles E to the Holders on the left and right upper bar of cart.
- Slide the Grease Tray J to the slots underneath Grease Receptacle E. The Grease Tray is required to be present and centered for safety.

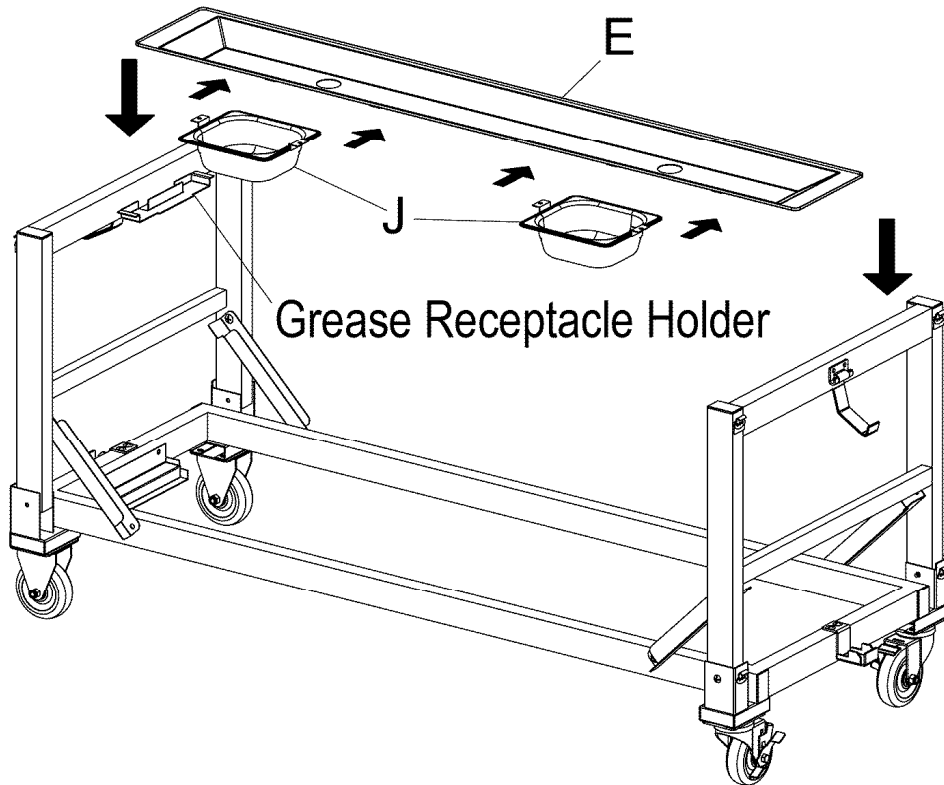

5. Install Handles

Align the handles to the left and right sides of grill body. Then tighten the handles with bolt #2 as per below picture. Also use Bolt #2 and washer #5 to hold the handle as per diagram below as well.

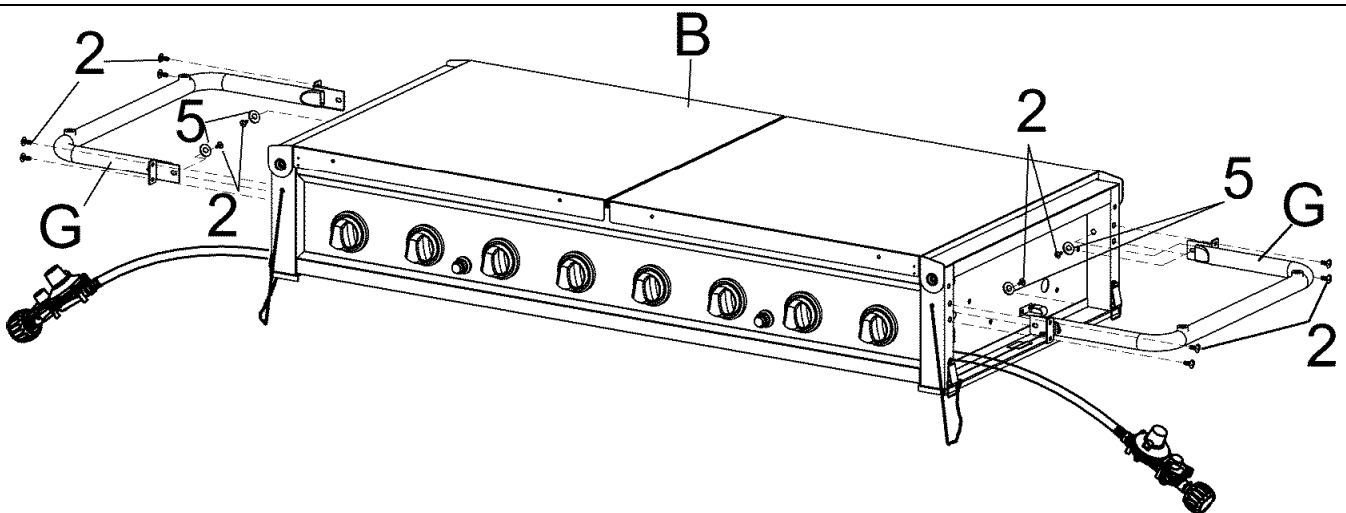

6. Install Grill Body

- With an assistant or other person, lift and position Grill Bowl body to the Cart.
 - Make sure that bottom four corners of grill body must be sitting on the SEAT on each leg.
 - Then lock each leg by closing the latch of each buckle on legs and grill body.
- Warning: Always keep the latches locked.

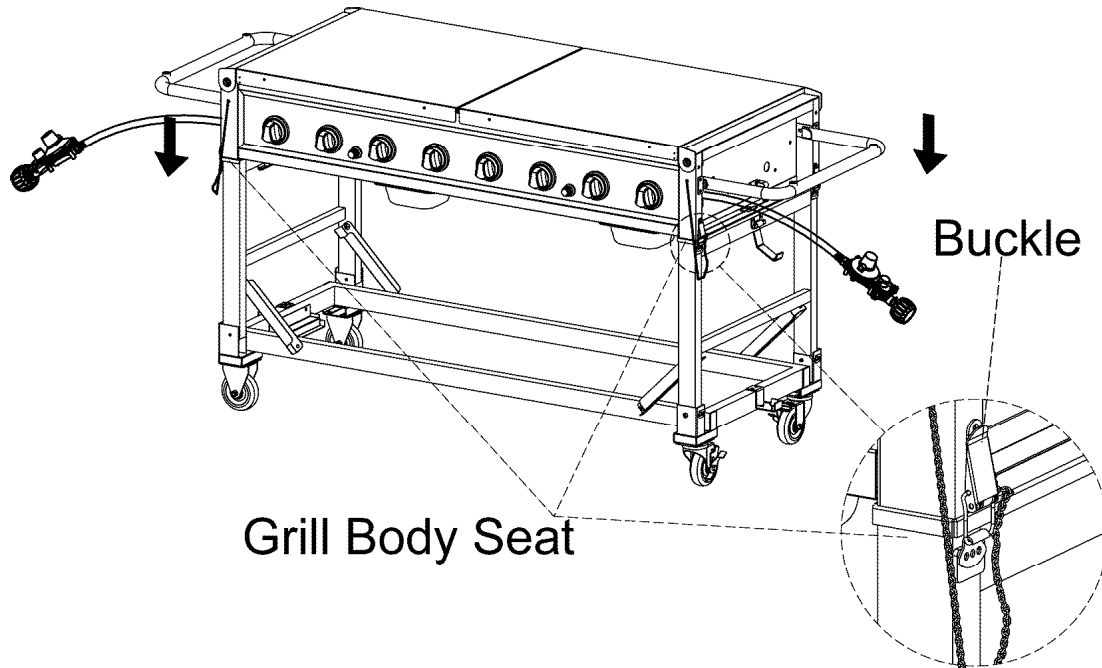

7. Install Windshield

1. Open the side shelf and let them rest on side handles.
2. Open the wind shield.
3. Unfold the left and right panel of wind shield and insert the small flag on bottom edge of panel to the slot on grill body frame.

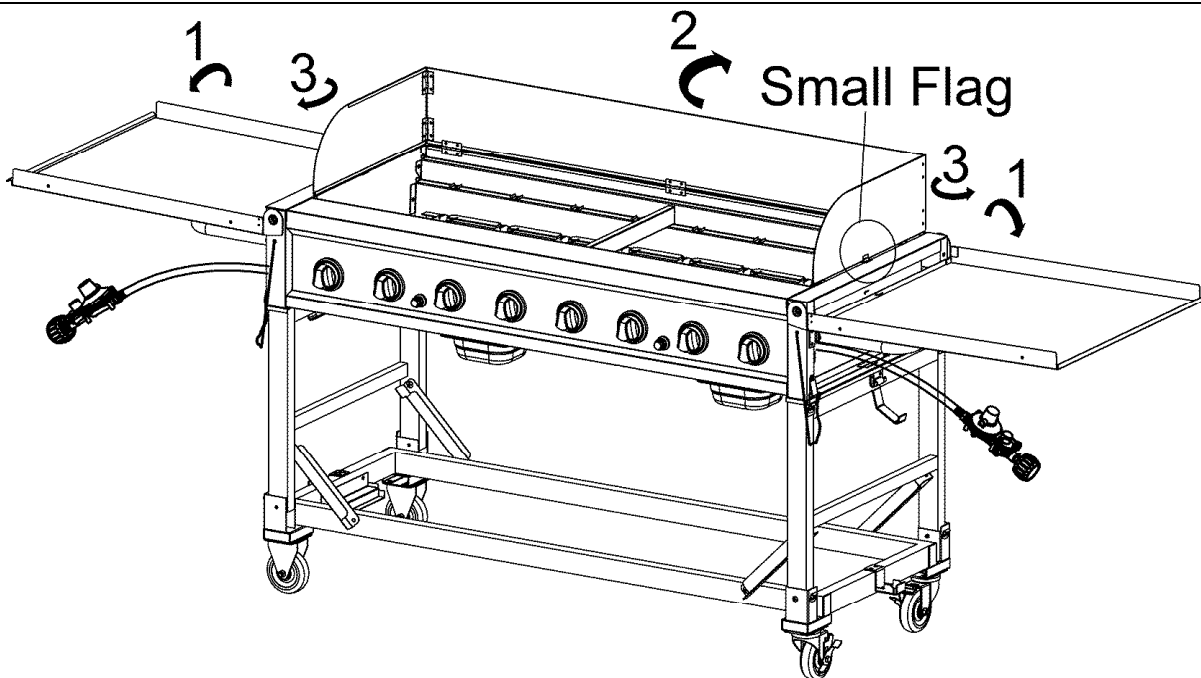

8. Install Heat Plates

- Place the Flame Tamer on the grill and make sure that each tamer will be placed over the burner.

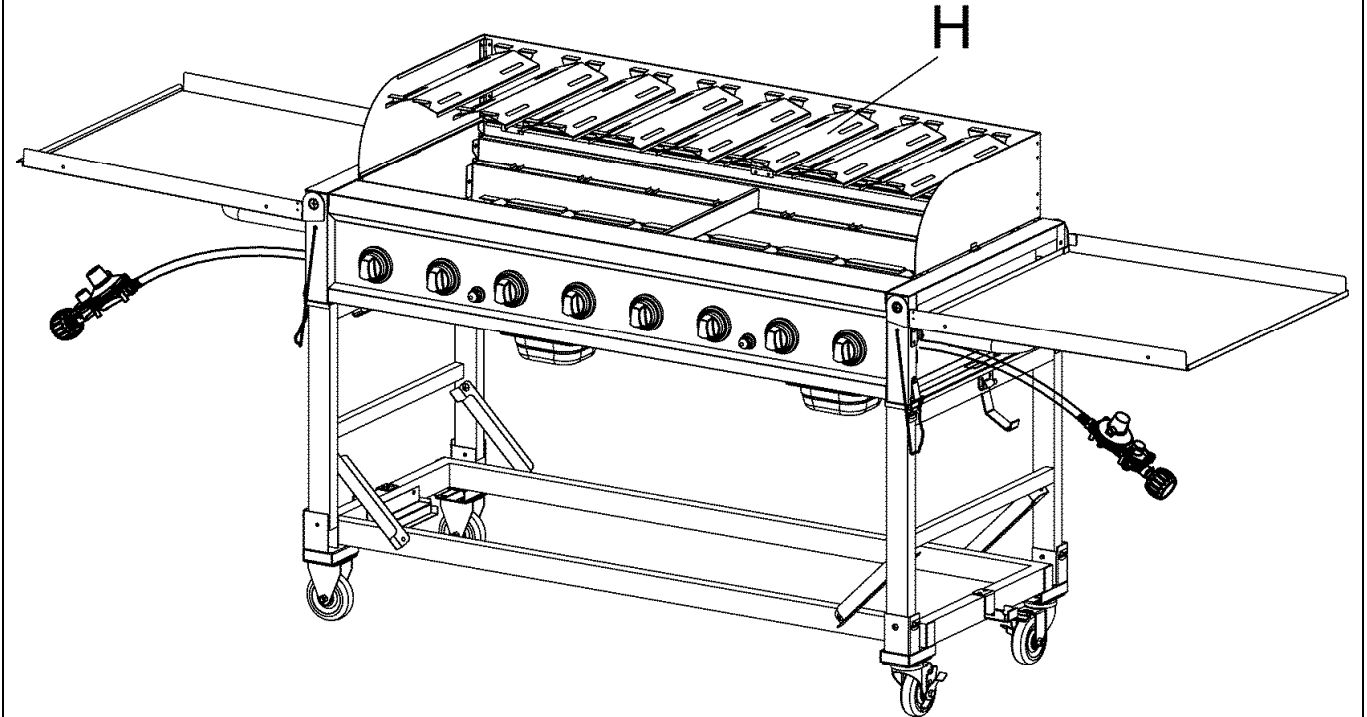

9. Install Cooking Grid

- Place the cooking grid inside the grill body.

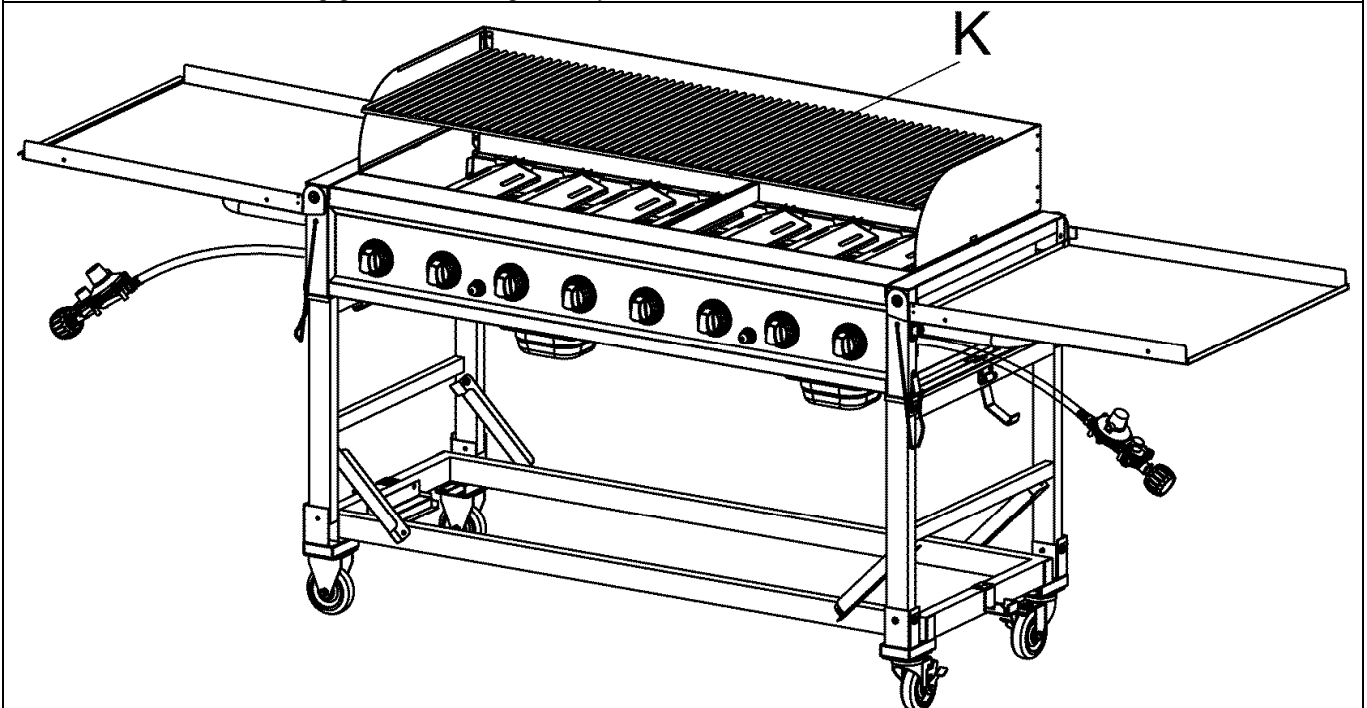

10. Install Hanger

- Install towel rack to left and right side shelf and secure with bolt #4.

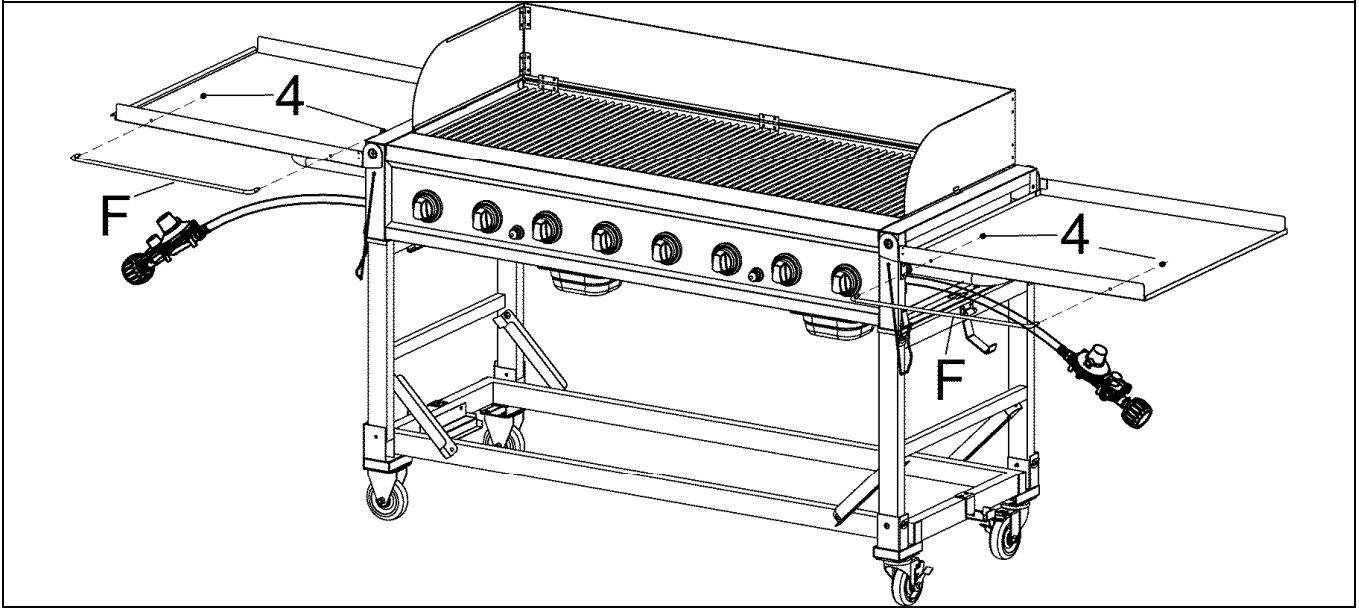

11. Install Ignitor Batteries

- Unscrew Ignitor Cap from Control Panel
- Place an AA battery into the igniter body with +VE outward and -VE inward.
- Position the Cap and Spring over the +VE end and tightly screw it onto the control panel.
- Repeat the same process for the igniter on the other side.

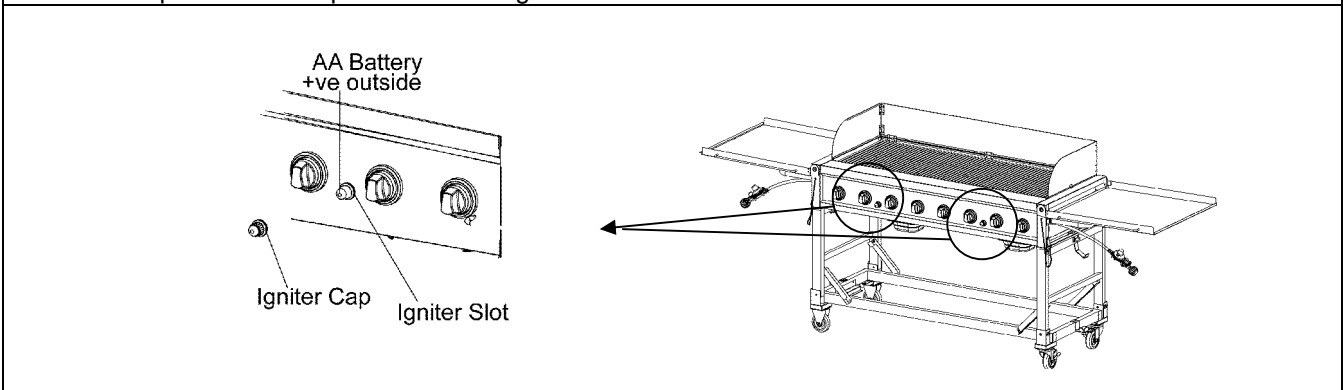

Electrode Check

With the assistance of another person, perform this Electrode Check before proceeding

- This test will ensure that the Spark Electrode Tips are properly positioned so your grill lights easily and properly.

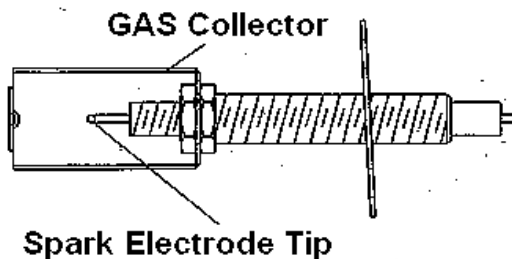

- Be sure all Control Knobs are set to “OFF” and open the Grill Lids
- Have your assistant stand behind to the right of the grill and look toward the front of the grill bowl. Never put your face inside the Grill Head.
- Press the Igniter Cap, You should hear a “clicking” sound. Your assistant should see a blue spark within each Gas Collector Box. If a spark is present Electrode Tips are properly positioned..
- If no spark is seen, the Spark Gap needs to be adjusted as follows:
 - If no spark is seen, the Spark Gap Electrode Tip and Receiver is more than 3/16” use long nose pliers to gently squeeze the Gas Collector Box to narrow gap.
 - Recheck the Electrode again, if no “clicking” sound is heard:
 - ◆ AA Battery is installed backwards.
 - ◆ Electric wires may be loose. Remove the AA Battery and inspect the Ignitor Junction Box found behind the Control Panel and reconnect any loose wires.

Final Grill Assembly Step

When you have finished assembling your grill be sure that all screws and latch are tightened for safe operation of your grill.

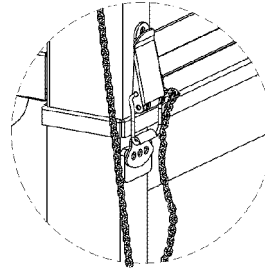

	WARNING	
Failure to read and follow the Use and Care Instructions could result in a fire or explosion that could cause serious bodily injury, death or property damage.		

Transporting or Storing your grill:

1. Lock grill Casters.
2. Remove LP Gas tank, Grease Receptacle and Grease Tray from your grill. Place Grease Receptacle on Lower Grease Tray Bracket. See Fig.1.
3. Loosen 4 Latches on Grill Bowl and Cart. With an assistant. Lift and position Grill Bowl on a cardboard surface.
4. Loose the bolt #3 and let the 4 cart frame bracket rest on the cart. In order to avoid loosing the 4 pieces bolt, make sure that they are screwed on the folding legs again . Then fold the Cart Legs onto Cart Frame. See Fig.1.
5. With an assistant, lift and position Grill Bowl onto the folded Cart. See Fig.2.
6. Be sure grill is secured tightly and covered when being transported.

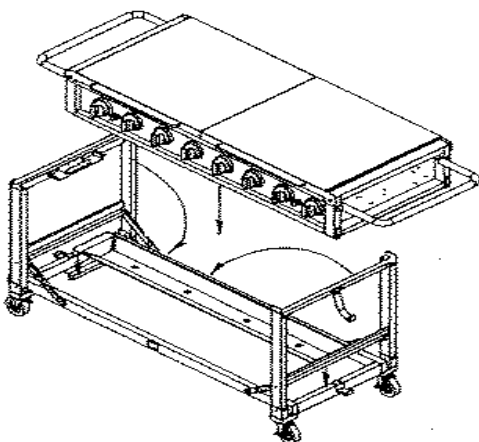

Fig.1

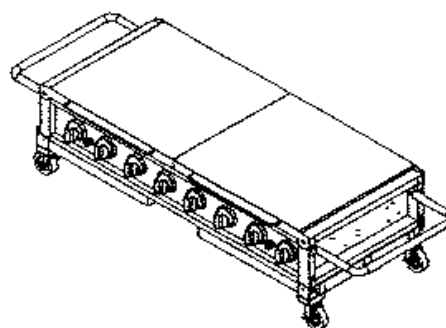
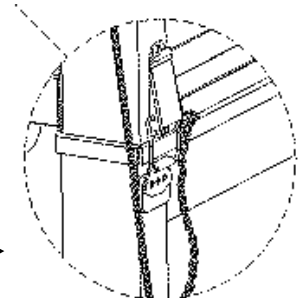

Fig.2



Use and Care Instructions

Correct LP Gas Tank Use

- LP Gas grill models are designed for use with two standard 20 lb. Liquid Propane Gas (LP Gas) tanks, not included with grill. **Never** connect your gas grill to an LP Gas tank that exceeds this capacity. A tank of approximately 12 inches in diameter by 18-1/2 inches high is the maximum size LP Gas tank to use. **You must use an “OPD” gas tank which offers a listed Overfill Prevention Device.** This safety feature prevents tank from being overfilled which can cause malfunction of LP gas tank, regulator and/ or grill.
- The LP Gas tank must be constructed and marked in accordance with the Specifications for LP-Gas Cylinders of the U.S. Department of Transportation (D.O.T.) or the National Standard of Canada, CAN/ CSA-B339, Cylinders, Spheres and Tubes for Transportation of Dangerous Goods; and Commission, as applicable.
- The LP Gas tank must have a shutoff valve, terminating in an LP Gas supply tank valve outlet, that is compatible with a Type 1 tank connection device. The LP Gas tank must also have a safety relief device that has a direct connection with the vapor space of the tank.
- The tank supply system must be arranged for vapor withdrawal.
- The LP Gas tank used must have a collar to protect the tank valve.
- When two cylinders are provided, if the gas supply system is set up so that the appliance only operates on one cylinder at a time, the cylinder not in use, whether filled with fuel or empty, shall be stored and transported on the exterior of the appliance.
- Never connect an unregulated LP gas tank to your gas grill. The gas regulator assembly supplied with your gas grill is adjusted to have an outlet pressure of 11” water column (W.C.) for connection to an LP gas tank. Only use the regulator and hose assembly supplied with your gas grill. Replacement regulators and hose assemblies must be those specified by the Manufacture.
- Have your LP Gas dealer check the release valve after every filling to ensure it remains free of defects.
- Always keep LP Gas tank in upright position.
- Do not subject the LP Gas tank to excessive heat such as a closed car, trunk, or in direct sunlight.
- The LP-gas cylinders are not to be stored in any compartments on the appliance that are not intended for cylinder storage and that such unauthorized storage could lead to an explosion, fire, or personal injury.
- Never store an LP Gas tank indoors. If you store your gas grill in the garage **always** disconnect the LP Gas tank first and store it safety outside.
- LP Gas tanks must be store outdoors in a well-ventilated area and out of the reach of children.
- Disconnected LP Gas tanks must not be stored in a building, garage or any other enclosed area.
- If the appliance is not in use, the gas must be turned off at the supply cylinder.
- The cylinder is fitted with a Type I Cylinder Connection Device. A protective dust cap must be installed on the valve outlet.
- The regulator and hose assembly can be seen after opening the doors (if applicable) and must be inspected before each use of the grill. If there is excessive abrasion or wear or if the hose is cut, it must be replaced prior to using the grill again.
- **Never** light your gas grill with the lid closed or before checking to unsure the burner tubes are fully seated over the gas valve orifices.
- **Never** allow children to operate your grill. Do not allow children or pets to play near your grill.
- **Use** of alcohol, prescription or non-prescription drugs cam impair your ability to properly assemble and safely operate your grill.
- Keep your grill covered during freezing rain or snow. Sleet and snow can block the regulator vent hole resulting in improper and potentially dangerous regulator pressure.
- Use your grill on a level, stable surface in an area clear of combustible materials.
- Do not leave grill unattended when is use..
- Allow the grill to cool before moving or storing. Do not use your grill as a heater
- This grill is not intended to be installed in or on recreational vehicles and/ or boats.



WARNING



- A. Do not store a spare LP-Gas tank under or near this appliance.
- B. Never fill the tank beyond 80 percent full; and
- C. If the information in “(a)” and “(b)” is not followed exactly, a fire causing death or serious injury may occur.



WARNING



- **Use your grill at least 3 feet away from any wall or surface.** Use your grill at least **3 feet away** from combustible objects that can melt or catch fire such as vinyl or wood siding, fences and overhangs or sources of ignition including pilot lights on water heaters and live electrical appliance.
- Outdoor cooking gas appliance shall not be used under overhead combustible construction.
- The temperatures on the walls adjacent to back sides of the appliance and on the floor under the appliance, including those wall and floor surface extending beyond the profile of the appliance, shall not be more than 117°F (65°C) in excess of room temperature. The minimum environmental temperature for safe use of the appliance is 32°F (0°C)
- Keep the appliance area free and clear form combustibles.
- Never obstruct the flow of ventilation air around your gas grill housing.
- In windy conditions, always position the front of grill to face oncoming wind to reduce smoke and heat blowing in your face and prevent potential hazards to self and grill.

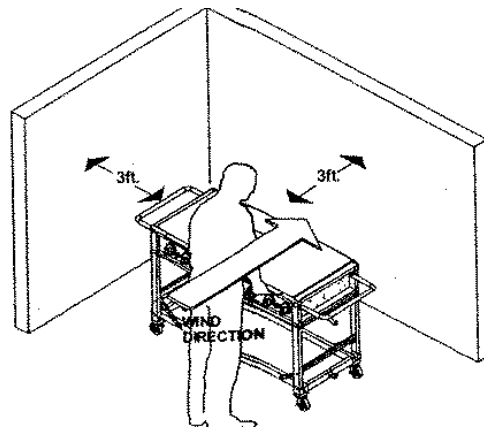

Use and Care Instructions

Note about LP Gas Tank Exchange Programs

- Many retailers that sell grills offer you the option of replacing your empty LP Gas tank through an exchange service. Use only those reputable exchange companies that inspect, precision fill, test and certify their tanks. Exchange your tank only for an OPD safety feature-equipped tank as described in the LP Gas tank section of this manual.
- Always keep new and exchanged LP Gas tanks in an upright position during use, transit or storage.
- Leak test new and exchange LP Gas tanks **BEFORE** connecting one to your grill.

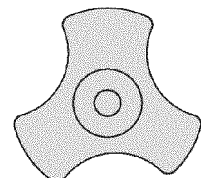



OPD Hand Wheel

How to leak Test your LP Gas tank

For your safety:

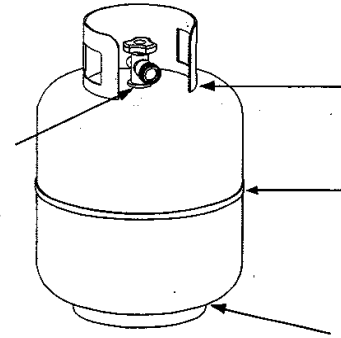
- All leak tests must be repeated each time your LP Gas tank is exchanged or refilled.
- When checking for gas leaks do not smoke.
- Do not use an open flame to check for gas leaks
- Your grill must be leak tested outdoors in a well-ventilated area, away from ignition sources such as gas fired or electrical appliances. During the leak test, keep your grill away from open flames or sparks.
- Do not use household cleaning agents. Damage to gas assembly components can result.
 - Use a clean paintbrush and a 50/50 mild soap and water solution.
 - Brush soapy solution onto LP Gas tank in the areas indicated by the arrows. See diagram.
 - If growing bubbles appear do not use or move the LP Gas tank, call an LP Gas Supplier or your Fire Department.



	<h1>WARNING</h1>	
<p>If growing bubbles appear do not use or move the LP Gas tank. Contact an LP Gas Supplier or your fire department.</p>		

	<h1>WARNING</h1>	
<p>Before using this gas appliance read all instructions and perform all gas leak-check procedures even if the product was pre-assembled by the retailer or manufacturer.</p>		

LP Gas Model only:

Secure two 20lb LP Gas Tanks to Gas Grill

- Turn your LP Gas Tank Valves clockwise to the closed or OFF position.
- Hang your gas tanks on the top Tank Hooks. The ring foot of the gas tanks will rest on the Tank Holder.

Cylinders Installation Code

The handling, storage, and transportation of all sizes of gas cylinders must be in accordance with *ANSI/NFPA 58, Storage and Handling of liquid Petroleum Gases*, or the *CSA B149.1, Natural Gas and Propane Installation Code*.

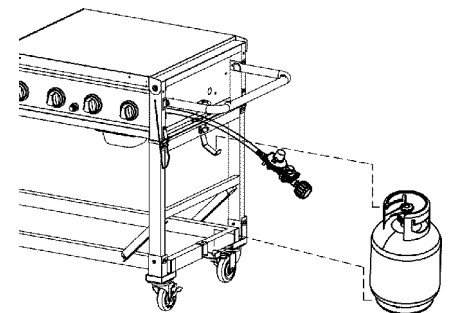

LP Gas Model only:

Connect regulator with Hose to your 20lb LP Gas Tanks

- Turn all Burner Valves to the OFF position.
- Inspect the valve connection port and regulator assembly for damage or debris. Remove any debris. Never use damaged or plugged equipment.

- Connect the regulator assembly to the tank valve and **HAND TIGHTEN** nut clockwise to a full stop. **DO NOT** use a wrench to tighten because it could damage the Quick Coupling Nut and result in a hazardous condition.
- Open the tank valve fully (counterclockwise) and use a soapy water solution to check all connections for leaks before attempting to light your grill. See **“Checking for LP Gas Leaks”**. If a leak is found, turn the tank valve off and do not use your grill until the leak is repaired.

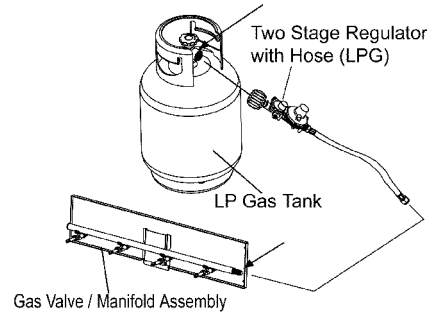

CAUTION: When the appliance is not in use the gas must be turned off at the tanks.

Check all connections for LP Gas Leaks

Never test for leaks with a flame. Prior to first use, at the beginning of each season, or every time your LP Gas tank is changed, you must check for gas leaks. Follow these three steps:

- Make a soap solution by mixing one part liquid detergent and one part water.
- Turn the grill Control Knobs to the full OFF position, then turn the gas ON at source.
- Apply the soap solution to all gas connections indicated by the arrows. See diagram. If bubbles appear in the soap solution the connections are not properly sealed. Check each fitting and tighten or repair as necessary.
- If it is evident there is excessive abrasion or wear, or the hose is cut, it must be replaced prior the appliance being put into operation. The replacement hose assembly shall be that specified by the manufacturer.

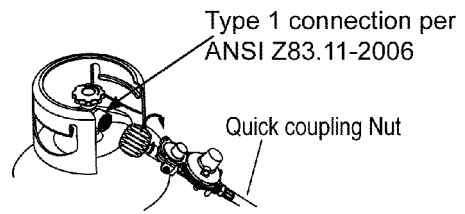

	WARNING	
<p>If you have a gas leak that cannot be repaired by tightening, turn off the gas at the source, disconnect fuel line from your grill and call your gas supplier for repair assistance.</p> <p>Never disconnect the gas regulator or any gas fitting while your grill is lit. A lit grill can ignite leaking gas and cause a fire or explosion which could result in property damage, personal injury or death.</p>		

Disconnecting a Liquid Propane Gas (LPG) Tank From Your Grill

- Make sure the Burner Valves and LP Gas tank valve are off. (Turn clockwise to close.)
- Detach the hose and regulator assembly from the LP Gas tank valve by turning the Quick Coupling Nut counterclockwise.

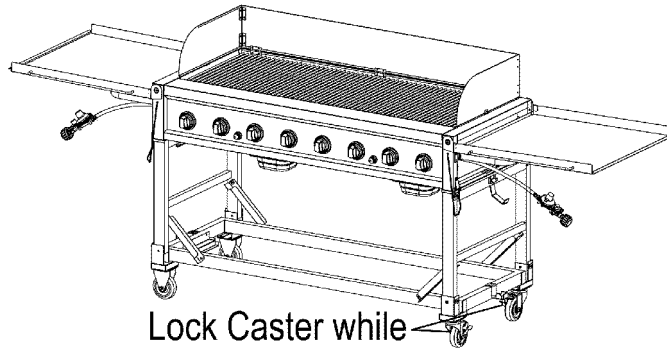

Lock Caster while
your grill is in use



CAUTION



Always open both left and right Lids as shown before lighting your grill.
Lock the wheels to prevent movement while the appliance is in use
Wind shield must be properly installed while the appliance is in use

Grill Lighting Instructions

NOTE: This gas grill is designed to be used with two 20lb LP Gas tanks (not included) for 8 burner operation. A tank placed on the right will operate the four right-side burners. A tank placed on the left will operate the four left-side burners.

Burner Control Knobs on Control Panel

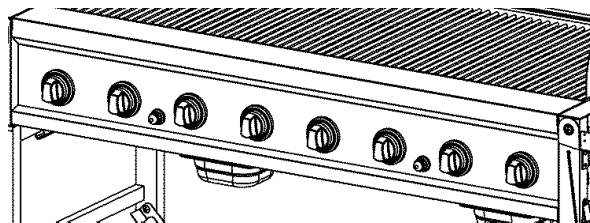

1. Before each use, check all hoses for cracks, nicks, cuts, burns or abrasions. If a hose is damaged in any way, do not use your grill before replacing the hose with an authorized part from the Parts List. Also make sure all gas supply connections are securely tightened.
2. For optimum performance this grill should be used only when outdoor temperatures are 60 degrees or above.
3. Familiarize yourself with the safety and Use and Care instructions in this manual. Do not smoke while lighting grill or checking gas supply connections.
4. Be sure each LP Gas tank is filled and lock Casters to prevent movement during grill operation.
5. Open the left and right Lids before lighting the grill.
6. Check that the end of each Burner Tube is properly located over each Valve Orifice.

7. Set all Control Knobs to OFF and open the right-side tank valve SLOWLY 1/4 of a turn.

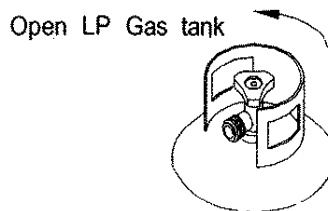
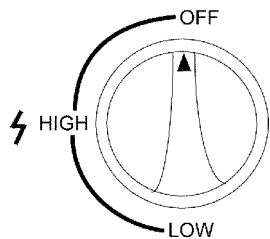

8. To light the four right-side burners, push and turn the forth Control Knob from the right to HIGH. This is considered the middle right Control Knob.

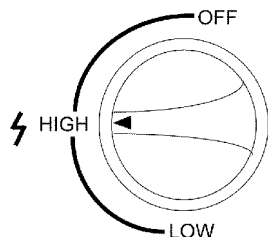

9. Immediately press the right-side Electric Igniter for 3-4 seconds to light the Burner.

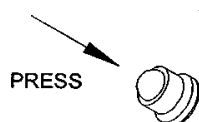

10. If ignition does not occur in 5 seconds, turn the burner Control Knob(s) and gas source OFF and conduct a leak test of ALL gas connections and gas sources as explained in the Use and Care section of this manual. If no leaks are detected, wait 5 minutes for any gas to clear and repeat the lighting procedure.
11. After one Burner is lit, turn the tank valve SLOWLY one more 1/4 of a turn for 1/2 of one complete turn.

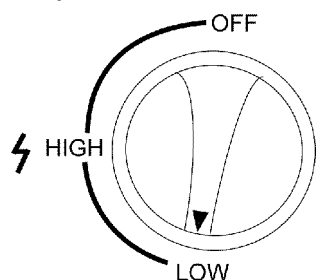

12. Once one Burner is lit, the adjacent Burner can be lit by turning its Control Knob to HIGH.
13. To light the four left-side burners repeat step 7 and 8 then press the left-side Electric Igniter.

	<h1>DANGER</h1>	
<p>The gas pressure regulator provided with this appliance must be used. This regulator is set for an outlet pressure of 11 iwc.</p>		

WARNING

Failure to replace a faulty hose, secure gas supply connections or to open the Lids before proceeding to the Lighting Procedures could result in a fire or explosion that could cause serious bodily injury, death, or property damage.

Manually Lighting Your Grill By Paper Match

To light your gas grill by match, insert a match into the Lighting Stick and follow steps 1 through 7 of the Grill Lighting Instructions. Then, light the match and place Lighting Stick through the Cooking Grid on the grill as shown below. Turn the Control Knob nearest the open tank to the HIGH setting to release gas. The Burner should light immediately.

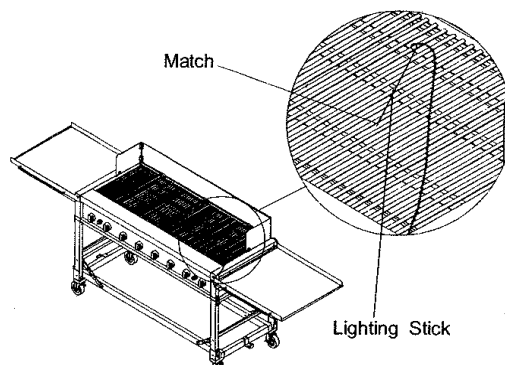

WARNING

Never lean over the grill cooking area while lighting your gas grill. Keep your face and body a safe distance (at least 18 inches) from the Lighting Hole or Burners when lighting your grill by match.

Use and Care Instructions

To purge air from your gas line and/or reset the regulator excess gas flow device:

- Turn Control Knobs to the OFF position.
- Turn off the gas at the tank valve.
- Disconnect regulator from LP Gas tank.
- Let unit stand 5 minutes to allow air to purge.
- Reconnect regulator to the LP gas tank.
- Open the Grill Lids.
- Turn tank valve on SLOWLY 1/4 of a turn.
- Push and turn the middle Control Knob farthest from open tank to HIGH.
- Press Electric Igniter for 3-4 seconds to light the burners.

WARNING

Should a FLASHBACK fire occur in or around the Burner Tubes, follow the instructions below. Failure to comply with these instructions could result in a fire or explosion that could cause serious bodily injury, death, or property damage.

- Shut off gas supply to the gas grill.
- Turn the Control Knobs to OFF position.
- Open the Grill Lids.
- Put out any flame with a Class B fire extinguisher.
- Once the grill has cooled down, clean the Burner Tubes and Burner according to the cleaning instructions in this Operator's Manual.



WARNING

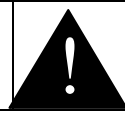

Failure to comply with these instructions could result in a fire or explosion that could cause serious bodily injury, death or property damage.

- Keep grill area clear and free from combustible materials, gasoline and other flammable vapors and liquids.
- Do not obstruct the flow of air for combustion and ventilation.
- Keep the ventilation openings of the tank enclosure cabinet free and clear of debris.
- Visually check burner flames occasionally to ensure proper flame pattern as shown below.

Cleaning of Maintenance

Proper care and maintenance will keep your grill in top operating condition and prolong its life. Follow these cleaning procedures on a timely basis and your grill will stay clean and operate with minimum effort.

CAUTION: Be sure your grill is OFF and cool before cleaning.

Cleaning The Cooking Grids

- Before initial use, and periodically, wash your Cooking Grids in a mild soap and warm water solution. You can use a wash cloth or vegetable brush to clean your Cooking Grids.

Cleaning the Heat Plate

- Periodically you should wash the Heat Plates in a soap and warm water solution. Use a vegetable brush to remove stubborn burnt-on cooking residue. Dry the Heat Plates thoroughly before you reinstall them into the cooking bowl.

Cleaning the Grease Tray and Receptacle

- To reduce the chance of fire, the Grease Draining Tray and Grease Receptacle (some models) should be visually inspected before each grill use. Remove any grease and wash Grease Tray and Receptacle with a mild soap and warm water solution.

Cleaning the Inside of the Grill Lid

- Grease can have a tendency to build up on the inside of the Grease Lid and could drip onto deck or patio when the lid is opened. Visually inspect the inside of the Grill Lid before each grill use. Remove any grease and wash with a mild soap and warm water solution.

Routine Cleaning of The Grill Interior

- Burning-off excess food after every cookout will keep it ready for instant use. However, at least every 3 months you must give the entire grill a thorough cleaning to minimize your risk of grease fire and keep the grill in top shape. Follow these steps:
 1. Turn all Burner Valves to the full OFF position.
 2. Turn the LP gas tank valve to the full OFF position.
 3. Disconnect the regulator from the gas tank. Inspect the hose with regulator assembly for cracking, cuts or any other damage, and replace as necessary. Refer to the Parts List in this Operator's Manual.
 4. Remove and clean the Heat Plates, Cooking Grids and Grill Burners.
 5. Cover each Gas Valve Orifice with aluminum foil.
 6. Brush the inside and bottom of the grill with a fiber pad or nylon brush and wash with a mild soap and warm water solution. Rinse thoroughly and let dry.
 7. Remove aluminum foil from Orifices and check each Orifice for obstruction.

8. Check each Spark Electrode, adjusting as needed. The space between the Spark Electrode Tip and Spark Receiver should be approximately 3/16".
9. Replace the Burners and adjust the Gas Collector Box. The edge of the collector box should be overlapping the Burner Port.
10. Replace Saver Plates™ and Cooking Grids.
11. Reconnect the gas source and observe the Burner flame for correct operation.

Cleaning Exterior Painted Surfaces:

- Before initial use, and periodically thereafter, we suggest you wash your grill using a mild soap and warm water solution. You can use a wash cloth or sponge for this process. Do not use a stiff wire or brass brush. These will scratch stainless steel and chip painted surfaces (varies by model) during the cleaning process.

Cleaning Exterior Stainless Steel Surfaces:

- Routine care and maintenance is required to preserve the appearance and corrosion resistance of stainless steel. The fact is stainless steel can corrode, rust and discolor under certain conditions. Rust is caused when regular steel particles in the atmosphere become attached to the stainless steel surface. Steel particles can also become attached to your grill if you use steel wool or stiff wire brushes to clean the grill instead of non-abrasive cloth, sponge or nylon cleaning tools. In coastal areas rust pits can develop on stainless surfaces that cannot be fully removed. Bleach and other chlorine based solutions used for household and pool cleaning can also cause corrosion to stainless steel. Weathering, extreme heat, smoke from cooking and machine oils used in the manufacturing process of stainless steel can cause stainless steel to turn tan in color. Although there are many factors which can affect the surface appearance of stainless steel, they do not affect the integrity of the steel or the performance of the grill.
- To help maintain the finish of stainless steel follow these cleaning procedures for the best results:
 1. After every use (after your grill has cooled down), wipe stainless surfaces with a soft, soapy cloth or sponge then rinse with water. Be sure to remove all food particles, sauces or marinades from stainless steel because these can be highly acidic and damaging to stainless surface.
 2. Never use abrasive cleaners, scrubbers or stiff wire brushes of any type on your grill.
 3. Use a heat resistant Stainless Steel Cleaner and rub or wipe in the direction of the stainless steel grain or polish lines NOT against the grain.

Cleaning The Burner Tubes and Burner Ports

To reduce the chance of **FLASHBACK FIRE** you must clean the Burner Tubes as follows at least once a month in summer and fall or whenever spiders are active in your area, and if your grill has not been used for an extended period on time.

1. Turn all Burner Valves to the full OFF position.
2. Turn the LP Gas tank valve to the full OFF position.
3. Detach the LP Gas regulator assembly from your gas grill.
4. Remove the Cooking Grids, Flame Tamer and Grease Trays from your grill.
5. Remove the screw from the rear of each Burner using a Phillips Head Screwdriver.
6. Carefully lift each Burner up and away from the Gas Valve Orifice.
7. Check and clean burner/ venture tubes for insects and insect nests. A clogged tube can lead to a fire beneath the grill.
8. Refer to **Figure 1** and perform one of these three cleaning methods:

- METHOD 1: Bend a stiff wire or wire coat hanger into a small hook as shown and run the hook through the Burner Tube and inside the Burner several times to remove debris.

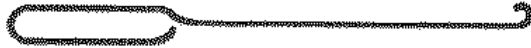

- METHOD 2: Use a bottle brush with a flexible handle and run the brush through the Burner Tube and inside the Burner several times to remove any debris.
- METHOD 3: Use an air hose to force air through each burner Tube. The forced air should pass debris or obstructions through the Burner and out the Ports.

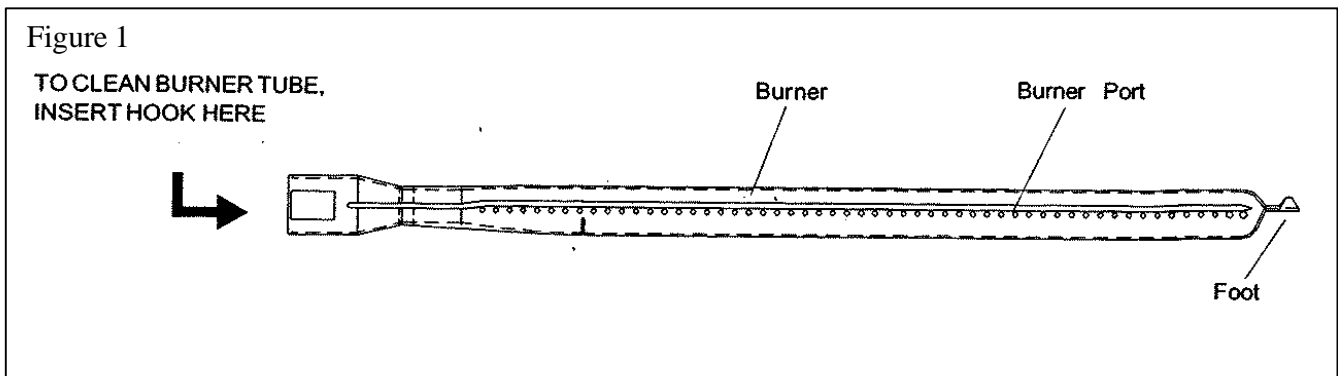

Regardless of which Burner cleaning procedure you use, we recommend you also complete the following steps to help prolong Burner life.

1. Use a fiber pad or nylon brush to clean the entire outer surface of each Burner until free of food residue and dirt.
2. Clean any clogged ports with a stiff wire, such as an open paper clip.
3. Inspect each Burner for damage (cracks or holes) and if such damage is found, order and install a new Burner. After installation, check to ensure that the Gas Valve Orifices are correctly placed inside the ends of the Burner Tubes. Also check the position of your Spark Electrode.



WARNING



For safe operation ensure the Gas Valve Assembly Orifice is inside the Burner Tube before using your grill. See figure. If the Orifice is not inside the Burner Tube, lighting the Burner may cause explosion and/ or fire resulting in serious bodily injury and/or property damage.

When an appliance is supplied on casters and is connected to the supply piping by means of a connector for movable appliances, the operator shall aware there is a restraint on the appliance and, if disconnection of the restraint is necessary, to reconnect this restraint after the appliance has been returned to its originally installed position.

Limited Warranty

Manufacturer warrants this Event Grill for replacement or repair of parts and/or workmanship for a period of 3 months. Paint is not warranted and may require touch-up. Items considered to be consumable such as batteries are not covered under these warranties.

These limited warranties are made exclusively to the original consumer presenting proof of purchase. Any returned goods must be shipped prepaid. These warranties do not cover normal wear and tear or damages resulting from abuse or misuse. This warranty excludes incidental or consequential cost due to damages or losses to persons or property of any nature.

NOTICE: Some states do not allow the exclusion or limitation of incidental or consequential damages or limitations on how long an implied warranty lasts, so the above limitations or exclusions may not apply to you.

This warranty gives you specific legal rights and you may also have other rights which may vary from state to state.

For further information or replacement parts, repair and maintenance, please contact manufacturer,

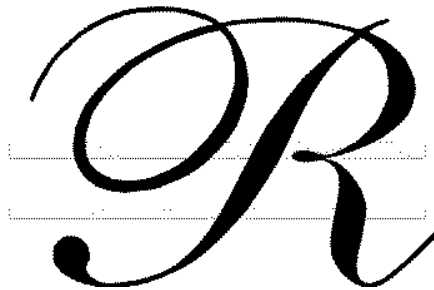

Toll Free # 1-888-837-1380
customerservice@rankam.com

Rankam Metal Products Manufactory Ltd.
1322 Rankin Drive,
Troy, MI 48083.