

This Owner's Manual is provided and hosted by [Appliance Factory Parts](http://ApplianceFactoryParts.com).

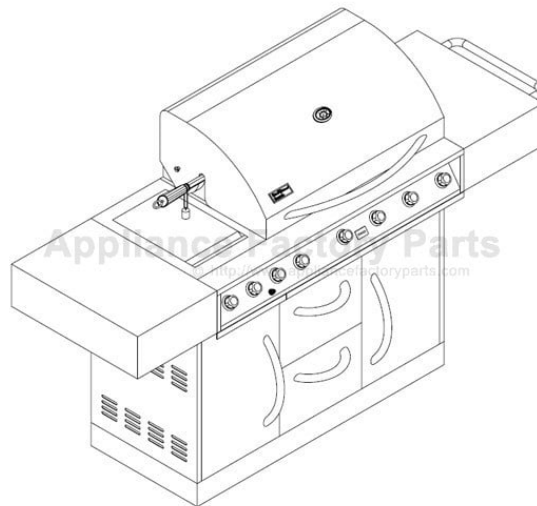

Nexgrill 730-0247 Owner's Manual

[Shop genuine replacement parts for Nexgrill 730-0247](#)



[Find Your Nexgrill Grill Parts - Select From 922 Models](#)

----- Manual continues below -----

**the Professional
Source**

**Stainless Steel Gas Grill
USE AND CARE GUIDE
MODEL NO.: 730-0247**

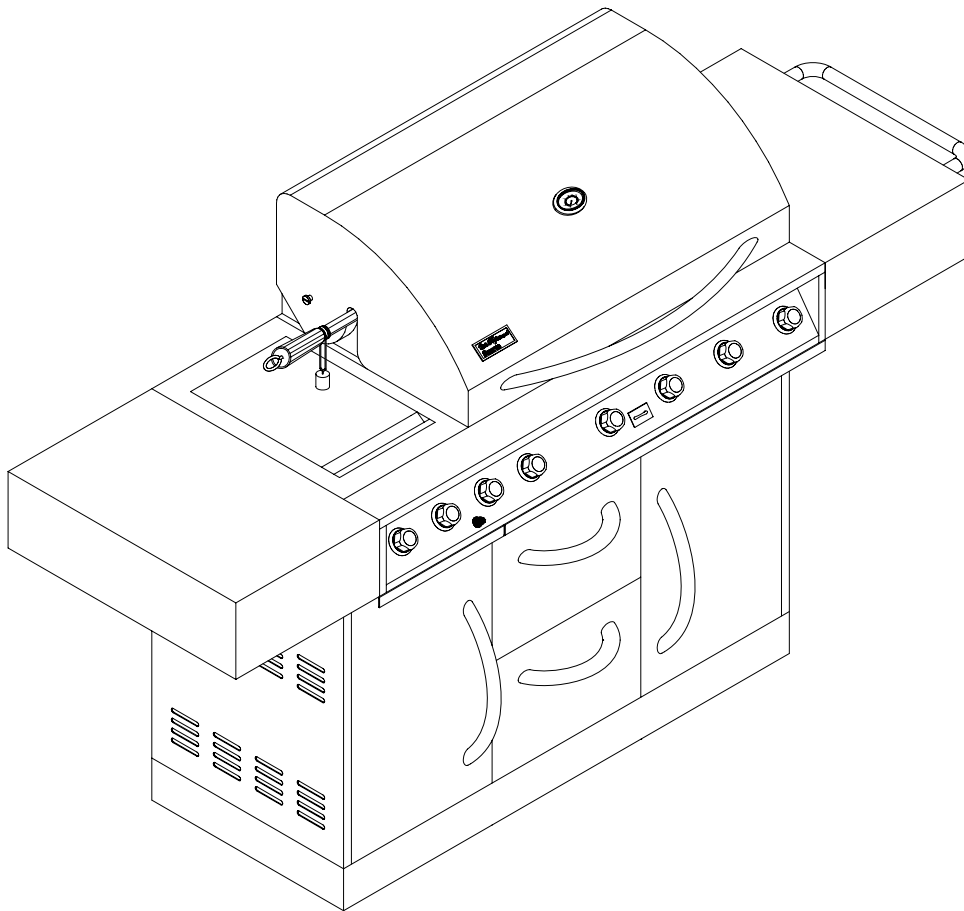

FOR OUTDOOR USE ONLY



**PLEASE CONTACT 1-800-913-8999 FOR ASSISTANCE
DO NOT RETURN TO PLACE OF PURCHASE**

TABLE OF CONTENTS

SECTION ONE

Safety Instructions.....	1~6
Natural Gas Safety.....	6

SECTION TWO

Installation of Side Shelves	7
Installation of Push Bar.....	8
Installation of Dividing Shelf.....	9
Installation of Battery.....	10
Installation of Nature Gas Regulator and Hose.....	11
Installation of Rotisserie kit.....	12
To Match light the Gill.....	13

SECTION THREE

Leak Testing.....	14
Installer Final Check.....	15

SECTION FOUR

Operating Instructions.....	15~16
Lighting Instructions.....	17

SECTION FIVE

Using the Side Burner.....	18
Care & Maintenance	18
Care & Maintenance of Side Burner.....	19
Trouble Shooting.....	19~21

SECTION SIX

Exploded View.....	22
Parts List	23
Grilling Hints.....	24
Grill Cooking Chart	25~26
Grill Recipe Suggestion	27~28

SECTION SEVEN

Limited Warranty	29
------------------------	----

Read this Care and Use Manual carefully and completely before using your grill to reduce the risk of fire, burn hazard or other injury.

SAFETY INSTRUCTIONS

*****  **WARNING** *****

FOR YOUR SAFETY

If you smell gas:

- 1. Shut off gas to the appliance.**
- 2. Extinguish any open flame.**
- 3. Open Lid.**
- 4. If odor continues, immediately call your gas supplier or your fire department.**

FOR YOUR SAFETY

Do not store or use gasoline or other flammable vapors and liquids in the vicinity of this or any other appliance.

SAFETY INSTRUCTIONS

WARNING

Do not try lighting this appliance without first reading the "LIGHTING INSTRUCTIONS" section of this manual.

DO NOT USE ALUMINUM FOIL TO LINE THE GRILL RACKS OR GRILL BOTTOM. This can severely upset combustion airflow or trap excessive heat in the control area.

INSECT WARNING!!! Spiders and insects can nest in the burners of this and any other grill, and cause the gas to flow improperly. This is a very dangerous condition, which can cause a fire to occur behind and beneath the valve panel, thereby damaging the grill and making it unsafe to operate. Inspect the grill twice a year.



WARNING

ELECTRICAL GROUNDING INSTRUCTIONS

This appliance (rotisserie motor) is equipped with a plug and should be plugged directly into a properly grounded receptacle. **DO NOT** cut or remove the grounding prong from this plug.

Keep the rotisserie motor electric cord away from the heated surfaces of the grill. When not in use remove and store the motor in a dry location



CAUTION: REMOVE THE WARMING RACK WHEN USING THE ROTISSERIE BURNER. THE HIGH HEAT COMING FROM THE BURNER MAY CAUSE THE WARMING RACK TO BEND.

DO NOT LEAVE THE GRILL UNATTENDED WHILE COOKING.

SAFETY INSTRUCTIONS

 **WARNING:** Always keep your face and body as far away from the burner as possible when lighting.

 **WARNING: IMPORTANT!**

BEFORE LIGHTING...

Inspect the gas supply hose prior to turning the gas “ON”. If there is evidence of cuts, wear, or abrasion, it must be replaced prior to use. Do not use the grill if the odor of gas is present. Only the pressure regulator and hose assembly supplied with the unit should be used. Never substitute regulators for those supplied with the grill. If a replacement is necessary, contact the factory for proper replacement.

Keep a spray bottle of soapy water near the gas supply valve and check the connections before each use.

Do not attempt to light the grill if odor of gas is present. Call for service 1-800-913-8999.

ROTISSERIE DRIVE MOTOR
USE ONLY FOR OUTDOORS, DO NOT EXPOSE TO RAIN.

 **CAUTION:** TO ENSURE CONTINUED PROTECTION AGAINST RISK OF ELECTRIC SHOCK, CONNECT TO PROPERLY GROUNDED OUTLETS ONLY, TO REDUCE THE RISK OF ELECTRIC SHOCK, KEEP EXTENSION CORD CONNECTION DRY AND OFF THE GROUND.

SAFETY INSTRUCTIONS

TESTED IN ACCORDANCE WITH ANSI Z21.58b-2002/CGA 1.6b-2002 STANDARD FOR OUTDOOR COOKING GAS APPLIANCES. THIS GRILL IS FOR OUTDOOR USE ONLY.

Check your local building codes for the proper method of installation. In the absence of local codes, this unit should be installed in accordance with the National Fuel Gas Code No. Z223.1-1988 and the National Electrical Code ANSI/NFPA No. 70-1990.

CALIFORNIA PROPOSITION

65-WARNING

The burning of gas fuel generates some byproducts, which are on the list of substances, which are known by the State of California to cause cancer or reproductive harm. California law requires businesses to warn customers of potential exposure to such substances. To minimize exposure to these substances, always operate this unit according to the use and care manual, ensuring you provide good ventilation when cooking with gas.

SAFETY PRACTICES TO AVOID PERSONAL INJURY

When properly cared for, your grill will give safe, reliable service for many years. However, extreme care must be used since the grill produces intense heat and that can increase accident potential. When using this appliance basic safety practices must be followed, including the following:

Do not repair or replace any part of the grill unless specifically recommended in this manual. All other service should be referred to a qualified technician.

CHILDREN SHOULD NOT BE LEFT ALONE OR UNATTENDED IN AN AREA WHERE THE GRILL IS BEING USED. NEVER ALLOW THEM TO SIT, STAND OR PLAY ON OR AROUND THE GRILL AT ANY TIME.

DO NOT STORE ITEMS OF INTEREST TO CHILDREN AROUND OR BELOW THE GRILL OR IN THE CART. NEVER ALLOW CHILDREN TO CRAWL INSIDE OF THE CART.

Never let clothing, pot holders or other flammable materials come in contact with or too close to any grate, burner or hot surface until it has cooled. Fabric may ignite and result in personal injury.

For personal safety, wear proper apparel. Loose fitting garments or sleeves should never be worn while using this appliance. Some synthetic fabrics are highly flammable and should not be worn while cooking.

Only certain types of glass, heatproof glass ceramic, earthenware, or other glazed utensils are suitable for grill use. These types of materials may break with sudden temperature changes. Use only on low or medium heat settings according to the manufacturer's directions.

Do not heat unopened food containers as a build-up of pressure may cause the container to burst.

Use a covered hand when opening the grill lid. Never lean over an open grill.

WHEN LIGHTING A BURNER, ALWAYS PAY CLOSE ATTENTION TO WHAT YOU ARE DOING. BE CERTAIN YOU ARE TURNING THE IGNITER LABELED FOR THE BURNER YOU INTEND ON USING.

SAFETY INSTRUCTIONS

When using the grill, do not touch the grill rack, burner grate or immediate surroundings as these areas become extremely hot and could cause burns. Use only dry potholders. Moist or damp potholders on hot surfaces may cause burns from steam. Do not use a towel or bulky cloth in place of potholders. Do not let potholders touch hot portions of the grill rack. Grease is flammable. Let hot grease cool before attempting to handle it. Avoid letting excess grease deposits collect in the grease tray at the bottom of the grill's firebox. Clean often.

For proper lighting and performance of the burners keep the burner ports clean. It is necessary to clean them periodically for optimum performance. The burners will only operate in one position and must be mounted correctly for safe operation.

Clean the grill with caution. Avoid steam burns; do not use a wet sponge or cloth to clean the grill while it is hot. Some cleaners produce noxious fumes or can ignite if applied to a hot surface.

Be sure all grill controls are turned off and the grill is cool before using any type of aerosol

cleaner on or around the grill. The chemical that produces the spraying action could, in the presence of heat, ignite or cause metal parts to corrode.

Do not use the grill for cooking excessively fatty meats or products, which promote flare-ups. Do not operate the grill under unprotected

combustible construction. Use only in well ventilated areas. Do not use in buildings, garages, sheds, breezeways or other such enclosed areas. **THIS UNIT IS FOR OUTDOOR USE ONLY.**

Keep the area surrounding the grill free from combustible materials, trash, or combustible fluids and vapors such as gasoline or charcoal lighter fluid. Do not obstruct the flow of combustion and ventilation air. If the unit is stored indoors ensure that it is cool.

Keep the back of the cart free and clear from debris. Keep any electrical supply cord, or the rotisserie motor cord away from the heated areas of the grill.

Never use the grill in extremely windy conditions. If located in a consistently windy area (oceanfront, mountaintop, etc.) a windbreak will be required (see below). Always adhere to the specified clearance.

SAFETY INSTRUCTIONS

CHECKING FOR GAS LEAKS

Never test for leaks with a flame. Prior to first use and at the beginning of each new season, you must check for gas leaks.

FOLLOW THESE STEPS:

1. Make soap solution by mixing one part liquid detergent and one part water.
2. Turn off heat control valves, and then turn on gas at source.
3. Apply the soap solution to all gas connections. Bubbles will appear in the soap solution if connections are not properly sealed. Tighten or repair as necessary.
4. If you have a gas leak that you cannot repair, turn off the gas at the source, disconnect the fuel line from grill and immediately call your grill dealer or gas supplier for professional assistance.

NATURAL GAS SAFETY

Your natural gas grill is designed to operate on natural gas grill only, at a pressure of water column (W.C.) 4" water column residential (1/4 psig or 1.75 kpa) regulated at the residential meter. Check with your gas utility for local gas pressure and with your local municipality for building code requirements. If your residential gas utility line pressure has not been regulated to 7" W.C. contact your local gas utility or gas grill dealer for professional assistance.

Check with your gas utility or with local building codes for instructions to install gas supply line, or call a licensed and knowledgeable installer.

It is recommended that an "ON-OFF" shut off valve be installed at the gas supply source; outdoors after the gas line piping exits outside the wall and before the quick-disconnect. In a branch fuel line, it should be installed before the

gas line piping enters the ground indoors in an accessible location near the supply line. Pipe sealing compound or pipe thread tape of the type resistant to the action of natural gas must be used on all male pipe threads when making the connection.

Disconnect your gas grill from its fuel source when the gas supply lines are being tested at high pressures by the gas company. This appliance and its individual shut off valve must be disconnected from the gas supply piping system during any pressure testing of that system at pressure in excess of 1/2 psi (3.5 kpa).

Turn off your gas grill when the gas supply is being tested at low pressures by the gas company. This appliance must be isolated from the gas supply piping system by closing its individual manual shut off valve during any pressure testing of the gas supply piping system at pressures equal or less than 1/2 psi (3.5kpa)

INSTALLATION OF SIDE SHELVES

The screws used to attached the side shelves are already screwed into the two side panels of the grill.

Remove the screws from the side panel and align with the holes in the left side panel. Then install the left shelf as shown in the figure below.

Repeat the above step to install the right shelf on right side panel.

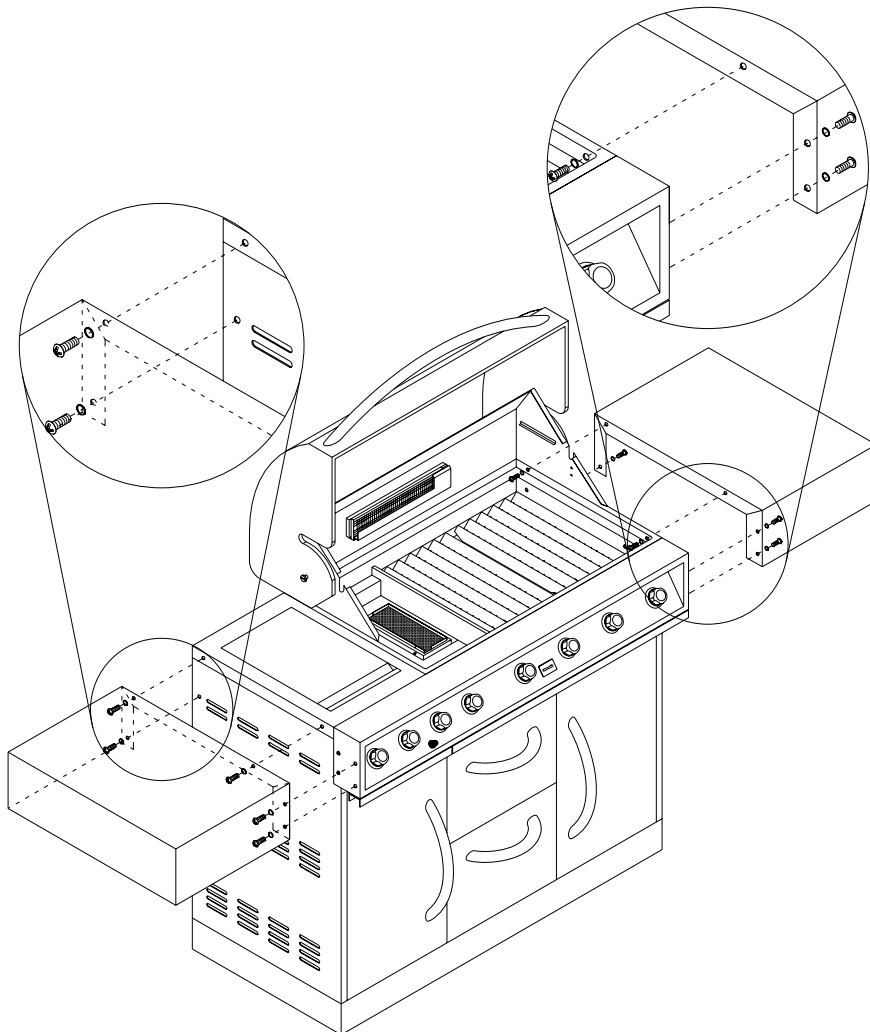

INSTALLATION OF PUSH BAR

The screws used to attach the push bar are already screwed into the two shelves. Remove the screws from the two side shelves, align with the holes in the push bar, and then re-screw into the holes on the two shelves of the grill. Press the cap against the ends of the push bar, and gently tap them into place..

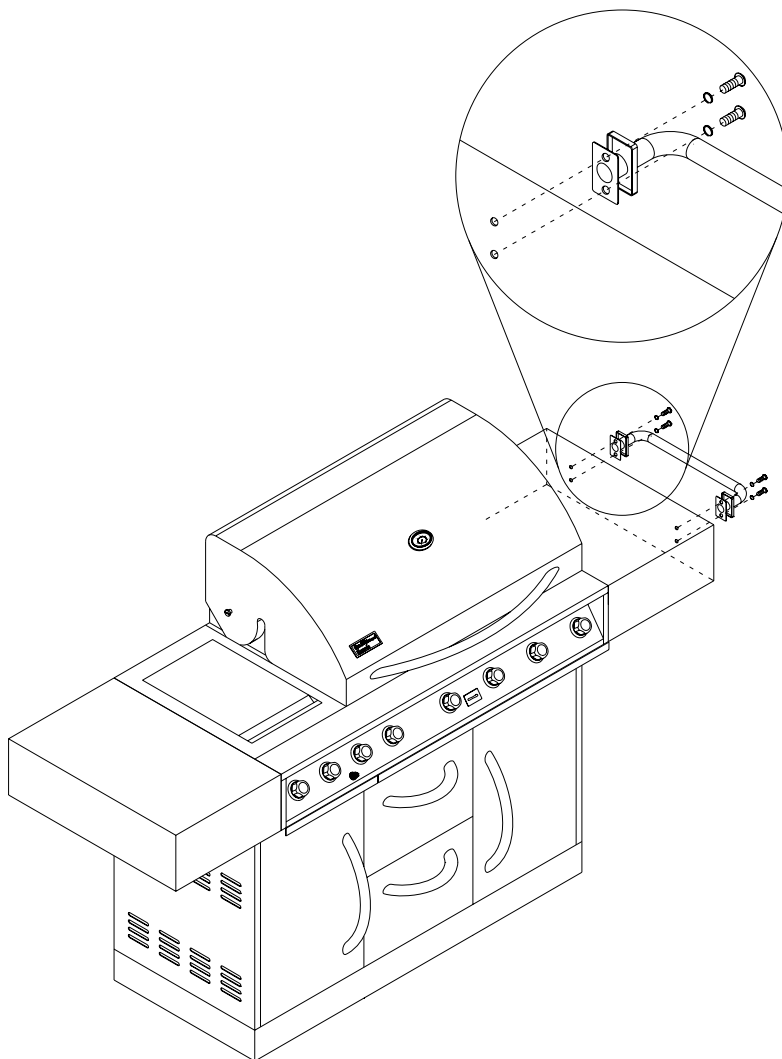

INSTALLATION OF SPICE TRAY AND DIVIDING SHELF

Put the spice tray into the hook on the right door.

Place the spice tray inside the right door. Assembly steps as shown in the figure below.

Place the dividing shelf inside the right door.

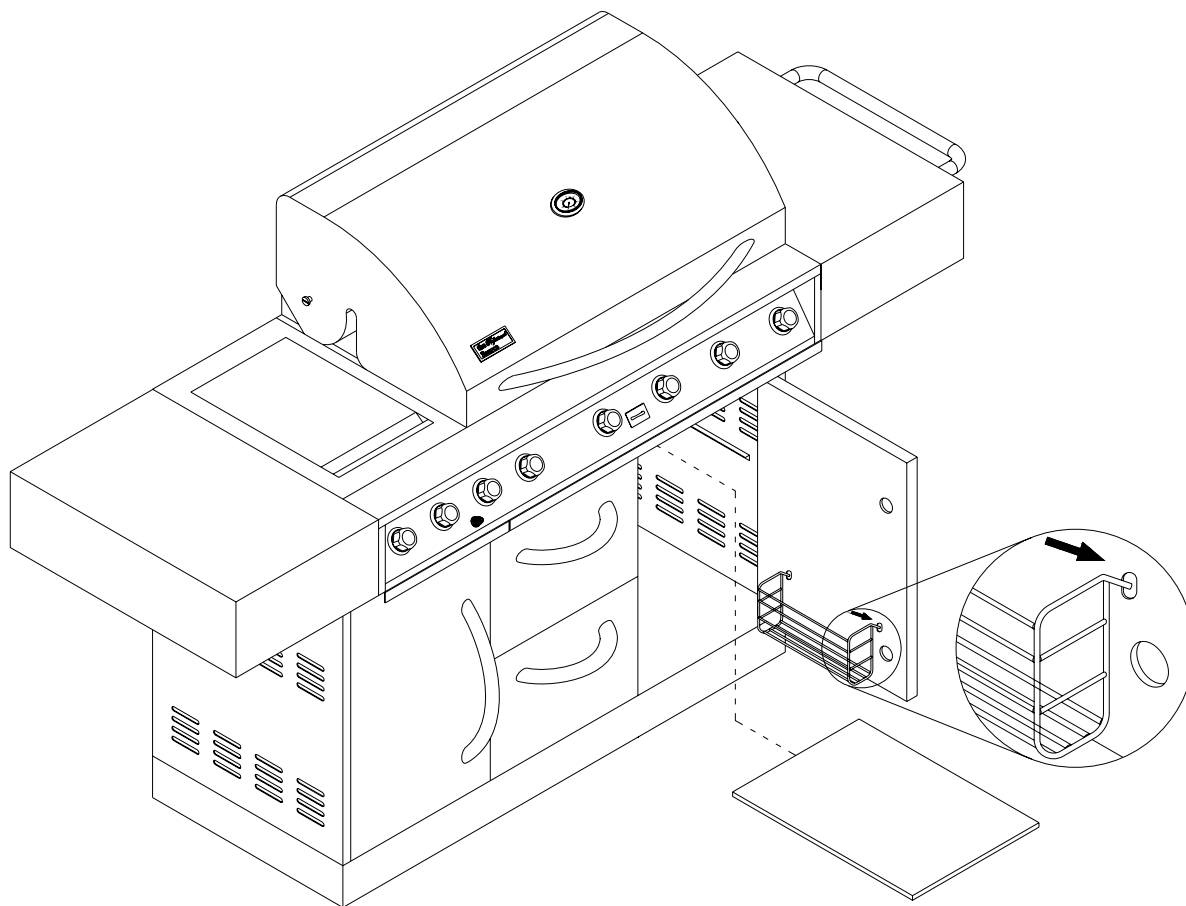

INSTALLATION OF BATTERY

In order to install the battery, remove the ignition button housing. Repeat the ignition button housing after battery is installed. Please keep the positive pole facing toward you. Tight the ignition button after installed the battery.

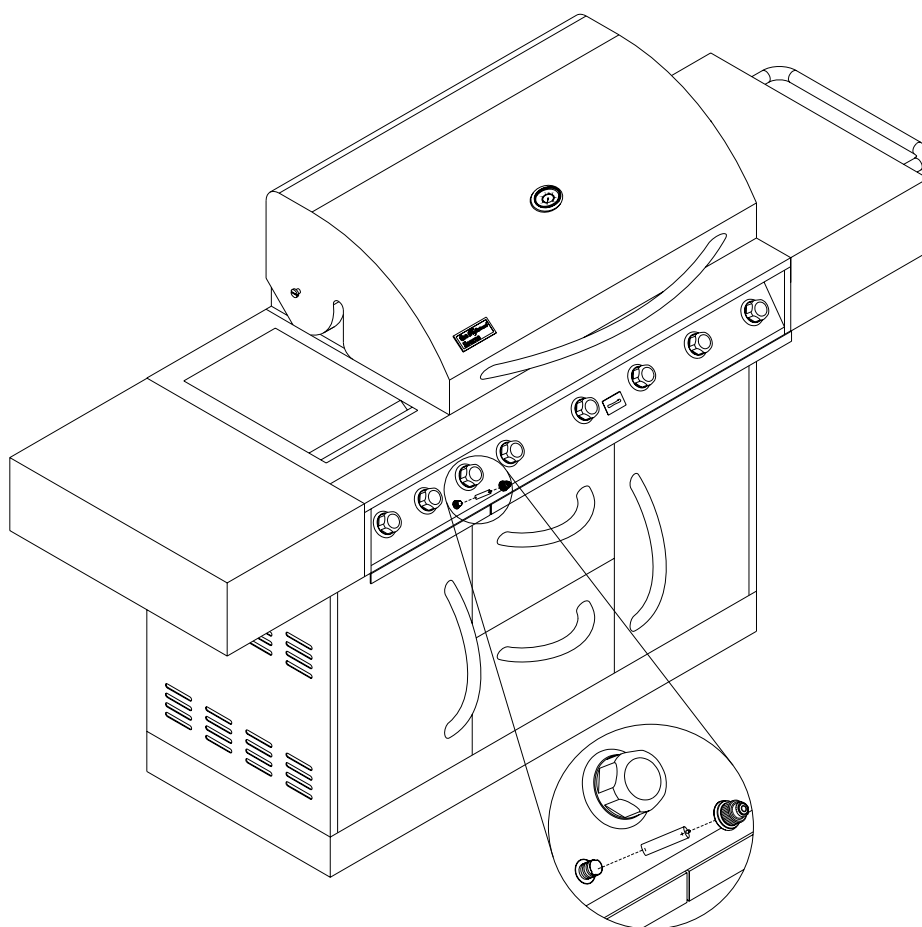

INSTALLATION OF NATURE GAS REGULATOR AND HOSE

The Nature Gas regulator has been factory installed. Attach the PVC Gas Hose to the regulator (See drawing below).

Connect the other end of the PVC Gas Hose to the house gas line using the quick-connect fitting.

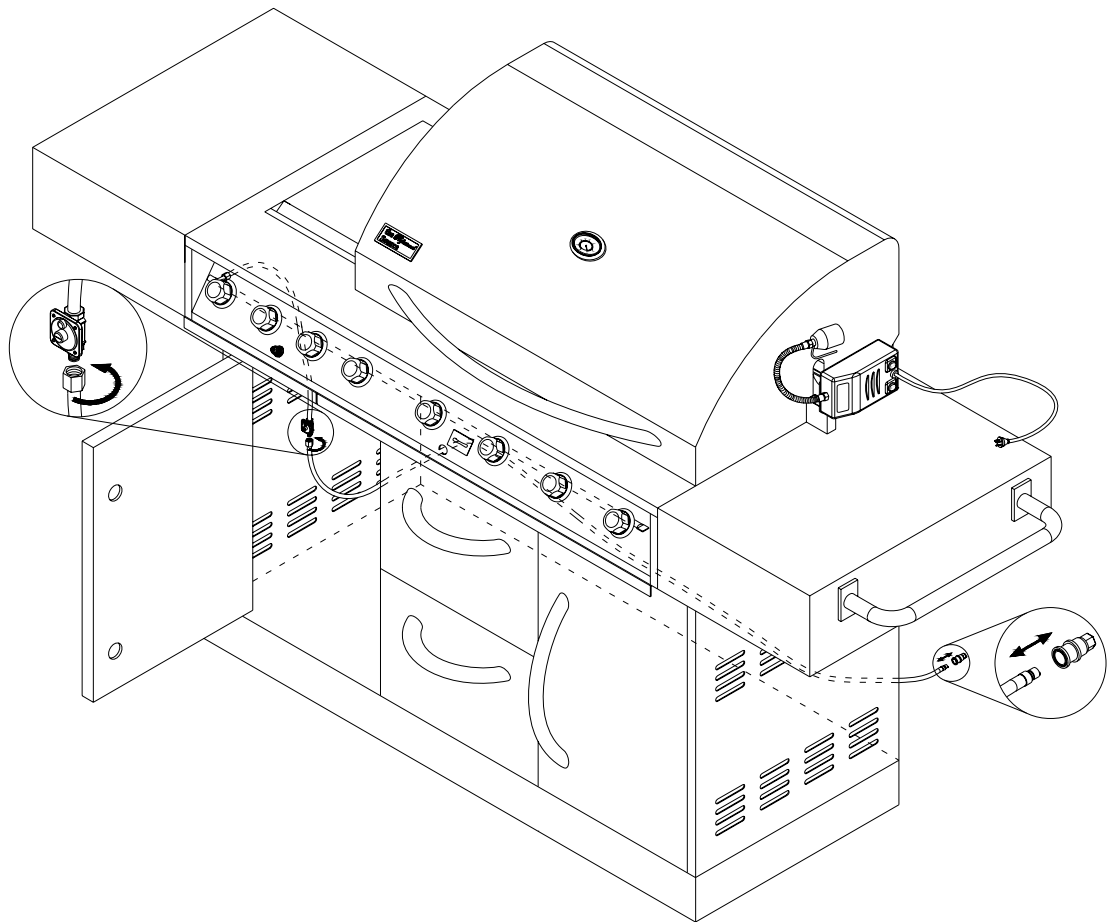

INSTALLATION OF ROTISSERIE KIT

The screws for rotisserie mount are already screwed into the rotisserie kit. After install the rotisserie motor mount, Assemble the rotisserie skewer as shown in the figure below.

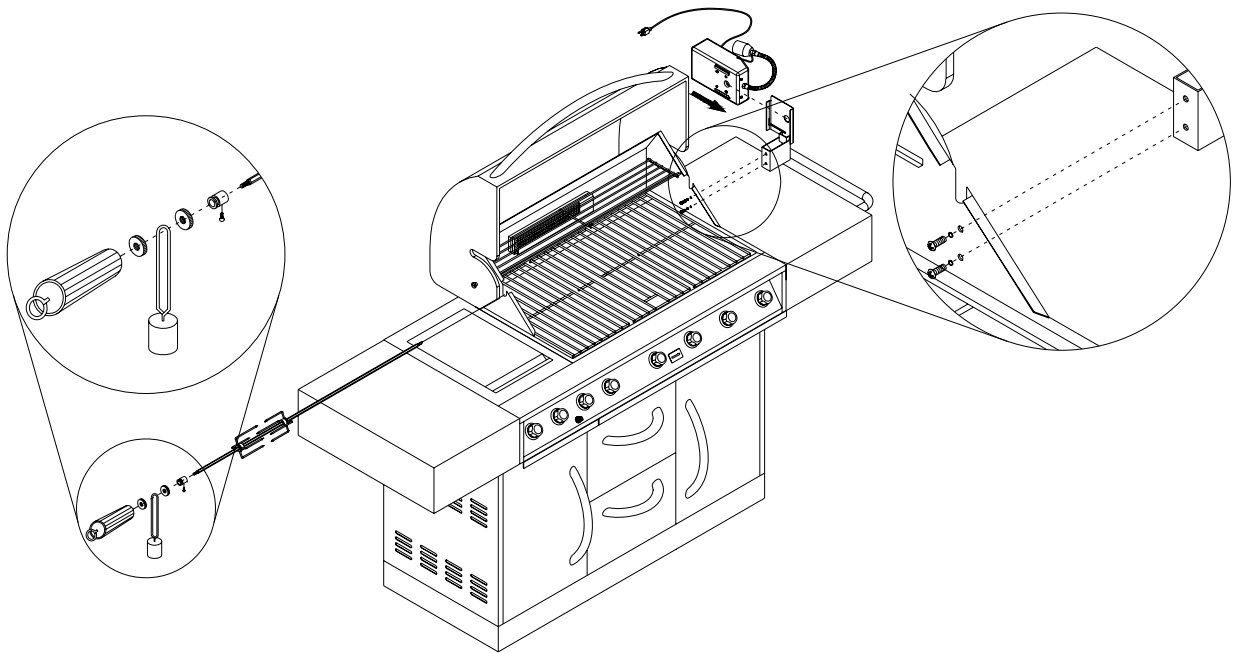

TO MATCH LIGHT THE GRILL

If the burner will not light after several attempts then the burner can be match lit. If you've just attempted to light the burner with the ignition, allow 5 minutes for any accumulated gas to dissipate. Keep your face and hands as far away from the grill as possible. Insert a lit extended match or lighter through the cooking grids to the burner. Press the control knob and rotate left to the HI setting, continue to press the knob until the burner ignites. Burner should light immediately. If the burner does not light in 4 seconds turn the knob off, wait 5 minutes and try again.

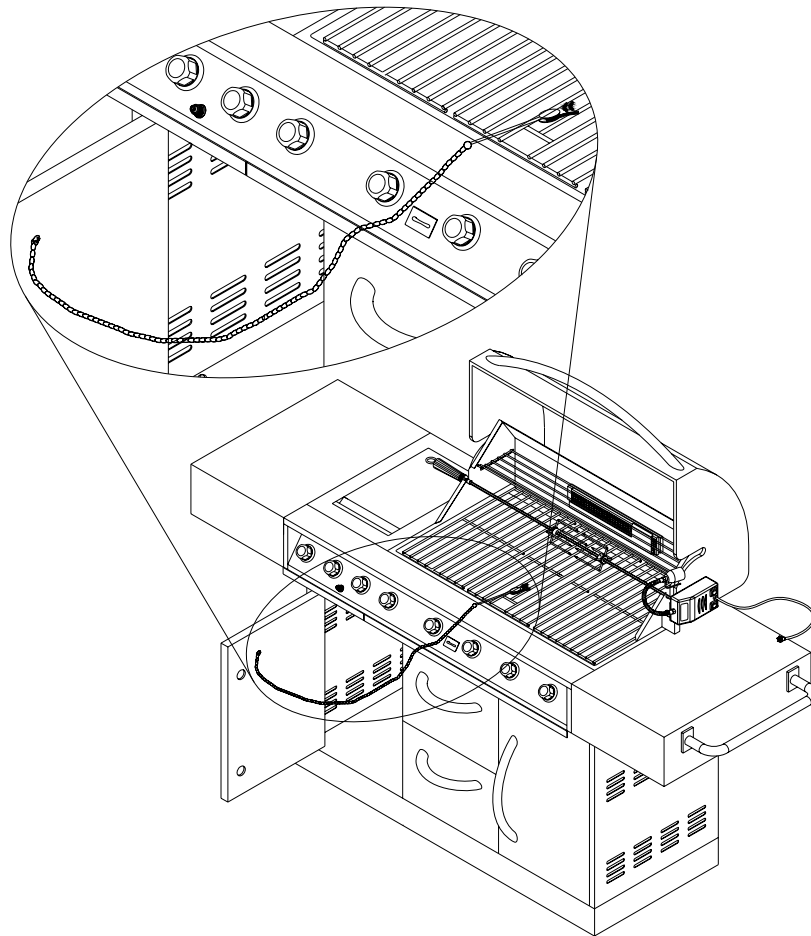

LEAK TESTING

GENERAL

Although all gas connections on the grill are leak tested at the factory prior to shipment, a complete gas tightness check must be performed at the installation site due to possible mishandling in shipment, or excessive pressure unknowingly being applied to the unit. Periodically check the whole system for leaks following the procedures listed below. If the smell of gas is detected at anytime you should immediately check the entire system for leaks.

BEFORE TESTING

Make sure that all packing material is removed from the grill including the burner tie-down straps.

DO NOT SMOKE WHILE LEAK TESTING.

NEVER LEAK TEST WITH AN OPEN FLAME.

Make a soap solution of one part liquid detergent and one part water. You will need a spray bottle, brush, or rag to apply the solution to the fittings. For the initial leak test, make sure the L.P. cylinder is full.

TO TEST

Make sure all control valves are in the "OFF" position. Turn the gas supply on. Check all connections from the L.P. cylinder up to and including the connection to the manifold pipe assembly (the pipe that goes to the burners). Soap bubbles will appear where a leak is present. If a leak is present, immediately turn off the gas supply, tighten any leaking fittings, turn gas on, and recheck. Should the gas continue to leak from any or all of the fittings, turn off the gas supply, and contact our customer service at 1-800-913-8999.

Only those parts recommended by the manufacturer should be used on the grill. Substitution will void the warranty. Do not use the grill until all connections have been checked and do not leak.

GAS FLOW CHECK:

Each grill burner is tested and adjusted at the factory prior

to shipment; however, variations in the local gas supply may make it necessary to adjust the burners, the flames of the burners should be visually checked.

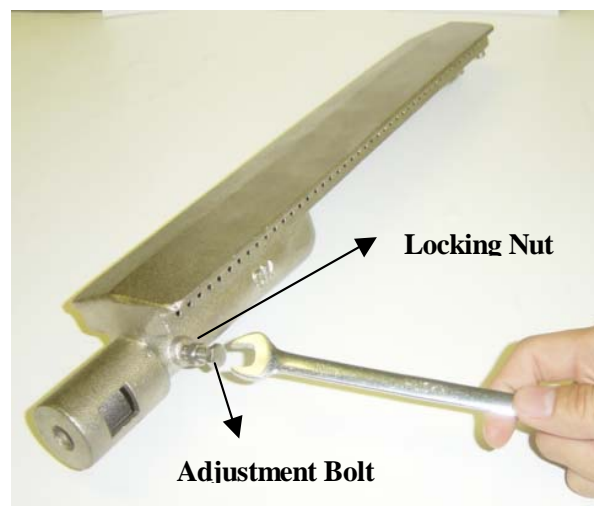

Flames should be blue and stable with no yellow tips, excessive noise or lifting. If any of these conditions exist, check to see if the air shutter or burner ports are blocked by dirt, debris, spider webs, etc. If you have any questions regarding flame stability, please call customer service at 1-800-913-8999.

ALWAYS CHECK FOR LEAKS AFTER EVERY LP TANK CHANGE

Check all gas supply fittings for leaks before each use. It is handy to keep a spray bottle of soapy water near the shut-off valve of the gas supply line. Spray all the fittings. Bubbles indicate leaks.

Disconnected L.P. cylinders must have threaded valve plugs tightly installed, and must not be stored in a building, garage or any other enclosed area.

The gas must be turned off at the supply cylinder when the unit is not in use.

If the appliance is stored indoors the cylinder must be disconnected and removed from the appliance. Cylinders must be stored outdoors in a well-ventilated area out of the reach of children.

INSTALLER FINAL CHECK

- Specified clearance maintained 24" from combustibles.
- All internal packaging removed.
- Knobs turn freely.
- Burners are tight and sitting properly on orifices.
- Pressure regulator connected and set for 11.2" W.C. LP gas. Gas connections to grill using hose & regulator assembly provided (pre-set for 11.0" water column).
- Unit tested and free of leaks.
- User informed of gas supply shut off valve location.

PLEASE RETAIN THESE INSTRUCTIONS FOR FUTURE REFERENCE.

OPERATING INSTRUCTIONS

General use of the grill and rotisserie

Each main burner is rated at 12,000 BTU/hr. The main grill burners encompass the entire cooking area and are side ported to minimize blockage from falling grease and debris. Above the burners are stainless steel radiant (flame tamers). The igniter knobs are located on the lower center portion of the valve panel. Each rotary igniter is labeled on the control panel.

USING THE GRILL:

Grilling requires high heat for searing and proper browning. Most foods are cooked at the "HI" heat setting for the entire cooking time. However, when grilling large pieces of meat or poultry, it may be necessary to turn the heat to a lower setting after the initial browning. This cooks the food through without burning the outside. Foods cooked for a long time or foods basted with a sugary marinade may need a lower heat setting near the end of the cooking time.

To begin:

1. Make sure the grill has been leak tested and is properly located.
2. Remove any remaining packing material.
3. Light the grill burners using the instructions on page 13.
4. Turn the control knob(s) to "HI" and preheat the grill for 15 minutes. The grill lid is to be closed during the appliance preheat period.
5. Place the food on the grill and cook to the desired doneness. Adjust heat setting, if necessary. The control knob may be set to any position between "HI" and "LO".

NOTE: The grill is designed to grill efficiently without the use of lava rocks or briquettes of any kind. Heat is radiated by the stainless steel flame tamers positioned above each burner.

NOTE: The hot grill sears the food, sealing in the juices. The longer the preheat, the faster the meat browns and the darker the grill marks.

OPERATING INSTRUCTIONS

USING ROTISSERIE BURNER:

Your grill is capable of performing back burner rotisserie cooking. Light the rear burner as described in the lighting instructions, once lit, the rotisserie burner will reach cooking temperatures in about 1 minute.

The rotisserie motor is capable of turning up to a 12lb. cut of meat or poultry. The motor slides onto the stainless steel motor mount. The rotisserie motor must be electrically grounded in accordance with local codes or, in the absence of local codes, with the National Electrical Code, ANSI/NFPA 70-1990.

DO NOT LEAVE THE GRILL UNATTENDED WHILE COOKING.

The skewers for the rotisserie are assembled into the motor assembly by placing the pointed end into the motor, and then sliding the grooved bushing into the slot at the opposite side of the grill. The thumbscrew for the grooved bushing should be inside the grill body. To load the skewer, begin with the bushing screwed on the skewer rod at the opposite end from the point. Slide the counter balance apparatus and tighten on the skewer rod approximately 2-4" from the bushing. Slide the first meat fork onto the skewer rod prongs toward the food. Center the product to be cooked on the skewer then push the meat forks firmly together. Tighten the wing nuts as tight as possible.

It may also be necessary to wrap the food with butchers string (never use nylon or plastic string) to secure any loose portions. Once the food is secure insert the skewer into the motor. It is normal for the skewer to flex when larger cuts of meat are being cooked. It may also be necessary to remove the cooking grids for larger cuts of meat. If the meat scrapes on the cooking grids during any part of the rotation, the grids must be removed. Adjust the counter balance weight to balance the heavier side of the meat and avoid lopsided rotation of the rotisserie motor.

After your first use of the rotisserie burner it is likely that the stainless steel adjacent to the burner will darken to a dark blue color. This is a normal property of the non-rusting, type 304 stainless steel used on the grill.

 **CAUTION: REMOVE THE WARMING RACK WHEN USING THE ROTISSERIE BURNER. THE HIGH HEAT COMING FROM THE BURNER MAY CAUSE THE WARMING RACK TO BEND.**

WARNING

ELECTRICAL GROUNDING INSTRUCTIONS

This appliance (rotisserie motor) is equipped with a plug and should be plugged directly into a properly grounded receptacle. DO NOT cut or remove the grounding prong from this plug.

Keep the rotisserie motor electric cord away from the heated surfaces of the grill. When not in use remove and store the motor in a dry location

LIGHTING INSTRUCTIONS

WARNING: IMPORTANT!

BEFORE LIGHTING...

Inspect the gas supply hose prior to turning the gas "ON". If there is evidence of cuts, wear, or abrasion, it must be replaced prior to use. Do not use the grill if the odor of gas is present. Only the pressure regulator and hose assembly supplied with the unit should be used. Never substitute regulators for those supplied with the grill. If a replacement is necessary, contact the factory for proper replacement.

Screw the regulator (type QCC1) onto the tank. Leak check the hose and regulator connections with a soap and water solution before operating the grill

TO LIGHT THE GRILL BURNER:

Make sure all knobs are "OFF" then turn on the gas supply from the LP tank. Always keep your face and body as far from the grill as possible when lighting.

Your grill has an exclusive patented built-in ignition. The igniter is built in to the valve. To ignite each burner simply push and turn the control knobs to the HI setting, you will hear the valve click as it sends a spark to the pilot flame. If the burner does not light, wait 5 minutes for any excess gas to dissipate and then retry.

FLAME CHARACTERISTICS

Check for proper burner flame characteristics. Each burner is adjusted prior to shipment; however, variations in the local gas supply may take minor adjustments necessary.

Burner flames should be blue and stable with no yellow tips, excessive noise, or lifting. If any of

these conditions exist call our customer service line. If the flame is yellow, it indicates insufficient air. If the flame is noisy and tends to lift away from the burner, it indicates too much air.

TO MATCH LIGHT THE GRILL:

If the burner will not light after several attempts then the burner can be match lit.

If you've just attempted to light the burner with the igniter, allow 5 minutes for any accumulated gas to dissipate. Keep your face and hands as far away from the grill as possible. Insert a lit extended match or lighter through the cooking grids to the burner. Press the control knob and rotate left to the HI setting, continue to press the knob until the burner ignites. Burner should light immediately. If the burner does not light in 4 seconds turn the knob off, wait 5 minutes and try again.

TO LIGHT THE ROTISSERIE BURNER:

Open the lid; push the knob for about 5 seconds without rotating. This will allow time for the gas to flow into the rear burner. Continue pushing for 5 seconds then turn the knob to the HI position, then press the igniter button to light the rotisserie burner. If the burner does not light, turn the control knob to "OFF". If the igniter does not function, follow the instruction above for match lighting.

Keep a spray bottle of soapy water near the gas supply valve and check the connections before each use.

Do not attempt to light the grill if odor of gas is present. Call for service 1-800-913-8999.

USING THE SIDE BURNER

WARNING: IMPORTANT!

USING THE SIDE BURNER:

Inspect the gas supply hose prior to turning the gas "ON". If there is evidence of cuts, wear or abrasion, it must be replaced prior to use. Do not use the side burner if the odor of gas is present.

 **WARNING:** Always keep your face and body as far away from the burner as possible when lighting.

LIGHT INSTRUCTION

To light the side burner, remove any cooking utensils from the burner grate. Push and turn the

control knob counterclockwise to the "HI" position. If the burner does not light, turn the control knob to "OFF". If the smell of gas is detected and the igniter is not functioning, immediately turn the control knob "OFF". Allow 5 minutes for any accumulated gas to dissipate. If the side burner igniter is not functioning, see the following section for match lighting.

MATCH LIGHTING

Hold a lit extended match or lighter near the side burner ports, turn the control knob counterclockwise to "HI". Move your hand immediately once the burner is lit. Rotate the control knob to the desired setting.

CARE & MAINTENANCE

STAINLESS STEEL

The grill is made from non-rusting and non-magnetic stainless steel. There are many different stainless steel cleaners available. Always use the mildest cleaning procedure first, scrubbing in the direction of the grain. To touch up noticeable scratches in the stainless steel, sand very lightly with dry 100 grit emery paper in the direction of the grain. Specks of grease can gather on the surfaces of the stainless steel and bake on to the surface and give the appearance of rust. For removal use an abrasive pad in conjunction with a stainless steel cleaner.

GRILL RACK

The easiest way to clean the grill is immediately after cooking is completed and after turning off the flame. Wear a barbeque mitt to protect your hand from the heat and steam. Dip a brass bristle barbeque brush in tap water and scrub the hot grill. Dip the brush frequently in the bowl of water. Steam, created as water contacts the hot grill, assists the cleaning process by softening any food particles. The food particles will fall and burn. If the grill is allowed to cool before cleaning, cleaning will be more difficult.

ENSURE THAT THE GAS SUPPLY AND THE KNOBS ARE IN THE "OFF" POSITION. MAKE SURE THE RANGE TOP BURNER IS COOL BEFORE REMOVAL.

GRILL BURNERS

Extreme care should be taken when moving a burner as it must be correctly centered on the orifice before any attempt is made to relight the grill. Frequency of cleaning will depend on how often you use the grill.

GRILL BURNER CLEANING

Ensure the gas supply is off and the knobs are in the "OFF" position. Make sure the grill is cool. Clean the exterior of the burner with a wire brush. Clear stubborn scale with a metal scraper. Clear any clogged ports with a straightened paper clip. Never use a wooden toothpick as it may break off and clog the port. Please note if insects or other obstructions are blocking the flow of gas through the burner, and if so you will need to call our customer service line: 1-800-913-8999.

GREASE TRAY CLEANING

The grease tray should be emptied and wiped down periodically and washed in a mild detergent and warm water solution. A small amount of sand or cat litter may be placed in bottom of grease tray to absorb the grease. Check the grease tray frequently, don't allow excess grease to accumulate and overflow out of the grease tray.

CARE & MAINTENANCE OF SIDE BURNER

SIDE BURNER CLEANING:

Clean the exterior of the burner with a wire brush. Clear any clogged burner ports with a straightened paper clip. Never enlarge the burner ports. Never use a wooden toothpick as it may break off and clog the port.

STAINLESS STEEL:

There are many different stainless steel cleaners available. Always use the mildest cleaning procedure first, scrubbing in the direction of the grain. Do not use steel wool, as it will scratch the surface. To touch up noticeable scratches in the stainless steel, sand very lightly with dry 100 grit sand paper in the direction of the grain.

SIDE BURNER GRATE:

The top burner grate is stainless steel. To avoid burns do not clean a hot grate. They may be wiped while in place with hot, soapy water, rinsed and wiped dry. Never immerse a hot grate in water.

TROUBLE SHOOTING

SPIDER AND INSECT WARNING!!!

Spiders and insects can nest in the burners of the grill and cause the gas to flow from the front of the burner. This is a very dangerous condition, which can cause a fire to occur behind the valve panel, thereby damaging the grill and making it unsafe to operate.

WHEN TO LOOK FOR SPIDERS

You should inspect the burners at least once a year or immediately after any of the following conditions occur:

1. The smell of gas in conjunction with the burner flames appearing yellow.
2. The grill does not reach temperature.
3. The grill heats unevenly.
4. The burners make popping noises.

BEFORE CALLING FOR SERVICE

If the grill does not function properly, use the following checklist before contacting your dealer for service. You may save the cost of a service call.

TROUBLE SHOOTING

PROBLEM	SOLUTION
When I light the grill it does not flame immediately.	<ul style="list-style-type: none"> --Make sure you have turn on the gas --Make sure it has spark while you are trying to ignite the burner. --Push in for approximately 5 second before to turn and ignite the grill. --Make sure your burner is clean.
Rotisseries burner will not light when the igniter button is pushed.	<ul style="list-style-type: none"> --Check to see if debris is blocking the electrode sparks. --Check to see there is spark that jumps to the burner from the electrode wire. If no spark is seen. --Check the battery located inside the button. Press and turn counter clockwise. --Check for loose wire connection. --Gently bend the electrode wire closer to the burner until a spark is seen to jump from the igniter to the burner when you press the starter button. --Dose the infrared back burner light when attempting to match light? If not, check did you turn on the gas.
Regulator makes noise.	<ul style="list-style-type: none"> --Vent hose on the regulator may be plugged or regulator may be faulty. --Ensure the vent hole on the regulator is not obstructed. Clear the hole, close the LP tank and gas control valves. Wait ten minutes and re-start. --When turning the LP tank valve on, do not cover vent hole on the regulator. --Check your flames for proper performance if the flames are not correct replace regulator.
Full size cover does not fit the grill.	<ul style="list-style-type: none"> --Cover may be incorrect for your grill. It may be a tight fit. Ensure the cover correct length for your grill. Measure it left to right. Compare to the grill's measurement. --Compare the location and size of the hood portion of the cover to your grill. --Spread the cover and allow it to relax, preferably in warm sunlight or in a warm room.

<p>Rotisserie motor will not turn</p>	<ul style="list-style-type: none"> --Check the voltage at the outlet. --If an extension cord is required, ensure it is a 16 gauges, grounded cord. --Ensure the on/off switch is on. --Ensure the load does not exceed the 40 pounds operational capacity. --Ensure the spit is fully inserted in the motor. --Ensure there is no encumbrance or drag.
<p>Grill only heats to 200-300 degrees.</p>	<ul style="list-style-type: none"> --Ensure the temperature gauge is functioning properly. Hold a flame to the probe or compare the grill gauge to an oven thermometer place in the grill. --Ensure correct start procedure. Prior to lighting grill, the gas control knobs should be off. The propane bottle should be off. If not, wait 15 minutes. Turn tank all the way on.. Turn left burner to ignite, wait 5 seconds ignite. Repeat for additional burners. --Check all gas connections for leaks with bubble test. If leaks are found, replace the part or tighten the fitting.
<p>Grill takes a long time to preheat.</p>	<ul style="list-style-type: none"> --Normal preheat 500-600degrees, takes about 10-15 min. Cold weather and wind may effect your preheat time. --If you are using volcanic rock or briquettes they can increase the preheat time and maximum temperature.

EXPLODED VIEW

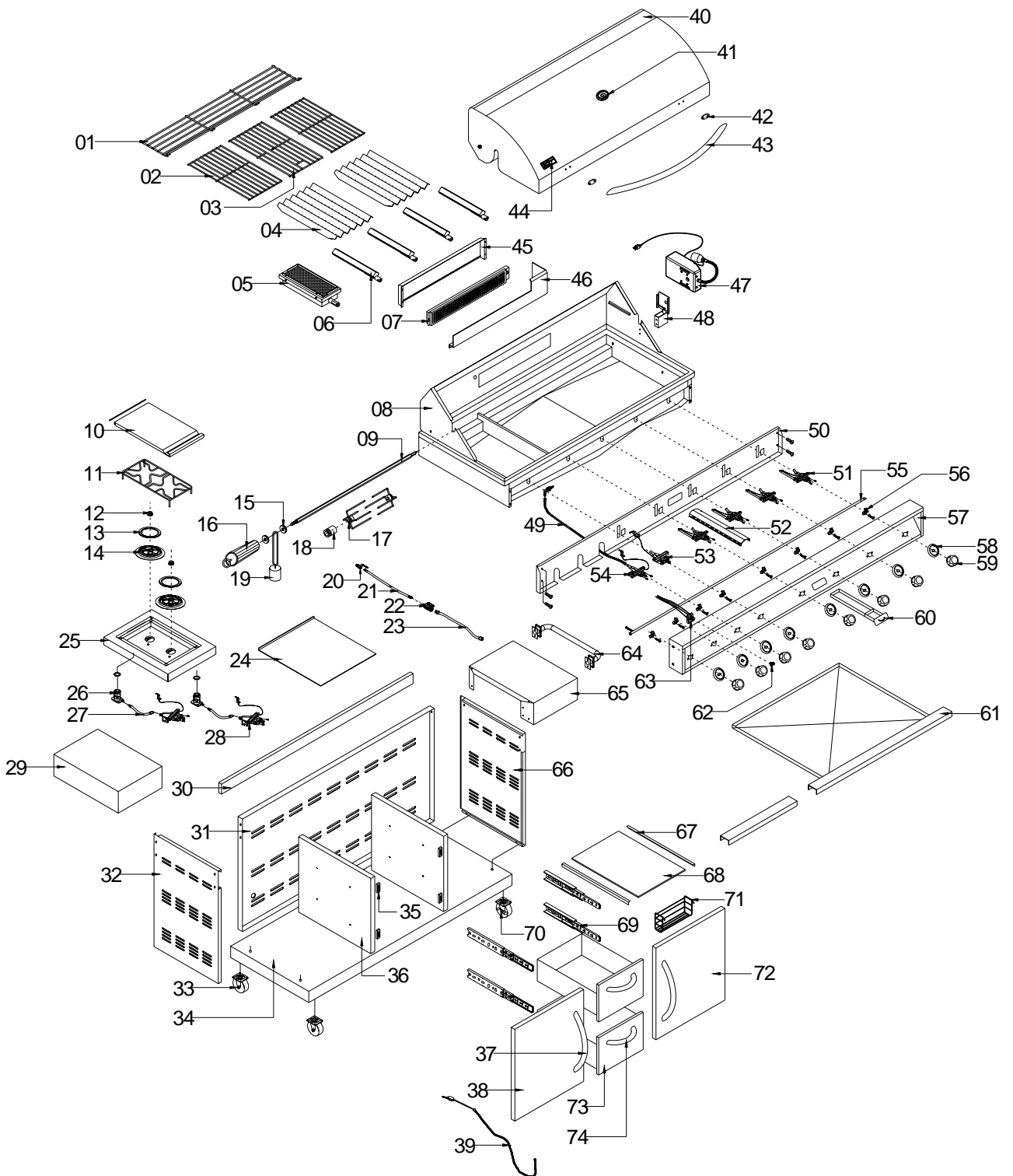

MODEL 730-0247 PARTS LIST

REF#	DESCRIPTION	Q'TY	REF#	DESCRIPTION	QTY
01	Warming Rack	1	38	Left Door	1
02	Cooking Grid	2	39	Lighting Rod	1
03	Cooking Grid With Hole	1	40	Lid, Front	1
04	Flame Tamer	4	41	Heat Indicator	1
05	Sear Burner	1	42	Heat Insulating Spacer	2
06	Main Burner	4	43	Handle Assembly, Lid	1
07	Rear Burner	1	44	Name Plate	1
08	Fire Box	1	45	Rear Baffle, Rear Burner	1
09	Spit Rod	1	46	Gas Collector, Rear Burner	1
10	Lid, Side Burner	1	47	Motor With Light	1
11	Cooking Grid, Side Burner	1	48	Motor Bracket	1
12	Side Burner Head	2	49	Gas Pipe, Rear Burner	1
13	Side Burner Ring	2	50	Front Baffle	1
14	Side Burner Body	2	51	Gas Valve, Main Burner	4
15	Key Washer	2	52	Smoker Tray Cover	1
16	Rotisserie Handle	1	53	Gas Valve, Sear Burner	1
17	Spit Fork	1	54	Gas Valve, Rear Burner	1
18	Shaft Collar	1	55	Manifold	1
19	Counter-Balance	1	56	Manifold Retainer Bracket	8
20	Gas Hose Adaptor	1	57	Control Panel	1
21	12' PVC Hose	1	58	Control Knob Seat	8
22	Regulator NG	1	59	Control Knob	8
23	PVC Gas Hose	1	60	Smoker Tray	1
24	Clapboard Drawer	1	61	Grease Tray	1
25	Bowel Assembly, Side Burner	1	62	Electric Ignition Button	1
26	Orifice Base, Side Burner	2	63	Electric Ignition	1
27	Gas Pipe, Side Burner	2	64	Side Shelf Handle	2
28	Gas valve, Side Burner	2	65	Side Shelf, Right	1
29	Side Shelf, Left	1	66	Right Side Panel, Cart	1
30	Cart Frame	1	67	Clapboard Bracket, Door	2
31	Back Panel, Cart	1	68	Clapboard, Door	1
32	Left Side Panel, Cart	1	69	Slide Assembly, Drawer	4
33	Caster	2	70	Caster With Brake	2
34	Bottom Panel, Cart	1	71	Spice Tray	1
35	Magnetic	4	72	Right Door	1
36	Clapboard, Cart	2	73	Drawer	2
37	Door Handle	2	74	Drawer Handle	2

GRILLING HINTS

The doneness of meat, whether rare, medium, or well done, is affected to a large degree by the thickness of the cut. Expert chefs say it is impossible to have a rare doneness with a thin cut of meat.

The cooking time is affected by the kind of meat, the size and shape of the cut, the temperature of the meat when cooking begins, and the degree of doneness desired.

When defrosting meats it is recommended that it be done overnight in the refrigerator as opposed to a microwave. This in general yields a juicier cut of meat.

Use a spatula instead of tongs or a fork to turn the meat, as a spatula will not puncture the meat and let the juices run out.

To get the juiciest meats, add seasoning or salt after the cooking is finished on each side and turn the meat only once (juices are lost when the meat is turned several times). Turn the meat just after the juices begin to bubble to the surface.

Trim any excess fat from the meat before cooking. To prevent steaks or chops from curling during cooking, slit the fat around the edges at 2-inch intervals.

DO NOT LEAVE THE GRILL UNATTENDED WHILE COOKING.

GRILL COOKING CHART

FOOD	WEIGHT OR THICKNESS	FLAME SIZE	APPROXIMATE TIME	SPECIAL INSTRUCTIONS AND TIPS
VEGETABLES				Slice. Dot with butter or margarine. Wrap in heavy-duty foil. Grill, turning occasionally.
Fresh: Beets Carrots Turnips		Medium	12 to 20 minutes	Grill, turning once. Brush occasionally with melted butter or margarine.
Onion	1/2 inch slices	Medium	8 to 20 minutes	Season with Italian dressing, butter, or margarine.
Potatoes Sweet	Whole	Medium	40 to 60 minutes	Wrap individually in heavy-duty foil. Grill, rotating occasionally.
White	6 to 8 ounces	High	45 to 60 minutes	
Frozen Asparagus Peas Green beans Sprouts Broccoli Brussels		Medium	15 to 30 minutes	Dot with butter or margarine. Wrap in heavy-duty foil. Grill, turning occasionally.
French fries		Medium	15 to 30 minutes	Place in aluminum foil pan. Grill, stirring occasionally.
FOOD	WEIGHT OR THICKNESS	FLAME SIZE	APPROXIMATE TIME	SPECIAL INSTRUCTIONS AND TIPS
MEATS BEEF				
Hamburgers	1/2 to 3/4 inch	Medium	10 to 18 minutes	Grill, turning once when juices rise to the surface. Do not leave hamburgers unattended since a flare-up could occur quickly.
Tenderloin, Porterhouse, Rib eye		High	8 to 15 minutes	
Rare	1 inch	High	8 to 14 minutes	Remove excess fat from edge. Slash remaining fat at 2-inch intervals. Grill, turning once.
Medium	1-1/2 inch 1 inch 1-1/2 inch	High Medium to High	11 to 18 minutes 12 to 22 minutes 16 to 27 minutes	
Well-done	1 inch 1-1/2 inches	Medium Medium	18 to 30 minutes 16 to 35 minutes	

Lamb Chops & Steaks Rare	1 inch	High	10 to 15 minutes	Remove excess fat from edge. Slash remaining fat at 2-inch intervals. Grill, turning once.
	1-1/2 inch	High	14 to 18 minutes	
	Medium	1 inch 1-1/2 inch	Medium to High	
Well-done	1 inch	Medium	17 to 30 minutes	
Pork Chops	1 inch	Medium	20 to 30 minutes	Remove excess fat from edge. Slash remaining fat at 2-inch intervals. Grill, turning once. Cook well done.
	Well-done	1-1/2 inches	Medium	
Ribs Pork		Medium	30 to 40 minutes	Grill, turning occasionally. During last few minutes brush with barbecue sauce, turn several times.
Ham steaks (precooked)	1/2 inch slices	High	4 to 8 minutes	Remove excess fat from edge. Slash remaining fat at 2-inch intervals. Grill, turning once.
Hot dogs		Medium	5 to 10 minutes	Slit skin. Grill, turning once.
POULTRY Broiler/fryer	2 to 3 pounds	Low or	1 to 1-1/2 hours	Place skin side up. Grill, turning and brushing frequently with melted butter, margarine, oil or marinade.
FOOD	WEIGHT OR THICKNESS	FLAME SIZE	APPROXIMATE TIME	SPECIAL INSTRUCTIONS AND TIPS
Breasts well-done		Medium	30 to 45 minutes	Marinate with Italian dressing
FISH AND SEAFOOD				Grill, turning once. Brush with melted butter, margarine or oil to keep moist.
Steaks Halibut Salmon Swordfish	3/4 to 1 inch	Medium to High	8 to 15 minutes	
Whole Catfish	4 to 8 ounces	Medium to	12 to 20 minutes	Grill, turning once. Brush with melted butter, margarine or oil.
Rainbow trout		High		Brush with melted butter and lemon juice.

GRILL RECIPE SUGGESTIONS

BBQ SALMON

2 large salmon steaks
2 tbs. oil
Salt & pepper
2 oz. thin bacon slices
2 tbs. butter
1 tbs. lemon juice
Sprig of parsley
Lemon wedges

Note: Substitute catfish, halibut or cod for salmon.

PREHEAT THE BBQ

Brush the steaks with oil and season with salt and pepper. Place on BBQ grill and cook for 10 minutes, turning steaks over halfway through cooking time.

Meanwhile fry the bacon in a pan on the side burner. Drain on paper towels. Melt the butter in a small saucepan taking care not to discolor it. Arrange the fish and bacon on serving plates. Pour the butter over and sprinkle with lemon juice. Garnish with parsley sprigs and lemon wedges. Serve with boiled potatoes in butter and sprinkled with parsley.

BAKED CHILI CORN

6 medium ears corn, husked
3 tbs. butter or margarine, melted
Dash ground cumin
Dash ground coriander

About ½ hour before cooking, turn the grill on for butter. Place each ear on a heavy-duty foil. In a bowl, combine remaining ingredients. Mix well. Brush 1-1/2 tsp. butter mixture over each ear. Close foil and fold up ends to seal. Place on grill. Cook, turning packets occasionally 10 to 12 minutes or until cooked through.

TANGY SEAFOOD KABOBS

1 lb. large shrimp, shelled & divined
¾ Lbs. Sea scallops
2/3 c. chili sauce
¼ c. cider vinegar
3 tbs. Chopped parsley
1 tbs. Vegetable oil
1 tbs. Worcestershire sauce
½ tsp. Prepared horseradish
1 clove garlic, minced

1 20 oz. Can pineapple chunks in juice drained In medium bowl, combine shrimp and scallops. In small bowl combine chili sauce and next six ingredients. Pour over seafood. Toss to coat. Cover, refrigerate 2 hours.

Half-hour before cooking, turn the burner to the grill on high. Drain seafood-reserving marinade. On each of twelve 10" skewers, thread 2 shrimps and 2 scallops, alternating with pineapple chunks. Place skewers on grill. Cook 7-10 minutes, basting and turning often.

PORK CHOPS

4 pork chops
Marinade
1 large onion
2 tbs. lemon juice or vinegar
2 tbs. oil
½ tsp. freshly ground black pepper.
1 tsp. sugar
½ tps. paprika
1 clover garlic
Peel, grate onion, and add rest of the ingredients except the pork chops. Mix well. Pour over chops and marinate one hour in a cool place. Turn the BBQ grill on high. Heat 10 minutes. BBQ the chops brushing with the marinade occasionally. Serve with mixed salad, dressed with vinaigrette flavored with fresh dill.

BARBECUED POTATOES AND CHEESE

1 –1/2 cups shredded cheddar cheese
1 can (10-3/4 oz.) condensed cream of mushroom soup
1/3 cup milk
2 tbs barbecue sauce
¼ tsp. oregano
¼ tsp. salt
1/8 tsp. pepper
4 cups thinly sliced potatoes
(4 medium-sized potatoes)

Preheat grill. Combine cheese, condensed soup, milk, BBQ sauce, oregano, salt and pepper in a large mixing bowl. Stir in potatoes until well coated. Turn into well-buttered 1-1/2 quart rectangular baking dish. Cover dish with

aluminum foil. Bake covered 25 minutes on medium with the lid of your BBQ grill closed. Remove foil and continue baking 15 minutes longer or until potatoes are tender. Let stand 5 minutes before serving.

BARBECUED LONDON BROIL

4 to 6 servings
¾ c. Italian dressing
1tsp. Worcestershire sauce
1tsp. Dry mustard
¼ tsp. Thyme, crushed
1 medium onion, sliced
1 pound flank steak, scoured
2 tbs. Butter, melted

Combine first 4 ingredients, add onion and marinade flank steak with it. Refrigerate at least 4 hours or overnight. Remove steak and grill on preheated BBQ grill. Grill 5 to 7 minutes on each side basting frequently with the marinade. In the meantime sauté onions from the marinade in butter in a skillet on grill side burner for 3 minutes. To serve, slice steak diagonally into thin slices, sprinkle onions over top. Garnish with vegetable kabobs.

VEGETABLE KABOBS

3 medium-size zucchini
12 cherry tomatoes
12 fresh mushrooms
Grated parmesan cheese

Parboil whole zucchini 5 minutes on grill side burner or until just tender. Drain and cut into ½ inch slices. Thread zucchini, tomatoes and mushrooms alternately on each of six skewers. Brush with marinade made of Italian dressing, Worcestershire sauce, mustard and thyme. Grill 5 to 7 minutes turning and basting occasionally. Sprinkle liberally with Parmesan cheese.

FAJITAS

1-1/2 lb. flank steak or boned chicken breasts
2 tbs. oil
½ cup lime juice

½ tsp. salt
 ½ tsp. celery salt
 ¼ tsp. garlic powder
 ½ tsp. pepper
 ¼ tsp. oregano
 ¼ tsp. cumin
 Flour tortillas
 Lemon

Pound flank steak to ¼ inch thickness or flatten chicken breasts. Mix oil, lime juice and seasonings in a zip lock bag. Add meat and shake bag to coat the meat. Refrigerate overnight or at least 6 to 8 hours. Wrap tortillas in foil. Remove meat from marinade. Cook on a pre-heated gas grill for 5 to 8 minutes on each side. While meat is cooking, heat tortillas on grill. Slice meat across grain in thin slices. Place on hot platter. Squeeze lemon juice over. Wrap meat and any of the following toppings in tortillas: chopped tomatoes, guacamole, sour cream, and taco sauce.

BEEF AND LAMB KABOBS

Serve 4
 ½ lb. boneless sirloin or beef cut into 1" cubes
 ½ lb. boneless loin of lamb cut into 1" cubes
 2/3 c. water, divided
 ¼ c. chopped onion
 2 tbs. soy sauce
 ¼ c. vegetable oil, divided
 1 tbs. dark brown sugar
 1 tbs. fresh lemon juice
 2 cloves garlic, minced
 ¼ tsp. ground cumin
 ¼ tsp. ground coriander
 ¼ tsp. ground turmeric
 1/8 tsp. ground red pepper
 1/8 tsp. ground ginger
 1 red pepper cut into chunks
 1 large banana, cut into chunks
 8 small mushrooms
 1/3 c. smooth peanut butter

In blender, process 1/3 c. water, onion, soy sauce, 2 tsp. oil and the next 8 ingredients until smooth. Pour over meat cubes and marinate about 4 hours, turning occasionally. Drain and reserve marinade. On to four 12" skewers alternately thread meat, pepper, banana and mushrooms. Preheat grill. Brush the kabobs with oil. Grill 7-8 minutes each side.

Bring marinade to boil on the side burner in a saucepan. Add remaining 1/3 c. water and peanut butter. Stir to blend. Heat through. If sauce gets too thick, add 1 tbs. water. Serve sauce with kabobs.

EGGPLANT CAVIAR

1 large eggplant
 2 tbs. olive oil
 2 tbs. wine vinegar
 2 tbs. finely chopped onion
 ½ clove garlic, minced
 1 medium tomato, chopped salt and pepper

Roast eggplant on gas grill over medium flame, turning occasionally until thoroughly cooked. This may take 30 minutes. Remove from grill and cool for handling. Strip off the skin and chop eggplant finely. Add all the seasonings. Chill thoroughly and serve on toast.

CHICKEN TANDOORI STYLE

8 large chicken thighs or drumsticks
 1 c. plain nonfat yogurt
 ½ c. lemon juice
 2 tsp. salt
 ½ tsp. cayenne
 ½ tsp. black pepper
 ½ tsp. crushed garlic
 ½ tsp. grated ginger
 1 tbs. corn oil

Combine all the ingredients in a large mixing bowl and marinate the chicken for 8 hours in the refrigerator. Drain the chicken and spread on the spit running the rod on the fleshier side of the bone.

Rotis using the rotis burner. Cook on medium high heat for 40 minutes basting occasionally with the remainder of the marinade mixture. Serve with sliced onions and lemon wedges.

SPARE RIBS

Marinade:
 1 c. soy sauce
 ½ c. honey
 ½ c. vinegar
 ½ c. dry sherry
 2 tsp. chopped garlic
 2 tsp. sugar
 1 c. water

1 chicken bouillon cube
 1 can beer for basting sauce

Marinate ribs for 3 hours. Use marinade for basting by adding beer to it. Place pan under the ribs and baste frequently. To cook ribs select lean, meaty ribs and accordion pleat them with your spit. Slide four-prong meat hook down the length of spit and tighten. At the beginning of the rack and to its center, penetrate the second rib with the pointed end of the spit and push it between the meat. Skip a couple and continue the process until the entire rack is accordion pleated. Fasten the second meat hook into the rack. Turn rotisserie burner on high. Rotisserie for 50 minutes or until done.

PORK ROAST

Apple cider vinegar basting sauce:
 1 c. apple cider vinegar
 6 oz. water
 ½ stick butter
 Salt, pepper, parsley and garlic seasoning
 2 oz. lemon juice
 10 lbs. pork roast

Time: 1-1/2 hours to 2 hours
 Bring pork to room temperature before placing it on the rotisserie spit rod. Place on the rod and test for balance. Light rotisseries burner. Turn control knob to high. Use the above basting sauce for rotissing.

TURKEY

12 lb. turkey
 Beer basting sauce:
 1 can beer
 12 oz. water
 1 stick butter
 1 tsp. salt
 1 tsp. pepper
 ½ tsp. garlic flakes
 1 tsp. parsley

Thaw the bird completely. Wash inside out. Securely tie the legs and wings. Before placing the turkey on the rotisserie spit rod, light rotisseries burner. Turn to high. Combine all the ingredients for basting sauce in a shallow pan. Place it under the turkey 15 to 20 minutes. Cook for approximately 3 hours. The basting sauce combined with turkey drippings makes delicious gravy.

LIMITED WARRANTY
MODEL 730-0247
STAINLESS STEEL OUTDOOR GAS GRILL

Nexgrill Industries, Inc. warrants to the original consumer purchaser of each Outdoor Gas Grill that when subject to normal residential use, it is free from defects in workmanship and materials for the periods specified below. This warranty excludes grills used in rental or commercial applications. There will be a shipping and handling charge for the delivery of the warranty part(s).

COMPONENT	WARRANTY PERIOD:
Burners:	5 Years
Stainless Flame Tamer with Ceramic Briquettes	3 Years
Stainless Steel Cooking Grids	3 Years
Valves	1 Year
Frame, Housing, Cart, Control Panel, Ignition, and Related parts	1 Year
All other S.S. parts	3 Years

Our obligation under this warranty is limited to repair or replacement, at our option, of the product during the warranty period. The extent of any liability of *Nexgrill Industries, Inc.* under this warranty is limited to repair or replacement. This warranty does not cover normal wear of parts, damage resulting from any of the following: negligent use or misuse of the product, use on improper fuel/gas supply, use contrary to operating instructions, or alteration by any person other than our factory service center. The warranty period is not extended by such repair or replacement.

WARRANTY CLAIM PROCEDURE: If you require service or parts for your grill, please contact our Warranty Service Center for factory direct assistance. Our hours of operation are 8 AM to 5 PM PST. Our number is 1-800-913-8999 and our FAX number is 1-909-598-8999. Please direct all correspondence to: *Nexgrill Industries, Inc. 280 Machlin Count City of Industry, CA 91789-3026 ATTN: Warranty Service Center.*

Product repair as provided under this warranty is your exclusive remedy. *Nexgrill Industries, Inc* shall not be liable for any incidental or consequential damages for breach of any express or implied warranty on its products. Except to the extent prohibited by applicable law, any implied warranty or merchantability or fitness for a particular purpose on this product to the duration of the above warranty. Some states do not allow the exclusion or limitation of incidental or consequential damages, or allow limitations on how long an implied warranty lasts, so the above limitations or exclusions may not apply to you. This warranty gives you specific legal rights, and you may have other rights, which vary from state to state.

Printed In China