



# OUTDOOR GAS INFRARED PATIO HEATER

## INSTALLATION, OPERATION, & MAINTENANCE MANUAL



Model TEGH48

Installation of TWIN EAGLES heater must only be performed by a person knowledgeable about gas appliance.

To the Installer:

Please read these instructions completely before installation and give this manual to the owner.

To the Owner:

Keep this manual in a safe place for future reference.

**NEED ASSISTANCE? PLEASE CALL:**

**(800) 789-2206**

TWIN EAGLES, INC.

13231 East 166<sup>th</sup> St.

Cerritos, CA 90703

(562) 802-3488

[www.twineaglesbbq.com](http://www.twineaglesbbq.com)



*A special message. . .*

Congratulations on your purchase of TWIN EAGLES outdoor gas infrared heater. We have designed this heater to provide you and your family with many years of great comfort heating experience. In addition to its Style, Performance and High Quality, this heater is built with pride in the U.S.A.

This manual gives you easy to follow instructions for installing, operating and maintaining your TWIN EAGLES heater. We recommend reading this manual carefully before your first use to insure safety, proper care and operation.

Thank you and welcome!

TWIN EAGLES

---

FOR YOUR RECORDS

Please record the following information and refer to them when contacting the company or an authorized service agent. The model number and serial number are found on the nameplate, located behind the component compartment door.

Model #: \_\_\_\_\_

Serial #: \_\_\_\_\_

Date of Purchase: \_\_\_\_\_

Place of Purchase: \_\_\_\_\_

Type of Gas:     NG         LP



## SAFETY PRECAUTIONS – GAS INFRARED HEATER

### FOR YOUR SAFETY: If you smell gas:

- 1) Open windows.
- 2) DO NOT try to light any appliance.
- 3) DO NOT use electrical switches or flashlights.
- 4) DO NOT use any telephone or cell phone in the building. Leave the building and immediately call your local gas supplier and follow the gas supplier's instructions. If you cannot reach your gas supplier, call the Fire Department.



### **WARNING**

#### **FIRE HAZARD**

Do not store or use gasoline or other flammable vapors and liquids in the vicinity of this or any appliance. Failure to follow these instructions can result in death, injury or property damage.

#### **ASPHYXIA, EXPLOSION or FIRE**

Improper installation, adjustment, alteration, operation, service or maintenance may create a hazard resulting in asphyxiation, explosion, fire, or damage to the equipment.

### **WARNING**

Never block the front grille of the heater.  
The heater is not suitable for hazardous locations.  
This unit may be a source of possible shock and ignition.

### **WARNING**

- The heater should only be installed by a qualified technician in accordance with all requirements of the authority having jurisdiction. The technician must be knowledgeable, specifically trained and experienced in the installation of this type of gas equipment.
- Read these instructions thoroughly for proper installation, operation, service or maintenance instructions before installing or servicing this heater.
- Improper installation, adjustment, alteration, service or maintenance can result in death, injury or property damage.

#### **PROP. 65 CARBON MONOXIDE WARNING!!!**

If not installed, operated and maintained in accordance with manufacturer's instructions, this product could expose you to substances in the fuel or from combustion, including Carbon Monoxide, which can cause death or serious illness and which is known to the State of California to cause cancer, birth defects or reproductive harm.

#### **WEATHER CONDITIONS WARNING**

These heaters must be protected from rain, ocean spray, moisture and high wind. If these heaters are exposed to these elements, it is quite possible that the valve and control system may not function properly which may create a fire or explosion hazard to customers.

- This warranty does not apply to gas heaters that are NOT protected from rain, ocean spray, moisture and strong wind.



## TABLE OF CONTENTS – GAS INFRARED HEATER

Safety Precautions.....	1
TWIN EAGLES GAS INFRARED HEATER features.....	3
Gas Installation Requirements.....	4-5
Leak Test Procedure.....	6
Selecting Mounting Location (Bracket Assembly).....	7-10
Mounting Clearances.....	11-12
Electrical Instruction (Battery Installation).....	13
Operating Instructions (Remote Control Synchronization).....	14-16
Preventive Maintenance.....	17
Troubleshooting Guide.....	18-19
Replacement Parts List (Use only TWIN EAGLES replacement parts).....	20
Limited Product Warranty.....	21
Warranty Registration Card	

SAVE THIS MANUAL FOR FUTURE REFERENCE



## TWIN EAGLES – GAS INFRARED HEATER FEATURES

TWIN EAGLES Gas Infrared Heater extends the outdoor activities during the cool days of fall and through the winter seasons providing a comfortable warm & inviting environment for your family & friends. Some of the TWIN EAGLES **GAS INFRARED HEATER** features are;

- Wall mounted wireless remote control (Lithium batteries included).
- Two Heat Levels; 25,000 BTU Low Setting & 37,000 BTU High Setting.
- Stainless Steel Welded Housing Construction
- No electrical wiring required. Battery operated gas control valve (AA batteries included).
- Spark Ignition with 100% Safety Pilot.
- Slim profile (TEGH48; W=9" x L= 48" x D= 8")
- Angle mounting Stainless Steel brackets provides the option of Zero or 30 degree mounting to direct the radiant heat towards a desired area in variety of outdoor patio applications.
- Decorative Safety Grille that provides shielding from wind. Wind proof up to 15 MPH.
- Great option for patios with limited floor space or high traffic areas.
- NG (Natural Gas) or LP (Liquified Petroleum Gas or Propane). Gas Conversion kits available
- Optional 120V AC adapter (usage is optional).
  - Comes standard with;
    - √ Stainless Steel 16 gauge mounting brackets.
    - √ Flexible gas hose approved for NG or LP installation.
    - √ Wall mounted wireless remote control (Lithium batteries included).

### **GETTING STARTED:**

- 1) Inspect the packaging for any physical damage, followed by checking the gas heater inside. If there is significant damage to the heater, report the damage to the carrier immediately.
- 2) Check to ensure that all the heater accessories are included.
- 3) Remove all packaging materials, labels and protective plastic film. **DO NOT LEAVE UNIT UNDER THE SUN WITH PROTECTIVE PLASTIC FILM ON FOR A LONG PERIOD OF TIME AS IT WILL BE DIFFICULT TO REMOVE THE FILM.**
- 4) Read the installation, operation and maintenance manual thoroughly before installing this heater.



## **GAS INSTALLATION REQUIREMENTS – GAS INFRARED HEATER**

Each patio heater is set and tested at the factory for the type of gas supply to be used. Identify the type of gas, either natural gas or LP gas and make sure that the marking on the nameplate (rating plate) matches the gas being supplied to the heater. The nameplate is located behind the component compartment access door.

### **1. CODE REQUIREMENTS**

- a) Installation must be in accordance with local codes, or in the absence of local codes, with the latest edition of the National Fuel Gas Code, ANSI Z224 and National Electrical Code ANSI/NFPA 70, and for Canada, the latest edition of CAN/CGA-B149.1 and B149.2 and Canadian Electrical Code, CSA C22.1 Part 1 and Part 2.
  - o Heaters to be installed in Aircraft hangars must be installed in accordance with American National Standards for Aircraft Hangars, ANSI/NFPA No. 409.
  - o Heaters to be installed in Public Garages must be installed in accordance with NFPA No. 88A, Standards for Parking Structures.
  - o Heaters must be installed so that minimum clearances marked on the heaters will be maintained from vehicles parked below the heater.
- b) When equipped with an AC/DC adapter, the heater must be electrically grounded in accordance with the National Electrical Code, ANSI/NFPA 70, when an external electrical source is utilized. In Canada, the CSA Canadian Electrical Code, C22.1 Part 1 applies.

### **2. GAS SUPPLY**

It is important that the inlet gas piping system be adequately sized for the heater(s) it serves. The gas inlet and manifold pressure required for the heater is listed below. For gas supply line pressures in excess of ½ psig, consult with your representative or the factory.

<b>Gas Inlet Pressure</b>	<b>Nat Gas</b>	<b>Propane</b>
Maximum Pressure	10" W.C.	13" W.C.
Minimum Pressure	6" W.C.	11" W.C.
Manifold Pressure	5" W.C.	10" W.C.

- a) A minimum pipe size of ½" is required for inlet piping. A ½" lever handled shut-off gas valve should be installed within 6 feet of the appliance for servicing the unit.
- b) Check with local and state plumbing and heating codes regarding sizing of gas lines.
- c) All gas pipe connections to the heater(s) must be sealed with a gas pipe compound resistant to liquefied petroleum gases.



- d) Installation of a drip leg in the gas supply line going to each heater is required to minimize the possibility of any loose scale or dirt within the gas supply line from entering the heater's control system.
  - e) When checking for gas leaks, do not use an open flame. Use the Leak Test procedures using liquid soap and water solution
  - f) For gas supply line pressures in excess of ½ psig, consult the factory or your local representative.
  - g) Installation of 1/8" N.P.T. plugged tapping accessible for test gage connections is required upstream of the gas supply connections to the heater.
- 3.** All gas connections should be made by a qualified technician in accordance with all requirements of the authority having jurisdiction. The technician must be knowledgeable, specifically trained and experienced in the installation of this type of gas equipment and related gas system components and with all precautions required regarding this type of equipment. Some states or provinces require installation and service personnel to be licensed. If your state or province is such, be sure your contractor bears the appropriate license. If a person does not meet all requirements and is not qualified for this installation he/she shall not attempt to repair, replace, install nor do any other type of work or service to this equipment.

If you do not fully understand these instructions, contact your Twin Eagles representative or the factory prior to performing installation or servicing.



## LEAK TEST PROCEDURE

### CAUTION BEFORE TESTING

- Finding and/or fixing a gas leak is NOT a “DO-IT-YOURSELF” procedure.
- NEVER USE THE PATIO HEATER WITHOUT FIRST LEAK TESTING THE GAS CONNECTIONS.
- WARNING: DO NOT USE OPEN FLAME TO CHECK FOR LEAKS. USE OF AN OPEN FLAME COULD RESULT IN A FIRE, EXPLOSION AND BODILY HARM.
- DO NOT SMOKE WHILE PERFORMING THE LEAK TEST!
- To prevent fire or explosion hazard, DO NOT use or permit sources of ignition in the area while performing a leak test. Perform leak test outdoors only.
- Check to ensure that the flexible hose does not have any cuts and wear that may affect the safety before each use. Only the factory supplied hose and regulator must be used. Use only replacement regulator and hose assemblies specified by Twin Eagles.
- If you are using a propane tank, check to ensure that there are no holes, dents, rusted weak spots, cracks, or other damage on the propane tank. If any damage is detected, the tank should be replaced immediately.

### LEAK TEST

- 1) Prepare a leak testing solution of sudsy water by mixing in a spray bottle with half liquid soap and half water.
- 2) Confirm that the heater is in the OFF position.
- 3) Turn the main gas valve supply ON.
- 4) Apply leak testing solution by spraying on the pipe joints, valve fittings and hose.
- 5) A gas leak is detected if;
  - a) there is a faint gas smell and/or...
  - b) growing bubbles appear on any of the connection points and/or hose. DO NOT attempt to ignite the heater and IMMEDIATELY turn off the gas supply valve.
- 6) When there is a gas leak, call a qualified service technician. DO NOT use the heater until the leak is corrected.





## SELECTING MOUNTING LOCATION – GAS INFRARED HEATER

When selecting a location to install the TWIN EAGLES Gas Infrared Heater, all the following factors must be met before the installation process:

### 1. ANCHORING TO WALL OR CEILING

**If the heater is not anchored to support at least 100 lbs. (45 ½ kg.) it could be a Suspension Hazard.** Failure of the supports can result in death. Local codes regarding head clearance requirement must be observed. Heaters shall be mounted in a fixed position independent of gas and electrical supply.

**NOTE:** Use only the mounting brackets provided by the manufacturer. Heater must be leveled only on a Horizontal Axis but can be angled to a maximum of 30 degrees in reference to the floor. **DO NOT** mount the heater on a vertical axis. Such installation is considered unsafe and improper and will automatically **VOID** the product's warranty.

### 2. COMBUSTIBLE MATERIALS

Combustible means material that can quickly catch fire if it comes in contact with sparks or fire. The Twin Eagles heater is a remote controlled unit that strictly requires that each heater must be installed such that the “**MINIMUM CLEARANCE TO COMBUSTIBLES**” are always met and maintained. **CAUTION** should be taken when heaters are used near glass, vinyl siding or other temperature sensitive construction materials. In some cases it may be necessary to increase the clearance around the heater to avoid damage to vinyl siding. Check with the manufacturer of the material siding for details

### 3. WEATHER CONDITIONS

This gas heater has been designed, tested and approved for outdoor installation; however, it is imperative that these heaters are protected from rain, ocean spray, moisture and high wind. If these heaters are exposed to these elements, it is quite possible that the valve and control system may not function properly which may create a fire or explosion hazard to customers.

### 4. FIRE SPRINKLERS

Fire Sprinklers must be located at an appropriate distance from each heater to avoid accidental activation of the sprinkler. **Ethylene glycol, propylene glycol, antifreeze solutions or any other potentially flammable substance must never be used in fire sprinkler systems where heaters are present as these substances may become flammable when heated.** A fire sprinkler



professional must be consulted when heaters are installed where fire sprinklers are present to ensure that heaters and the fire sprinkler system are properly integrated. Specific guidelines can be found in NFPA 13 regarding design and specifications for Fire Sprinkler Systems near heaters.

**5. VENTILATION**

- a) It is required that areas above the heater be properly vented to allow for necessary combustion air and removal of combustion gases.
- b) DO NOT obstruct the flow of combustion and ventilation air to this heater. If using a propane tank, keep the ventilation openings free and clear from debris.
- c) Heater must be in a location that allows uniform air pressure around the entire heater.
- d) Heaters shall be provided with natural or mechanical means to supply and exhaust at least 4 CFM per 1,000 BTU per hour of heater input. This equates to 150 CFM. Exhaust opening for removing the flue products shall be above the level of the heaters.
- e) Heater ventilation must comply with state and local codes.

**6. DESIRED HEATING AREA COVERED**

<u>Model</u>	<u>Mounting</u> <u>Height</u>	<u>Cold-</u> <u>Breezy</u>	<u>Mild</u>	<u>Well</u> <u>Protected</u>	<u>Heater</u> <u>Length</u>	<u>Volts</u>
TEGH48	8ft. – 9ft.	6 ft. x 6 ft	8 ft. x 8 ft.	10 ft. x 10 ft.	48 in.	6 VDC



## 7. PATIO DESIGN CONSIDERATION

Heater placement is critical for effective and efficient patio heating. If heaters are placed too close together or mounted too low, people become uncomfortable. If the heaters are placed too far apart on a breezy or wind-swept patio area, the patio may never get warm. Gas Infrared heaters work best if they are placed in areas of the greatest heat loss, such as the open side of a semi-protected patio area.

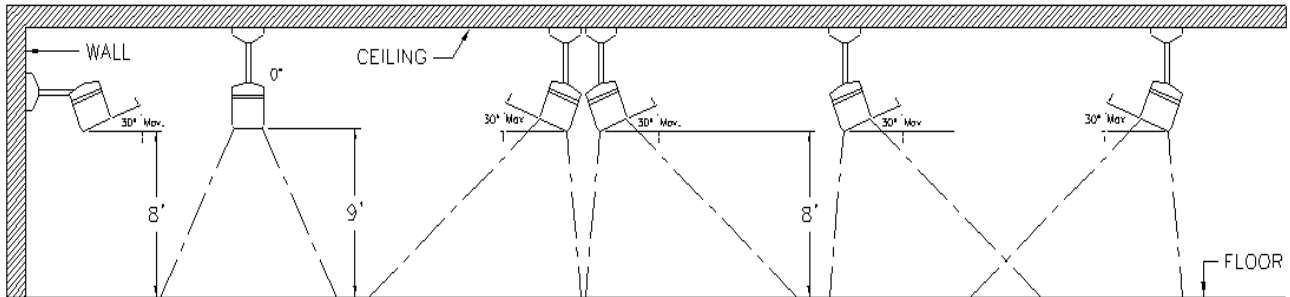

### ➤ MOUNTING BRACKET ASSEMBLY

**Angle mounting:** The heater may be angle-mounted to a maximum of 30° maximum to accommodate mounting the heaters around the edges of the patio or under eaves.

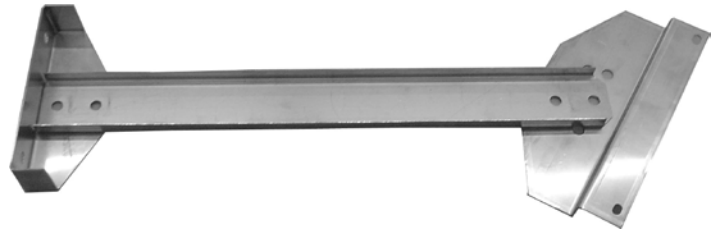

**NOTE:** Use only the mounting brackets provided by the manufacturer. Heater must be leveled only on a **Horizontal Axis** but can be angled to a maximum of 30 degrees in reference to the floor. **DO NOT** mount the heater on a vertical axis. Such installation is considered unsafe and improper and will automatically **VOID** the product's warranty.

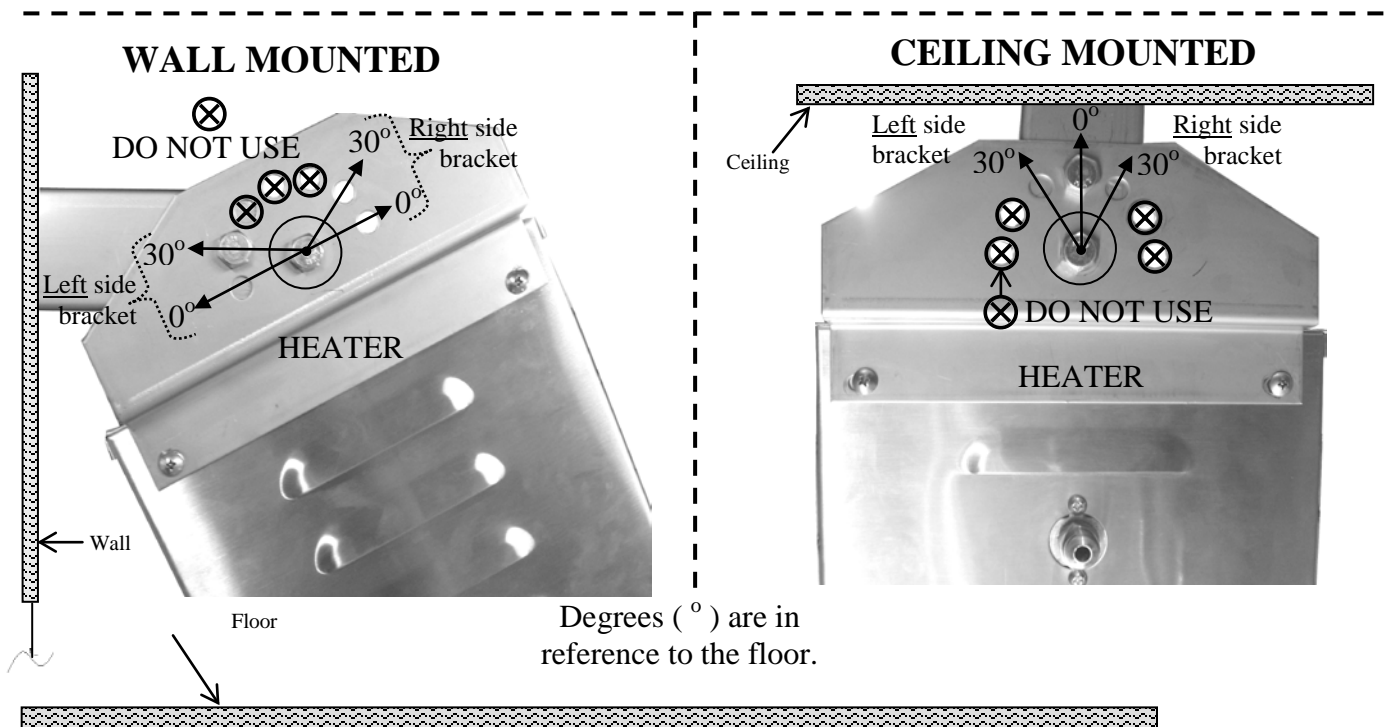

## 8. GAS INLET

- The gas inlet of the heater is located on the left side of the unit by design.
- The heater is NOT to be mounted to where the gas inlet is on the right side as it may cause damage to the heater and doing so will void the product warranty.

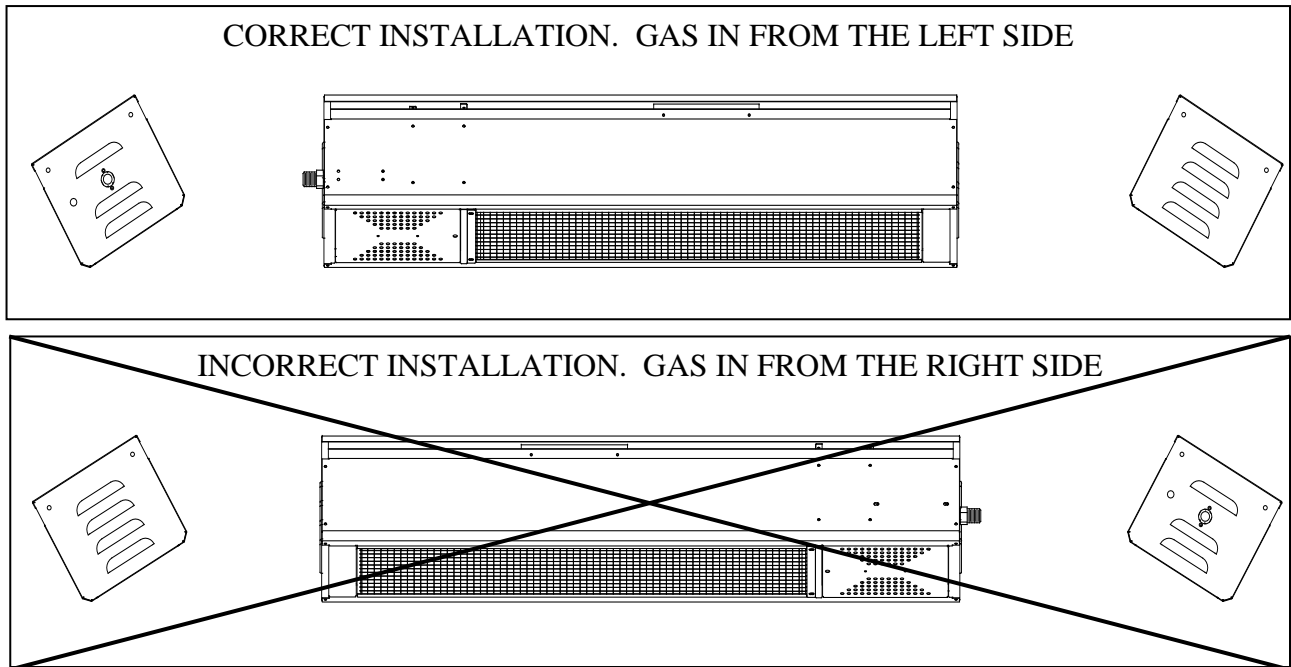

## 9. MOUNTING

- The heater may be mounted at a 0 degree angle or at a maximum of a 30 degree angle in reference to the floor. The heater must always be horizontal to the floor.
  - **WARNING:** If the heater is mounted at greater than a 30 degree angle will cause improper flue exhaust of combustion gases which may result in damage to the front grille.
- **NOTE:** Use only the mounting brackets provided by the manufacturer. Heater must be leveled only on a **Horizontal Axis** but can be angled to a maximum of 30 degrees in reference to the floor. **DO NOT** mount the heater on a vertical axis. Such installation is considered unsafe and improper and will automatically **VOID** the product's warranty.
- Clearance around the heater must be maintained for prevent fire hazard and to allow proper ventilation of the heater. Heater must be in a location that allows uniform air pressure around the entire heater.

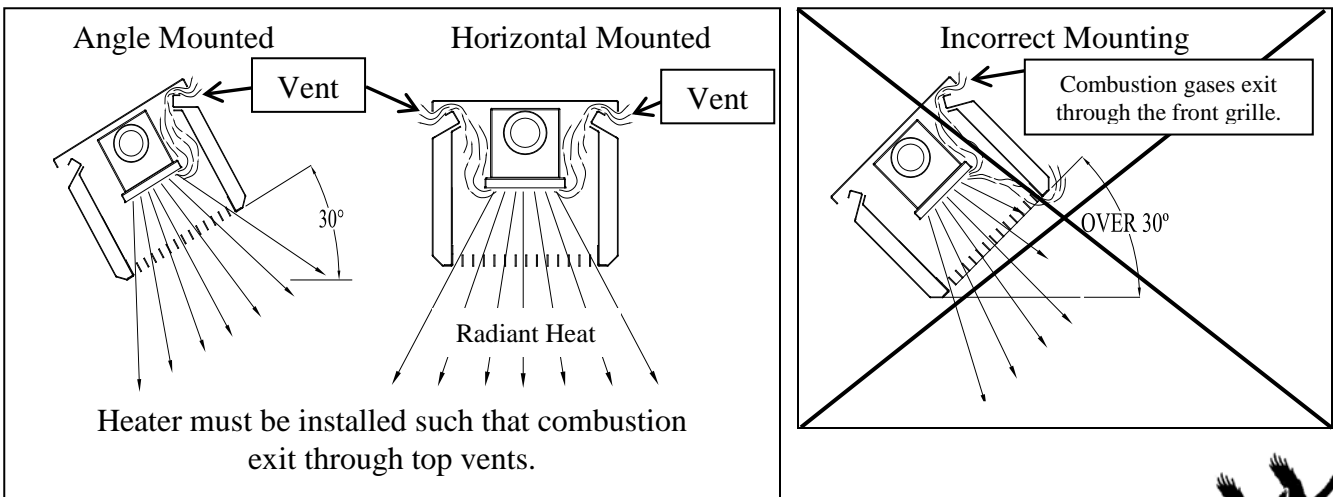

## MOUNTING CLEARANCES – GAS INFRARED HEATER

Each heater must be installed such that the following “Minimum Clearance to Combustibles” are maintained. Combustible materials include wood, compressed paper, plant fibers, plastic, or other materials capable of being ignited and burned. Such materials shall be considered combustible even though flame-proofed, fire retardant treated or plastered. Additional clearance may be required for glass, painted surfaces, vinyl siding or other materials which may be damaged by radiant or convection heat. •A minimum clearance of 24 inches above the heater must be maintained to plastics, vinyl or any other materials that may be adversely affected by radiant or convection heat.

**WARNING:** The clearances shown below are applicable to vehicles parked below or in front of the heater(s). They are also applicable to retractable awnings, umbrellas, pergolas, etc. whether the heater is ON or OFF. Do not place any objects whether combustible or non-combustible within the mounting clearances specified on the mounting instructions.

Note: Where applied, the Uniform Mechanical Code requires that all portions of overhead radiant heaters are located at least 8 feet above the floor.

### MINIMUM CLEARANCES to COMBUSTIBLES:

Sides or Ends	Back	Above	Below
<b>24”</b>	<b>12”</b>	<b>18”</b>	<b>48”</b>

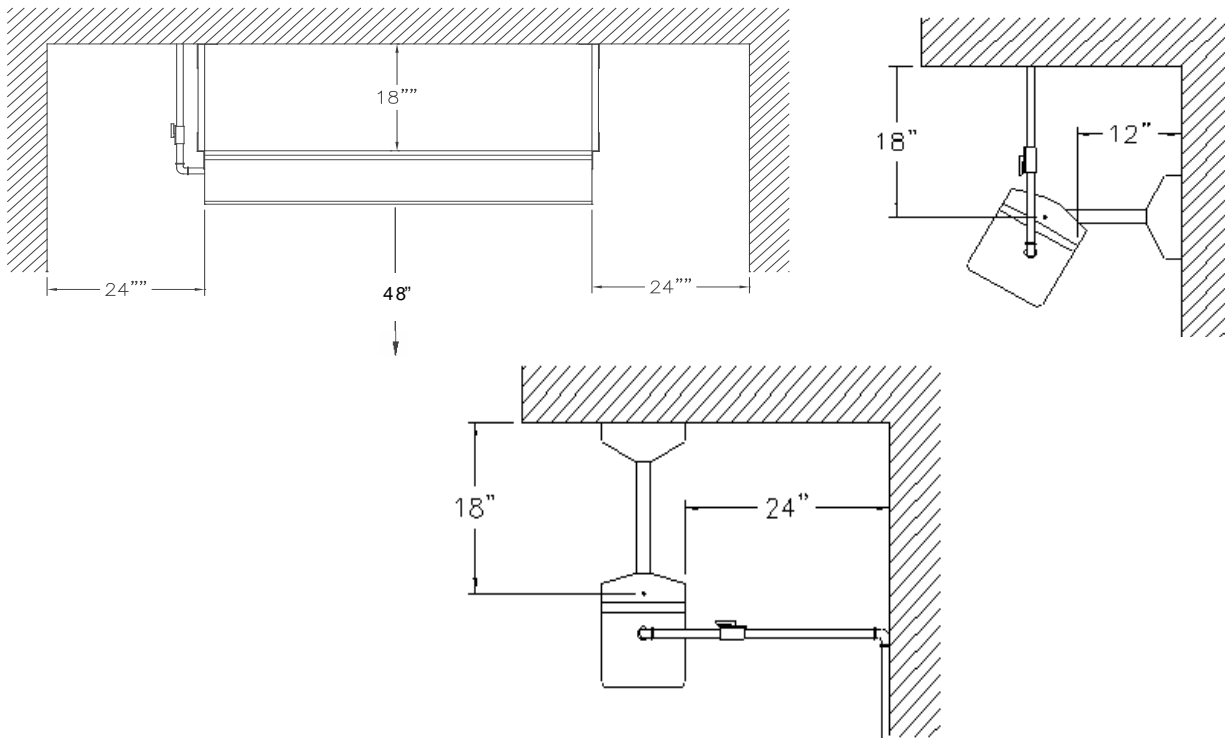

**NOTE:** Use only the mounting brackets provided by the manufacturer. Heater must be leveled only on a Horizontal Axis but can be angled to a maximum of 30 degrees in reference to the floor. **DO NOT** mount the heater on a vertical axis. Such installation is considered unsafe and improper and will automatically **VOID** the product's warranty.

\* Do not locate either the gas or electrical supply line directly above the flue outlet of the heater. The heater must be installed in a location so that it is readily accessible for servicing and have no restriction of airflow for combustion air and exhaust flue.

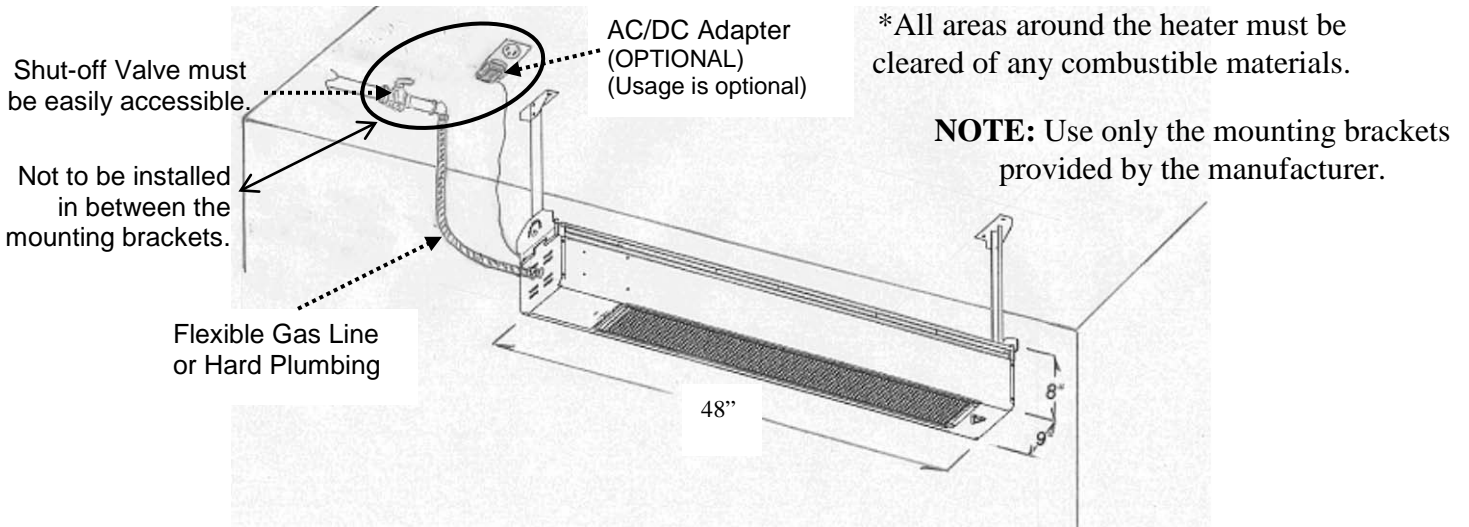

## ELECTRICAL INSTRUCTIONS – GAS INFRARED HEATER

5-1) To install the battery on the wireless remote control:

- a. Slide out the battery cover at the back of the remote control.
- b. Place the battery into the battery slot with the polarities pointing towards the appropriate polarity. Then push the battery in. Push the ON button to verify that the red indicator turns on. Then place the face plate back on with the Twin Eagles logo at the bottom near the LO button.



The receiver is powered by four 1.5V AA batteries located in a battery pack inside the heater component compartment. These batteries should be adequate for the heater operation for a whole season.

### 5-2) To install the AC Adaptor

An AC/DC volt adaptor can be used in which case the batteries will become a back-up voltage supply. The adaptor must NEVER be located inside the heater control compartment. If adaptor is used, provide a 120-volt outlet near the end of the heater but not directly above the heater.

- a. Run the power lead connectors of the AC adaptor through the small hole next to the gas inlet.
- b. Connect terminals of the adaptor to the “POWER” male terminals of the electronic controller, there is no polarity. Then plug in your adaptor to the 120V power outlet.

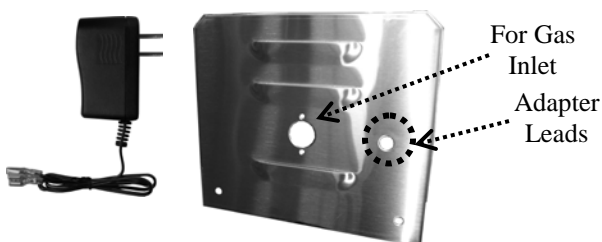

- c. The AA batteries go in the in the battery pack located inside the component compartment. When the adaptor is used the batteries will work as a back-up.

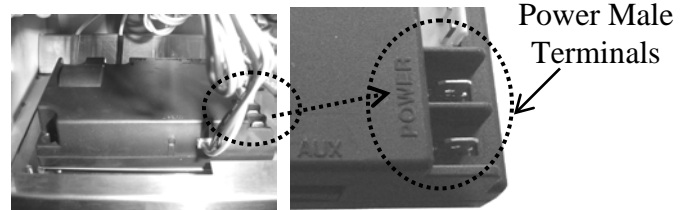

NOTE: Always have the battery pack switch on the “Latching Solenoid” side.

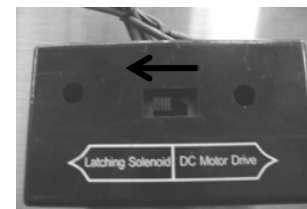

## OPERATING INSTRUCTIONS – GAS INFRARED HEATER

### A) INITIAL START-UP

1) Before you start your heater examine the heater installation to determine that:

- √ Areas immediately around heater including the air inlet and flue areas are free from obstructions.
- √ Physical support of the heater is safe, secure, adequate and sound.
- √ There is no obvious deterioration of the heater, gas inlet hose and AC adapter if used.

2) REMOTE CONTROL SYNCRONIZATION & START-UP TEST:

The remote control leaves the factory already synchronized for each heater. To verify that, with the heater's gas inlet valve in the CLOSED position, verify that the remote control system is working properly.

Push the "ON" button on the remote control. You will hear a continuous spark sound at the pilot. If there are no sparks, replace the AA batteries with new ones. If with the new batteries there are still no sparks, synchronization is needed. For synchronization perform the following steps.

#### Single heater application

- I. Push-and-hold the "LEARN" button on the module for 10 seconds until it "beeps" 3 times.
- II. Push-and-hold the ON button on the remote and the "beep" sound will confirm synchronization.

#### Multiple heater application

- I. Push-and-hold the "LEARN" button on the module for 10 seconds until it "beeps" 3 times and then remove a battery. Repeat same step for all heaters.
- II. Install the battery only to one heater.
- III. Push-and-hold the "LEARN" button until it "beeps" once and then push-and-hold the ON button on a remote control and the next "beep" sound will confirm synchronization.

**NOTE:** One remote control per heater.

- IV. Remove a battery to that same heater.
- V. Repeat steps II, III, IV and V for the rest of the heaters and its individual remote controls.
- VI. Once the synchronization is completed for all heaters place the battery back on all heaters.

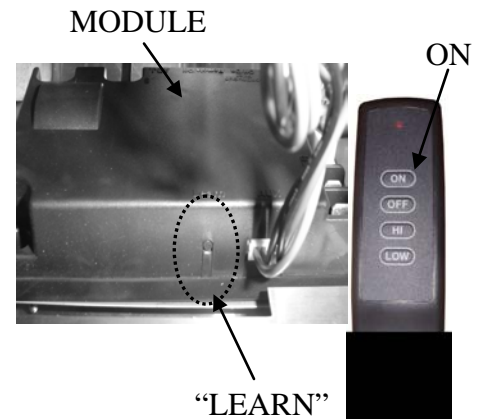



3. Check for gas leaks using soapy water at all gas connections and joint unions. NEVER use a flame to check for leaks
4. Pilot Burner Ignition Test
  - 4-1) Turn ON the gas supply to the heater.
  - 4-2) Please check the environment of the gas valve for a smell of gas. If for any reason you smell or think you smell gas, see the warning in the box below

**WHAT TO DO IF YOU SMELL GAS:**

- **Do not try to light any appliance.**
- **Do not touch any electric switch; do not use any phone in your building.**
- **Immediately call your gas supplier from a neighbor's phone. Follow the gas supplier's instructions.**
- **If you cannot reach your gas supplier, call the fire department.**

- 4-3) If you do not smell gas, locate the pilot burner of the heater which is mounted at the front end of the main burner. Make sure you have a line of sight to this pilot burner location.
- 4-4) Turn the gas heater **ON** by pressing the **ON** button on the remote control and press **HI**. For heaters that are wired to an external switch, flip the switch to the **ON** position
- 4-5) Allow the pilot burner and main burner to burn for about **10-15 seconds**.
- 4-6) Then turn the gas heater **OFF** and the pilot burner should shut off. It could take about **5 seconds** for the pilot flame to go completely OFF.
- 4-7) **CRITERIA:**
  - A) If the pilot burner shuts-off in about 5 seconds, the gas valve is working properly.
  - B) If the pilot burner continues to burn after the 5 seconds, please shut-off the main gas supply line to the heater. Then immediately contact your local distributor or dealer for a repair or replacement of the gas valve assembly

**NOTES:**

- **Some white smoke and green flame may appear during the initial start-up of the heater but it will dissipate with proceeding use.**

- **AUTO-LOCK OUT**

If the pilot continuously sparks for 60 seconds and the spark sensor doesn't sense a flame, it will go into safety AUTO LOCK OUT feature and shutoff the ignition system. Check that all heaters requirements have been applied. Then push the "OFF" button for 2 seconds to reset the system. Push the "ON" button again to light the pilot. If



the heater will not light after 3 attempts, shutoff the heater, shut-off the heater's manual gas inlet valve and call your qualified service agency

## **B. USING THE GAS HEATER:**

- 1) Always test the pilot burner ignition as per Step 4 above to insure that the gas valve is working properly.
- 2) Turn the main gas supply valve to the OPEN position.
- 3) Push the "HI" button, then push the "ON" button, you will hear clicking sounds and will see sparks to the igniter pilot. (Always start with HI setting during initial start-up
- 4) Once the pilot is lit, the pilot will ignite the infrared burner within 4 seconds. During ignition a smooth flame will roll down the length of the infrared burner. Flame should stabilize on the ceramic surface. Within 60 seconds the burner will start to glow bright and radiates heat

**CAUTION: The ceramics portion of the infrared burner should glow bright within 60 seconds and may be difficult to see in bright sunlight.**

**WARNING:** Never attempt to manually light the burner with a match or other source of flame. Twin Eagles heater utilizes an automatic lighting ignition.

### 5). HI – LOW SETTING

- a) Push the "HI" button and the heater will adjust the gas flow to 37,000 BTU/Hr.
- b) Push the "LO" button and the heater will adjust the gas flow to 25,000 BTU/Hr.

## **6. SHUTTING DOWN THE HEATER**

Push "OFF" on the remote control and verify that the pilot burner and the pilot have turned off. Should you need to shut down your heater for service or maintenance, the main gas valve next to the heater should also be turned "OFF".



## **PREVENTIVE MAINTENANCE – GAS INFRARED HEATER**

Routine maintenance should be performed at least once a year by a qualified service agency to insure the heater is operating properly. Overtime, particularly during long periods of not being used, the heater can accumulate dirt, debris and cobwebs in and around the pilot and the burner. More frequent service may be required for heaters located near waterfronts or in strong wind areas where there might be sand storms.

It is strongly recommended that the heaters be inspected annually, before each use season.

### **STAINLESS STEEL**

The heater is made of non-rusting stainless steel. Certain areas may discolor overtime. This is a normal discoloration caused by the intense heat given off by the burners. Use the mildest cleaner and always scrub in the direction of the grain. Do not use steel wool to clean the surface. Never clean the heater when it's hot.

### **LEAK TEST**

At the beginning of each fall/winter season and after filling and reattaching the propane tank, you should test the unit for gas leaks using soap solution. Periodically inspect the connections for corrosion. If you find a problem, contact your gas supplier for repairs.

### **SPIDER AND INSECT WARNING**

Spiders and other insects can nest in the burner which can cause the gas to flow from the front of the burner. This dangerous "condition" can cause a fire behind the valve panel, damaging the heater and making it unsafe to operate. Inspect the burner once a year or if the heater has not been used for more than one month.

### **ELECTRICAL SHOCK HAZARD**

Disconnect electrical power and gas supply before servicing. This heater must be connected to a properly grounded electrical source.



## TROUBLESHOOTING GUIDE – GAS INFRARED HEATER

**NEVER attempt to service the heater without disconnecting or shutting OFF its power and gas supply from the source.**

Important Notes:

- a) After the initial usage it is normal to see white smoke come out the back. This eventually will go away and it doesn't affect the performance of the heater.
- b) It is also normal to see warpage on the housing since the housing expands while heated but after it cools back down it will come back to its originally shape because the housing is a welded construction.
- c) On LP (propane) gas heaters, NEVER use a DENTED, RUSTED LP tank or with a DAMAGED valve.

PROBLEM	WHAT TO DO
Igniter sparks but pilot burner will not ignite and igniter goes to lock-out.	<ol style="list-style-type: none"> <li>1. No gas supply to the pilot . Check if gas supply valve is turned on.</li> <li>2. Air trapped in gas line (VERY COMMON DURING INITIAL START-UP). Turn on remote control 3 times to purge air. If unsuccessful, disconnect gas hose from heater inlet and purge air until you smell gas. Then reconnect gas hose to heater inlet.</li> </ol>
Igniter gives very weak or slow sparks.	<ol style="list-style-type: none"> <li>1. Low battery in battery pack. Open heater control panel and replace 4 AA batteries.</li> <li>2. Ground wire is not connected. With the control panel open, check if green wire is grounded.</li> </ol>
Remote control (transmitter) will not communicate with heater module (receiver)	<ol style="list-style-type: none"> <li>1. Low battery in transmitter. Replace 2 lithium batteries (3V)</li> <li>2. Low battery in battery pack or battery pack is unplug. Open control panel and check if battery pack is plugged in or replace 4 AA batteries.</li> <li>3. Module switch is set to OFF. Make sure module switch is set to REMOTE.</li> <li>4. Remote is not synchronized with module. Refer to manual on how to synchronize remote.</li> </ol>
Remote control communicates with heater but heater will beep and no sparks to pilot.	<ol style="list-style-type: none"> <li>1. Pilot sensor is damped or wet. Installation must be located in dry condition.</li> <li>2. Defective pilot sensor. Replace pilot burner assembly</li> <li>3. Low battery pack. Replace 4 AA batteries.</li> </ol>
Pilot turns on and off. Burner turns on and off	<ol style="list-style-type: none"> <li>1. Windy condition. Pilot sensor senses flame inconsistently. Do not operate equipment until wind dies down or heater is relocated to less windy condition.</li> <li>2. Pilot flame is too small for flame sensing. Increase pilot flame such that flame surrounds the pilot sensor rod.</li> <li>3. Heater is installed reversed such that the pilot sensor is below the pilot flame instead of above or even to the pilot flame. Correct installation such that the gas inlet is on the left side of the heater for proper operation. When the gas inlet is on the left side the pilot sensor rod is above the pilot burner.</li> </ol>
Pilot burner stays on after heater is turned off.	<ol style="list-style-type: none"> <li>1. Defective gas valve. Contact local dealer to replace gas valve.</li> </ol>



Heater valve will not switch from Hi to Low and vice versa	<ol style="list-style-type: none"> <li>1. Low battery pack. Replace 4 AA batteries.</li> <li>2. Ground wire not connected. Connect ground wire to chassis and remove and re install 4 AA batteries to clear memory.</li> <li>3. Defective gas valve. Contact local dealer to replace gas valve.</li> </ol>
Batteries in the battery pack drain fast.	<ol style="list-style-type: none"> <li>1. The battery pack is switch to DC MOTOR instead of LATCHING SOLENOID. Make sure that the battery pack switch is set to LATCHING SOLENOID.</li> </ol>
Front grille deteriorates	<ol style="list-style-type: none"> <li>1. Tip angle exceeding 30 degrees such that products of combustions vent out to the front grille instead of out the top of the heater. Correct installation and make sure only radiant heat passes through the front grille.</li> <li>2. Windy condition. Excessive wind disrupts flow of combustion products such that combustion products flow though the front grille instead of out the top of the heater. Locate heater in less windy conditions.</li> </ol>
Burner makes loud rumbling noise during operation. Burner does not glow and flares out.	<ol style="list-style-type: none"> <li>1. Damaged burner. Contact local dealer to replace burner.</li> </ol>
Heater operates but makes continuous beeps.	<ol style="list-style-type: none"> <li>1. Module exceeds designed operating temperature. Improper installation such that products of combustion flows through the front grille instead of out the top of heater. This could be due to exceeding the 30 degree tip angle or windy conditions. Correct installation such that only radiant heat passes through the front grille.</li> </ol>



## REPLACEMENT PARTS LIST – GAS INFRARED HEATER

Item Number	Part Number	Part Description	Qty
1	15325	Gas Hose	1
2	16174	A/C 120V to 6V adapter (OPTIONAL)	1
3	16175	Wireless Remote Control	1
4	21922	Plate Brackets	2
5	21923	Arm Brackets	2
6	21924	Wall Mount Brackets	2
7	13343	Infrared Burner	1
8	16173	Battery pack (NOT SHOWN)	1
9	16172	Wire Harness, (NOT SHOWN)	1
10	15108-36	Orifice 36 Natural Gas (NOT SHOWN)	1
11	15108-50	Orifice 50 LP Gas (NOT SHOWN)	1
12a	13112	TWIN EAGLES Logo	1
12b	13147	TWIN EAGLES Emblem	1
13a	13850Ya	Heat Diffuser (TEGH48)	1
13b	13850Yb	Heat Diffuser (TEGH60)	1
14a	21907	Door, Component Compartment (TEGH48)	1
14b	21942	Door, Component Compartment (TEGH60)	
15	16171	Receiver, Control Module (NOT SHOWN)	1
16	15113	2 Stage Gas Valve (NOT SHOWN)	1
17	13348	Orifice, Pilot 0.012 LP (NOT SHOWN)	1
18	13349	Orifice, Pilot 0.018 NG (NOT SHOWN)	1
19	13347	Pilot Burner (NOT SHOWN)	1
20	12654	Coupling, $\frac{3}{8}$ " NPT x $\frac{3}{8}$ " M-flare (NOT SHOWN)	1

For ordering parts, contact Twin Eagles, Inc., Toll free No. 1(800) 789-2206.

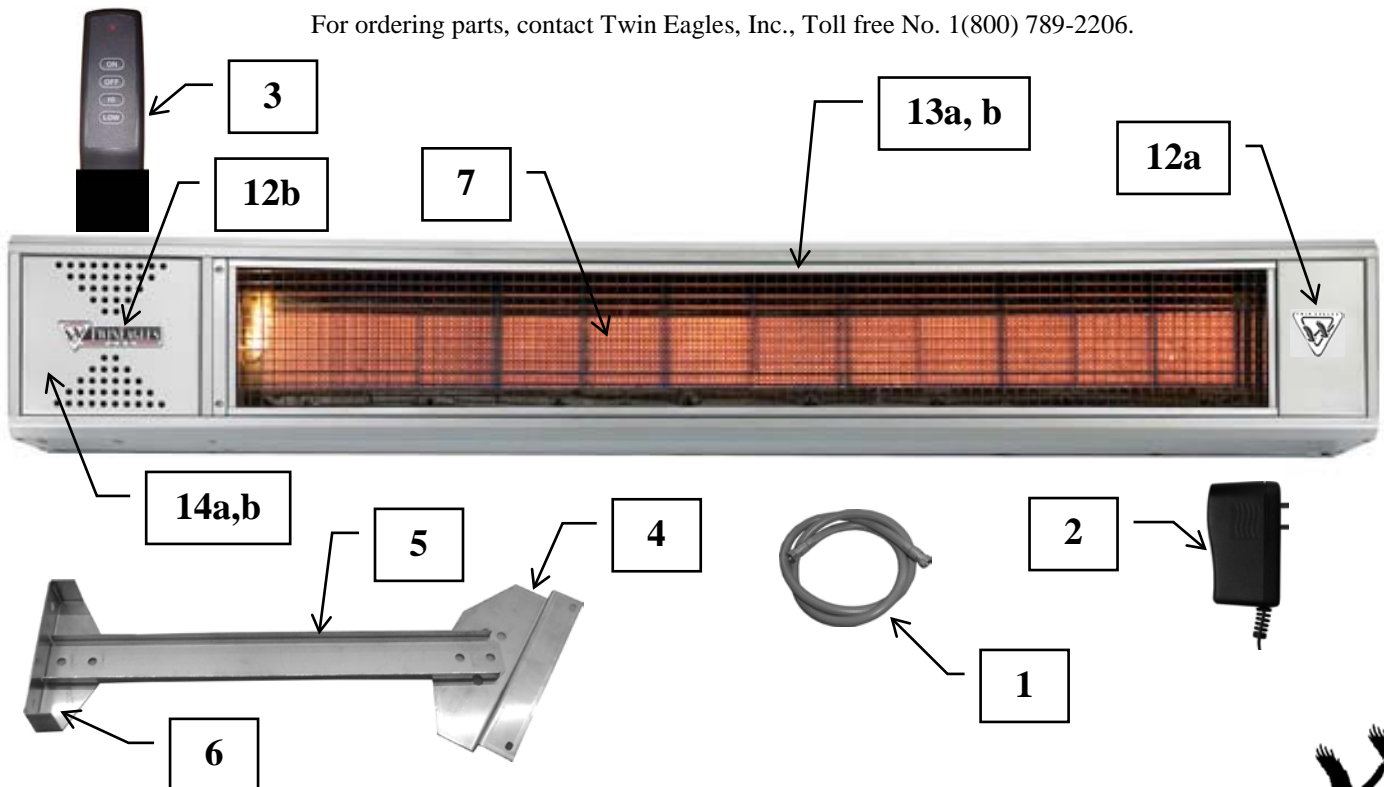

# TWIN EAGLES OUTDOOR GAS INFRARED HEATER

## Limited Product Warranty

**ONE-YEAR RESIDENTIAL WARRANTY:** Twin Eagles warrants the outdoor gas heater to be free from defects in materials and workmanship under normal single family residential use for a period of one year from the original date of purchase. This warranty excludes discoloration, surface scratches, weather and atmospheric related staining, and minor surface rust and oxidation which are normal conditions and to be expected with any outdoor product. The actual part will be repaired or replaced, free of charge, with the owner paying for all other costs including labor and freight.

**NINETY (90) DAY COMMERCIAL WARRANTY:** This warranty applies to commercial applications where use of the product extends beyond normal residential use such as apartments, restaurants and food service locations. The actual part will be repaired or replaced, free of charge, with the owner paying for all other costs including labor and freight.

### **WARRANTY LIMITATIONS & EXCLUSIONS**

- This warranty shall apply only to the products purchased and located in the continental United States and Canada. The warranty coverage begins on the original date of purchase and proof of date of purchase is required. In order to activate the warranty, we require that you send in the attached warranty registration card. This warranty applies only to the original owner and may not be transferred.
- This warranty does not apply to gas heaters that are NOT protected from rain, ocean spray, moisture and strong wind.
- This warranty does not apply to damages resulting from negligence, alteration, misuse, abuse, accident, natural disaster, loss of electrical power to the product for any reason, improper installation or improper operation, unauthorized adjustments or calibrations, dings, dents, scratches, or damages due to harsh cleaning chemicals.
- This warranty does not apply to products with altered or removed serial numbers.
- Twin Eagles shall not be liable for incidental, consequential, special or contingent damages resulting from its breach of this written warranty or any implied warranty.

**WARRANTY SERVICE & REPLACEMENT PARTS:** In most cases, your dealer or sales representative will handle the warranty service for you. Call your authorized selling dealer or call Twin Eagles directly at 800-789-2206. Be prepared to furnish the following information: Purchaser's name, model and serial number of the heater, date of purchase and the accurate description of the problem. Twin Eagles will not pay for service calls for correcting an installation problem. Owner shall be responsible for proper installation, providing normal care and maintenance, providing proof of purchase upon request and making the heater accessible for service. In the event of any warranty replacement, all removal, replacement, installation and shipping costs are the responsibility of the heater owner.

**LIMITATION ON IMPLIED WARRANTIES:** Some states do not allow limitations on how long an implied warranty lasts, so the above limitations may not apply to you.



Place  
Postage  
Here



Cut  
Here

Customer Service  
ATTN: Warranty Department  
13231 East 166<sup>th</sup> Street  
Cerritos, CA 90703  
Fax no. (562) 802-3391

Fold Here



## Warranty Registration

Customer Name	Model #
Address	Serial #
City	Date Purchased
Zip	Dealer's Name
Phone #	Dealer's Address
e-mail:	

This Warranty Registration card must be returned within thirty days of purchased to properly activate your warranty.

This information is for our internal use only.