

This Owner's Manual is provided and hosted by [Appliance Factory Parts](http://www.appliancefactoryparts.com).



PANASONIC SR-PRA18N Owner's Manual

[Shop genuine replacement parts for PANASONIC
SR-PRA18N](#)



[Find Your PANASONIC Small Appliance Parts - Select From 148 Models](#)

----- Manual continues below -----



Electronic Pressure Rice Cooker/Warmer
전기압력보온밥솥
圧力ジャー炊飯器



Operating Instructions

사용설명서 取扱説明書

SR-PRA18N(1.8L)

●Thank you very much for purchasing **National** Electronic Pressure Rice Cooker/Warmer. Read all instructions before use. Save these instructions for future reference.

●이번에 **National** 전기압력밥솥을 구매하여 주셔서 대단히 감사하는 바입니다.

이설명서를 잘 읽으시고 정확하게 사용하십시오. 그 후 소중하게 보관하시어 필요할 때에 읽어 주시기를 바랍니다.

●この度はナショナル圧力ジャー炊飯器をお買い上げいただきまことにありがとうございました。

本説明書をよくお読みのうえ、正しくお使いください。そのあと大切に保存し、必要なときにお読みください。

Contents

- Important1
Safeguards
- Precautions4
- Description of9
Each Part
- Time Adjustment11
- Preparation for11
Cooking Rice
- How to Cook12
- Keeping Rice13
Warm
- Reheating13
- Timer Cooking14
- Cleaning and15
Maintenance
- Troubleshooting16
- Specifications19

차례

- 안전상 주의..... 20
- 각부의 설명..... 25
- 시간 맞추기..... 27
- 취사 준비..... 27
- 밥을 짓는 방법..... 28
- 보온..... 29
- 재가열 29
- 예약 취사..... 32
- 손질의 방법 31
- 고장인가?..... 32
- 사양..... 35

もくじ

- 安全上のご注意..... 36
- 各部の説明 41
- 時刻合わせ..... 43
- 炊飯準備..... 43
- ごはんの炊き方 44
- 保温 45
- 再加熱 45
- 予約炊飯 46
- お手入れのしかた 47
- 故障かな!? 48
- 仕様 51

IMPORTANT SAFEGUARDS

1. Read all instructions before using this appliance.
2. Do not touch hot surfaces. Use handles or knobs.
3. To protect against fire, electric shock and/or injury to persons do not immerse cord, plugs, or Pressure Cooker Body in water or any other liquid.
4. Close supervision is needed when this appliance is used by or near children.
5. Unplug from outlet when not in use and before cleaning. Allow to cool before putting on or taking off parts, and before cleaning the appliance.
6. Do not operate any appliance with a damaged cord or plug or after the appliance malfunctions, or has been damaged in any manner. Return the appliance to the nearest authorized service facility for examination, repair or adjustment.
7. The use of accessory attachments not recommended by the appliance manufacturer may result in fire, electric shock, and/or injury to persons.
8. Do not use outdoors.
9. Do not let the cord hang over the edge of the table or counter, or touch hot surfaces.
10. Do not place on or near a hot gas or electric burner, or in a heated oven.
11. Do not use this appliance for other than its intended use.
12. Extreme caution must be used when moving an appliance containing hot oil or any hot liquids.
13. Oversized foods, metal foil packages, or utensils must not be inserted in the appliance as they may involve a risk of fire or electric shock.
14. A fire may occur if the appliance is covered or is touching flammable material, including curtains, draperies, walls, and the like, while in operation.
15. To reduce the risk of electric shock, cook only in removable container.
16. This appliance cooks under pressure. Improper use may result in scalding injury. Make certain unit is properly closed before operating. See "Operating Instructions."
17. Do not cook foods such as applesauce, cranberries, pearl barley, oatmeal or other cereals, split peas, noodles, macaroni, rhubarb, or spaghetti. These foods tend to foam, froth, and splatter, and may block the pressure release device.
18. Always check the pressure release device for clogging before use.
19. Do not open the pressure cooker until the unit has cooled and internal pressure has been reduced. See "Operating Instructions."
20. Do not use this pressure cooker for pressure frying with oil.
21. SAVE THESE INSTRUCTIONS.

**SAVE THESE INSTRUCTIONS
THIS APPLIANCE IS FOR HOUSEHOLD USE ONLY**

ADDITIONAL IMPORTANT SAFEGUARDS

WARNING : *This appliance generates heat and escaping steam during use. Use proper precaution to prevent risk of burns, fires, or other injury to persons or damage to property.*

1. Keep hands and face away from Pressure Controller when releasing pressure.
2. Use extreme caution when opening the lid after cooking.
 Serious burns can result from steam inside.
3. Never open the Lid while the unit is in operation.
4. Do not use without the inner Pot in place.
5. Do not cover the Pressure Emission Valve with anything as an explosion may occur.
6. Do not touch the inner Pot, any inner parts or heating parts immediately after using. Let the unit cool completely first.

NOTE

- A. A short power-supply cord(or cord set) is provided to reduce the hazards resulting from becoming entangled in or tripping over a longer cord.
- B. Longer cord set or extension cords are available and may be used if care is exercised in their use.
- C. If a long cord set or extension cord is used,
 - (1) the marked electrical rating of the cord set or extension cord should be at least as great as the electrical rating of the appliance.
 - (2) if the appliance is of the grounded type, the extension cord should be a grounding-type three-wire cord, and
 - (3) the longer cord should be arranged so that it will not drape over the countertop or tabletop where it can be pulled on by children or tripped over accidentally.

This appliance has a polarized plug : (one blade is wider than the other).

As a safety feature, this plug will fit in a polarized outlet only one way.

If the plug does not fit fully in the outlet, reverse the plug.

If it still does not fit, contact a qualified electrician.

Do not attempt to defeat this safety feature.

Precaution

Warning

The following must be observed to prevent you from injury or property damage.

• Different marks indicate the degrees of injury or property damage as follows.



Warning

This symbol indicates information that, if not heeded, could possibly result in loss of life or serious injury.



Caution

This symbol indicates information that, if not heeded, could result in injury or property damage.



Warning

- **Do not insert metal objects such as pins and needles, or any other foreign objects into the air intake, exhaust outlet, or any other portion of the unit.**

- May result in irregular operation and injury.

- **Do not let children or those who are unfamiliar with the operation operate the rice cooker. Keep the rice cooker out of the reach of children.**

- Children may receive burns or electric shock.

- **Do not plug or unplug the rice cooker with wet hands.**

- May result in electrical shock.

- **Do not attempt to modify, disassemble or repair the unit.**

- May result in fire, electrical shock, or injury.
- Consult your nearest sales representative or service center for repair.

- **Do not damage the power cord or the power plug.**

(Avoid damage to the power cord. Do not attempt to modify the power cord. Keep the power cord away from high temperatures. Avoid unnecessary bending, twisting and pulling of the power cord. Do not attempt to tie the power cord in a bundle. Do not place any heavy things or the power cord.)

Using a damaged power cord may result in electrical shock, shorting, or fire.

- If the power cord or the power plug is damaged, consult your nearest sales representative or service center for repair.

- **Do not immerse the unit in water or exposed it to water**

- May result in shorting or electrical shock.
- When water enters the main unit, consult your nearest sales representative or service center.

- **Ensure that the plug fits fully into the electrical outlet. Do not leave prongs**

- Failing to insert the plug fully may cause electrical shock or fire due to overheating.



Warning

■ **Use an outlet with at least a 15A rating and 120V. Using with other appliances may fire.**

- When using an extension cord, be sure to use a cord with at least 15A rating.

■ **Remove dust from the power plug periodically.**

- Excessive dust on the plug may reduce insulation due to humidity, etc., resulting in fire.

■ **Do not place things on the pressure controller and the pressure release vent.**

- May cause explosion by pressure.

■ **Do not force the locking handle**

- May result in explosion if it is forced.
- Confirm complete steam emission before turning the locking handle.

■ **Do not open the lid during operation.**

- The lid may not be opened during operation. Forcing the lid open, may result in burns.
- If you have to open it, press the "Cancel" key, then push the pressure controller to release the internal pressure and confirm complete steam emission before opening.

■ **Do not place your hand or face over or near the pressure controller and the pressure emission vent during operation. KEEP OUT OF REACH OF CHILDREN.**

Precaution



Caution

■ **Do not use the unit in wet locations or high temperatures.**

- May cause electrical shock, electrical leaks, or fire.

■ **Be sure to hold onto the power plug when rewinding it to avoid electrical shock, electrical leaks, or fire.**

- May receive burns.

■ **Do not place the unit on a bumpy or a slanted place.**

- May result in fire or injury due to tipping

■ **Place the indicator of the locking handle to “LOCK” position even if unplugged.**

- Always turn the locking handle to “LOCK” position while using.
- Deformation or damage may result if a hot inner pan is in the unit and locking handle is turned to the “UNLOCK” position.

■ **Do not use deformed inner pan or one not specified for the unit.**

- May result in unit malfunction and fire by overheated inner pan.

■ **Do not put more than specified maximum quantity for the item being cooked, for example, 10 cups of white rice.**

- May cause unit to malfunction by overboiling or stuciaing steaming vent.
- For chicken & Herb Soup, do not use more than the specified quantity.

■ **Do not use the unit for other than its intended use.**

- May damage the unit and cause an odor.

■ **Keep hands and face away from the unit while it automatically releases the steam before finishing.**

- May result in burns.
- Steam may come out with a hissing sound.

Keep out of reach of children.

■ **Do not touch the metal part on the inside of the lid during or just after use.**

- May receive burns.

■ **Do not put a magnetic object on the lid or place the unit near a strong magnetic object.**

- May result in breakdown or abnormal operation.

Precaution



Caution

■ **Do not drop the unit or hit it.**

- May result in damage to the unit or safety problems.

■ **Clean the unit when the unit is cold to prevent being burnt.**

■ **Do not use the inner pan and damage to the coating.**

- May result in beformation of the Inner pan and damage to the coating.

■ **Do not use the rice cooker near walls or furniture. Possibility of warping of sections which come in contact with steam.**

- When using the rice cooker in a cabinet, etc., make sure that steam does not collect.



NOTE FOR USE

■ **Keep the outside of inner pan and the inner pan sensor clean and dry.**

- Any foreign substance may cause the unit to malfunction.

■ **Never use the rice cooker in strong sunlight.**

■ **Do not put any cover, cloth, etc., on the lid.**

- May result in discoloration and deformation of the body.

To avoid damage to the non-stick coating on the cooking pan:

■ **Avoid tapping or scratching the pan.**



■ **Do not put spoons or other utensils in the pan.**



■ **Do not attempt to clean the pan with scouring powder, steel wool, or a nylon scouring pad.**

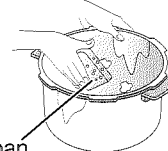

Clean the pan with a sponge.

■ **Do not use vinegar.**

■ **Wash the pan immediately after cooking with any seasoning.**

■ **Do not attempt to wash rice with a whisk.**

■ **When using a metal tablespoon, be careful not to damage the coating.**

Parts Identification

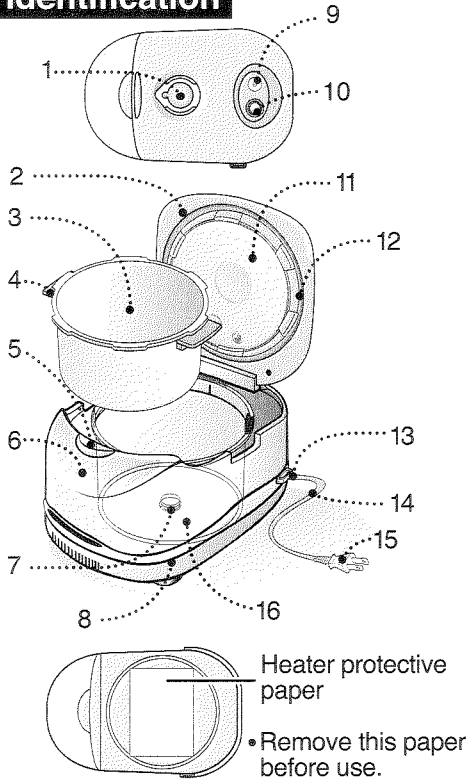

Accessories

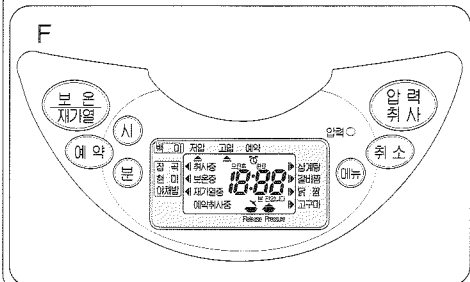
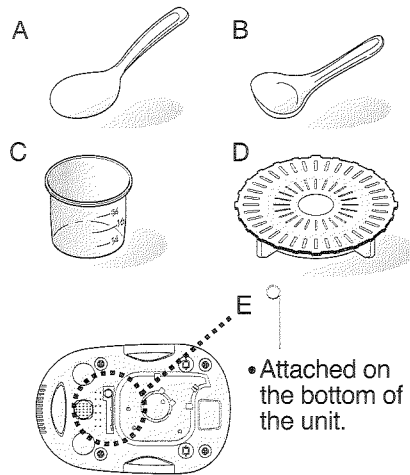

Control Panel

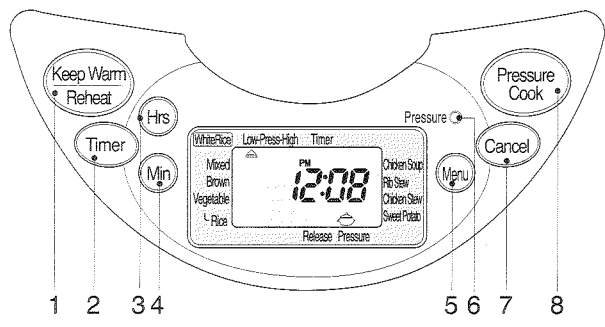

LCD/Menu

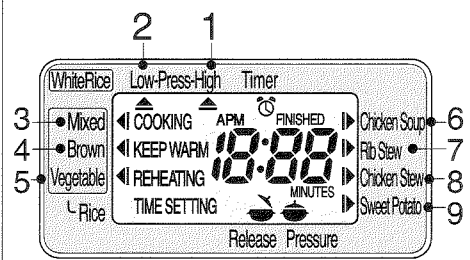

Water level

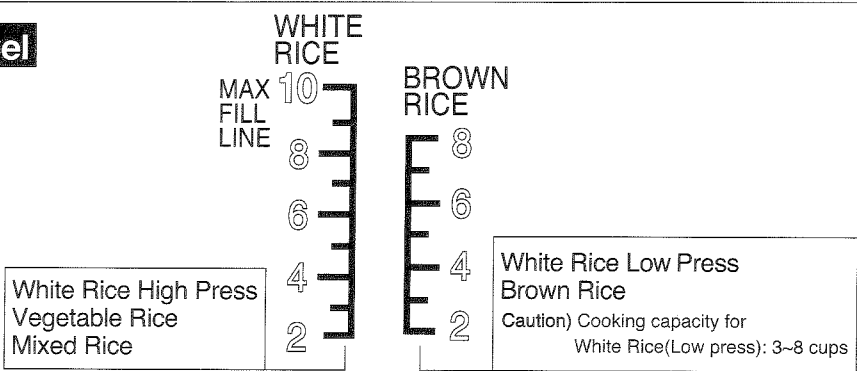

Description of Each Part

Parts Identification

1	Locking handle	7	Temperature sensor	12	Packing
2	Lid	8	Body	13	Scoop holder
3	Inner pan	9	Steam emission vent	14	Power cord
4	Inner pan handle	10	Pressure controller	15	Power plug
5	Hook button	11	Inner Pan cover	16	Heating plate
6	Control panel / LCD				

Accessories

A	Rice scoop
B	Soup scoop
C	Measuring cup
D	Steam plate
E	Cleaning pin
F	Panel seal(Korean)

Control Panel

1	Keep Warm/Reheat	Turns on the keep warm function. Turns on the reheat function.
2	Timer	Sets the timer.
3	Hrs	Adjust hours. Sets hours for timer cooking or Current time.
4	Min	Adjust minutes. Sets minutes for timer cooking or current time.
5	Menu	Selects a cooking menu.
6	Pressure Lamp	Light turns on when the locking handle is turned to LOCK.
7	Cancel	Cancel menu selection or releases steam.
8	Pressure Cook	Starts cooking.

LCD

Displays a selected cooking menu, the current time and finish-up time.

Menu

1	White rice-High Press	Makes white rice glutinous
2	Low Press	Makes white rice glutinous-more than general rice cooker but less than high pressure
3	White rice-Low Press	Cooks mixed rice
4	Mixed	Cooks brown rice
5	Brown Rice	Cooks vegetable rice
6	Vegetable	Cooks chicken soup
7	Chicken Soup	Cooks rib stew
8	Rib Stew	Cooks chicken stew
9	Chicken Stew	Steams sweet potato using the included steaming plate

Water level

Adjust amount of water as marked in the inner pan according to the menu.

Time adjustment

1

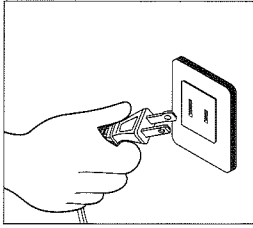

2

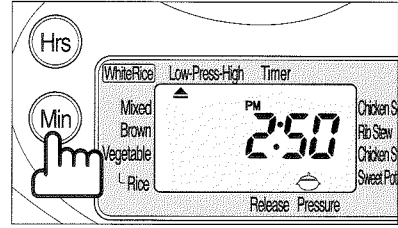
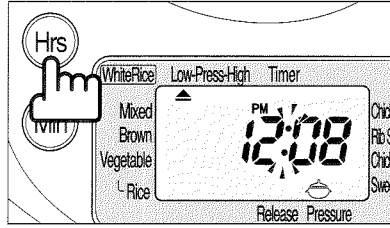

Preparation for Cooking

1

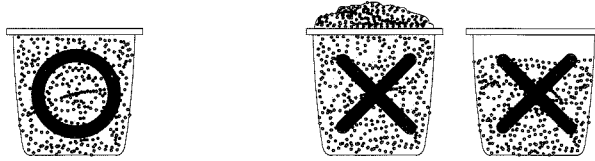

2

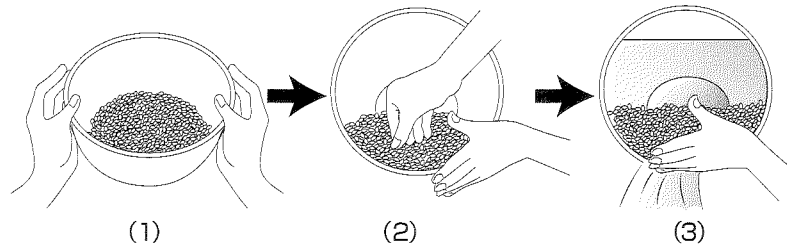

3

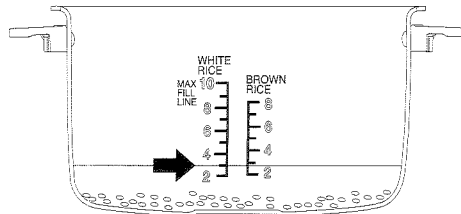

4

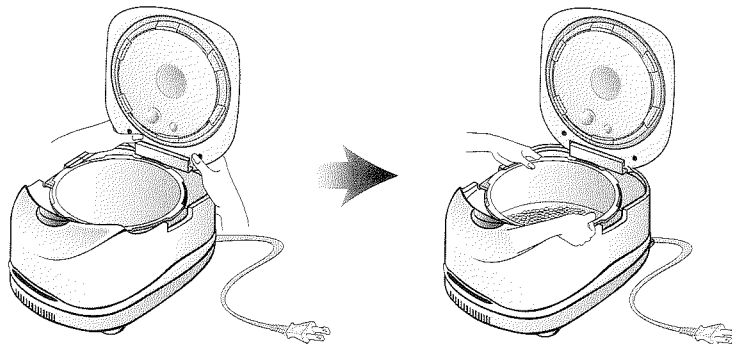

Time Adjustment

If the clock of the rice cooker is not set correctly, the food will not be done at the desired time when the timer function is used.

Set the clock to the current time.

- 1 Plug the rice cooker into an electrical outlet. Press either the “Hrs” key or the “Min” key for one second or longer until the time indication starts flashing.**
- 2 Adjust hours by pressing the “Hrs” key. Each push of the “Hrs” key advances hours one by one and holding the “Hrs” key down advances hours continuously. Similarly, adjust minutes by pressing the “Min” key**

In about seven seconds, the time indication will stop flashing and the time is set.

Preparation for Cooking Rice

The minimum and maximum amount of rice that can be cooked will vary depending on the menu chosen.

Refer to the table below.

Menu		Cooking capacity(cups)	Menu	Cooking capacity(cups)	Menu	Cooking capacity(cups)
White Rice	High Press	2~10	Mixed rice	2~8	Brown rice	2~8
	Low Press	3~8	Vegetable rice	2~8		

- 1 Measure rice. (Use the measuring cup (approx. 180ml) provided)**
- 2 Rinse rice.(Rinse rice in a container other than the rice cooker inner pan)**

(1) Rinse rice quickly in a lot of water, then quickly drain.

(2) Rinse rice evenly and quickly so that rice grains rub each other.

(3) Rinse rice with a lot of water, then drain,

Repeat steps(2) and (3). until water runs clear

Note : Rinse rice thoroughly. Otherwise, rice may scorch or smell like bran.

Caution) Do not add water more than necessary for the amount of rice being cooked. Hot liquid coming out from the steam vent may cause burn.

- 3 Add water.**

Put the rinsed rice into the inner pan and add water to the appropriate water level depending on the amount of rice and the menu chosen. (The figure shows the water level for cooking three cups of white rice (Low press).) To measure the water level correctly. Place the inner pan on a flat surface and check the water level against the gauges at both sides of the inner pan.

- 4 Put the inner pan into the unit.**

Make sure outside of the inner pan, heating plate, and pan sensor are clean and dry.

Place the inner pan into the unit.

Make sure the handle of the inner pan is in proper position.

※When the inner pan in improper position, the lid can not be closed.

- 5 Close the lid.**

Plug the unit into an electrical outlet and turn the locking handle to “LOCK”

Please check that the pressure controller is placed correctly.

(For method of attachment; Refer to page 15.)

•Pressure lamp will turn on when the lid is closed correctly.

•E01 is displayed if you Press “Pressure Cook” key when the lid is closed improperly.

•Do not close the lid with force. May damage the unit.

How To Cook

- ▶ Turn the locking handle to "LOCK".
- ▶ Set the pressure controller horizontally before starting to cook.

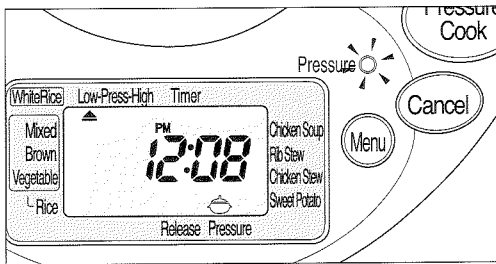

1. Press "Menu" key to select menu.

- ▶ Each pressing of the "Menu" key moves ◀(or ▲) from one menu to another as follows.
 "White Rice(High press)"→"White Rice (Low press)"→"Mixed"→"Brown Rice"→"Vegetable"→"Chicken Soup"→"Rib Stew"→"Sweet Potato"
 (The figure shows the indication on the LCD when the "Low press" for white rice menu is selected.)
 The menus such as "White Rice(High press)", "White Rice(Low press)", "Mixed", "Brown Rice" are memorized once the functions are used.
- ▶ Note: In case of cooking white rice, Mixed and Brown rice, when the unit is plugged in, the most recently used menu will be indicated.

2. Press "Pressure Cook" key to start.

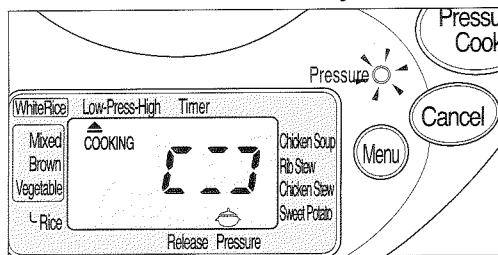

- ▶ Do not press "Cancel" Key. It stops cooking.
- ▶ The LCD displays the remaining time to finish cooking from steam process. Time may vary depending on the menu.

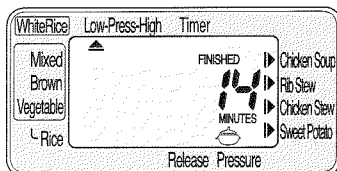

■ Standard cooking time
(Approx. in minutes)

Manu		Standard cooking time (Approx. in minutes)
White	High Press	27 to 38
Rice	Low Press	29 to 41
Mixed Rice		40 to 47
Brown Rice		49 to 58
Vegetable		37 to 45
Chicken Soup		57
Rib Stew		41(1.2kg)
Chicken Stew		42(1.5kg)(3.3lbs)
Sweet Potato		31(5ea)

- ▶ Slice sweet potato into pieces if it's over 150g (5.25oz).

• The steam is released automatically 3 minutes before the steam process is finished.

(When cooking white Rice(Low Press), steam is released twice automatically 12 minutes before the steam process is finished.

- When cooking is finished, the cooker sounds a beep and LCD turns from "COOKING" to "KEEP WARM".

3. Turn the locking handle to "UNLOCK" and press the hook button to open the lid. Mix rice completely within 30 minutes after cooking is finished.

- If the lid doesn't open right after cooking is done or during the keep warm process because of the internal pressure, tilt the pressure controller to the side to release the pressure completely.

Keeping Warm / Reheating

Warm

When cooking is finished, the unit automatically switches to the "KEEP WARM" mode.

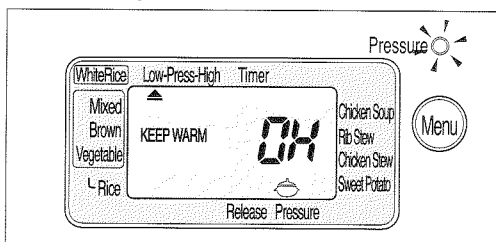

Caution while keeping warm

- 1) Do not use the keep warm function for brown rice, or mixed rice to prevent brown rice and mixed rice from releasing odors or becoming discolored, or from becoming gluey.
- 2) Do not keep rice warm more than 12 hours. May result in odor and discoloration.
- 3) Do not leave a rice scoop or other utensils in the inner pan. The rice may be contaminated with unwanted bacteria and may result in odor.
- 4) Do not add cold rice to the warm rice in the inner pan. May result in odor.
- 5) The color of the cooked rice around the edge of the inner pan and the bottom of the steam vent may be partially whitened.
- 6) Place the the locking handle to "LOCK" position during keeping rice warm and reheating rice.
- 7) In case of rice cooked by other appliance, put the rice into the unit and press "Keep Warm/Reheat" key one time. LCD displays "OH".
- 8) Do not warm cold rice. (Rice may be ruined.)

Reheating

Reheat rice while the unit is in the keep warm mode. It starts reheating by pressing "Keep Warm/Reheat" key and rice becomes hotter after 9 minutes.

1. Press "Keep Warm/Reheat" key
LCD displays "Reheating"

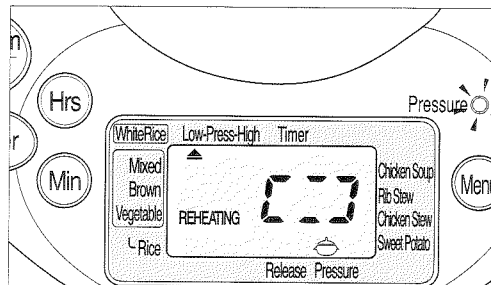

2. Switches to keep warm function automatically after reheating and LCD displays the keep warm time again.

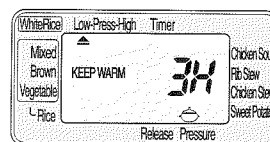

Caution :

May result in discoloration if you use "REHEATING" mode many times (Use one or two Times a day)

NOTE :

LCD displays present time for 2 seconds by pressing "Hrs" key or "Min" Key while keeping warm function

How to adjust the warming temperature

The keep warm temperature may need to be adjusted in the cases mentioned below.

- If the rice still smell even after cleaning the pan often and sterilizing in boiling water.
- The rice is still wet. • The rice has a color change

Adjust it when the keep warm function is not in use.

1. Press the "Cancel" key once before starting the adjustment.

Press the key for five seconds then the indicator changes as shown below with "pip" sound.



(73c shows present warming temperature)

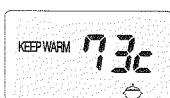

- If the rice smells too bad and is wet.
⇒ Raise the warming temperature about 1~2°C
- If the rice smells too bad, and is dry and has color change.
⇒ Reduce the warming temperature about 1~2°C.

2. Press "Min" key to change the warming temperature.

- When raising the warming temperature.

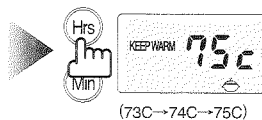

- When reducing the warming temperature.

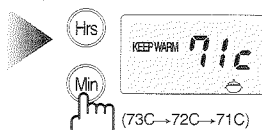

3. The warming temperature is set after about three seconds.

- Also press "Pressure Cook", "Timer" or "Keep Warm/Reheat" key to set it.

Timer Cooking

Confirm that present time is correct

- If time is incorrect, cooking will not be done at the desired time. Adjust present time correctly. Be careful with AM and PM.

1. Turn the Locking handle to "LOCK". (Pressure lamp comes on.)

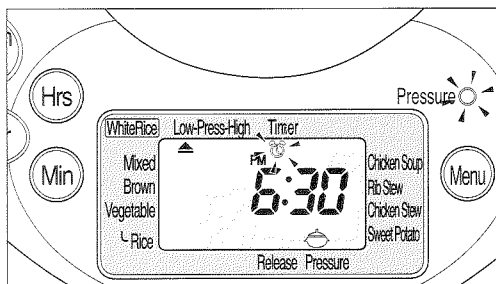

2. Press "Timer" key. LCD displays the time previously set and timer indicator flashes.

3. Set the time to finish cooking by pressing "Hrs" and "Min" keys.

4. Press "Pressure Cook" key.

- Once presetting is completed, the time set appears and timer indicator disappears from the LCD display.

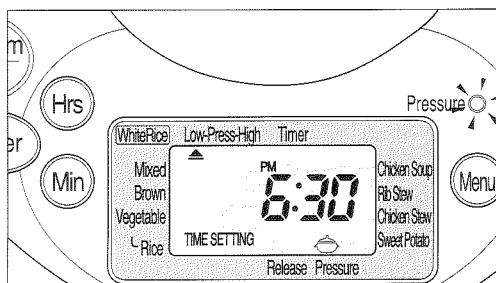

- Adjust the time you want to have by pressing "Pressure Cook" and Leave it for seven seconds without touching it.
- The last preset time is stored in memory even if the unit is unplugged. To use the same completion time simply press the "Timer" key. There is no need to reset it.
- The above picture is for timer cooking to finish at 6:30 PM.

Time Setting Range for Timer Cooking by menu

Menu	Time setting range
White Rice(High Press) Sweet Potato	41 minute to 13 hour
Mixed Rice. Rib Stew Chicken Stew Vegetable Rice. White Rice(Low Press)	51 minute to 13 hour
Brown Rice Chicken Soup	61 minute to 13 hour

Caution for Timer Cooking

- Timer cooking is available within 13 hours from the current time.

If the timer is set for more than 13 hours from the current time on the unit. The LCD displays "13Ho" and the timer will automatically be set to 13 hours.

NOTE :

- Set 12:00 PM for Timer cooking at 12:00 noon.
- Set 12:00 AM for Timer cooking at 12:00 midnight.
- To change the setting, Press "Cancel" key and set again.
- If the timer is set for less than the time setting range, cooking will start immediately. (Refer to the time setting range above)
- The actual cooking time will vary depending on the volume being cooked and the cooking conditions.

What is "power failure Compensation function?"

- If the electricity goes out, the unit remembers previous situation. Therefore, when the electricity comes back on the unit will resume operation at the point when power went out.
- If the electricity fails during cooking, the cooking hours will be delayed for the amount of time the electricity was out.
- Cooking results may differ from normal conditions when there is an electrical outage.

Cleaning and Maintenance

- Unplug the unit and allow it to cool down before cleaning.
- Clean the unit well and frequently. In particular, the lid should be cleaned well. Otherwise, odor may occur during keep warm.
- DO NOT USE: benzine, thinner, scouring powder, abrasive or steel wool.

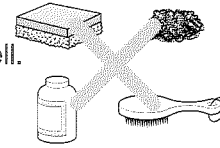

Rubber packing

- Wipe with a damp cloth.
Caution: Do not attempt to remove it from the lid.
- If the packing becomes partially detached, push it into position completely before using the unit.

Inner lid and Metal locking device

- Wipe with a damp cloth.
Caution: Be careful of the metal parts when cleaning.

Inner pan

- Completely wash with mild dishwashing detergent and sponge and dry it.
- Do not use abrasive materials of cleaners.

Body and lid

- Wipe with a damp cloth.
- Clean any food or liquid on the lid or body as soon as possible. If a stain remains, however, it will not be unsanitary.

Upper rim

- Wipe off any accumulated moisture in the area with dish cloth.
- Note: There might be a little stain on the inside of the pan and also the inside surface of the lid but it's safe and sanitary.

Temperature Sensor

- Carefully remove any debris from the heater or temperature sensor.

Steam Vent

- Wipe off any accumulated moisture in the area with dish cloth.

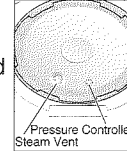

Pressure Controller

- In order to maintain proper operation, periodically clean with the cleaning pin provided to remove any build up.

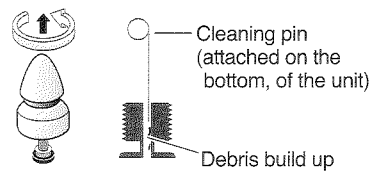

Pressure Controller

- To clean the hole under the pressure controller, lift it up and turn it to the left to remove.
- To attach the controller, put it on the hole and turn it to the right.

Accessories

- Wash with mild dishwashing detergent and sponge and dry it.



Troubleshooting

Check the following items before you contact your sales representative or service center.

Problem	Possible cause	Action
Rice is not cooked.	<ul style="list-style-type: none"> •“Pressure Cook” key was not pressed. 	<ul style="list-style-type: none"> •Press “Pressure Cook” key after selecting Menu and check. “E” on the LCD. •Refer to page 14.
Rice is under cooked or over cooked.	<ul style="list-style-type: none"> •The amount of rice was not measured with the measuring cup provided. •The rice was not rinsed properly. •The rice was soaked in water for a long time. •Too much or too little water was added. 	<ul style="list-style-type: none"> •Refer to page 10–11. •Refer to page 10–11. •Be sure to use the correct water gauge and the appropriate amount of water.
Bean (other grains) is half cooked.	<ul style="list-style-type: none"> •Bean(other grains) was not soaked prior to cooking. 	<ul style="list-style-type: none"> •Soak or steam beans or grains before cooking in the pressure cooker in order to avoid partially cooked beans or grains. Beans should be soaked for - to - minutes or steamed for - to - minutes prior to cooking, depending on your taste.
The rice is soft/hard.	<ul style="list-style-type: none"> •The menu is not selected properly. •The water level was not checked against the gauges on both sides of the inner pot. •The lid was opened before finishing steam process. 	<ul style="list-style-type: none"> •Select menu properly. •Refer to page 10–11. •Open the lid only after the beepsound, after complete steam emission with beep sound.
Overflow while cooking.	<ul style="list-style-type: none"> •The amount of rice was not measured with the measuring cup provided. •The water level was not checked against the gauges on both sides of the pan. •The menu is not selected properly. 	<ul style="list-style-type: none"> •Refer to page 10–11.
Rice smells.	<ul style="list-style-type: none"> •The lid was not closed properly. •Disconnection from an electrical outlet during keep warm. •Keep warm over 12 hours or small amount of rice being kept warm. •Added cold rice or put the scoop or other utensils inside the rice cooker. 	<ul style="list-style-type: none"> •The inner pan is not in proper position—close the lid properly. •Make sure plug is securely inserted into outlet. •Keep warm within 12 hours. •Don't add cold rice or put utensils inside the rice cooker.
“E” mark appears on the LCD.	<ul style="list-style-type: none"> •Temperature sensor problem. 	<ul style="list-style-type: none"> •Consult your nearest service center.

Troubleshooting

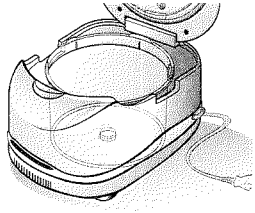
Problem	Possible cause	Action
"E03" mark appears on the LCD and cooking is not finished for a long time.		<ul style="list-style-type: none"> •Product problem. Consult your nearest service center.
Function keys do not work.	<ul style="list-style-type: none"> •The unit is not connected into a 120V electrical outlet. •The inner pan is not in the unit. 	<ul style="list-style-type: none"> •The unit is only for 120V. •Put the inner pan into the unit.
"E01" appears on the LCD. And "Pressure/Cook" and "Timer" key function is disabled.	<ul style="list-style-type: none"> •The locking handle was on "UNLOCK". •Pressure Lamp is out. 	<ul style="list-style-type: none"> •Turn the locking handle to "LOCK".
Rice is scorched.	<ul style="list-style-type: none"> •Debris is outside of the inner pan and on the heating plate. 	<ul style="list-style-type: none"> •Remove debris.
Cooking is not finished at the preset time.	<ul style="list-style-type: none"> •The clock of the rice cooker was not set to the current time correctly. •AM and PM is reversed. •The timer was set for longer than 13 hours from the current time. 	<ul style="list-style-type: none"> •Set current time correctly. •Set AM or PM correctly. •Set the timer cooking within 13 hours.
The rice smells after cooking or during keep warm.	<ul style="list-style-type: none"> •The unit was not cleaned properly after chicken soup, or rib stew, etc. 	<ul style="list-style-type: none"> •Clean the rubber packing and other parts. Refer to page 15.

Troubleshooting

Check the following items before you contact your sales representative or service center.

Problem	Possible cause	Action
When "E04" is blinking or on.	<ul style="list-style-type: none"> • "Cancel" key was pressed during cooking. 	<ul style="list-style-type: none"> • If the "Cancel" key is pressed during cooking and the temperature sensor is under a certain degree, cooking process is canceled and return to reset mode. • If the "Cancel" key is pressed for 2 seconds during cooking and the temperature sensor is over a certain degree, cooking process is canceled and a blinking "E04" will be displayed with a beeper sound of 5 times. After 30 minutes, "E04" stops blinking and lit on with beeper sound of 5 times and the internal steam will be released. Then press "Cancel" key to reset the mode.
When "E05" is blinking or on.	<ul style="list-style-type: none"> • The wrong menu key was chosen or inappropriate ingredients were used for the menu select. 	<ul style="list-style-type: none"> • When water is boiled for a long hours, "E05" appears with 5 times of beeper sounds and the unit will be inoperable. After 30 minutes, "E04" stops blinking and lit on with 5 times of beeper sound and the internal steam will be released. Then press "Cancel" key to reset the mode. • When the menu selected is not complied with it's ingredients, if the sensor temperature is over a certain degree, "E05" blinking and 5 times of beeper sound 3 minutes before the steaming process is complete. • After 30 minutes, "E04" stops blinking and lit on with 5 times of beeper sound and the internal steam will be released. Then press "Cancel" key to reset the mode.

Error Code

Possible Cause

13Ho

- When setting timer cooking longer than 13 hours Set timer cooking within 13 hours.

E..

- Temperature sensor problem.
Consult your nearest service center.

E01

- When pressing the “Pressure Cook” or “Timer” keys while the locking handle is on “UNLOCK”.
Turn the locking handle to “LOCK”.

LJ

- When the inner pan is not placed into the unit.

E03

- Consult your nearest service center.

E04

- It is shown if you press the “Cancel” key while cooking.

E05

- It is shown when cooking course is not properly set.
- It is shown when some substances is stuck on the pan sensor, heating plate or bottom of the pan.
- It is shown when too much water is put in the pan.

Specifications

Power supply		120V AC
Power consumption (Approx.) W	Cooking	1100
	Keeping Warm	135
Cooking Capacity L (Cups)	White rice (High pressure)	0.36 ~ 1.8 (2 ~10)
	White rice (Low pressure)	0.54 ~ 1.44 (3 ~ 8)
	Mixed	0.36 ~ 1.44 (2 ~ 8)
	Brown rice	0.36 ~ 1.44 (2 ~ 8)
Power cord length m(ft)		0.95
Pressure kPa (lb/in ²)		68.6 (0.95)
Weight (Approx.) Kg		6.8 (15)
Dimension cm (inch)	Width	29.8 (11.7")
	Depth	39.4 (15.5")
	Height	31.1 (12.2")

Panasonic Company West
Division of Panasonic Consumer Electronics Company
Specialty Product Section
6550 Katella Ave.
Cypress, California 90630.

Printed in Korea

Part No. 383-474A
SK0103-0