

This Owner's Manual is provided and hosted by [Appliance Factory Parts](http://www.appliancefactoryparts.com).



PANASONIC SR-LE18 Owner's Manual

[Shop genuine replacement parts for PANASONIC
SR-LE18](#)



[Find Your PANASONIC Small Appliance Parts - Select From 148 Models](#)

----- Manual continues below -----

Operating Instructions Manuel d'utilisation 취급설명서 使用說明書

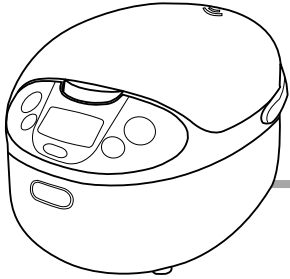

SR-LE10 (1.0L)
 SR-LE18 (1.8L)

● Thank you very much for purchasing **Panasonic** Electronic Rice Cooker/Warmer.
 Read all instructions before use. Save these instructions for future reference.

● Nous vous remercions d'avoir arrêté votre choix sur ce cuiseur de riz / réchaud électronique **Panasonic**.
 Il est recommandé de lire attentivement ce manuel avant d'utiliser l'appareil.

● 이번에 **Panasonic** 전자 밥솥을 구매하여 주셔서 대단히 감사하 는 바입니다.
 이 설명서를 잘 읽으시고 정확하게 사용하십시오. 그 후 소중하게 보관하시어 필요할 때에 읽어주시기를 바랍니다.

● 非常感謝您購買我們的電子鍋。
 請仔細閱讀本說明書，並妥善保存，以備必要時查詢。

Contents

Safety 1
 Precautions

Important 2
 Safeguards

Precautions 3

Parts Description 11

Preparation for 15
 Cooking Rice

Cooking Rice 19

Keeping Rice 21
 Warm

Reheating 23

Stewing 25

Steaming 27

Timer Cooking 29

Cleaning and 31
 Maintenance

If rice is not 33
 cooked well

Troubleshooting 41

Specifications 45

Recipes 47
 (Steaming Vegetables)

Table des matières

Consignes de 1
 sécurité

Précautions à 5
 prendre

Nomenclature 12

Préparation pour 16
 la cuisson du riz

Cuisson du riz 19

Maintien du riz à la 21
 température de service

Réchauffage 23

Cuisson en ragoût 25

Cuisson à l'étuvée 27

Cuisson par 29
 minuterie

Nettoyage et 31
 entretien

Problèmes de 35
 cuisson

Guide de 42
 dépannage

Spécifications 45

차 례

안전 주의사항 1

안전상의 주의 7

각부의 설명 13

취사 준비 17

밥짓기 20

보온 22

재가열 24

푹 끓이는 조리방법 26

찌는 조리방법 28

예약취사 30

손질의 방법 32

밥이 잘 지어지지 37
 않은 경우

고장인가!? 43

사양 46

目錄

安全注意事項 1

注意事項 9

各部位說明 14

準備炊飯 18

炊飯 20

保溫 22

再加熱 24

燉煮的方法 26

蒸的方法 28

預約定時 30

保養 32

如果飯炊煮 39
 不理想時

是否出了故障? 44

規格 46

Safety Precautions

always follow these precautions

Consignes de sécurité

Toujours respecter ces instructions

안전 주의사항

반드시 이 주의사항을 따르십시오.

安全注意事項



請務必遵守！

In order to prevent the risk of danger to the operator of this product or those nearby, and damaging property, be sure to follow the safety precautions outlined below.



Afin d'éviter à l'utilisateur de ce produit et à son entourage tout risque de danger et afin d'éviter tout dommage sur le produit, suivre attentivement les consignes de sécurité indiquées ci-dessous.

이 제품의 조작자 또는 주변 사람에게 가할 수 있는 위험 및 재산상의 손실을 방지하려면 아래의 안전 주의사항을 따르십시오. 為了防止對使用者或他人造成危害，或損壞財產，請務必遵守下面說明的事項。

- The following terms are used for precautions. They are separated depending on the degree of the danger or damage that may occur if their contents are ignored while using this product.
- Les indications suivantes sont utilisées à titre de précaution. Elles sont classées en fonction du degré de danger ou de l'importance des dégâts susceptibles de se produire si elles sont ignorées lors de l'utilisation de ce produit.
- 다음은 주의사항에 대한 용어입니다. 본 제품을 사용하는 동안 본 사용 설명서의 내용을 무시하여 발생할 수 있는 위험 또는 손상 정도에 따라 구분되어 있습니다.
- 由于無視顯示的內容的錯誤使用方法而引起的危害和損害的程度，按照下列區分、說明。

 Warning Mise en garde 경고 警告	This symbol indicates information that, if not heeded, could possibly result in loss of life or serious injury. Ce symbole identifie des mesures dont le non respect peut entraîner des blessures graves, voire mortelles. 이 표시의 난은 사망 또는 중상 등을 입을 가능성이 상정된다. 의 내용입니다. 該記號表示的是“可能引起死亡或重傷”的內容。
 Caution Attention 주의 注意	This symbol indicates information that, if not heeded, could result in injury or property damage. Ce symbole identifie des mesures dont le non respect peut entraîner des blessures graves et des dommages matériels importants. 이 표시의 난은 상해를 입을 가능성 또는 물적 손해만이 발생하는 가능성이 상정된다. 의 내용입니다. 該記號表示的是“可能傷人或損害物品”的內容。

- The following signs are used to explain operations that you are requested to follow. They are separated as shown below. (Below are examples of the signs used in this manual.)
- Les pictogrammes suivants sont utilisés pour expliquer les opérations que vous devez suivre. Ils sont classés comme indiqué ci-dessous (Voir ci-dessous des exemples de pictogrammes utilisés dans ce manuel).
- 다음 기호는 사용자가 준수해야 할 조작을 설명하는 데 사용됩니다. 아래와 같이 구분되어 있습니다. (아래에 본 사용 설명서에서 사용되는 기호에 대한 예가 있습니다.)
- 遵守的內容種類以下列圖形區分表示、說明。(下列的圖形為一例。)

	This sign designates actions that you must never do (prohibited actions). Ce pictogramme désigne ce que vous ne devez faire en aucun cas (actions interdites). 이 기호는 사용자가 절대 해서는 안 되는 행동을 나타냅니다(금지된 행동). 本圖形表示不得操作的“禁止”事項。
	This sign designates actions that you must do (required actions). Ce pictogramme désigne ce que vous devez toujours faire (actions obligatoires). 이 기호는 사용자가 반드시 해야 하는 행동을 나타냅니다(필요한 행동). 本圖形表示必須執行的“強制”的事項。

Warning Mise en garde 경고 警告



May result in fire or explosion.
Risque d'incendie ou d'explosion.
화재가 발생하거나 폭발할 수 있습니다.
發生爆炸或火災的原因。

- Never use this vacuum cleaner near or to clean up flammable or burning items or materials (i.e., gasoline, kerosene, thinner, or burning cigarettes).
- Ne jamais utiliser cet aspirateur à proximité d'éléments ou de matériaux inflammables ou incandescents (essence, kérosène, diluant ou cigarettes allumées).
- 이 진공 청소기를 가연성 또는 불이 붙어 있는 물건 또는 물질을 청소하는 데 절대 사용하지 마십시오(예: 가솔린, 등유, 희석제 또는 불이 붙어있는 담배).
- 請勿在周圍使用、抽吸帶煙火或易燃的物品(煤油、汽油、稀釋劑、未熄滅的香煙等)。

IMPORTANT SAFEGUARDS

When using electrical appliances, basic safety precautions should always be followed, including the following:

1. Read all instructions.
2. Do not touch hot surfaces. Use handles or knobs.
3. To protect against electrical hazards do not immerse cord, plugs, and Rice Cooker, except pan, in water or other liquid.
4. Close supervision is necessary when any appliance is used by or near children.
5. Unplug from outlet when not in use and before cleaning. Allow cooling before putting on or taking off parts.
6. Do not operate any appliance with a damaged cord or plug or after the appliance malfunctions, or has been damaged in any manner. Return appliance to the nearest authorized service facility for examination, repair or adjustment.
7. The use of accessory attachments not recommended by the appliance manufacturer may be hazardous.
8. Do not use outdoors.
9. Do not let cord hang over edge of table or counter, or touch hot surfaces.
10. Do not place on or near a hot gas or electric burner, or in a heated oven.
11. Extreme caution must be used when moving an appliance containing hot oil or other hot liquids.
12. Always attach plug to appliance first, then plug cord into the wall outlet. To disconnect, turn any control to "off", then remove plug from wall outlet.
13. Do not use appliance for other than intended use.

14. SAVE THESE INSTRUCTIONS

15. This product is intended for household use.

NOTE

- A. A short power supply cord (or cord set) is to be provided to reduce the hazards resulting from becoming entangled in or tripping over a longer cord.
- B. Longer cord set or extension cords are available and may be used if care is exercised in their use.
- C. If a long cord set or extension cord is used,
 - (1) the marked electrical rating of the cord set or extension cord should be at least as great as the electrical rating of the appliance.
 - (2) if the appliance is of the grounded type, the extension cord should be a grounding-type three-wire cord, and
 - (3) the longer cord should be arranged so that it will not drape over the countertop or tabletop where it can be pulled on by children or tripped over accidentally.

This appliance has a polarized plug; (one blade is wider than the other). As a safety feature, this plug will fit into a polarized outlet only one way. If the plug does not fit fully into the outlet, reverse the plug. If it still does not fit, contact a qualified electrician. Do not attempt to defeat this safety feature.

Warning

■ Do not place your hand or face over or near the steam vent.

May result in burns.

- Keep children away.



■ Do not plug or unplug the rice cooker with wet hands.

May result in electrical shock.



■ Do not let children or those who are unfamiliar with the operations operate the rice cooker. Keep the rice cooker out of the reach of children.

Children may receive burns or be injured.

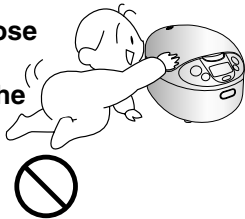

■ Do not immerse the unit in water or expose it to water.

May result in shorting or electrical shock.

- If water enters the main unit, consult your nearest retailer or service center.

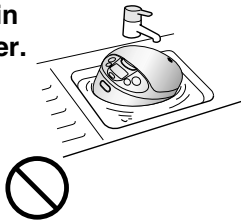

■ Do not damage the power cord or the power plug.

(Avoid damage to the power cord. Do not attempt to modify the power cord. Keep the power cord away from high temperatures. Avoid unnecessary bending, twisting, pulling of the power cord. Do not attempt to tie the power cord in a bundle.)

Using a damaged power cord may result in electrical shock, shorting, or fire.

- If the power cord or the power plug is damaged, consult your nearest retailer or service center for repair.

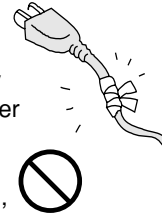

■ Do not attempt to modify, disassemble, or repair the unit.

May result in fire, electrical shock, or injury.

- Consult your nearest retailer or service center for repair.



■ Be sure to insert the power plug firmly into an electrical outlet.

Improper insertion may result in electrical shock or fire due to overheating

- Do not use a damaged plug or a warped outlet.

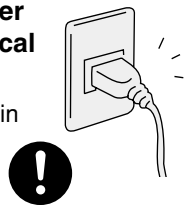

■ Remove dust from the power plug periodically.

Excessive dust on the power plug may reduce insulation due to humidity, etc., resulting in fire.

- Unplug and wipe dust off the power plug with a dry cloth.

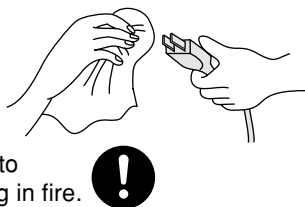

■ Do not use the unit at a voltage other than 120 V AC or the rated voltage of an electrical outlet or a wiring accessory.

When connecting a number of cords to a single electrical outlet, pay attention to the total wattage. If the total wattage exceeds the rated wattage of an electrical outlet or an extension cord, fire may be caused due to overheating.

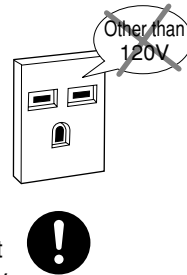

⚠ Caution

- **Do not use the rice cooker on an unstable surface or a mat easily affected by heat.**

Possible toppling of the unit may cause injury or fire.



- **Do not touch the metal part on the inside of the lid during or just after use.**

May receive burns.

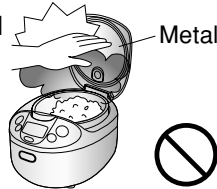

- **Do not place things near the steam vent.**

The part exposed to steam may be deformed.

- When using the rice cooker in a cabinet, etc., leave enough clearance to permit steam to escape.



- **Do not use the unit in wet locations or high temperatures.**

May cause electrical shock, electrical leaks or fire.

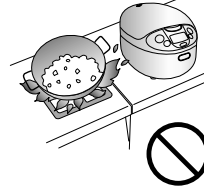

- **Use only the specified pan.**

Burns or injury may be received due to overheating or abnormal operations.



- **Do not touch the hook button while carrying the rice cooker.**

Cover will open and may cause injury or burns.



- **Be sure to grasp the power plug when unplugging.**

Pulling the cord may cause electrical shock, shorting or fire.



- **Unplug the rice cooker from the electrical outlet when not in use.**

May cause electrical shock, electrical leaks or fire due to insulation deterioration.



- **Be sure to hold onto the power plug when rewinding it to keep from being hit by the plug.**

May receive injury.



- **Please use with dry hands.**

Touching high temperature parts may cause burns.



To avoid damage to the non-stick coating on the cooking pan.

- **Avoid tapping or scratching the pan**



- **Do not put spoons or other utensils in the pan**



- **Do not attempt to clean the pan with scouring powder, steel wool or a nylon scouring pad.**

Clean the pan with a sponge



- **Do not use vinegar.**

- **Wash the pan immediately after cooking with any seasoning.**

- **Do not attempt to wash rice with a whisk.**

- **When using a metal tablespoon, be careful not to damage the coating.**

Very Important

- **Keep the outside of the pan and the pan sensor clean and dry.**

Bottom and side



Pan sensor

Heating plate

Any foreign substance may cause the rice cooker to malfunction.

- **To pull the power plug, pull it horizontally as shown.**

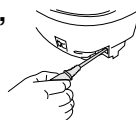

- **Close the lid when in use.**

- **Do not use the rice cooker in direct sunlight.**

The rice cooker may malfunction.

- **Do not cover the lid with a cloth.**

The lid may become deformed, cracked or discolored.

- **Unplug the rice cooker from the electrical outlet when the pan is removed.**

Parts Description

Figures show SR-LE10 (1.0L type)

Part Identification

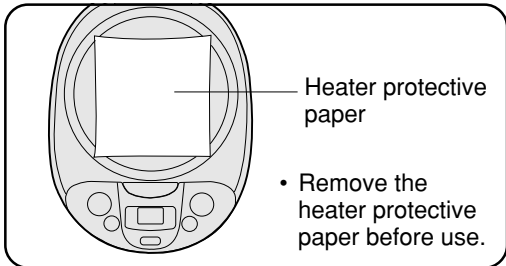
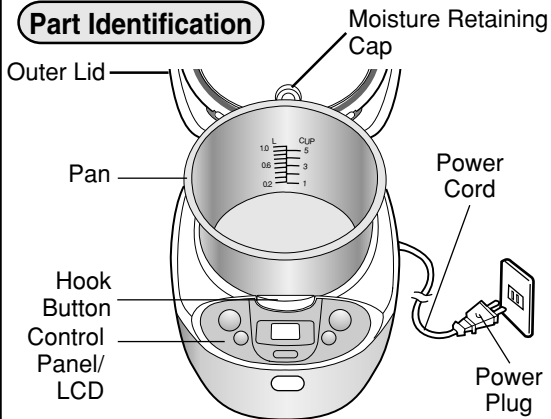

Accessories

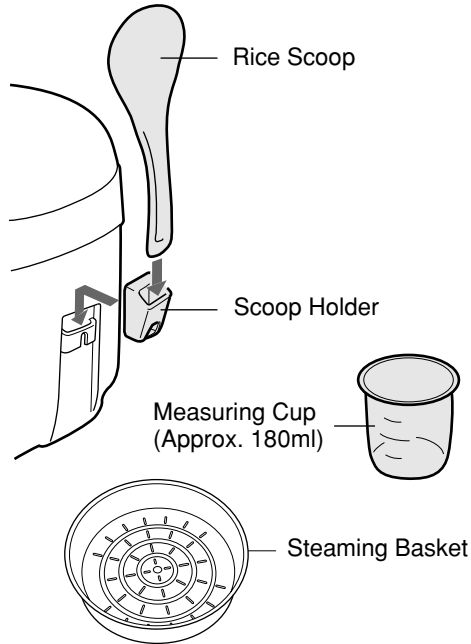

Control Panel

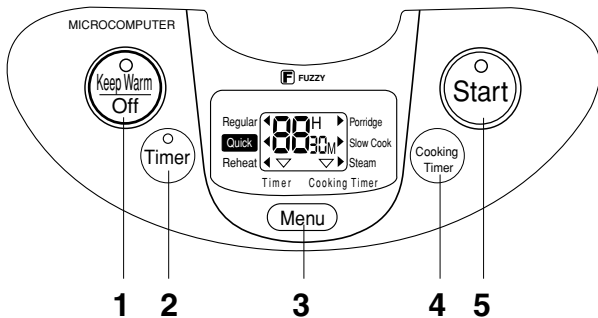

1	Keep Warm/Off	Turns on/off the keep warm function. Turns off the timer function. Cancels preset operations.
2	Timer	Sets the timer.
3	Menu	Selects a cooking menu.
4	Cooking Timer	Sets the cooking time for the "Porridge", "Slow Cook" or the "Steam" menu.
5	Start	Starts cooking or timer cooking.

LCD / Menu

LCD

Displays selected cooking menu, the cooking time and other information.

Menu

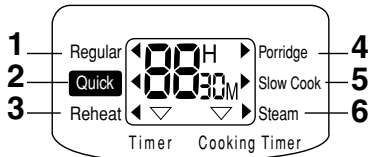

1	Regular	Cooks white rice into regular hardness.
2	Quick	Cooks white rice faster than the "Regular" menu by 10 to 20 minutes.
3	Reheat	Use for reheating cold rice.
4	Porridge	Cooks white rice into porridge. You can select the "thick" type or the "thin" type by adjusting the water level.
5	Slow cook	Stews meat or vegetables. (You can select the cooking time in 30-minute increments from 1 to 4 hours.)
6	Steam	Stews vegetables or other foods. (You can select the cooking time in 1-minute increments from 1 to 60 minutes.)

Preparation for Cooking Rice

The minimum and maximum amount of rice that can be cooked will vary depending on the menu chosen.

Menu	Cooking Capacity (Measuring cup)	
	SR-LE10 (1.0L)	SR-LE18 (1.8L)
White Rice	1 cup to 5.5 cups	3 cup to 10 cups
Thick Porridge	0.5 cup to 1.5 cups	1 cup to 3 cups
Thin Porridge	0.5 cup to 1 cup	0.5 cup to 2 cups
Slow Cook	1.8qts (1.7 L)	3.2qts (3.1 L)

1 Measure rice. (Use the measuring cup [approx. 180 ml] provided with the rice cooker.)

Measure in level cups.



2 Rinse rice. (Rinse rice in a container other than the rice cooker pan)

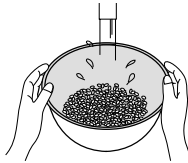

(1) Rinse rice quickly in a lot of water, then quickly drain.



(2) Rinse rice evenly and quickly so that rice grains rub each other.

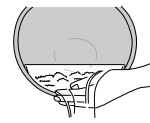

(3) Rinse rice with a lot of water, then drain.

(4) Repeat steps (2) and (3) until water runs clear.

Note: Rinse rice thoroughly. Otherwise, rice may scorch or smell like bran.

3 Add water.

Put the rinsed rice into the pan and add water to the appropriate water level depending on the amount of rice and the menu chosen. (The figure shows the water level for cooking three cups of white rice.) To measure the water level correctly, place the pan on a flat surface and check the water level against the gauges at both sides of the pan.

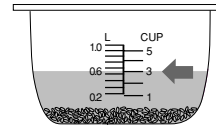

Volume of rice (cup)	Volume of water (measuring cup)			
	Thick Porridge		Thin Porridge	
	SR-LE10	SR-LE18	SR-LE10	SR-LE18
1/2	2 1/2	—	3 1/2	3 1/4
1	5	5	6 1/2	6 1/2
1 1/2	7 1/4	7	—	9 3/4
2	—	9	—	12 3/4
2 1/2	—	11	—	—
3	—	13	—	—

4 Set the pan in the rice cooker and close the outer lid.

Be sure to fit the moisture retaining cap into the outer lid.



5 Plug the rice cooker into an electrical outlet.

☛ Refer to page 18 for cooking.

☛ Refer to page 28 for timer cooking.

1

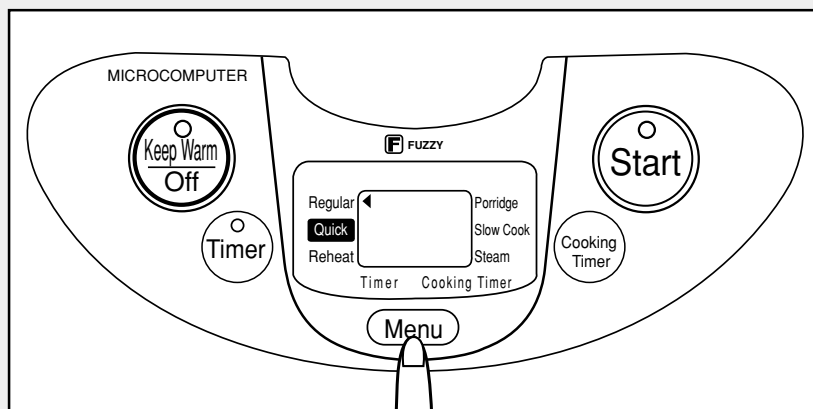

Cooking Rice

1 Select a menu. Each pressing of the [Menu] key moves ◀ (or ▶) from one menu to another as follows.

“Regular” → “Quick” → “Reheat” → “Porridge” → “Slow Cook” → “Steam” → “Regular” →...

(The figure shows the indication on the LCD when the “Regular” menu is selected.)

2 Press the [Start] key.

The [Start] lamp lights up when cooking starts. The remaining time counter will appear on the LCD display when the remaining time reaches the time shown on the chart below.

Quick	Regular or Porridge
9 minutes	13 minutes

When cooking is finished, the rice cooker beeps and automatically switches to the keep warm mode.

3 Fluff (mix) rice completely within 30 minutes after cooking is finished.

Rice is ready to be served.

Standard cooking time (Approx. in minutes)		
Regular	Quick	Porridge
50	29 to 39	62 to 78

Note Do not use the keep warm function for porridge or mixed rice to prevent rice from producing odor, becoming discolored or sticky. Press the [Keep Warm/Off] key to turn off the keep warm function.

Cuisson du riz

1 Sélectionner un menu. Chaque pression de la touche [Menu] appelle l’affichage d’un menu différent dans l’ordre suivant.

“Regular” → “Quick” → “Reheat” → “Porridge” → “Slow Cook” → “Steam” → “Regular” →...

(L’illustration à la page précédente montre l’affichage lorsque le menu “Regular” a été sélectionné.)

2 Appuyer sur [Start].

Le voyant [Start] s’allume lorsque la cuisson s’amorce.

Le compte à rebours de la durée restante apparaît sur l’afficheur à cristaux liquides lorsque la durée atteint le temps indiqué au tableau ci-dessous.

Quick	Regular ou Porridge
9 minutes	13 minutes

La cuisson terminée, le cuiseur émet une tonalité d’avertissement et passe automatiquement dans le mode maintien de température de service.

3 Moins de 30 minutes après la fin de la cuisson, aérer (mélanger) le riz.

Le riz est alors prêt à servir.

Temps de cuisson (en minutes)		
Regular	Quick	Porridge
50	29 à 39	62 à 78

Remarque Ne pas utiliser la fonction maintien au chaud pour le porridge ou le riz mélangé car il pourrait dégager des odeurs ou devenir décoloré ou collant. Appuyer sur [Keep Warm/Off] pour désactiver cette fonction.

1

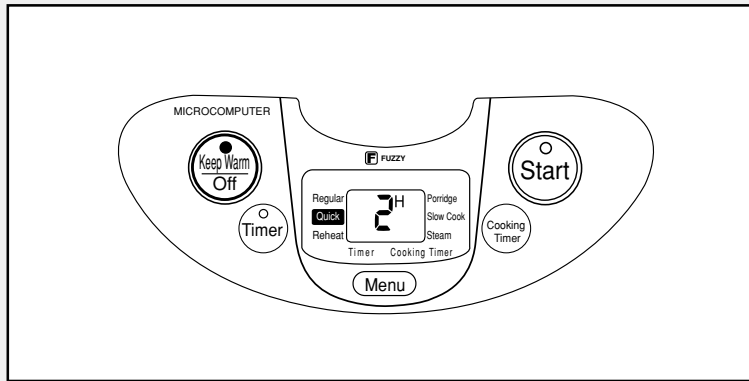

Keeping Rice Warm

When cooking is finished, the rice cooker automatically switches to the keep warm mode.

Note

- 1) Do not use the keep warm function for mixed rice, or porridge to prevent mixed rice from releasing odors or discoloration, and porridge from becoming gluey.
- 2) Do not keep rice warm more than 12 hours. May result in odor and discoloration.
- 3) Do not leave rice scoop or other utensils in the pan. The rice may be contaminated with unwanted bacteria and may cause odors.
- 4) Do not add cold rice to the warm rice in the pan. May result in odor.

Depending on the elapsed warming time, the unit operates as follows:

	Elapsed time in the keep warm mode	Display	Operation
1	Less than 24 hours	Elapsed time in the keep warm mode (hours)	Operating in the keep warm mode (The [Keep Warm/Off] lamp is lit.)
2	24 to 96 hours	No display	Operating in the keep warm mode (The [Keep Warm/Off] lamp is lit.)
3	After 96 hours	Standby condition	The keep warm function will be automatically turned off.

Maintien du riz à la température de service

La cuisson terminée, le cuiseur passe automatiquement dans le mode maintien de température de service.

Remarque

- 1) Ne pas utiliser la fonction maintien au chaud pour le riz mélangé ou le porridge il pourrait dégager des odeurs ou devenir décoloré ou gluant.
- 2) Ne pas maintenir le riz au chaud plus de 12 heures. Cela pourrait dégager une mauvaise odeur et décolorer le riz.
- 3) Ne pas laisser la louche ou tout autre ustensile dans la casserole. Cela pourrait contaminer le riz et lui donner une mauvaise odeur.
- 4) Ne pas ajouter de riz froid au riz chaud dans la casserole. Cela pourrait provoquer le dégagement d'une mauvaise odeur.

Selon le temps de maintien au chaud écoulé, le cuiseur fonctionne comme suit:

	Temps écoulé dans le mode température de service	Affichage	Mode d'opération
1	Moins de 24 heures	Temps écoulé dans le mode température de service (heures)	Mode température de service (Le voyant [Keep Warm/Off] est allumé.)
2	24 à 96 heures	Aucun affichage	Mode température de service (Le voyant [Keep Warm/Off] est allumé.)
3	Après 96 heures	État d'attente	La fonction maintien au chaud est automatiquement désactivée.

1

2

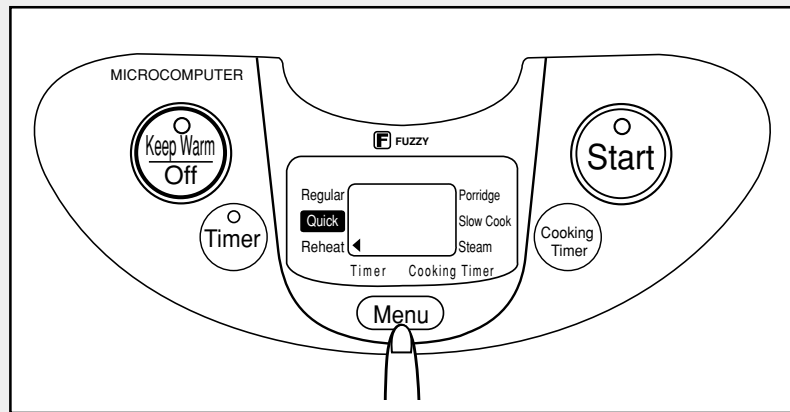
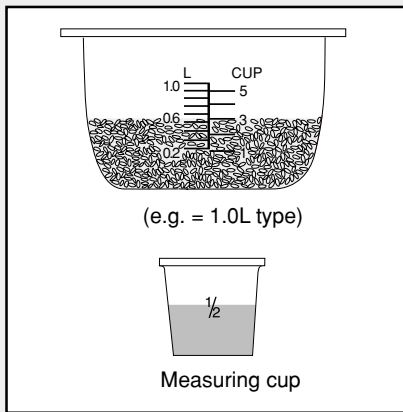

Reheating

1 Fluff the cold rice in the pan.

Before reheating cold rice, add water as shown in the table below with the measuring cup provided.

Volume of cold rice (refer to water level scale on the pan)	Volume of water (cup)	
	1.0 L	1.8 L
1	1/4	–
2	1/2	–
3	1/2	1/2
4	–	1/2
5	–	1
Cold rice reheating maximum capacity (level)	3	5

e.g.: Figure 1 shows the volume of cold rice at level 3 and amount of water have to add in is 1/2 cup.

2 Press [Menu] key to select “Reheat” function.

3 Press [Start] key.

The [Start] lamp lights to indicate that reheating process has started. The LCD will display ‘20’, regardless of how much rice is being reheated, indicating that it will take 20 minutes for reheating process to finish. The displayed time will be reduced one minute at a time. The rice cooker beeps when the reheating process is complete and automatically switches to keep warm. The [Keep Warm/Off] light goes on. Fluff (mix) the rice as soon as the reheating process is complete in order to ensure good tasting rice.

Note

- 1) Do not add cold rice exceeding the maximum capacity.
- 2) Reheat cold rice only once to avoid deterioration of flavor.
- 3) Use the reheat function for white rice only.

Réchauffage

1 Aérer le riz dans la casserole.

Avant de réchauffer le riz froid, ajouter de l'eau avec la tasse graduée incluse selon la quantité indiquée au tableau.

Volume de riz froid (voir l'échelle de niveau d'eau sur la casserole)	Volume d'eau (tasse)	
	1,0 L	1,8 L
1	1/4	–
2	1/2	–
3	1/2	1/2
4	–	1/2
5	–	1
Capacité maximale de réchauffage de riz froid (niveau)	3	5

Ex. : La figure 1 montre le volume de riz froid au niveau 3 et la quantité d'eau nécessaire, soit 1/2 tasse.

2 Appuyer sur la touche [Menu] pour sélectionner la fonction “ Reheat ” (Réchauffage).

3 Appuyer sur la touche [Start].

Le voyant [Start] s'allume pour indiquer que le réchauffage a débuté. L'afficheur indique “20”, quelle que soit la quantité de riz à réchauffer, confirmant qu'il faut 20 minutes avant la fin du réchauffage. La durée affichée diminue d'une minute à la fois. Le cuiseur de riz émet un signal sonore lorsque le réchauffage est terminé et se commute automatiquement en mode maintien au chaud. Le voyant [Keep Warm/Off] s'allume. Aérer (mélanger) le riz le plus tôt possible après la fin du réchauffage pour obtenir un riz de bon goût.

Remarque

- 1) Ne pas dépasser la capacité maximale de riz froid.
- 2) Réchauffer une seule fois le riz froid pour éviter la perte de saveur.
- 3) Utiliser la fonction de réchauffage avec du riz blanc seulement.

1

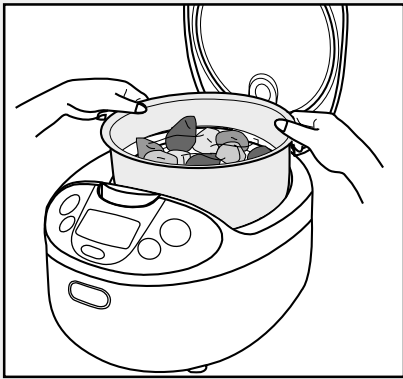

2

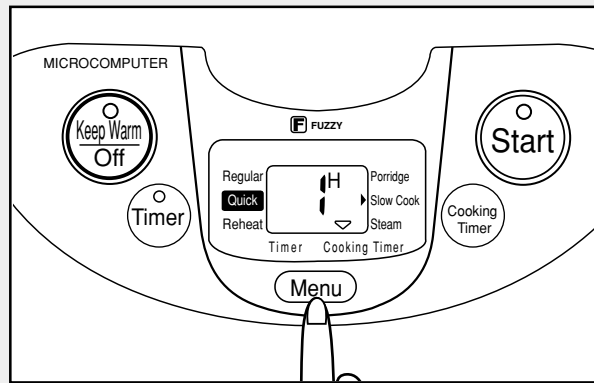

Stewing

Use the “Slow Cook” menu for stewing. You can set the cooking time in 30-minute increments from 1 to 4 hours.

- 1** Put ingredients and seasonings into the pan and set the pan into the rice cooker. Close the outer lid and plug the rice cooker into an electrical outlet.
- 2** Press the [Menu] key to select the “Slow Cook” menu.
“1H” (1 hour 0 minutes) is displayed on the LCD as the default cooking time for the “Slow Cook” menu.
- 3** Press the [Cooking Timer] key to set the cooking time.
Each pressing of the [Cooking Timer] key changes the time as follows:
“1H” → “1H30M” → “2H” → ... → “3H30M” → “4H” → “1H”
- 4** Press the [Start] key when the desired cooking time is displayed.
The [Start] lamp lights up when stewing starts. The LCD will change every thirty minutes to show the remaining cooking time. The display will count down by one-minute increments when the remaining time reaches one hour. The unit will automatically switch to the Keep Warm mode when the desired cooking time is complete.

For example: If the desired cooking time is two hours, the remaining cooking time is displayed on the LCD as follows:

“2H” → “1H30M” → “1H” → “59M” → “58M” → ... “1M”

Cuisson en ragoût

Utiliser le menu “Slow Cook” pour la cuisson en ragoût. Le temps de cuisson se règle par période de 30 minutes, entre 1 à 4 heures.

- 1** Mettre les ingrédients et les assaisonnements dans la casserole puis placer celle-ci dans le cuiseur. Fermer le couvercle extérieur, puis brancher le cuiseur.
- 2** Appuyer sur [Menu] pour sélectionner le menu “Slow Cook”.
L’indication “1H” (1 heure 0 minute) s’affiche (temps de cuisson par défaut dans le mode “Slow Cook”).
- 3** Appuyer sur la touche [Cooking Timer] pour régler la durée de cuisson.
Chaque pression sur la touche [Cooking Timer] change la durée comme suit:
“1H” → “1H30M” → “2H” → ... → “3H30M” → “4H” → “1H”
- 4** Lorsque le temps de cuisson désiré s’affiche, appuyer sur [Start].
Le voyant [Start] s’allume pour indiquer que la cuisson en ragoût s’amorce. L’indication sur l’afficheur change à chaque trente minutes pour indiquer la durée restante de cuisson. Lorsque la durée restante passe sous une heure, l’afficheur fait le décompte une minute à la fois. L’appareil se commut automatiquement en mode maintien au chaud lorsque la durée de cuisson choisie est écoulée.

Par exemple: Si la durée de cuisson est de deux heures, la durée restante est indiquée sur l’afficheur comme suit:

“2H” → “1H30M” → “1H” → “59M” → “58M” → ... “1M”

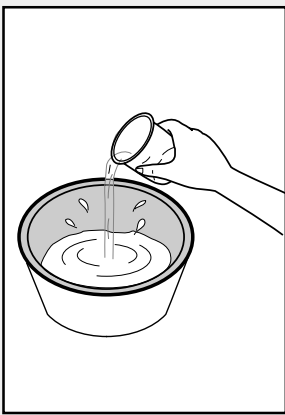
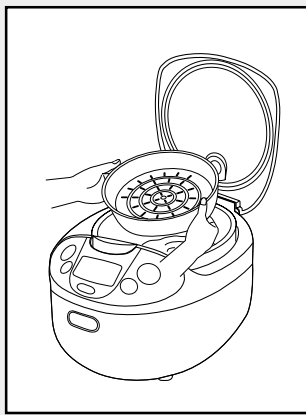
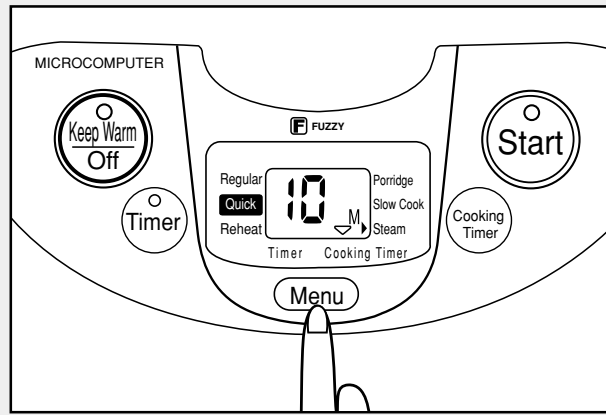
1**2****3**

Steaming

- 1** Using the measuring cup provided, place the amount of water shown below into the pan, and place the pan in the rice cooker.

1.0L type → 450ml (2.5 cups)

1.8L type → 630ml (3.5 cups)

- 2** Set the steaming basket in the pan and place ingredients on the plate. Close the outer lid.
- 3** Press the [Menu] key to select the “Steam” menu.
“10M” (10 minutes) is displayed on the LCD as the default cooking time for the “Steam” menu.
- 4** Press the [Cooking Timer] key to set the cooking time. You can select the cooking time from 1 to 60 minutes.
Each pressing of the [Cooking Timer] key changes the time as follows:
“10M” → “11M” → “12M” → ... “60M” → “1M” → “2M” → ... “10M”
- 5** Press the [Start] key when the desired cooking time is displayed.

The [Start] lamp lights when steaming starts. The remaining cooking time is displayed on LCD and it counts down in one minutes increments.

When the preset cooking time elapses or when water evaporates completely, the rice cooker beeps and automatically switches to the keep warm mode.

Cuisson à l'étuvée

- 1** À l'aide de la tasse graduée fournie, placer la quantité d'eau indiquée ci-dessous dans la casserole et déposer la casserole dans le cuiseur de riz.

Type 1,0 L → 450 ml (2,5 tasses)

Type 1,8 L → 630 ml (3,5 tasses)

- 2** Placer le panier de cuisson à la vapeur dans la casserole et déposer les aliments dans le panier. Refermer le couvercle extérieur.
- 3** Appuyer sur [Menu] pour sélectionner le menu “Steam”.
L'indication “10M” (10 minutes) s'affiche (temps de cuisson par défaut dans le mode de cuisson à l'étuvée).
- 4** Appuyer sur la touche [Cooking Timer] pour régler la durée de cuisson. Il est possible de choisir une durée de cuisson de 1 à 60 minutes.
Chaque pression sur la touche [Cooking Timer] change la durée comme suit:
“10M” → “11M” → “12M” → ... “60M” → “1M” → “2M” → ... “10M”
- 5** Lorsque le temps de cuisson désiré s'affiche, appuyer sur [Start].

Le voyant [Start] s'allume pour indiquer que la cuisson à l'étuvée s'amorce. La durée restante de cuisson est indiquée sur l'afficheur et le décompte s'effectue une minute à la fois.

Une fois le temps de cuisson écoulé ou lorsque l'eau s'est complètement évaporée, l'avertisseur se déclenche et le cuiseur passe automatiquement dans le mode température de service.

1

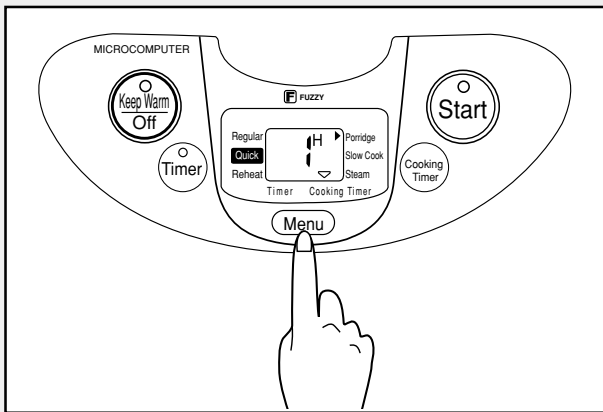

2

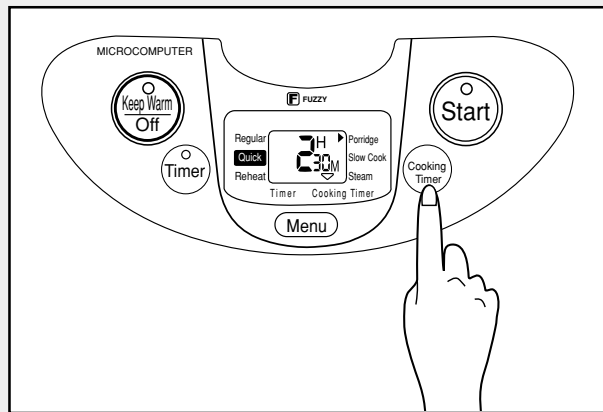

Timer Cooking

This is a count down timer, not a clock timer, so, the rice cooker will complete cooking when the number of hours the Timer was set for elapses. The Timer begins to count down from the time the **[Start]** key is pressed. For example, if the Timer is set for 4H 30M cooking will be completed 4 hours and 30 minutes from the time the **[Start]** key was pressed, not at 4:30a.m. or 4:30p.m.. Timer cooking is not recommended when using seasonings or other ingredients since they settle to the bottom of the pan which may cause abnormal cooking.

Applicable Menus for Timer Cooking and Recommended Time Setting Range.

Menu	Time Setting Range
Regular	1 ~ 13 hours
Porridge	Cooking Time ~ 13 hours

e.g.: To complete 2-hour 30-minute Porridge 6 hours later.

- 1** Select "Porridge" using the **[Menu]** key.
- 2** Set the cooking time (2:30) by pressing **[Cooking Timer]** key before setting the timer.
- 3** Press the **[Timer]** key to select the timer setting. (**[Start]** light flashes)

Press the **[Timer]** key until 6H is displayed. The first time the **[Timer]** key is pressed the previous timer setting will be displayed. The timer will advance 30 minutes each time the **[Timer]** key is pressed. You can keep the key pressed so that the timer changes continuously. Timer for "Porridge" cannot be set for shorter than the cooking time.

- 4** Press the **[Start]** key.

The **[Start]** lamp goes off and the **[Timer]** lamp lights. Timer cooking is set. As soon as cooking starts, the **[Timer]** lamp goes off and the **[Start]** lamp lights. If the selected menu is Regular and the Timer is set for 1 hour, or the selected menu is Porridge and the Timer setting is the same as the cooking timer's, the **[Start]** lamp will light and cooking will begin as soon as the **[Start]** key is pressed.

Note: Timer setting cannot be used for "Quick", "Reheat", "Slow Cook" and "Steam".

Cuisson par minuterie

Comme il s'agit d'une minuterie à rebours et non pas d'une horloge, le cuseur de riz arrête la cuisson lorsque la durée entrée s'est écoulée sur la minuterie. Par exemple, si la minuterie est réglée à 4 h 30 min, la cuisson s'arrête 4 h et 30 min après qu'une pression a été exercée sur la touche **[Start]**, non pas à 4 h 30 ou 16 h 30. La cuisson par minuterie n'est pas recommandée lorsque des assaisonnements ou autres ingrédients sont utilisés car ceux-ci se déposent au fond de la casserole et donnent une cuisson anormale.

Menus applicables à la cuisson par minuterie et durées de cuisson recommandées

Menu	Plage de temps de cuisson
Regular	1 à 13 heures
Porridge	Durée de cuisson ~ 13 heures environ

Ex. : Pour compléter 6 heures plus tard un porridge en 2 h 30 min.

- 1** Sélectionner "Porridge" (Gruau) à l'aide de la touche **[Menu]**.
- 2** Régler la durée de cuisson (2 h 30 min) en appuyant sur la touche **[Cooking Timer]** avant de régler la minuterie.
- 3** Appuyer sur la touche **[Timer]** pour sélectionner le réglage de la minuterie. (Le voyant **[Start]** clignote)

Appuyer sur la touche **[Timer]** jusqu'à ce que l'afficheur indique "6H". Lors de la première pression sur la touche **[Timer]**, l'afficheur indique le réglage précédent de la minuterie. La minuterie avance de 30 minutes à chaque pression sur la touche **[Timer]**. Il est possible de maintenir une pression pour avancer la durée de manière continue. La minuterie pour le "Porridge" (Gruau) ne peut pas être réglée à une valeur inférieure à celle de la durée de cuisson.

- 4** Appuyer sur la touche **[Start]**.

Le voyant **[Start]** s'éteint et le voyant **[Timer]** s'allume. La cuisson par minuterie est alors réglée. Dès que la cuisson débute, le voyant **[Timer]** s'éteint et le voyant **[Start]** s'allume. Si le menu "Regular" (Cuisson normale) est choisi et la minuterie est réglée à 1 heure, ou si le menu "Porridge" (Gruau) est choisi et la minuterie est réglée à la même valeur que celle de la durée de cuisson, le voyant **[Start]** s'allume et la cuisson débute dès qu'une pression est exercée sur la touche **[Start]**.

Nota : Le réglage de la minuterie ne peut pas être utilisé pour les fonctions "Quick" (Rapide), "Reheat" (Réchauffage), "Slow Cook" (Cuisson lente) et "Steam" (Cuisson à la vapeur).

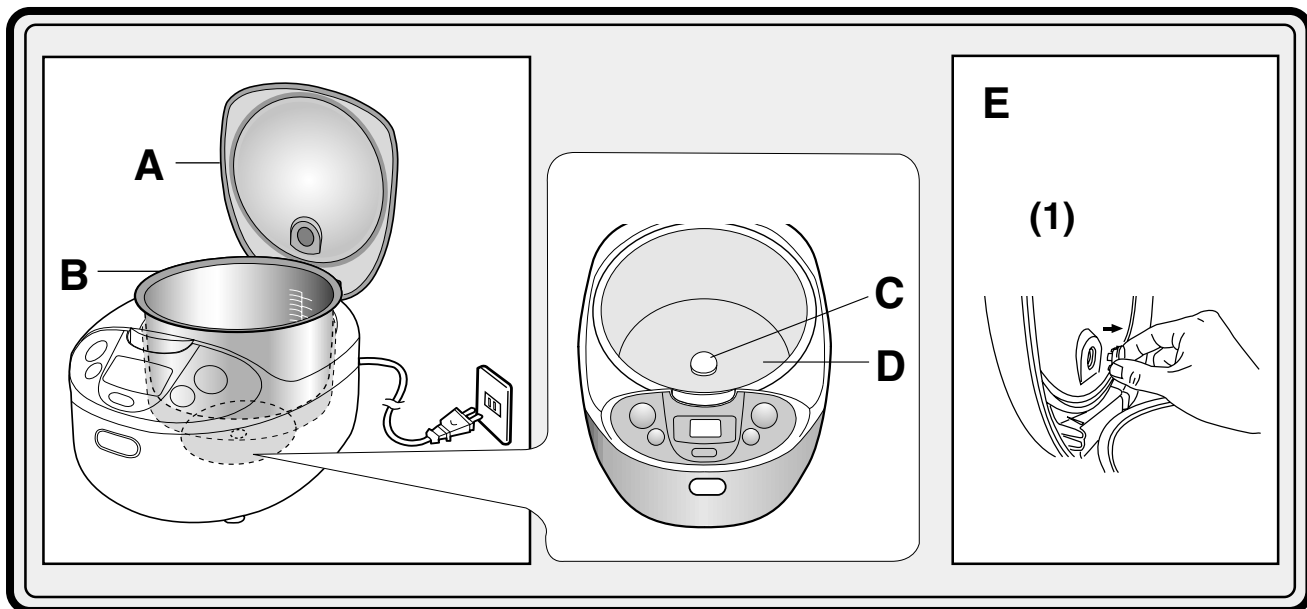

Cleaning and Maintenance

Unplug the rice cooker and allow the unit to cool before cleaning.

Do not use benzine, thinner, scouring powder, or steel wool.

A Main unit and outer lid

Wipe with a damp cloth. If you continue using the rice cooker with a soiled lid, the soil will not come off. The outer lid may be discolored or stained with the soil, but is not unsanitary.

*Do not wash with dishwashing detergent. Do not immerse the main unit in water.

B Pan

Wash with dishwashing detergent and a sponge. Wipe water off the pan.

If the pan is deformed or the non-stick coating is worn away, purchase a new pan at your nearest retailer and replace the old pan with the new one.

C D Pan sensor and heating plate

Wipe with a damp cloth, if caked with foreign substances.

E Moisture retaining cap

Pull outwards to remove the moisture retaining cap (1). Wash it with water and wipe off any moisture (2). Wipe the inside of the hole with damp cloth (3). Securely fit the cap by pushing it (4).

F Accessories

Wash with dishwashing detergent and a sponge. Rinse and wipe water off.

Nettoyage et entretien

Avant de le nettoyer, débrancher le cuiseur et le laisser refroidir.

Ne jamais utiliser de benzène, de solvant ou de détergent abrasif, ni de tampon à récurer.

A Unité principale et couvercle extérieur

Nettoyer avec un chiffon humide. Si le cuiseur est utilisé avec un couvercle sale, la saleté aura tendance à s'incruster. Bien que le couvercle pourrait devenir décoloré ou taché, il ne présente aucun risque de nocivité.

*Ne pas utiliser de savon à vaisselle. Ne pas immerger l'appareil.

B Casserole

Laver la casserole avec du savon à vaisselle et une éponge. Essuyer avec un linge sec.

Si la casserole est déformée ou si la surface anti-adhésive est usée, il est recommandé de se procurer une nouvelle casserole chez un détaillant et de remplacer l'ancienne casserole par la nouvelle.

C D Détecteur de casserole et plaque chauffante

Au besoin, nettoyer avec un chiffon humide.

E Capuchon de rétention d'humidité

Tirer vers l'extérieur pour enlever le capteur d'humidité (1). Le laver à l'eau et l'essuyer pour enlever toute humidité (2). Essuyer l'intérieur de l'orifice avec un linge humide (3). Fixer correctement le capteur en le poussant dans l'orifice (4).

F Accessoires

Laver avec du savon à vaisselle et une éponge. Rincer, puis essuyer.

If rice is not cooked well

Problem	Possible Cause (Reference page)
Rice boils over.	<ul style="list-style-type: none">● The amount of rice was not measured with the measuring cup provided with the rice cooker. (☞ Page 15) → The amount of rice cannot be measured correctly with a measuring rice bin or other methods.● The water level was not adjusted correctly.● Rice was not washed and rinsed thoroughly until water ran clear. (☞ Page 15)● The moisture retaining cap was not used. (☞ Page 15)
Rice is hard/soft/ half-boiled.	<ul style="list-style-type: none">● Rice may be cooked hard or soft depending on the type of rice or the storage period. Newer rice crop has more moisture so slightly less water than usual should be used when cooking.● Adjust the water level according to your preference.● The amount of rice was not measured with the measuring cup provided with the rice cooker. (☞ Page 15)● The water level was not checked against the gauges on both sides of the pan.● The menu key was not set correctly. (☞ Page 19)● Rice mixed with various ingredients and seasonings was cooked using the timer cooking function. (☞ Page 29)● Foreign substances stuck to the outside surface of the pan, the pan sensor or the heating plate. (☞ Page 31)● Rice may be cooked hard when cooked in the “Quick” menu.
Rice is scorched. (A light brown layer of rice at the very bottom of the pan is normal.)	<ul style="list-style-type: none">● Rice was not washed and rinsed thoroughly until water ran clear. (☞ Page 15)● Rice mixed with various ingredients and seasonings was cooked.● Foreign substances stuck to the outside surface of the pan, the pan sensor, or the heating plate. (☞ Page 31)● The pan was not washed thoroughly. → Wash the pan carefully especially after cooking mixed rice.

Problem	Possible Cause (Reference page)
<p>Porridge becomes gluey.</p>	<ul style="list-style-type: none"> ● Porridge may become gluey if the timer function is used to cook it. ● Do not use the keep warm function for porridge.
<p>Rice is dry.</p>	<ul style="list-style-type: none"> ● The moisture retaining cap was not used. (☞ Page 15) ● Rice was kept warm for longer than 12 hours. (☞ Page 21) ● The outer lid was not closed completely, permitting steam to escape and cause rice to become dry.
<p>Rice is discolored/smells.</p>	<ul style="list-style-type: none"> ● Rice was not washed and rinsed thoroughly until water ran clear. (☞ Page 15) ● The pan was not washed thoroughly. → Wash the pan carefully especially after cooking mixed rice. ● Rice was not fluffed (mixed) within 30 minutes after cooking was finished. (☞ Page 19) → Fluff (mix) rice to prevent its surface from becoming dry. ● Rice was kept warm for longer than 12 hours. (☞ Page 21) ● Cold rice was added to warm rice. ● Rice scoop was left in the pan while rice was kept warm. ● Mixed rice was kept warm. (☞ Page 21) ● Rice was repeatedly reheated. (☞ Page 23) ● The rice cooker was turned off.

Troubleshooting (Check the following items before you contact your retailer or service center.)

Problem	Possible Cause (Reference page)
<ul style="list-style-type: none"> ● Rice is not cooked at a preset time. 	<ul style="list-style-type: none"> ● The [Start] key was not pressed.
<ul style="list-style-type: none"> ● Cooking started as soon as timer cooking was activated. 	<ul style="list-style-type: none"> ● The timer was set to a time shorter than the minimum time required for cooking. (☞ Page 29) → Cooking starts upon activation of the timer cooking function under such conditions.
<ul style="list-style-type: none"> ● Key functions were disabled. ● Pressing the [Start] key did not activate the cooking function. 	<ul style="list-style-type: none"> ● The rice cooker was disconnected from an electrical outlet. ● The [Start] key was pressed while the [Keep Warm/off] lamp was lit.
<ul style="list-style-type: none"> ● Steam escaped from other than the steam vent. 	<ul style="list-style-type: none"> ● The packing of the lid or the brim of the pan was deformed or rice was stuck to them.
<ul style="list-style-type: none"> ● Power failed while the rice cooker was in operation. 	<ul style="list-style-type: none"> ● The cooking finishing time may be delayed. ● Cooking may not be done properly depending on the length of power failure.
<ul style="list-style-type: none"> ● The rice cooker produced sounds while the unit was in the cooking or the keep warm mode. 	<ul style="list-style-type: none"> ● Clicking sounds are produced by power adjustments. ● Popping sounds are produced when bursts of steam escape from between the pan and the heating plate. Over time this will damage the heater and pan, so it is important to keep them dry before using the unit.
Error Code	Possible Cause
<ul style="list-style-type: none"> 2 or 3 indication lamps flash together 	<ul style="list-style-type: none"> ● Consult your nearest retailer or service center for repair.

- * Replace damaged or deformed pan.
- * Consult your nearest retailer or service center if rice, water or other material is put directly into the main unit without using the pan.
- * The marks (●, ●) above the **[Start]** and the **[Keep Warm/Off]** keys are for blind people.

Specifications

Model		SR-LE10	SR-LE18
Power Supply		120 V AC	
Power Consumption (Approx.) W	Cooking	590	835
	Keeping Warm	84 (26*1)	95 (28*1)
Cooking Capacity L (cups)	White Rice	0.18~1.0 (1~5.5)	0.54~1.8 (3~10)
	Mixed Rice	0.18~0.54 (1~3)	0.54~1.08 (3~6)
	Thick Porridge	0.09~0.27 (0.5~1.5)	0.18~0.54 (1~3)
	Thin Porridge	0.09~0.18 (0.5~1)	0.09~0.36 (0.5~2)
Power Cord Length m (ft)		0.9 (3)	0.9 (3)
Weight (Approx.) kg		2.7 (5.9 lbs.)	3.4 (7.5 lbs)
Dimensions (Approx.) cm	Width	23.4 (9.2")	26.3 (10.4")
	Depth	32.1 (12.6")	35.1 (13.8")
	Height	20.1 (7.9") 39.6*2 (15.6**2)	23.2 (9.1") 45.2*2 (17.8**2)

*1: Average power consumption in the keep warm mode in a stable condition (at a room temperature of 20°C or 68°F)

*2: Height with the outer lid open

- Power consumption is approximately 2W when the rice cooker is turned off.

For further assistance contact Panasonic at: 800-211-PANA (7262) or visit our website at www.panasonic.com

Spécifications

Modèle		SR-LE10	SR-LE18
Alimentation		120 V c.a.	
Consommation (approx.) W	Cuisson	590	835
	Température de service	84 (26*1)	95 (28*1)
Capacité en L (tasses)	Riz blanc	0,18~1,0 (1~5,5)	0,54~1,8 (3~10)
	Riz mélangé	0,18~0,54 (1~3)	0,54~1,08 (3~6)
	Porridge épais	0,09~0,27 (0,5~1,5)	0,18~0,54 (1~3)
	Porridge léger	0,09~0,18 (0,5~1)	0,09~0,36 (0,5~2)
Longueur du cordon m (pi)		0,9 (3)	0,9 (3)
Poids (approx.) kg		2,7 (5,9 lb)	3,4 (7,5 lb)
Dimensions (approx.) cm	Largeur	23,4 (9,2 po)	26,3 (10,4 po)
	Profondeur	32,1 (12,6 po)	35,1 (13,8 po)
	Hauteur	20,1 (7,9 po) 39,6*2 (15,6 po*2)	23,2 (9,1 po) 45,2*2 (17,8 po*2)

*1 : Consommation d'énergie moyenne en mode maintien à la température de service
(à une température ambiante de 20°C ou 68°F)

*2: Hauteur avec le couvercle extérieur ouvert

- La consommation d'énergie est d'environ 2 W lorsque le contact est coupé sur le cuiseur de riz.

Pour obtenir de l'aide, composez le 800-211-PANA (7262) ou visitez notre site Internet à www.panasonic.com

Recipes

STEAMING VEGETABLES

1. Pour water into the rice cooker pan.
2. Place the steaming basket inside the pan.
3. Add vegetables (place in a dish if required).
4. Close the lid and plug in the power cord.
5. Select "Steam" and set the "Cooking time".
(refer to the table below)
6. Stir the vegetables occasionally and continue cooking until the "Cooking time" is complete.

Vegetable	Quantity	Time (minute)
Artichokes : Globe : Whole : Jerusalem : Peeled, Whole	2-4 2-4	30-40 15-20
Asparagus	8 oz. (200N)	5-10
Beans : Green waxed, whole	1 lb. (500N)	10-12
Broccoli : Spears	1 lb. (500N)	5-10
Beets : Whole	1 lb. (500N)	30-35
Carrots : Small, whole	1 lb. (500N)	10-12
Cauliflower : Flowerettes	1 lb. (500N)	12-14
Corn on the Cob	3-6 ears	10-13
Peas : Shelled	8 oz. (200N)	6-8
Potatoes, Sweet Potatoes, Quartered	5 oz. (140N)	20-25
Summer Squash, Zucchini : Cut-up	1 lb. (500N)	5-10
Winter Squash : Pieces	1 lb. (500N)	20-30
Acorn Squash : Half	1 lb. (650N)	17-20
Spinach	5 oz. (150N)	6-8
Frozen Mixed Vegetables	10 oz. (300N)	6-8

Panasonic Consumer Electronics Company,
Division of Panasonic Corporation of America
One Panasonic Way, Secaucus, New Jersey 07094

Matsushita Electric Industrial Co., Ltd.
Osaka 542-8588, Japan

Printed in Malaysia

RZ19A393
M0109P1093