

This Owner's Manual is provided and hosted by [Appliance Factory Parts](#).

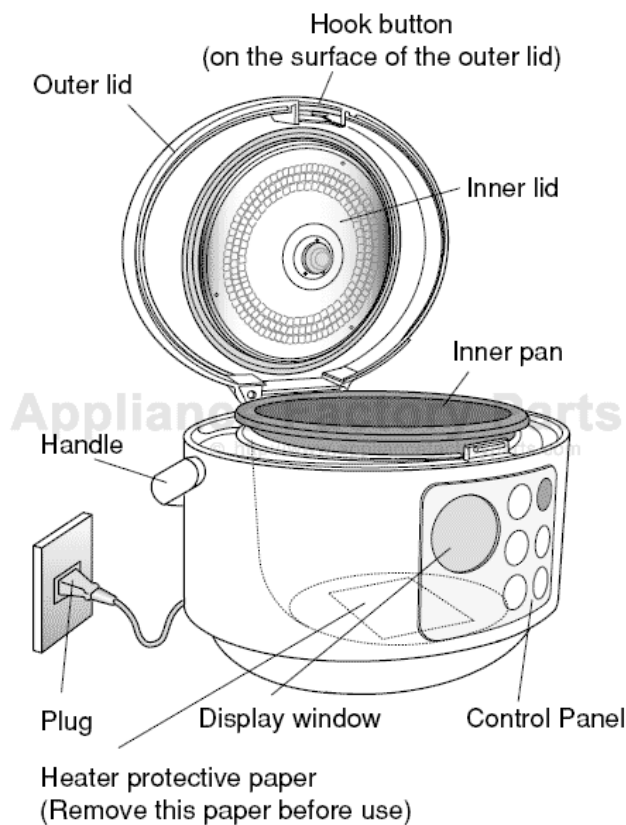

PANASONIC SR-YB05 Owner's Manual

[Shop genuine replacement parts for PANASONIC SR-YB05](#)



[Find Your PANASONIC Small Appliance Parts - Select From 148 Models](#)

----- Manual continues below -----

Electronic Rice Cooker/Warmer
 Cuiseur de riz / réchaud électronique
 微電腦電子鍋
 전자 밥솥

Operating Instructions
 Manuel d'utilisation
 使用說明書
 취급설명서

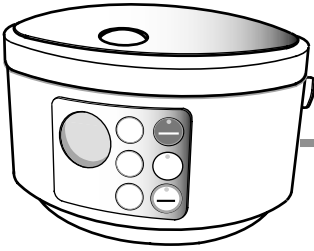

Model No. N° de modèle 型號 품번
SR-YB05

- Thank you for purchasing the Panasonic Electronic Rice Cooker/Warmer.
- For optimum performance and safety, please read these instructions carefully. Keep these Operating Instructions for further reference.
- Nous vous remercions d'avoir arrêté votre choix sur ce cuiseur de riz / réchaud électronique Panasonic.
- Pour un rendement optimal, nous vous recommandons de lire attentivement le présent manuel. Conserver ce manuel pour référence ultérieure.
- 非常感謝您購買我們的電子鍋。
- 為確保最佳的操作性能及用戶安全，請仔細閱讀以下指示。請保存此說明書作為進一步的參考。
- 이번에 Panasonic 전자 밥솥을 구매하여 주셔서 대단히 감사하는 바입니다.
- 사용자의 안전을 보호하고 제품의 성능을 최대한으로 즐기기 위하여, 본 취급설명서를 주의 깊게 읽어 주십시오. 본 설명서는 향후의 참고자료로서 잘 보관하여 주십시오.

Contents	Table des matières	目錄	차례
Important Safeguards 1	Consignes importantes 2		
Precautions 3	Précautions à prendre .. 4	安全注意事項 5	안전상의 주의 6
Parts Identification 7	Nomenclature 12	零件名稱 17	각부의 명칭과 사용방법 22
Preparation for Cooking Rice 8	Préparatifs à la cuisson du riz 13	準備炊飯 18	취사 준비 23
Cooking Rice 9	Cuisson du riz 14	炊飯 19	밥짓기 24
Timer Cooking 10	Cuisson par minuterie 15	預約定時 20	예약취사 25
Reheating Rice 11	Réchauffage du riz 16	再加熱 21	재가열 26
Adjusting the current time 11	Réglage de l'horloge .. 16	調整現在時間 21	현재의 시간 조정하기 .. 26
Cleaning and Maintenance 27	Nettoyage et entretien 28	清洗與保養 29	손질방법 30
Troubleshooting 31	Guide de dépannage .. 33	是否出了故障? 35	고장인가? 37
Specifications 39	Spécifications 39	規格 39	사양 39

IMPORTANT SAFEGUARDS

When using electrical appliances, basic safety precautions should always be followed, including the following:

1. Read all instructions.
2. Do not touch hot surfaces. Use handles or knobs.
3. To protect against electrical hazards do not immerse cord, plugs, and Rice Cooker, except pan, in water or other liquid.
4. Close supervision is necessary when any appliance is used by or near children.
5. Unplug from outlet when not in use and before cleaning. Allow cooling before putting on or taking off parts.
6. Do not operate any appliance with a damaged cord or plug or after the appliance malfunctions, or has been damaged in any manner. Return appliance to the nearest authorized service facility for examination, repair or adjustment.
7. The use of accessory attachments not recommended by the appliance manufacturer may be hazardous.
8. Do not use outdoors.
9. Do not let cord hang over edge of table or counter, or touch hot surfaces.
10. Do not place on or near a hot gas or electric burner, or in a heated oven.
11. Extreme caution must be used when moving an appliance containing hot oil or other hot liquids.
12. Always attach plug to appliance first, then plug cord into the wall outlet. To disconnect, turn any control to "off", then remove plug from wall outlet.
13. Do not use appliance for other than intended use.
14. This product is intended for household use.

SAVE THESE INSTRUCTIONS

NOTE

- A. A short power supply cord (or cord set) is provided to reduce the hazards resulting from becoming entangled in or tripping over a longer cord.
- B. Longer cord set or extension cords are available and may be used if care is exercised in their use.
- C. If a long cord set or extension cord is used,
 - (1) the marked electrical rating of the cord set or extension cord should be at least as great as the electrical rating of the appliance.
 - (2) if the appliance is of the grounded type, the extension cord should be a grounding-type three-wire cord, and
 - (3) the longer cord should be arranged so that it will not drape over the countertop or tabletop where it can be pulled on by children or tripped over accidentally.

This appliance has a polarized plug; (one blade is wider than the other). As a safety feature, this plug will fit into a polarized outlet only one way. If the plug does not fit fully into the outlet, reverse the plug. If it still does not fit, contact a qualified electrician. Do not attempt to defeat this safety feature.

Precautions



Warning

This sign warns of death or serious injury.



Caution

This sign warns of damage to property.

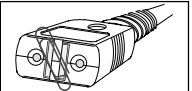

Warning

- **Properly plug into a wall outlet.**
(Improper plugging may cause electrical shock or fire due to heat generation.)
 - Do not use damaged plug or loose power outlet.
- **Do not cover the lid with your hand or place your face directly over the steam coming from the cooker. Be sure to keep this appliance away from the reach of children.**
(Placing your hand or face on the steam outlet may cause burns.)
 Steam outlet
- **Be careful not to let children lick the appliance plug.**
(Failure to do so may result in electrical shock or injury.)
- **Do not attach any metal piece such as a pin or any rubbish on the tip of the appliance plug (magnetic type).**
(Metal piece or rubbish on the plug may cause electrical shock or fire due to short circuit.)

- **Do not damage power cord or power plug.**
Never do the following to the power cord or power plug: disassembling, bringing near hot surfaces, bending, twisting, pulling, placing heavy objects on top, tying up in a bundle. Consult your nearest retailer or repair center for repairs.
 - (Using damaged power cord or plug may cause electrical shock or fire due to short circuit.)
- **Remove the dust on the power plug regularly.**
(Accumulated dust may contain moisture and cause fire due to insulation failure.)
 - Unplug the power supply and wipe off the dust with a dry cloth.
- **Do not use the power cord or power plug if damaged or when the power outlet is loose.**
(Metal pieces or rubbish on the plug may cause electrical shock or fire due to short circuiting.)
- **Do not use this appliance in any manner that exceeds the ratings of outlet or wiring instruments. Make sure the voltage of the unit is the same as your local supply.**
(Exceeding the ratings by sharing the outlet, etc. may cause fire due to heat generation.)
- **Do not allow children to use this appliance without close supervision by an adult. Keep the appliance out of reach of children when cooking.**
(Failure to do so may result in burns or injury.)
- **Never attempt to disassemble, take apart or repair.**
(These actions may cause fire, electrical shock or injury.)
 - Consult your nearest retailer or repair center for repairs.
- **Do not plug or unplug the rice cooker with wet hands.**
(May result in electrical shock.)
- **Do not immerse the unit in water or expose it to water.**
(May result in shorting or electrical shock.)
 - If water enters the main unit, consult your nearest retailer or service center.

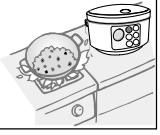

Caution

- **Do not expose to water, high humidity or heat sources.**
(Electrical shock, short circuit or fire may occur.)
- **Do not touch hot surfaces when in use or immediately after using.**
Especially be careful not to touch the inner side of the lid.
(Placing your hand or face on the steam outlet may cause burns.)

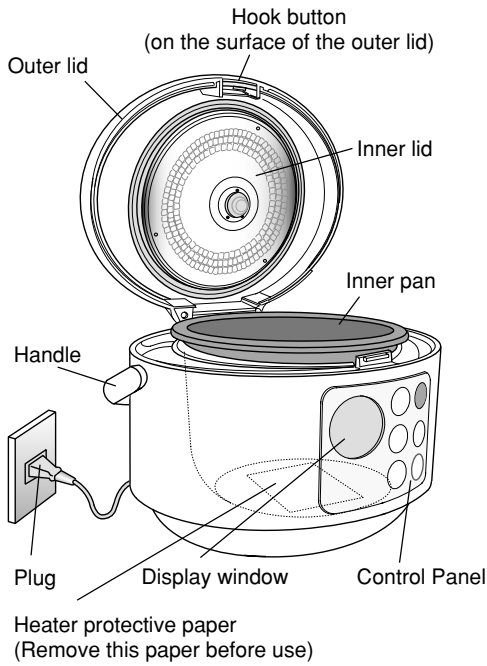
- **Allow the appliance to cool before cleaning.**
(Touching hot surfaces may cause burns.)
- **Be sure to hold the power plug to disconnect it.**
(Failure to do so may result in electrical shock or short circuit and it may cause fire.)
- **Do not use this appliance on an unstable surface or anything weak to heat.**
(The appliance may overturn and this may cause injury or fire.)
- **Do not insert anything other than the specified inner pan in the appliance.**
(Burns due to overheating or injury due to malfunction may occur.)
- **Do not touch the hook button when moving this appliance.**
(The lid will open and this may cause burns.)
- **Unplug from outlet when not in use.**
(Electrical shock due to deteriorated insulation or fire due to short circuit may occur.)
- **Do not use near a wall or furniture.**
(Steam or heat from this appliance may damage, discolor or deform the wall or furniture.)
 - If the appliance is placed on a cabinet, it is important to make sure that the steam coming from the unit can be properly vented.
- **Do not use other than the provided cord set (power plug and appliance plug). Do not use the cord set for other appliances.**
(Electrical shock, short circuit or fire may occur.)
- **Keep the outside of the inner pan and the pan sensor clean and dry.**
(Any foreign substance may cause the rice cooker to malfunction.)
- **Be sure to turn off the power with the [Warm/Off] key before removing the plug from the outlet.**
- **Be sure to turn off the power with the [Warm/Off] key before removing the inner pan.**

Parts Identification

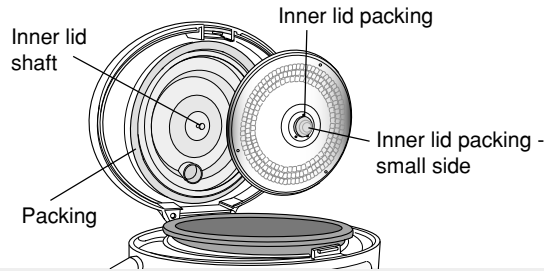

How to attach the inner lid

- ① Hold the inner lid with the small side of the inner lid packing facing you.
- ② Insert the large side of the inner lid packing on the inner lid shaft.



How to remove the inner lid

The inner lid comes off by holding the side of the inner lid with your fingers and pulling the lid towards you.

Accessories

Measuring cup
(Approx. 180 ml)



Rice scoop

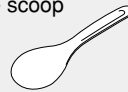

Detachable Cord
(plug)



(Appliance plug)

Control Panel

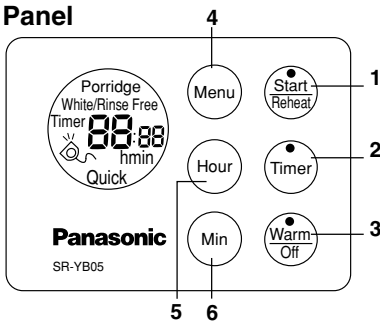

1.	Start/Reheat	Starts cooking, timer cooking or reheating.
2.	Timer	Sets the timer
3.	Warm/Off	Turns on/off the keep warm function. Turns off the timer function. Cancels preset operation.
4.	Menu	Selects a cooking menu.
5.	Hour	Adjust hours. Sets hours for timer cooking.
6.	Min	Adjust minutes. Sets minutes for timer cooking.

To avoid damage to non-stick coating on the inner pan

Do not knock or scratch the inner pan.



- Do not use vinegar.
- Wash the inner pan immediately after cooking rice with seasoning (e.g., mixed rice).

Do not place any spoon or tableware inside the inner pan.



- Do not rinse the rice with objects such as whisks.
- Do not use metal utensils or sharp objects which may damage the inner pan surface.

Do not wash the inner pan with cleansing powder, metal scrubs or nylon scrubs.

Wash with sponge



Information

About external surface coating of the inner pan

A part of the coating may come off from the bottom or outer surface of the inner pan when the inner pan is used frequently, but the performance of the inner pan will not be affected.

Coating from the bottom or outer surface may come off

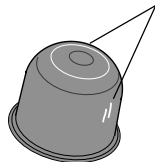

Notice about Initial Use

There may be a resin smell when the unit is first used. This will go away with additional uses.

Preparation for Cooking Rice

1

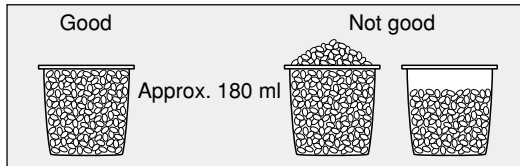

Measure rice with the measuring cup provided

- When using other than the measuring cup provided, a cup of 180 ml must be used.

2

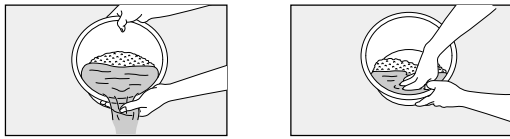

- ① Pour sufficient amount of water on the rice and stir the rice and water. Drain the water quickly.

- ② Rinse the rice until water becomes relatively clear.

Rinse the rice

- Rinse the rice in a container other than the inner pan.
- Rinse the rice at least 3 times or until the water drains fairly clearly. Insufficient rinsing may result in boiling over, more browned rice than usual or rice bran smell.
- Do not leave the rice on the colander after it is drained. Otherwise, the rice may be cracked and become too sticky when cooked.

3

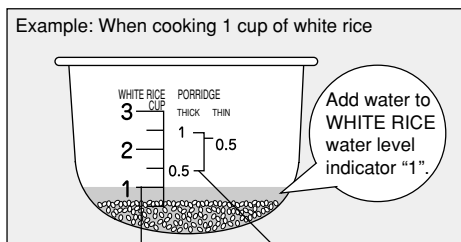

Water level indication for "white rice, rinse-free rice and mixed rice"

Porridge water level indication (THICK: thick porridge, THIN: thin porridge)

Add water according to the water level indication of the selected menu

- Add water after placing the pan on a flat surface.
- Do not use hot water or alkaline ionized water of pH9 or higher. (Cooking with these types of water may result in rice yellowing or becoming too sticky.)
- When cooking rice mixed with barley or rinse-free rice, adjust the water level to slightly higher than water level indication for white rice.
- Adjust the water amount to your taste.

4

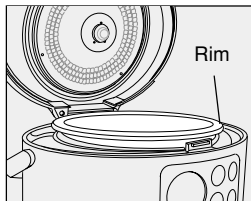

Place the inner pan in the body and close the outer lid

- Wipe off water or any foreign material on the outer surface, rim and bottom of the inner pan. (Water or foreign material on the pan may cause steam leakage or sounds of water drops popping. Also, rice may not be cooked properly.)

5

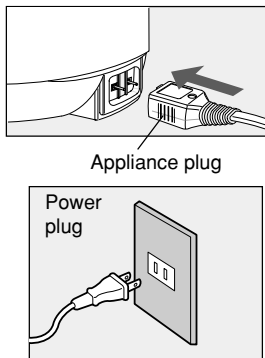

- Attach the plug to the appliance. Connection on the appliance is located in the right rear side if looking at the appliance from its front side.
- Plug the cord into a wall outlet.

Attach the appliance plug to the appliance and plug the cord into a wall outlet.

Information

About rinse-free rice

- Rinse-free rice does not require rinsing before cooking. However, the instructions stated below must be followed.
- Rice bran has already been removed from rinse-free rice, thus the amount of rinse-free rice will be more than usual if it is measured with the measuring cup provided.
 - Add slightly more water than usual to see how the rinse-free rice is cooked. Then adjust the amount of water to suit your taste in the future.
- Rinse-free rice sometimes does not mix well with water.
 - Stir from the bottom gently before cooking. When water is added, the water will become slightly whitish due to dissolved starch from the rice. If rice becomes more brownish than usual or there is an unpleasant smell, rinse the rice slightly with water.

Cooking Rice

1

Selecting the desired menu

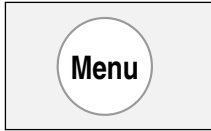

(Menu selected will blink.)



Pressing the **[Menu]** key changes the menu that is selected. Selected menu will blink.

"White/Rinse Free"
↓
"Quick"
↓
"Porridge"
↓
"White/Rinse Free"

2

Press the **[Start/Reheat]** key

[Start/Reheat] lamp lights up when cooking starts.



The unit displays the remaining time from 13 minutes before cooking is complete.



	Time until cooking is complete (Approx.)	Using of keep warm mode	Remaining time until cooked is shown on display at:
White/Rinse Free	46 – 55 min.	○	13 min.
Mixed Rice	50 – 60 min.	×	
Quick Cook	29 – 42 min.	○	10 min.
Porridge	59 – 65 min.	×	5 min.

3

Fluff the rice as soon as possible after the beep sounds.

[Warm/Off] lamp lights up and warming starts automatically.

- It is not necessary to let the rice stand after it is cooked.

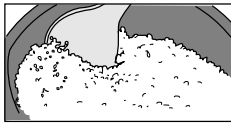

The display will show the elapsed keep warm time hourly for up to 23 hours. After 23 hours the display will reset and count up another 24 hours. The keep warm mode will automatically turn off after 96 hours.



- When the inner pan becomes empty → Press **[Warm/Off]** and unplug the power supply.

- Be sure to press the **[Warm/Off]** key to stop the keep warm function. If the keep warm function is interrupted by unplugging the cord, the unit will automatically be set to keep warm mode when plugged in the next time.

Information



- For best results, do not use the keep warm feature for more than 12 hours.
- It is not unusual if there is condensation on the inner lid when the keep warm mode is used.
- When only a small amount of rice is being kept warm, gather the rice into the center of the inner pan and occasionally fluff it or sprinkle in a small spoonful of water (approx. 1 tsp (5cc)) per bowl of rice to avoid excess drying.
- When cooking mixed rice, use the "White/Rinse Free" menu.
Do not use keep warm mode for mixed rice to avoid odours or spoiling of the rice.
- Do not use keep warm mode for porridge to avoid porridge from becoming like paste.
- When using "Quick Cook", the rice may be a little firmer and more brownish than usual.
- Do not use "Quick Cook" for "Mixed Rice".

Timer Cooking

- Make sure that the currently indicated time is correct. (see page11)

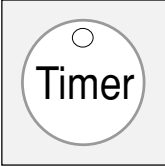
Example: When the rice should be ready at 6.30 p.m.

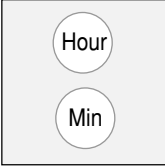

1  **Press [Timer] key**

 [Start/Reheat] lamp blinks. 

2  **Press [Hour] and [Min] to set the time you would like the rice/porridge to be ready.**

Time will be memorized for future use.  

3  **Press [Start/Reheat] key**
→ Timer has been set.
 ([Timer] lamp lights up)
 When rice cooking starts immediately after setting the timer → See page 31.

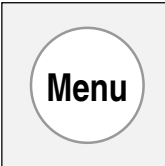

■ To set the timer for porridge, after carrying out steps **1** and **2** above :

3  **Press [Menu] key to select "Porridge".**

 "Porridge" indicator blinks.

4  **Press [Start/Reheat] key**
→ Timer has been set.
 ([Timer] lamp lights up)

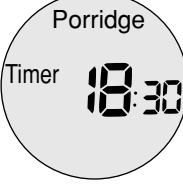
■ When changing or canceling the timer setting, press [Warm/Off] key.

Information

- Time set will not be put in the memory unless the [Start/Reheat] key is pressed.
- Menus that cannot be cooked properly with the timer mode → Menu using seasoning or ingredients other than rice.
- Timer cooking function cannot be used for "Quick Cook".
- Allowable timer settings → From 1 hour, 10 minutes up to 24 hours from the current time. However, the maximum of 13 hours is recommended for the timer cooking function to avoid deterioration of ingredients. (In summer, 8 hours is the recommended limit because the water temperature may be higher.)
- When cooking with Timer, rice may become softer or more brownish than usual.
- When cooking porridge with Timer, the porridge may become a little like a paste.

Reheating Rice



Reheat function can be used only when the **[Warm/Off]** lamp is lit.

Press **[Start/Reheat]** key

[Warm/Off] lamp starts blinking.

When approximately 5 minutes have elapsed since the start of reheating, a short beep will sound and the lamp is lit. Then, fluff the rice.

※ Reheat function cannot be used if the temperature of the rice is 106°F (50°C) or below. In this case, a long beep sounds 4 times if the key is pressed.

Adjusting the current time

Example: When adjusting from 6:59 a.m. to 8:30 a.m.

- ① Insert the appliance plug and the power plug.

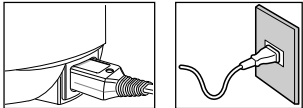

- ② Press **[Hour]** or **[Min]** for 1 second or longer.
(After a beep sound, release the key, the Hour and Minute starts blinking.)

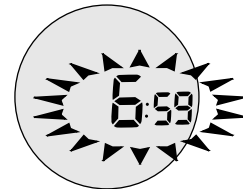

- ③ Press **[Hour]** key to set to "8".
Press **[Min]** key to set to "30" to set to "8:30".



(The current time setting is completed when the time display is lit after blinking for 5 seconds.)

- ※ The time cannot be set while cooking, keeping warm or using the timer cooking function.
- ※ Press the **[Hour]** or **[Min]** key continuously for fast forwarding.
- ※ The time is displayed on 24-hour base. Set 0:00 for 12 o'clock midnight and 12:00 for 12 noon.

When the appliance plug comes off or power failure occurs

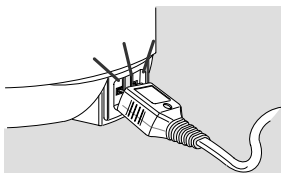

※ When the appliance plug is disconnected accidentally or power failure occurs while using the rice cooker/warmer (during cooking, keep warm or timer cooking), a short beep will sound 3 times and the indication shown on the right will appear on the display window.

※ If the appliance plug is disconnected while using the rice cooker/warmer, please plug in again immediately. The operation immediately before the power supply was interrupted will be continued automatically, but the rice may not be cooked properly or the temperature of the rice warmed may drop depending on the conditions.

※ The above indication will not go off even after inserting the appliance plug to resume power supply, but the operation will not be affected. The indication will go off when the **[Warm/Off]** key is pressed once cooking rice or keeping warm is completed.

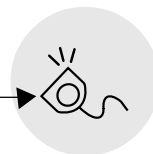

Cleaning and Maintenance

Remove the dirt or foreign material from the unit following the procedures below.

- Be sure to remove the power plug and carry out these operations when the unit is cold.
- Do not use objects such as benzene, thinner, cleansing powder or metal or nylon scrubs.

Rice cooker unit

Wipe with a firmly wrung wet cloth.

Note

- Do not use kitchen detergent.
- Wipe clean the area around the steam outlet if there is any yellowing after using chemical additives or rice improvers during cooking.
- Wipe the recessed area clean with a dry cloth after every use.

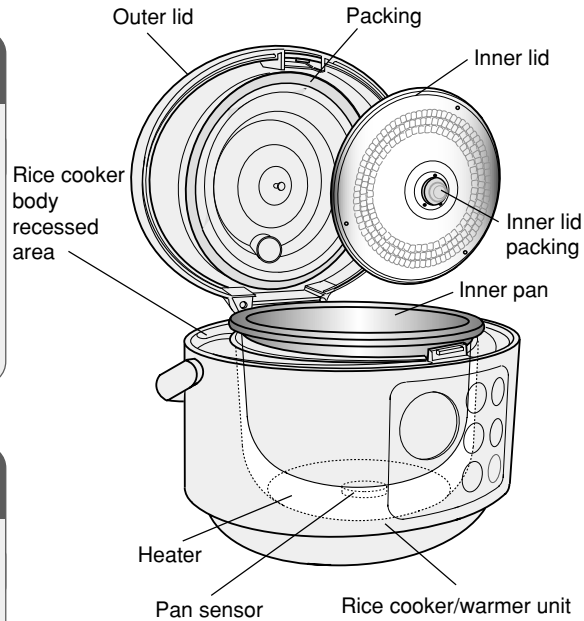

Pan Sensor and Heater

If any object gets stuck to the pan sensor or heater, lightly polish it off with a nylon scrub containing a small amount of synthetic detergent. Then, wipe with a firmly wrung cloth.

Inner pan

Wash with diluted kitchen detergent (synthetic) and sponge. Color of the inner pan may become uneven as it is being used, but the performance or safety will not be affected.

Note

Replace the inner pan if its non-stick coating comes off (harmless) or it becomes deformed. Inner pan can be purchased from the Panasonic Parts Center.

Inner lid

Wash with diluted kitchen detergent and sponge, then attach it to the outer lid with the small side of the inner lid packing facing you. (See page 7 for details.)

If dirt cannot be cleaned even after carrying out the above, use the detergent containing cleanser that will not damage stainless steel, then wipe with a cloth or sponge.

Accessories

Wash with diluted kitchen detergent and sponge.

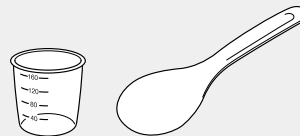



Troubleshooting

Please check the following before consulting your nearest service center.

Symptoms	Please check	See page
[Start/Reheat] key does not function.	<ul style="list-style-type: none"> ● Is "U14", "H01" or "H05" indicated on the display window? ● Is any lamp lit? → Key operation is not available when any lamp is lit. Press the [Warm/Off] key to turn off the lamp before the key operation. ● Make sure power cord is plugged in. 	See below – 8
Rice cooking starts immediately after setting the timer cooking.	<ul style="list-style-type: none"> ● Is the indicated current time correct? Is the time set correctly? → Time is displayed on 24-hour base. Please check the time once again. ● Is the time set within 1 hour 10 minutes from the current time? → If so, rice cooking starts immediately. 	11 10
Rice is not cooked at the set time.	<ul style="list-style-type: none"> ● Is the indicated current time correct? Is the time set correctly? → Time is displayed on 24-hour base. Please check the time once again. ● Make sure both plugs are plugged in. 	11 8
The rice cannot be reheated.	<ul style="list-style-type: none"> ● Is the keep warm function turned off? ● Is the rice too cold? (if the rice is cold, a beep sounds 4 times.) → Reheat function cannot be used if the temperature of the rice is approximately 106°F (50°C) or below. 	11 11
Steam leaks from under the outer lid.	<ul style="list-style-type: none"> ● Steam may leak if rice is stuck on the packing on the outer lid or rim of the inner pan or if the packing or rim of the inner pan becomes deformed. ● Deformation of the inner lid may result in steam leakage. 	– –
If power failure occurs or the appliance plug comes off during cooking rice.	<ul style="list-style-type: none"> ● The time it will be ready for eating may be delayed. ● The rice may not be cooked properly. 	– 11
A sound is heard while cooking rice or keeping warm.	<ul style="list-style-type: none"> ● Clicking sound: The sound of changing heating levels. ● Popping sound: The sound of water drops on the bottom (outside) of the inner pan expanding and bursting. 	– 8

When this indication is displayed

	<ul style="list-style-type: none"> ● Make sure both plugs are plugged in. → Insert the plugs. (This indication will remain on until the cooking function or keep warm function is complete even after the power supply is restored.) 	11
	<ul style="list-style-type: none"> ● The keep warm function has been on for more than 96 hours. → Press the [Warm/Off] key. 	9
	<ul style="list-style-type: none"> ● Consult your nearest service center for repairs. 	–

- There are special raised areas (● and ◐) on the [Start/Reheat] and [Warm/Off] keys for those who are visually impaired.
- If water or rice is put directly in the unit accidentally without placing the inner pan, consult your nearest service center.

Symptoms	Please check	See page
The rice boils over	<ul style="list-style-type: none"> ● If water is not added on the flat surface, the water amount will be more than the proper amount and this will result in boiling over. ● This is because too much water is added to make the rice softer. ● If the rice is measured with a rice container with measuring function, the rice amount may be lesser and this may result in boiling over. ● Rice is not rinsed sufficiently. (Water becomes rather sticky) ● Boiling over may occur when the appliance plug comes off while cooking porridge and the cooking is continued after inserting back the appliance plug. 	8 — 8 8 —
The rice is: <ul style="list-style-type: none"> ● too firm ● too soft 	<ul style="list-style-type: none"> ● If water is not added on the flat surface, the water amount will be more or less than the proper amount and this will result in too firm or too soft rice. ● Firmness or softness of rice varies depending on the brand, place of origin and storage period (new or old crop) of the rice. ● The rice will be softer than usual if it is cooked using the timer cooking function. ● The rice will be firmer than usual if it is cooked using the quick cook function. 	8 — 10 9
The rice (on the bottom of the inner pan) becomes browner than usual.	<ul style="list-style-type: none"> ● Because foreign material is attached on the bottom of the inner pan or sensor. ● Because mixed rice or rice with germ are cooked. ● The rice may become brown if it is cooked using the timer cooking function. 	3 — 10
The rice dries up.	<ul style="list-style-type: none"> ● Because the rice is kept warm for longer than 12 hours. ● Because the rice is reheated repeatedly. ● Because the steam is leaked from the gap of the outer lid. 	9 11 —
The rice: <ul style="list-style-type: none"> ● is discolored ● smells ● is wet with water condensation 	<ul style="list-style-type: none"> ● Because the rice was not fluffed immediately after cooked (Excess water results in condensation on the rice or too sticky rice.) ● Because the rice is kept warm for longer than 12 hours. ● Because the cool or cold rice is added during keeping warm. ● Because rice is not rinsed sufficiently. ● Cooked rice may look yellowish depending on the type of the rice or water. ● Wash the inner pan well after cooking mixed rice to avoid prolonged smell. ● There may be a smell when rinse-free rice is cooked. <p>→ Rinse the rice lightly before cooking.</p>	9 9 — 8 — — 8
Porridge becomes like a paste.	<ul style="list-style-type: none"> ● Because porridge is kept warm. 	9

■ **About lithium battery (when display is turned off)**

While being unplugged from the power supply, the clock is functioning with a lithium battery. Even if the lithium battery level becomes empty, the clock can still be used by plugging the cord and resetting the time. Regular replacement of lithium battery is not required. Consult your nearest sales outlet or repair center for replacing of lithium battery.

Model		SR-YB05
Power Supply		120V
Power consumed (Approx.) W	Cooking	280
	Keep warm	280 (23*)
Cooking capacity L (cups)	White Rice	0.09 - 0.54 (0.5 - 3)
	Mixed Rice	0.18 - 0.36 (1 - 2)
	Thick Rice Porridge	0.09 - 0.18 (0.5 - 1)
	Thin Rice Porridge	0.09 (0.5)
Cord Length m		1.0 (39.4")
Weight (Approx.) kg		1.9 (4.2 lbs)
Dimensions (H×W×D) (Approx.) cm		17.0 × 25.0 × 21.0 (6.7" × 9.8" × 8.3")

(*) Average power consumption in the keep warm mode in a stable condition (at a room temperature of 20°C or 68°F).

Modèle		SR-YB05
Alimentation		120V
Consommation (Approx.) W	Cuisson	280
	Maintien au chaud	280 (23*)
Capacité de cuisson L (tasses)	Riz blanc	0.09 - 0.54 (0.5 - 3)
	Riz mélangé	0.18 - 0.36 (1 - 2)
	Riz ou gruau épais	0.09 - 0.18 (0.5 - 1)
	Riz ou gruau clair	0.09 (0.5)
Longueur du cordon d'alimentation m		1.0 (39.4")
Poids (Approx.) kg		1.9 (4.2 lbs)
Dimensions (L×P×H) (Approx.) cm		17.0 × 25.0 × 21.0 (6.7" × 9.8" × 8.3")

(*) Consommation d'énergie moyenne en mode maintien au chaud (à une température ambiante de 20°C ou 68°F).

型號		SR-YB05
電源		120V
消費電力(大約) W	煮飯時	280
	保溫時	280 (23*)
米的容量 L (杯)	白飯	0.09 - 0.54 (0.5 - 3)
	什錦飯	0.18 - 0.36 (1 - 2)
	稀飯(稠)	0.09 - 0.18 (0.5 - 1)
	稀飯(稀)	0.09 (0.5)
電源線長度 m		1.0 (39.4")
重量(大約) kg		1.9 (4.2 lbs)
尺寸(高×寬×深)(大約) cm		17.0 × 25.0 × 21.0 (6.7" × 9.8" × 8.3")

(*) 在保溫模式平穩狀態下的平均電力消耗(在 20°C 或 68°F 室溫下)。

품번		SR-YB05
전원		120V
소비전력(약) W	밥지를 때	280
	보온시	280 (23*)
밥짓기 용량 L (컵)	쌀밥 (고속취반)	0.09 - 0.54 (0.5 - 3)
	섞어짓기	0.18 - 0.36 (1 - 2)
	된 쌀죽	0.09 - 0.18 (0.5 - 1)
	진 쌀죽	0.09 (0.5)
코드길이 m		1.0 (39.4")
질량(무게) (약) kg		1.9 (4.2 lbs)
크기(H×W×D) (약) cm		17.0 × 25.0 × 21.0 (6.7" × 9.8" × 8.3")

(*) 정상시 보온상태에서의 평균 소비전력 (실내온도가 섭씨 20 도 또는 화씨 68 도일 경우)

Customer Service Contact Information for USA (FOR USA AND PUERTO RICO ONLY)

If you need assistance with this product, please contact us in one of the following ways:

Product information, where to have this unit repaired:

Website: www.panasonic.com

Information on how to use this product or other product related questions:

Panasonic Customer Call Center: 800-211-PANA; M-F 9-9 ET & S-S9-7 ET

Purchasing replacement parts for this product:

Panasonic National Parts Center: 800-332-5368, M-F 9:00 a.m. to 8:00 p.m. ET

Matsushita Electric Industrial Co., Ltd.

Osaka 542-8588, Japan

Printed in Malaysia

Imprimé en Malaisie

RZ19A906

MO104PO