

This Owner's Manual is provided and hosted by [Appliance Factory Parts](http://www.appliancefactoryparts.com).

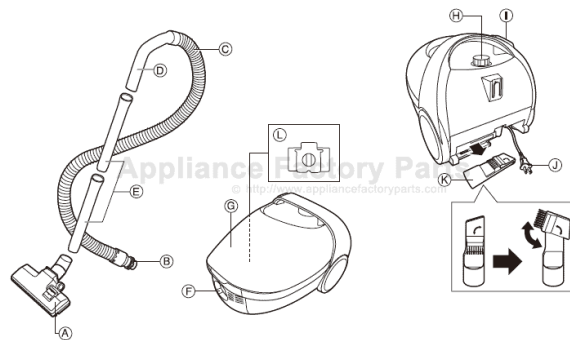

# PANASONIC MC-CG381 Owner's Manual

[Shop genuine replacement parts for PANASONIC  
MC-CG381](#)



[Find Your PANASONIC Vacuum Cleaner Parts - Select From 605 Models](#)

----- Manual continues below -----

Model No. **MC-CG381**

<b>Operating Instructions</b> Vacuum Cleaner	ENGLISH
<b>Instructions d'utilisation</b> Aspirateur	FRANÇAIS
<b>Manual de instrucciones</b> Aspiradora	ESPAÑOL

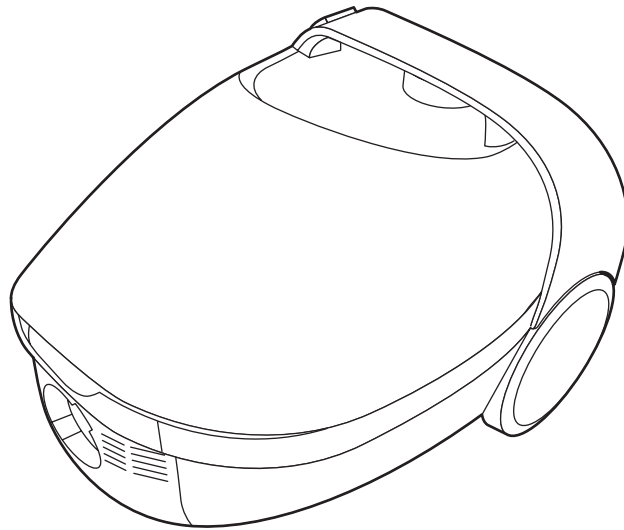

**en** Keep pages 3 and 10 open when reading this manual, to make easier identify the different parts of the product.  
We would recommend that you carefully study these Operating Instructions before attempting to operate the unit, and that you note the Important Safety Instructions .....

**Page 4**

**fr** En lisant ce mode d'emploi, gardez les pages 3 et 10 ouvertes pour identifier facilement les pièces. Avant de mettre en marche l'aspirateur, nous vous conseillons de lire attentivement ce Manuel d'Instruction pour le fonctionnement correct de l'appareil. ....

**Page 6**

**es** Mantenga las páginas 3 y 10 abiertas para una fácil identificación de las piezas cuando lea este manual. Antes de poner en marcha la aspiradora, le recomendamos que lea atentamente este Manual de Instrucciones para el correcto funcionamiento del aparato. ....

**Página 8**

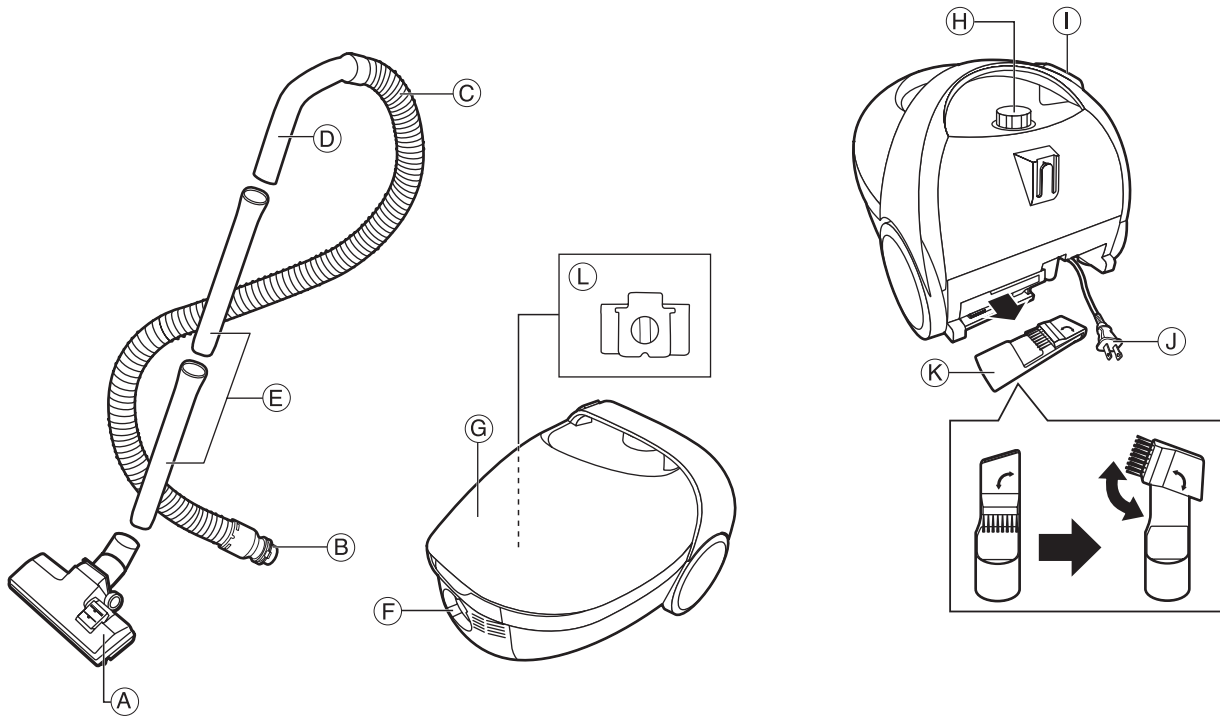
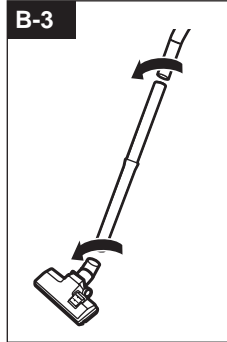
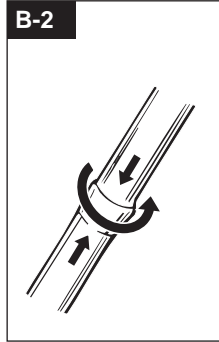
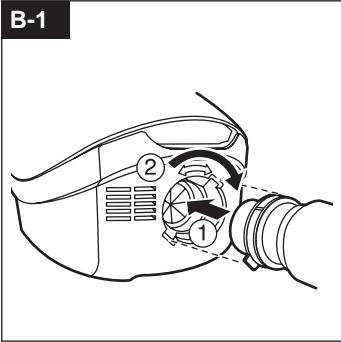
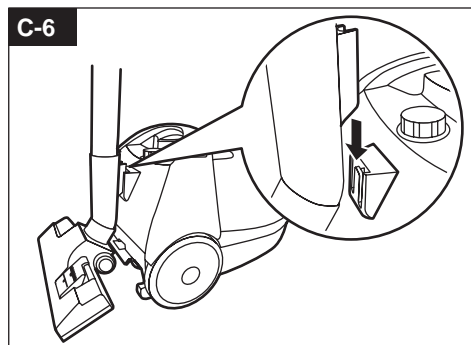
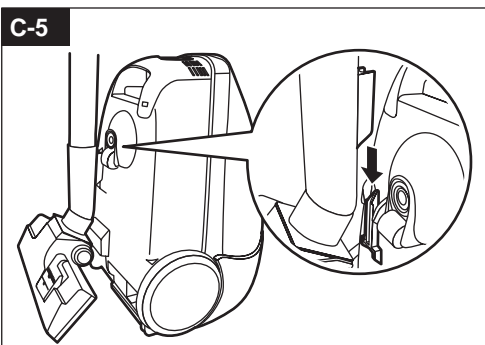
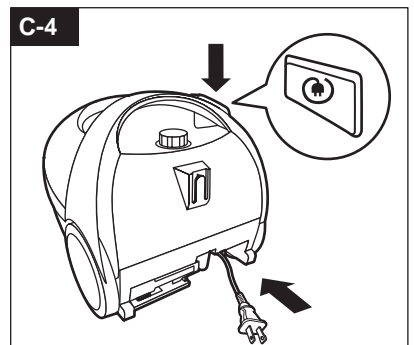
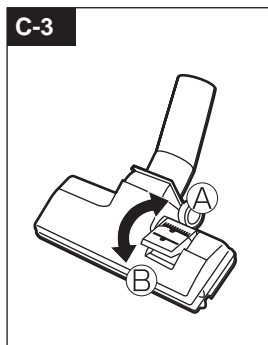
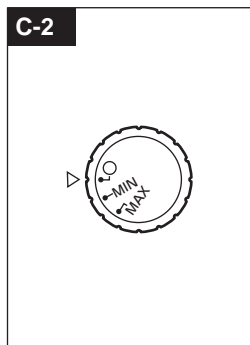
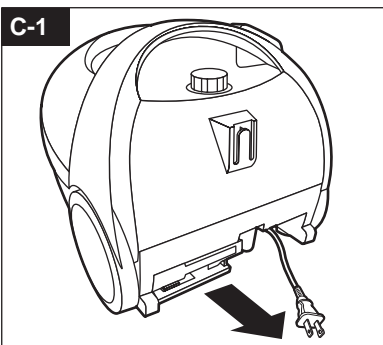

**A****B****C**

## IMPORTANT SAFETY INSTRUCTIONS

When using this vacuum cleaner, basic precautions should always be followed, including the following:

READ ALL INSTRUCTIONS BEFORE USING THIS VACUUM CLEANER

**⚠ WARNING** statements are designed to alert you to the possibility of injury, loss of human life, and/or damage to the vacuum cleaner and/or personal property if the instructions given are not followed.

**⚠ CAUTION** statements are designed to alert you to the possibility of damage to the vacuum cleaner and/or personal property if the instructions given are not followed.

### ⚠ WARNING

To reduce the risk of fire, electric shock, or injury:

- Do not leave vacuum cleaner when plugged in. Unplug from outlet when not in use and before servicing.
- Do not use outdoors or on wet surfaces.
- Do not allow to be used as a toy. Close attention is necessary when used by or near children.
- Use only as described in this manual. Use only manufacturer's recommended attachments.
- Do not use with a damaged cord or plug. If vacuum cleaner is not working as it should, has been dropped, damaged, left outdoors, or dropped into water, return it to a service center.
- Do not pull or carry by cord, use cord as a handle, close a door on cord, or pull cord around sharp edges or corners. Do not run vacuum cleaner over cord. Keep cord away from heated surfaces.
- Do not unplug by pulling on cord. To unplug, grasp the plug, not the cord.
- Do not handle plug or vacuum cleaner with wet hands.
- Do not put any object into openings. Do not use with any opening blocked; keep free of dust, lint, hair, and anything that may reduce air flow.
- Keep air, loose clothing, fingers, and all parts of body away from openings and moving parts.
- Do not pick up anything that is burning or smoking, such as cigarettes, matches or hot ashes.
- Do not use without dust bag and/or filters in place.
- Turn off all controls before unplugging.
- Do not use to pick up flammable or combustible liquids such as gasoline or use in areas when they may be present.
- Hold plug when rewinding onto cord reel. Do not allow plug to whip when rewinding.
- Do not use the cleaner to pick up sharp hard objects, small toys, pins, paper clips, etc. They may damage the cleaner or dust bag.
- Always change the dust bag after vacuuming carpet cleaners or freshener, powders and fine dust. These products clog the bag, reduce airflow and can cause the bag to burst. Failure to change bag could cause permanent damage to the cleaner.
- Use extra care when cleaning on stairs. Do not put on chairs, tables, etc. Keep on floor.

## SAVE THESE INSTRUCTIONS

THIS VACUUM CLEANER IS INTENDED FOR HOUSEHOLD USE ONLY

- To reduce the risk of electric shock, this vacuum cleaner has a polarized plug (on blade is wider than the other). This plug will fit in a polarized outlet only one way. If the plug does not fit fully in the outlet, reverse the plug. If it still does not fit, contact a qualified electrician to install the proper outlet. Do not change the plug in any way.

### Notice

Before you plug in your Panasonic Vacuum Cleaner, make sure that the voltage indicated on the rating plate located at the back of the vacuum cleaner is the same as your local supply.

### A- IDENTIFICATION OF MAIN PARTS

- A) Floor nozzle
- B) Connection pipe
- C) Hose
- D) Curved wand
- E) Extension wand
- F) Hose inlet
- G) Dust cover
- H) ON/OFF Switch / power control button
- I) Cord rewind pedal
- J) Plug
- K) Multipurpose accessory
- L) Paper dust bag

### B - HOW TO ASSEMBLE YOUR CLEANER

- B-1** Insert the connection pipe into the hose inlet and turn the pipe to the right.
- B-2** Connect the two extension wands by inserting one into the other and twisting together.
- B-3** Insert the curved wand into the upper end of the extension wand, and the floor nozzle to the other end.

## C - HOW TO OPERATE YOUR CLEANER

- C-1** Pull out the power cord and put the plug into the socket outlet.
- C-2 Power control**  
「O」: OFF  
You can turn the appliance ON by turning it to the clockwise direction.
- MIN:Lowest suction.  
MAX:Highest suction.
- C-3 Switching between carpet and flooring**  
Flooring: Press lever A  
Carpet: Press lever B
- C-4 After you finish vacuuming, remove the plug from the socket outlet and press the cord rewind pedal.**  
When rewinding the power cord, press the cord rewind pedal holding the plug so that it does not become damaged.
- C-5 Storage position**  
Slide the wand holder straight into the wand supporter.
- C-6 Park position**  
For short breaks during vacuuming, slide the wand holder into slot on the rear side of main body.  
**NOTE:** When you use park position, we suggest that you switch the appliance off.

## D - MAINTENANCE AND SERVICING

### ⚠ CAUTIONS

- The plug must be removed from the socket outlet before cleaning or maintaining the appliance.
- DO NOT use hot air or hot surface to dry filters. Dry them at room temperature for approximately 24 hours.
- **IMPORTANT:** Before re-installing the washable filters, make sure they are completely dry to avoid damaging the appliance.

**NOTE:** If the paper dust bag is not properly installed, the dust cover will not close. Be sure to check that the paper dust bag is properly installed before operating the appliance, otherwise dust will leak out.  
The dust bag can easily lay on the dust cover packing or clip between the bag collar and the body, so be sure to properly extend it into the body of the appliance.

### Replacing the paper dust bag

- D-1** Lift the dust cover catch and raise the dust cover until it clicks properly.
- D-2** Remove the bag collar from the bag holder and pull out the paper dust bag.
- D-3** Put in a new paper dust bag.
- D-4** Close the dust cover properly until you hear it click.

### Floor nozzle

- D-5** Inspect once a month.  
Using an old toothbrush or similar tool, clean any dirt or lint from the brush.

### Vacuum cleaner body

- D-6** Wipe with a soft cloth soaked with water.

### Maintaining the Pre-motor Filter

Follow the procedure written below when the suction power is not restored after replacing a new paper dust bag.

- D-7** Open the dust cover.
- D-8** Remove the pre-motor filter.
- D-9** Wash gently with water and then allow to dry in a shaded location.
- D-10 Return the pre-motor filter to its original position.**  
**NOTE:** Make sure you remember to replace the filter.  
If the filter is not installed, it will cause motor failure.
- Do not wash the filter in a washing machine or dry it with a dryer or other source of hot air.

### What to do if your cleaner does not work

Check that the appliance is correctly plugged in and that the socket outlet is working. If the thermal cut-out device has operated, wait until it resets automatically after approximately 60 minutes.

If after having checked the above mentioned points, the appliance does not work, take it to an Authorized Service Centre to be repaired.

### What to do when the suction performance reduces

- Stop the appliance and unplug from the socket outlet.
- Check whether the wands, hose and accessories are blocked or not. If they are blocked, remove the obstruction.
- Check whether the paper dust bag is full. If it is full, replace it.
- Check whether the pre-motor filter is blocked with dust. If they are blocked, clean them out or replace them.

## SPECIFICATIONS

	MC-CG381
Power source	120 V-60 Hz
Current	10 Amps
Dimensions (W x L x H)	240 mm x 350 mm x 250 mm
Net weight	3.8 kg
Extension wands	Metal x 2
Multipurpose accessory	√

### Optional Accessory

Product name	Model number
Paper dust bag (PACK 5/u.)	C-20E

### REMINDER FOR CUSTOMER

The model and serial number of this product may be found on the nameplate located on the underside of your appliance. You should note the model and serial number in the spaces provided and retain this book as a permanent record of your purchase.

Model Number. ....  
Serial No. ....  
Date Purchased. ....  
Where Purchased. ....

# D

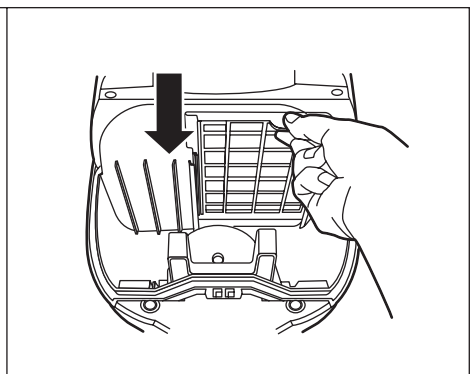
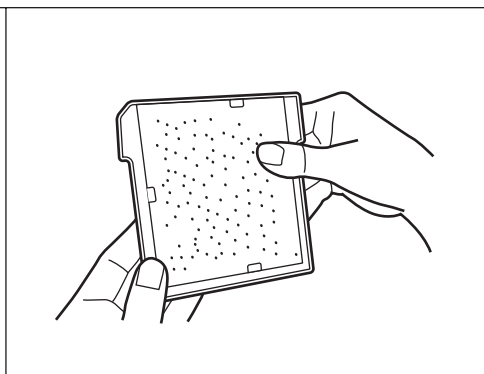
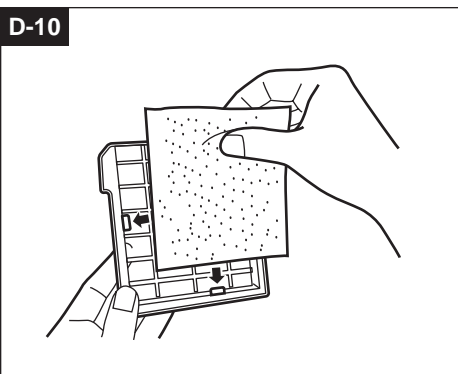
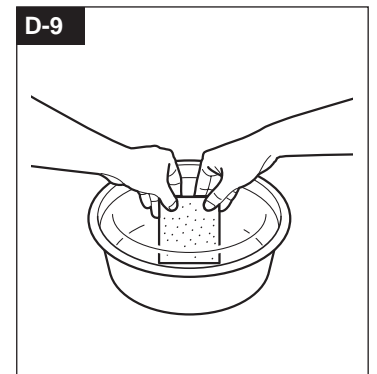
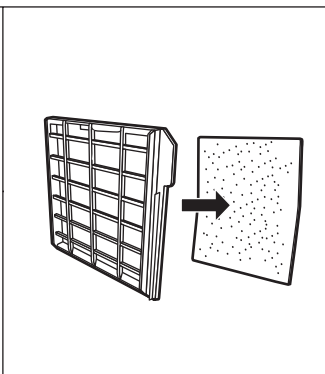
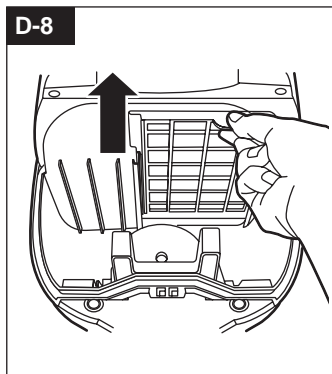
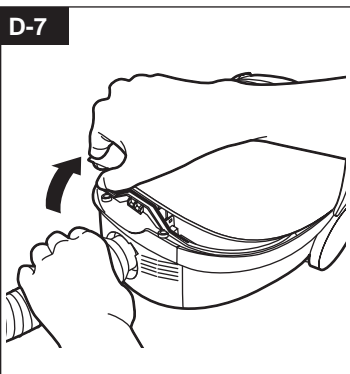
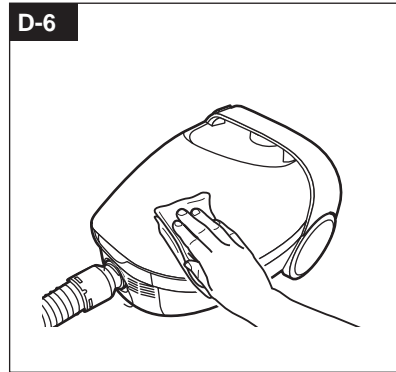
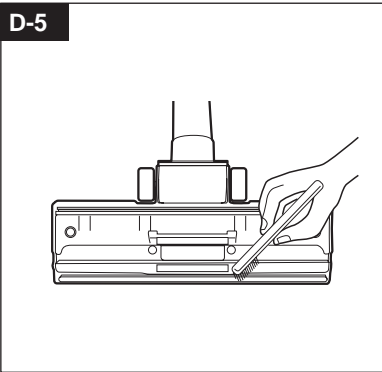
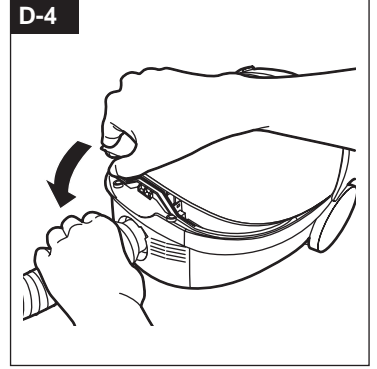
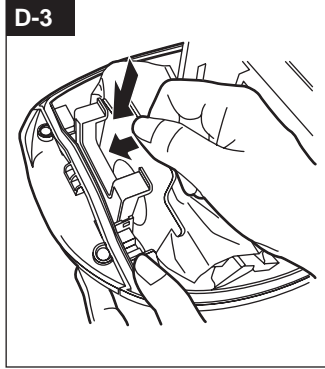
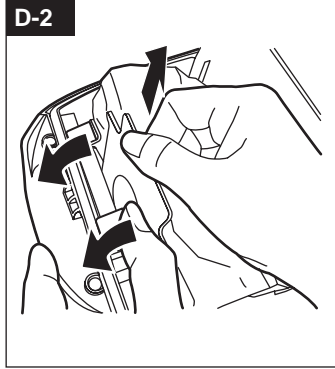
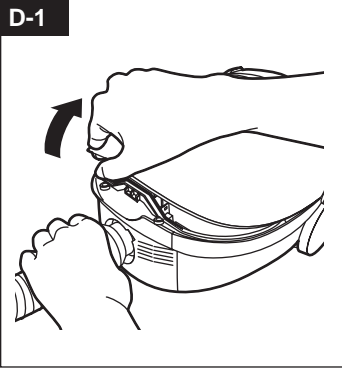

# WARRANTY

## Panasonic Vacuum Cleaner Limited Warranty (United States)

Panasonic Consumer Electronics Company (collectively referred to as "the warrantor" will repair this product with new or refurbished parts free of charge, in the U.S.A. or Puerto Rico for one (1) year from the date of original purchase in the event of a defect in materials or workmanship.

**This Limited Warranty Excludes both Labor and Parts for the following items which require normal replacement:** Disposable Dust Bag, Filters, Belts, Light Bulbs, Agitator Brushes and Batteries (if supplied).

Carry-in or mail-in service in the U.S.A. can be obtained during the warranty period by contacting a Panasonic Services Company (PASC) Factory Servicenter listed in the Servicenter Directory. Or call, toll-free, 1-800-211-PANA (7262) to locate a PASC Authorized Servicenter. Carry-in or mail-in service in Puerto Rico can be obtained during the warranty period by calling the local Panasonic Sales Company telephone number listed in the Servicenter Directory.

This warranty is extended only to the original purchaser. A purchase receipt or other proof of date of original purchase will be required before warranty performance is rendered.

This warranty only covers failures due to defects in materials and workmanship which occur during normal use and does not cover damages which occur in shipment, or failures which are caused by products not supplied by the warrantor, or failures which result from accident, misuse, abuse, neglect, mishandling, misapplication, faulty installation, improper operation or maintenance, alteration, modification, power line surge, improper voltage supply, lightning damage, commercial use such as hotel, office, restaurant or other business or rental use of the product, or service by anyone other than a PASC Authorized Servicenter, or damage that is attributable to acts of God.

### **LIMITS AND EXCLUSIONS:**

There are no express warranties except as listed above.

THE WARRANTOR SHALL NOT BE LIABLE FOR INCIDENTAL OR CONSEQUENTIAL DAMAGES RESULTING FROM THE USE OF THIS PRODUCT, OR ARISING OUT OF ANY BREACH OF THIS WARRANTY. ALL EXPRESS AND IMPLIED WARRANTIES, INCLUDING THE WARRANTIES OF MERCHANTABILITY AND FITNESS FOR A PARTICULAR PURPOSE, ARE LIMITED TO THE APPLICABLE WARRANTY PERIOD SET FORTH ABOVE.

Some states do not allow the exclusion or limitation of incidental or consequential damages, or limitations on how long an implied warranty lasts, so the above exclusions or limitations may not apply to you.

This warranty gives you specific legal rights and you may also have other rights which vary from state to state. If a problem with this product develops during or after the warranty period, you may contact your dealer or Servicenter. If the problem is not handled to your satisfaction, then write to the Consumer Affairs Department at the listed address on the back cover.

# Garantía

## Garantía de la aspiradora de Panasonic (United States)

*Panasonic Consumer Electronics Company o Panasonic Sales Company (colectivamente referido como garante) arreglará este producto gratis con piezas nuevas o restauradas en los Estados Unidos o Puerto Rico por un año de la fecha de compra original en caso de un defecto en las materiales o en el montaje del producto.*

***Esta garantía excluye ambos el labor y las piezas para las siguientes piezas que requieren el cambio normal:*** las bolsas para polvo, los filtros, las correas, las bombillas, los cepillos para agitador, y las pilas (si están incluidas).

*En los Estados Unidos puede llevar este producto para darle servicio durante el período de garantía a Panasonic Services Company (PASC) Factory Servicenter. Busque este nombre en el guía Servicenter. O llame gratis al 1-800-211-PANA (7262) para localizar un Centro PASC autorizado. En Puerto Rico, lleve o mande por correo este producto a la Panasonic Sales Company local durante el período de garantía. Busque el número de teléfono en el guía Servicenter.*

*Se ofrece únicamente la garantía al comprador original. Se necesitan el recibo de compra u otra prueba de la fecha de compra para obtener asistencia incluida en la garantía.*

*Esta garantía incluye únicamente los defectos en materiales o en el montaje que ocurre durante el uso normal y no incluye el daño causado por transporte o problemas que son causados por productos que no son Panasonic o problemas que resultan en los accidentes, el mal uso, el abuso, el descuido, el manejo malo, la aplicación mala, la instalación mala, la operación inapropiada, el cuidado malo, la alteración, la modificación de este producto, o el uso comercial como en hoteles, oficinas, restaurantes, o alquilar para uso, o arreglado por alguien que no está autorizado por Panasonic, o daños resultados por los actos de Dios.*

### ***Límites y exclusiones:***

*No hay garantías expresadas excepto las descritas arriba. El garante no será responsable de los daños incidentales o consiguientes resultados del uso de este producto o violación de esta garantía. Todas las garantías expresadas o implícitas incluso las garantías de comercio y del propósito particular están limitadas por el período de garantía descrito arriba.*

*Algunos estados no permiten el límite o la exclusión de daños incidentales o consiguientes ni límite del tiempo de la garantía por eso los límites o exclusiones descritos arriba no le son aplicables a usted.*

*Esta garantía le da ciertos derechos legales y es posible que usted tenga otros derechos que varían de estado a estado. Si un problema con esta problema ocurre durante o después del período de la garantía, puede informarse en su tienda o a su Centro de Servicio. Si el problema no se resuelve a su satisfacción, escriba al Consumer Affairs Department en la dirección incluida en la última página de este manual.*



Panasonic Canada Inc.  
5770 Ambler Drive, Mississauga, Ontario L4W 2T3

PANASONIC PRODUCT - LIMITED WARRANTY

## EXCHANGE PROGRAM

Panasonic Canada Inc. warrants this product to be free from defects in material and workmanship and agrees to replace the product for a period as stated below from the date of original purchase.

Vacuum Cleaner

One (1) year

### LIMITATIONS AND EXCLUSIONS

This warranty does not apply products purchased outside Canada or to any product which has been improperly installed, subjected to usage for which the product was not designed, misused or abused, damaged during shipping, or which has been altered or repaired in any way that affects the reliability or detracts from the performance, nor does it cover any product which is used commercially. Parts such as disposable dust bags, filters, belts, light bulbs and agitator brushes are not covered by this warranty.

Rechargeable batteries are warranted for ninety (90) days from date of original purchase. This warranty is extended to the original end user purchaser only. A purchase receipt or other proof of date of original purchase is required before warranty service is performed.

**THIS EXPRESS, LIMITED WARRANTY IS IN LIEU OF ALL OTHER WARRANTIES, EXPRESS OR IMPLIED, INCLUDING ANY IMPLIED WARRANTIES OF MERCHANTABILITY AND FITNESS FOR A PARTICULAR PURPOSE.**

**IN NO EVENT WILL PANASONIC CANADA INC. BE LIABLE FOR ANY SPECIAL, INDIRECT OR CONSEQUENTIAL DAMAGES.**

In certain instances, some jurisdictions do not allow the exclusion or limitation of incidental or consequential damages, or the exclusion of implied warranties, so the above limitations and exclusions may not be applicable.

### CONTACT INFORMATION

For product information and operation assistance, please contact:

Our Customer Care Centre: Telephone #: (905) 624-5505  
1-800#: 1-800-561-5505  
Fax #: (905) 238-2360  
Email link: "customer support" on [www.panasonic.ca](http://www.panasonic.ca)

For defective product exchange within the warranty period, please contact the original dealer or our Customer Care Centre.

Panasonic Canada Inc.  
5770 Ambler drive, Mississauga, Ontario L4W2T3

Certificat de garantie limitée Panasonic

## PROGRAMME D'ÉCHANGE

Panasonic Canada Inc. garantit cet appareil contre tout vice de fabrication et accepte de remplacer le produit pendant la période indiquée ci-dessous et commençant à partir de la date d'achat original.

Aspirateurs

Un (1) an

### LIMITATIONS ET EXCLUSIONS

Cette garantie n'est valide que pour les appareils achetés au Canada et ne couvre pas les dommages résultant d'une installation incorrecte, d'un usage abusif ou impropre ainsi que ceux découlant d'un accident en transit ou de manipulation. De plus, si l'appareil a été altéré ou transformé de façon à modifier l'usage pour lequel il a été conçu ou utilisé à des fins commerciales, cette garantie devient nulle et sans effet.

Les brosses, les courroies, les ampoules électriques, les filtres et les sacs à poussière ne sont pas couverts par cette garantie. Les piles rechargeables sont couvertes pour une période de quatre-vingt-dix (90) jours de la date d'achat original.

Cette garantie est octroyée à l'utilisateur original seulement. La facture ou autre preuve de la date d'achat original sera exigée pour toute réparation sous le couvert de cette garantie.

**CETTE GARANTIE LIMITÉE ET EXPRESSE REMPLACE TOUTE AUTRE GARANTIE, EXPRESSE OU IMPLICITE, INCLUANT LES GARANTIES IMPLICITES DU CARACTÈRE ADÉQUAT POUR LA COMMERCIALISATION ET UN USAGE PARTICULIER.**

**PANASONIC N'AURA D'OBLIGATION EN AUCUNE CIRCONSTANCE POUR TOUT DOMMAGE DIRECT, INDIRECT OU CONSÉCUTIF.**

Certaines juridictions ne reconnaissent pas les exclusions ou limitations de dommages indirects ou consécutifs, ou les exclusions de garanties implicites. Dans de tels cas, les limitations stipulées ci-dessus peuvent ne pas être applicables.

### DEMANDE DE RENSEIGNEMENTS

Pour des renseignements ou de l'aide sur le fonctionnement de l'appareil, veuillez contacter notre service à la clientèle au :

N° de téléphone: (905) 624-5505  
Ligne sans frais: 1-800-561-5505  
N° de télécopieur : (905) 238-2360  
Lien courriel : «Contactez-nous» à [www.panasonic.ca](http://www.panasonic.ca)

Pour l'échange de produits défectueux durant la période de garantie, veuillez contacter votre détaillant ou notre service à la clientèle.

**PANASONIC CORPORATION  
OF NORTH AMERICA**

One Panasonic Way Secaucus,  
New Jersey 07094  
World Wide Web Address  
<http://www.panasonic.com>

**PANASONIC SALES COMPANY,  
DIVISION OF PANASONIC PUERTO  
RICO, INC.**

Ave. 65 de Infanteria.Km.9.5 San Gabriel  
Industrial Park Carolina,Puerto Rico 00985

**PANASONIC CANADA INC.**

5770 Ambler Drive Mississauga, Ontario  
L4W 2T3

V01Z5400U  
C0808-0

Printed in P.R.C.  
Imprimé à R.P.C.