

This Owner's Manual is provided and hosted by [Appliance Factory Parts](#).



PANASONIC MC-GG213 Owner's Manual

[Shop genuine replacement parts for PANASONIC
MC-GG213](#)



[Find Your PANASONIC Vacuum Cleaner Parts - Select From 605 Models](#)

----- Manual continues below -----

Panasonic®

VACUUM CLEANER (COMMERCIAL)

Aspirateur

Aspiradora

MC-GG213

Operating Instructions

Manuel d'utilisation

Instrucciones de operación

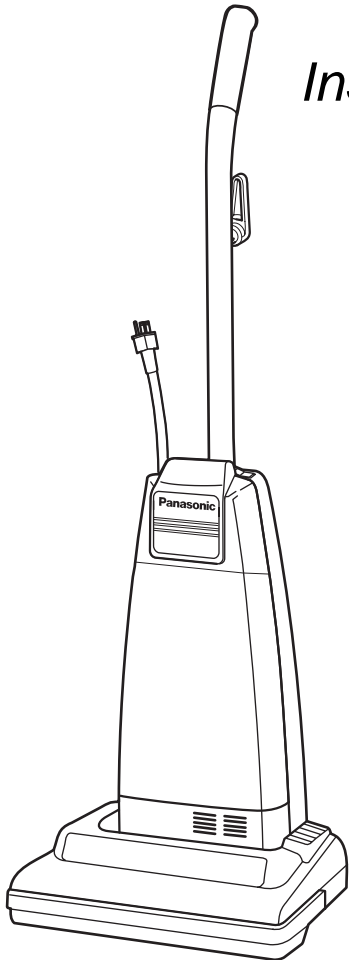

**Before operating your vacuum cleaner,
please read these instructions completely.**

Avant d'utiliser l'appareil, il est recommandé
de lire attentivement ce manuel.

*Antes de usar su aspiradora, lea
completamente estas instrucciones por favor.*

TABLE OF CONTENTS

CONSUMER INFORMATION	4
IMPORTANT SAFETY INSTRUCTIONS.....	7
GROUNDING INSTRUCTIONS	10
PARTS IDENTIFICATION.....	12
FEATURE CHART	13
ASSEMBLY.....	14
Attaching Handle.....	14
Power Cord	14
TO OPERATE VACUUM CLEANER	16
Power Cord	16
ON-OFF Switch.....	16
Handle Adjustments.....	18
FEATURES	20
Automatic Self Adjusting Nozzle	20
Edge Cleaning	20
Motor Protector	20
ROUTINE CARE OF VACUUM CLEANER	22
Replacing Secondary HEPA Filter	22
Changing Dust Bag.....	22, 24
Removing and Installing Lower Plate	26
Replacing Belt	28
Cleaning Agitator.....	30
Replacing Agitator.....	30
Agitator Assembly.....	32
Removing Clogs	34
BEFORE REQUESTING SERVICE	36
WARRANTY	39, 40
NOTES.....	43
WHAT TO DO WHEN SERVICE IS NEEDED.....	44

CONSUMER INFORMATION

Please read **IMPORTANT SAFETY INSTRUCTIONS** on page 7 before use. Read and understand all instructions.

TO OUR VALUED CUSTOMER

We are very pleased to welcome you to the Panasonic family of products. Thank you for purchasing this product. Our intent is that you become one of our many satisfied customers.

Proper assembly and safe use of your vacuum cleaner are your responsibilities. Your vacuum cleaner is intended only for commercial use. The vacuum cleaner should be stored in a dry, indoor area. Read the Operating Instructions carefully for important use and safety information.

Special care is required when vacuuming certain types of carpet or floor covering. Always check the carpet or floor covering manufacturer's recommended cleaning instructions before vacuuming.

PLEASE PAY CLOSE ATTENTION TO ALL WARNING AND CAUTION STATEMENTS.

WARNING

WARNING statements are designed to alert you to the possibility of personal injury, loss of human life, and/or damage to the vacuum cleaner and/or personal property if the instructions given are not followed.

CAUTION

CAUTION statements are designed to alert you to the possibility of damage to the vacuum cleaner and/or personal property if the instructions given are not followed.

WARNING

TO AVOID ELECTRICAL SHOCK

Never vacuum damp or wet surfaces or liquids.
DO NOT store vacuum cleaner outdoors.
Replace worn or frayed power cord immediately.
Unplug from outlet when not in use and before servicing.

TO AVOID ACCIDENTS

Except for hand-held vacuum cleaners, keep vacuum cleaner on floor - not chairs, tables, steps, stairs, etc.
Store vacuum cleaner promptly after each use to prevent accidents such as tripping over power cord or vacuum cleaner.
Use vacuum cleaner and accessories only in a manner intended by the manufacturer.
The use of an extension cord is not recommended.

IMPORTANT SAFETY INSTRUCTIONS

When using your vacuum cleaner, basic precautions should always be followed, including the following:

Read all instructions in this manual before assembling or using your vacuum cleaner.

WARNING To reduce the risk of fire, electrical shock, injury:

1. **Read** all instructions in this manual before assembling or using your vacuum cleaner.
2. **Use** your vacuum cleaner only as described in this manual. Use only with Panasonic recommended attachments.
3. **Disconnect** electrical supply before servicing or cleaning out the brush area. Failure to do so could result in the brush unexpectedly starting, causing personal injury from moving parts.
4. **Do not** leave vacuum cleaner when plugged in. Unplug from outlet when not in use and before servicing.
5. **To reduce** the risk of electrical shock - Do not use outdoors or on wet surfaces.
6. **Do not** allow to be used as a toy. Close attention is necessary when used by or near children.
7. **Do not** use with a damaged cord or plug. If vacuum cleaner is not working as it should, has been dropped, damaged, left outdoors, or dropped in water, return it to a Panasonic Service Center.
8. **Do not** pull or carry by cord, use cord as a handle, close a door on cord, or pull cord around sharp edges or corners. Do not run vacuum cleaner over cord. Keep cord away from heated surfaces.
9. **Do not** unplug by pulling on cord. To unplug, grasp the plug, not the cord.
10. **Do not** handle plug or vacuum cleaner with wet hands.
11. **Do not** put any objects into openings.
12. **Do not** use with any opening blocked; keep free of dust, lint, hair, and anything that may reduce air flow.
13. **Keep** hair, loose clothing, fingers, and all parts of body away from openings and moving parts.
14. **Turn off** all controls before unplugging.
15. **Use** extra care when cleaning on stairs. Do not put on chairs, tables, etc. Keep on floor.
16. **Do not** use vacuum cleaner to pick up flammable or combustible liquids (gasoline, cleaning fluid, perfumes, etc.), or use in areas where they may be present. The fumes from these substances can create a fire hazard or explosion.
17. **Do not** pick up anything that is burning or smoking, such as cigarettes, matches, or hot ashes.
18. **Do not** use vacuum cleaner without dust bag and/or filters in place.
19. **You are** responsible for making sure that your vacuum cleaner is not used by anyone unable to operate it properly.
20. **Connect** to a properly grounded outlet only. See Grounding Instructions.

SAVE THESE INSTRUCTIONS

THIS VACUUM CLEANER IS INTENDED FOR COMMERCIAL USE

NOTE: Before you plug in your Panasonic vacuum cleaner, make sure that the voltage indicated on the rating plate located at the back of the vacuum cleaner is the same as your local electrical supply.

GROUNDING INSTRUCTIONS

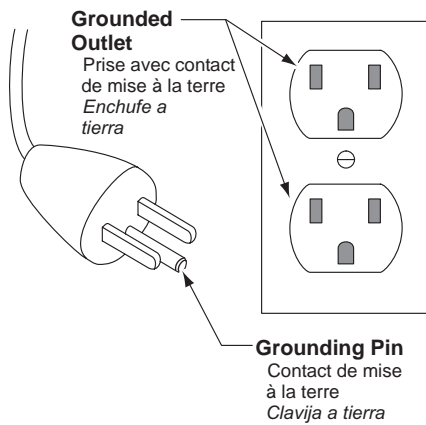

Figure A

Figure A
Figura A

This vacuum cleaner must be grounded. If it should malfunction or breakdown, grounding provides a path of least resistance for electric current to reduce the risk of electric shock. This vacuum cleaner is equipped with a cord having an equipment-grounding conductor and grounding plug. The plug must be plugged into an appropriate outlet that is properly installed and grounded in accordance with all local codes and ordinances.

⚠ DANGER

Improper connection of the equipment-grounding conductor can result in a risk of electric shock. Check with a qualified electrician or service person if you are in doubt as to whether the outlet is properly grounded. Do not modify the plug provided with the vacuum cleaner – if it will not fit the outlet, have a proper outlet installed by a qualified electrician.

This vacuum cleaner is for use on a nominal 120-volt circuit, and has a grounding plug that looks like the plug illustrated in **Figure A**. Make sure that this vacuum cleaner is connected to an outlet having the same configuration as the plug.

No adapter should be used with this vacuum cleaner.

Note: Before you plug in your commercial vacuum cleaner, make sure that the voltage indicated on the rating plate located at the back of the vacuum cleaner is the same as your local supply.

PARTS IDENTIFICATION

Nomenclature

Identificación de piezas

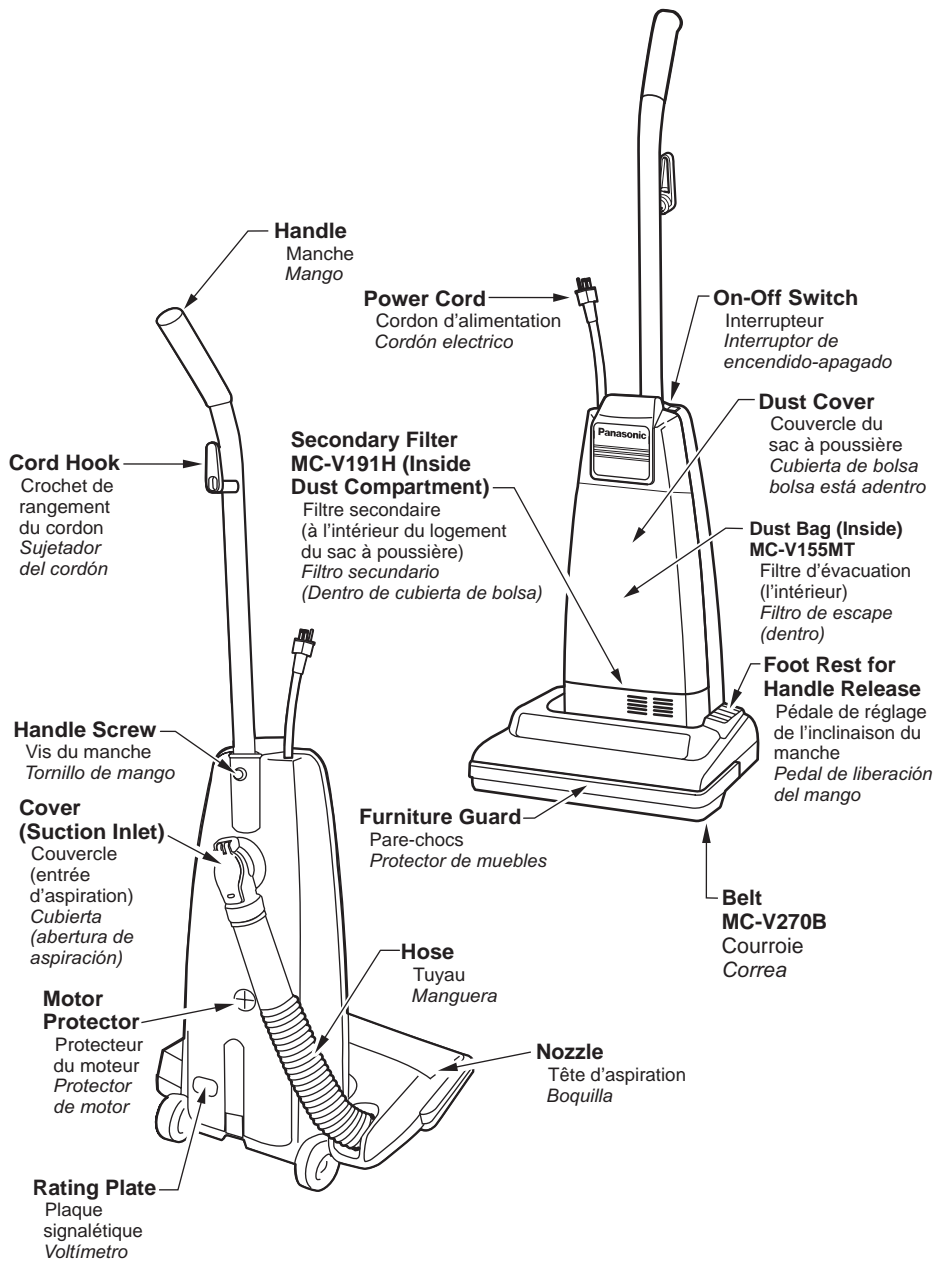

FEATURE CHART

Power	Thermal Protector	Edge Cleaning	Height Adjustment
120V AC (60 Hz)	Yes	Yes	Auto

Tableau des caractéristiques

Alimentation	Protecteur thermique	Nettoyage latéral	Réglage de la hauteur
120 V c.a. (60 Hz)	Oui	Oui	Auto

Diagrama de características

<i>Voltaje</i>	<i>Protector termal</i>	<i>Edge Cleaning</i>	<i>Height Adjustment</i>
120 V c.a. (60 Hz)	<i>Si</i>	<i>Si</i>	<i>Auto</i>

ASSEMBLY

Attaching Handle

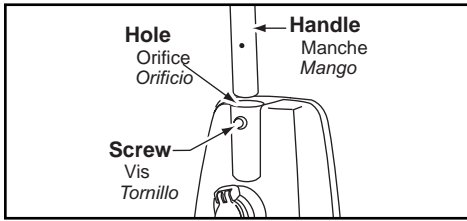

- **DO NOT** plug in until assembly is complete.
- Remove handle screw.
- Insert handle with cord hooks to the back of the vacuum cleaner.

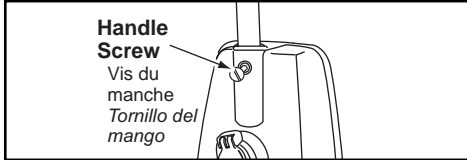

- Insert screw.
- Tighten screw.

POWER CORD

⚠ WARNING

Electrical Shock or Personal Injury Hazard

The cord set used with this product must be **GROUND**ED for safe operation. Any extension cord set used with this vacuum cleaner **MUST** be grounded (3-wire with two flat blades and one round ground prong). Only use a UL Listed Cord Set with this product. The Extension Cord Set **MUST** be Type S**J**T, sized 18 AWG minimum, and rated 120V minimum.

- Make sure the extension cord set is in good condition.
- The extension cord set must be heavy enough to carry the current from the vacuum cleaner.
- An undersized extension cord set will cause a drop in line voltage resulting in a loss of power and overheating of the vacuum cleaner.

TO OPERATE VACUUM CLEANER

Power Cord

- Only use outlets near the floor.

ON-OFF Switch

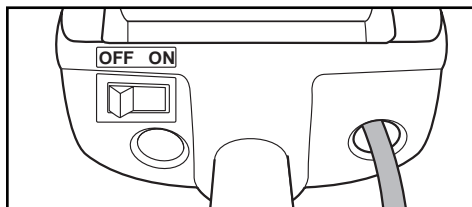

- Ensure ON-OFF switch is OFF.
- Plug the power cord into 120V outlet.
- ON position turns vacuum cleaner on.
- OFF position turns vacuum cleaner off.



CAUTION

Moving parts! To reduce the risk of personal injury, DO NOT touch the agitator when vacuum cleaner is on. Contacting the agitator while it is rotating can cut, bruise or cause other injuries. Always unplug from electrical outlet before servicing. Use caution when operating near children.

Handle Adjustments

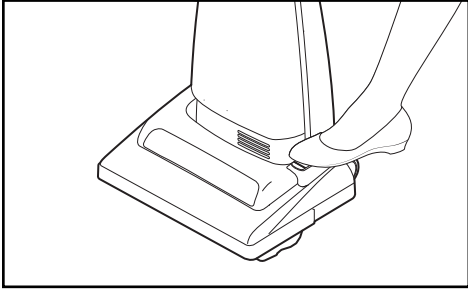

- Step on foot rest to change handle position.

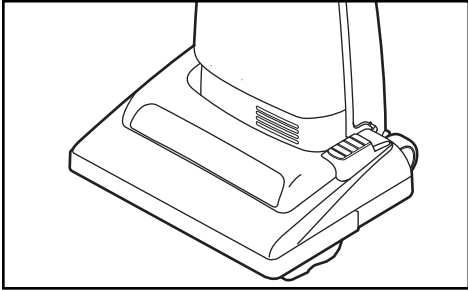

- Move vacuum cleaner to upright position for storage and tool use.

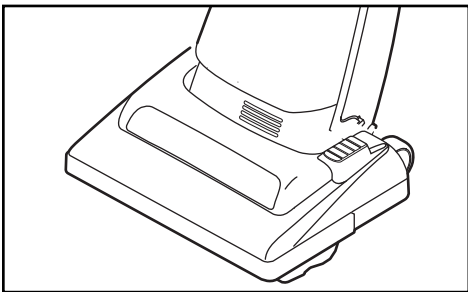

- Move vacuum cleaner to middle position for normal use.

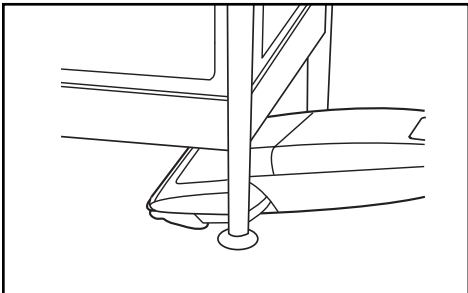

- Use low position for cleaning under furniture.

FEATURES

Automatic Self Adjusting Nozzle

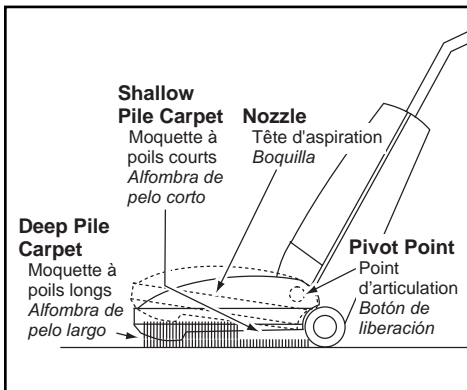

- The nozzle of your Panasonic upright vacuum cleaner automatically adjusts to any carpet pile height.
- Feature allows nozzle to float evenly over carpet pile surfaces.
- No manual adjustments required.

Edge Cleaning

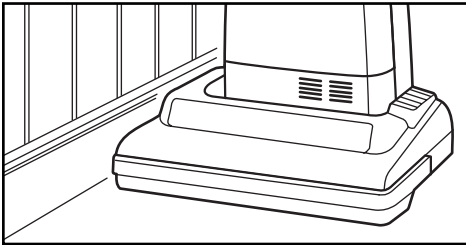

- The edge cleaning feature of your new vacuum cleaner enables improved cleaning of carpets near walls and furniture.

Motor Protector

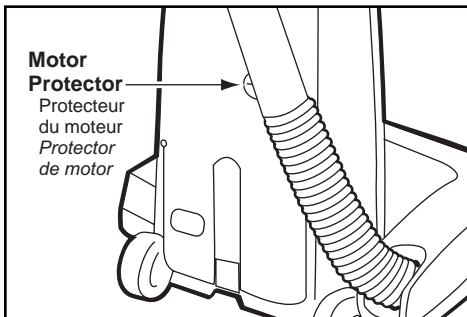

- Automatically opens to provide cooling air to the motor when a clog occurs or when dust bag needs changing.
- Motor protector may open when using tools.
- If motor protector opens, the vacuum cleaner will make a slightly different sound.

Note: Do not block motor protector.

ROUTINE CARE OF VACUUM CLEANER

Performing the following tasks will keep your new Panasonic vacuum cleaner operating at peak performance levels and will ensure these high levels for years to come. Check the **BEFORE REQUESTING SERVICE** section in this manual for recommendations on performing some of these tasks to help solve various problems that may occur.

Replacing Secondary HEPA Filter

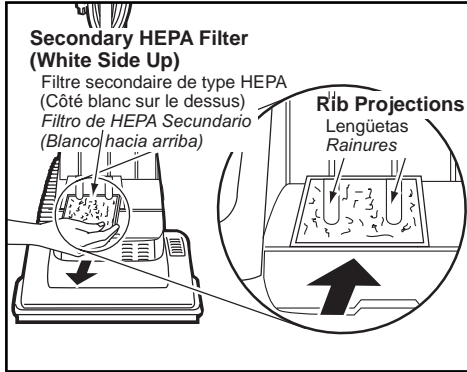

- Secondary HEPA filter protects the motor.
- Check filter when installing a new dust bag.
- If dirty, pull filter from bottom of dust compartment and replace.
- Place new filter, white side up, in dust compartment, **DO NOT CLEAN WITH WATER***.
- Ensure filter is fully inserted under plastic rib projections.

*Filter cannot be cleaned and should be replaced at least once each year.

Changing Dust Bag

Always operate vacuum cleaner with genuine Panasonic type dust bags installed. Panasonic dust bags may be purchased through any authorized Panasonic dealer or ordered from service company.

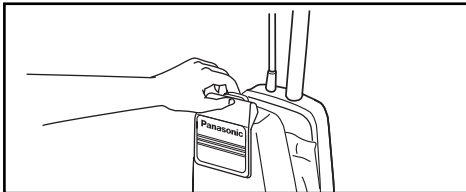

- Pull outward to remove dust cover.

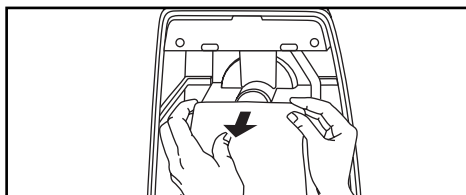

Changing Dust Bag

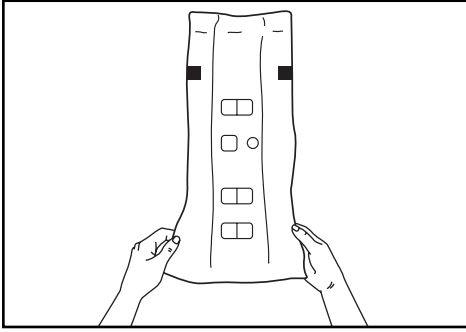

- Spread out new dust bag, taking care not to tear bag.

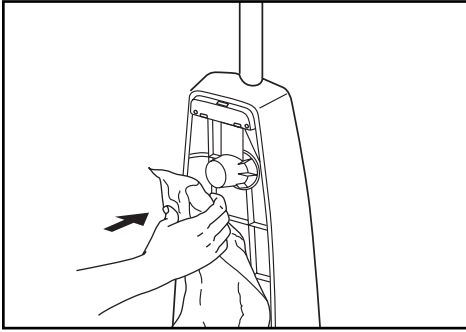

- Attach new dust bag onto bag holder by holding cardboard portion and pushing back.



- Reinsert tab on end of dust cover into groove on dust compartment.

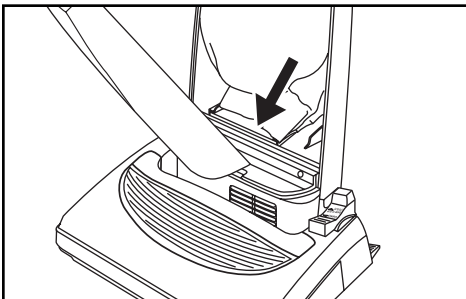

- Press dust cover into place without pinching dust bag.

! WARNING Electrical Shock or Personal Injury Hazard

Disconnect the electrical supply before servicing or cleaning the vacuum cleaner. Failure to do so could result in electrical shock or personal injury from vacuum cleaner suddenly starting.

Removing and Installing Lower Plate

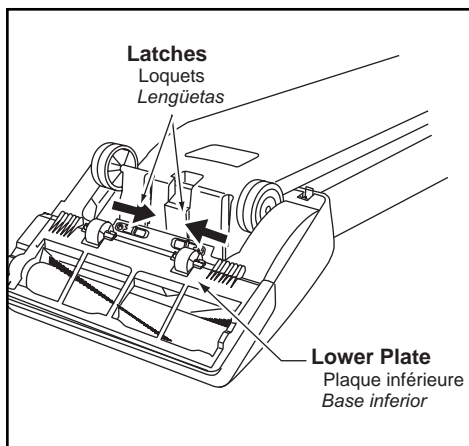

- **Before servicing any parts, disconnect vacuum cleaner from electrical outlet.**
- **Place paper under nozzle anytime lower plate is removed to protect floor.**
- **Place handle in down position and turn vacuum cleaner over to expose lower plate.**
- **Release lower plate by pressing two (2) latches inward.**
- **Remove lower plate and remove any residue that may exist in belt area.**

- **Reinstall lower plate by hooking front end of lower plate into slots on front of nozzle housing.**
- **Make sure all wires are routed properly and not pinched.**
- **Press lower plate into place then replace three (3) screws.**

Replacing Belt

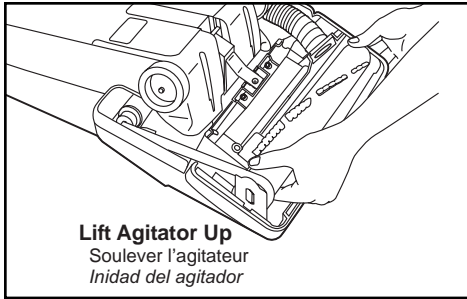

- Remove lower plate.
- Remove agitator by carefully lifting out.

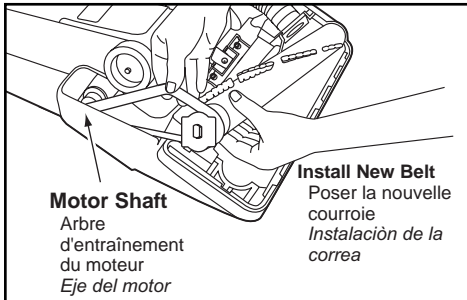

- Remove worn or broken belt.
- Loop new belt (**Panasonic Type UB8 only**) around motor shaft and belt pulley; see illustration for correct belt routing.
- Reinstall agitator back into nozzle housing grooves.

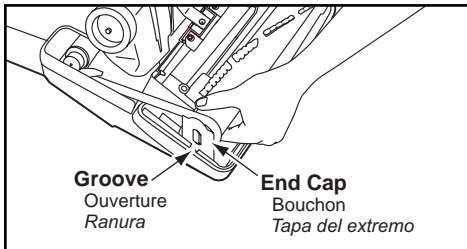

- After reinstalling the agitator, turn it by hand to make sure that belt is not twisted or pinched and that all rotating parts turn freely.
- Reinstall lower plate.

Cleaning Agitator

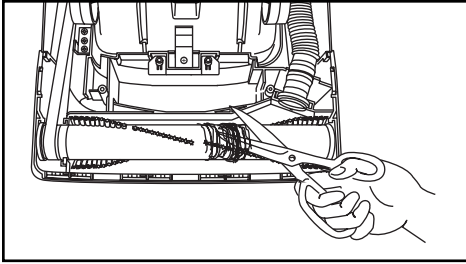

- Clean agitator after every five uses and every time the belt is replaced.
- Remove lower plate.
- Cut off any carpet pile and lint entangled around agitator with a pair of scissors.
- Remove agitator.
- Remove any string or debris located on the end caps.
- Reinstall agitator and lower plate.

Replacing Agitator

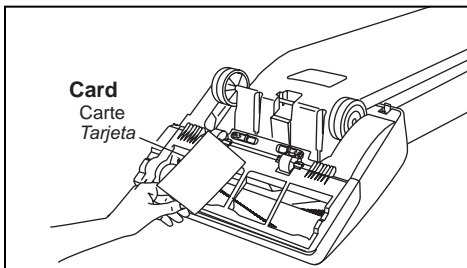

- When the bristles on the agitator are worn so that they do not touch a card held across the lower plate, the agitator should be replaced.
- Remove lower plate and agitator.
- Clean debris from end caps.
- Position belt over belt pulley on the new agitator.
- Reinstall agitator and lower plate.

Agitator Assembly

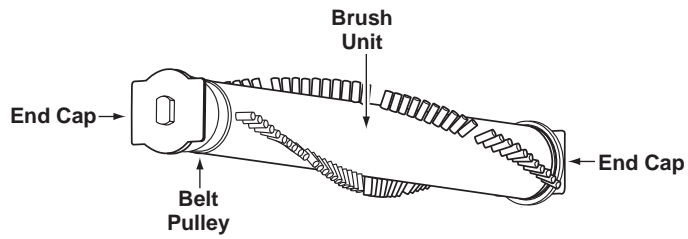

Cleaning Exterior

- Unplug cord from wall outlet.
- Clean exterior using a clean, soft cloth that has been dipped in a solution of mild liquid detergent and water and wrung dry.
- DO NOT drip water on vacuum cleaner, wipe dry after cleaning.
- DO NOT clean tools in dishwasher or clothes washer.
- Wash tools in warm, soapy water, rinse and air dry.
- DO NOT use tools if they are wet.

Removing Clogs

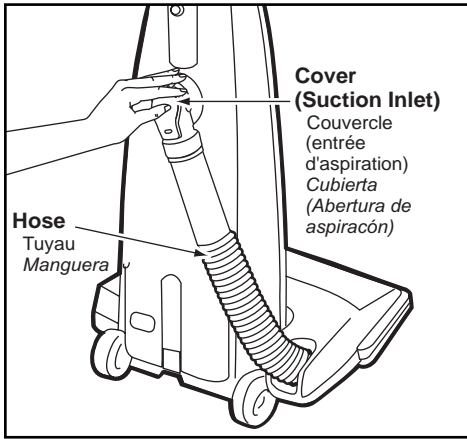

The hose located on the back of the vacuum cleaner carries the dirt from the nozzle up to the dust bag. If the hose should become clogged:

- **Unplug vacuum cleaner.**
- **Pull open suction inlet cover and check for clogging.**
- **Remove lower plate.**
- **Remove hose from nozzle by lifting straight up.**
- **Inspect hose end and clear any obstructions.**
- **Reinstall hose and lower plate.**

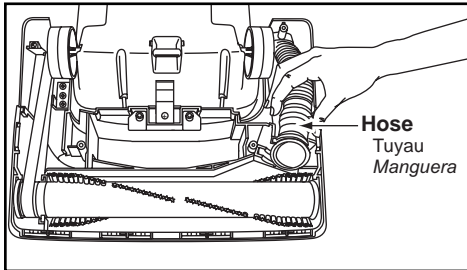

BEFORE REQUESTING SERVICE

 WARNING Electrical Shock or Personal Injury Hazard

Disconnect the electrical supply before servicing or cleaning the vacuum cleaner. Failure to do so could result in electrical shock or personal injury from vacuum cleaner suddenly starting.

Review this chart to find do-it-yourself solutions for minor performance problems. Any service needed, other than those described in these Operating Instructions, should be performed by an authorized service representative.

PROBLEM	POSSIBLE CAUSE	POSSIBLE SOLUTION
Vacuum cleaner will not run.	<ol style="list-style-type: none"> 1. Unplugged at wall outlet. 2. ON-OFF switch not turned on. 3. Tripped circuit breaker/blown fuse at household service panel. 	<ol style="list-style-type: none"> 1. Plug in firmly. Push ON-OFF switch to On. 2. Push ON-OFF switch to ON. 3. Reset circuit breaker or replace fuse.
Poor job of dirt pickup.	<ol style="list-style-type: none"> 1. Full or clogged dust bag. 2. Broken belt. 3. Clogged hose or nozzle. 4. Hose not inserted fully. 5. Worn agitator. 6. Hole in hose. 7. Dust cover improperly installed. 	<ol style="list-style-type: none"> 1. Change bag. 2. Replace belt. 3. Clean hose or nozzle area. 4. Insert hose. 5. Replace agitator. 6. Replace hose. 7. Properly install dust cover.
Dust escapes the paper bag.	<ol style="list-style-type: none"> 1. Bag improperly installed. 2. Bag torn. 	<ol style="list-style-type: none"> 1. Properly install bag. 2. Replace bag.

WARRANTY, Garantie, Garantía

Panasonic Commercial Vacuum Cleaner Limited Warranty

Panasonic Consumer Electronics Company (collectively referred to as "the warrantor") will repair this product with new or refurbished parts free of charge, in the U.S.A. or Puerto Rico for one (1) year from the date of original purchase in the event of a defect in materials or workmanship.

This Limited Warranty Excludes both Labor and Parts for the following items which require normal replacement: Disposable Dust Bag, Filters, Belts, Light Bulbs, Agitator Brushes and Batteries (if supplied).

Carry-in or mail-in service in the U.S.A. can be obtained during the warranty period by contacting a Panasonic Services Company (PASC) Factory Servicenter listed in the Servicenter Directory. Or call, toll free, 1-800-211-PANA (7262) to locate a PASC Authorized Servicenter. Carry-in or mail-in service in Puerto Rico can be obtained during the warranty period by calling the local Panasonic Sales Company telephone number listed in the Servicenter Directory.

This warranty is extended only to the original purchaser. A purchase receipt or other proof of date of original purchase will be required before warranty performance is rendered.

This warranty only covers failures due to defects in materials and workmanship which occur during normal use and does not cover damages which occur in shipment, or failures which are caused by products not supplied by the warrantor, or failures which result from accident, misuse, abuse, neglect, bug infestation, mishandling, misapplication, faulty installation, improper operation or maintenance, alteration, modification, power line surge, improper voltage supply, lightning damage, or service by anyone other than a PASC Authorized Servicenter, or damage that is attributable to acts of God.

LIMITS AND EXCLUSIONS:

There are no express warranties except as listed above.

THE WARRANTOR SHALL NOT BE LIABLE FOR INCIDENTAL OR CONSEQUENTIAL DAMAGES RESULTING FROM THE USE OF THIS PRODUCT, OR ARISING OUT OF ANY BREACH OF THIS WARRANTY. ALL EXPRESS AND IMPLIED WARRANTIES, INCLUDING THE WARRANTIES OF MERCHANTABILITY AND FITNESS FOR A PARTICULAR PURPOSE, ARE LIMITED TO THE APPLICABLE WARRANTY PERIOD SET FORTH ABOVE.

Some states do not allow the exclusion or limitation of incidental or consequential damages, or limitations on how long an implied warranty lasts, so the above exclusions or limitations may not apply to you.

This warranty gives you specific legal rights and you may also have other rights which vary from state to state. If a problem with this product develops during or after the warranty period, you may contact your dealer or Servicenter. If the problem is not handled to your satisfaction, then write to the Consumer Affairs Department at the listed address on the back cover.

PANASONIC PRODUCT - LIMITED WARRANTY

Panasonic Canada Inc. warrants this product to be free from defects in material and workmanship under normal use and for a period as stated below from the date of original purchase agrees to, at its option either (a) repair your product with new or refurbished parts, (b) replace it with a new or a refurbished equivalent value product, or (c) refund your purchase price. The decision to repair, replace or refund will be made by Panasonic Canada Inc.

Commercial Vacuum Cleaner Ninety (90) days parts and labour

This warranty is given only to the original purchaser, or the person for whom it was purchased as a gift, of a Panasonic brand product mentioned above sold by an authorized Panasonic dealer in Canada and purchased and used in Canada, which product was not sold "as is", and which product was delivered to you in new condition in the original packaging.

IN ORDER TO BE ELIGIBLE TO RECEIVE WARRANTY SERVICE HEREUNDER, A PURCHASE RECEIPT OR OTHER PROOF OF DATE OF ORIGINAL PURCHASE, SHOWING AMOUNT PAID AND PLACE OF PURCHASE IS REQUIRED

LIMITATIONS AND EXCLUSIONS

This warranty ONLY COVERS failures due to defects in materials or workmanship, and DOES NOT COVER normal wear and tear or cosmetic damage. The warranty ALSO DOES NOT COVER damages which occurred in shipment, or failures which are caused by products not supplied by Panasonic Canada Inc., or failures which result from accidents, misuse, abuse, neglect, mishandling, misapplication, alteration, faulty installation, set-up adjustments, misadjustment of consumer controls, improper maintenance, power line surge, lightning damage, modification, introduction of sand, humidity or liquids, or service by anyone other than a Authorized Servicer, or damage that is attributable to acts of God.

Parts such as disposable dust bags, filters, belts, light bulbs and agitator brushes are not covered by this warranty.

THIS EXPRESS, LIMITED WARRANTY IS IN LIEU OF ALL OTHER WARRANTIES, EXPRESS OR IMPLIED, INCLUDING ANY IMPLIED WARRANTIES OF MERCHANTABILITY AND FITNESS FOR A PARTICULAR PURPOSE. IN NO EVENT WILL PANASONIC CANADA INC. BE LIABLE FOR ANY SPECIAL, INDIRECT OR CONSEQUENTIAL DAMAGES RESULTING FROM THE USE OF THIS PRODUCT OR ARISING OUT OF ANY BREACH OF ANY EXPRESS OR IMPLIED WARRANTY. (As examples, this warranty excludes damages for lost time, travel to and from the Authorized Servicer, loss of or damage to media or images, data or other memory or recorded content. This list of items is not exhaustive, but for illustration only.)

In certain instances, some jurisdictions do not allow the exclusion or limitation of incidental or consequential damages, or the exclusion of implied warranties, so the above limitations and exclusions may not be applicable. This warranty gives you specific legal rights and you may have other rights which vary depending on your province or territory.

WARRANTY SERVICE

For product operation and information assistance, please contact:

PRODUCT OPERATION ASSISTANCE

Customer Care Centre:

Telephone #: 1-800-561-5505

Fax #: (905) 238-2360

Email link: "Support → contact us → email" on www.panasonic.ca

PRODUCT REPAIRS

Please locate your nearest Authorized Servicentre.

Link: "Support → Panasonic Servicentre® locator" on www.panasonic.ca

IF YOU SHIP THE PRODUCT TO A SERVICENTRE

Carefully pack and send prepaid, adequately insured and preferably in the original carton.
Include details of the defect claimed, and proof of date of original purchase.

WHAT TO DO WHEN SERVICE IS NEEDED

If your Panasonic Vacuum Cleaner needs service, look in the yellow pages of the telephone book under HOME APPLIANCE SERVICE for your nearest Panasonic Services Company ("PASC") Factory Servicenter, or PASC authorized Servicenter, or call, 1-800-211-PANA (7262) toll free to find a convenient servicenter. **DO NOT send the product to the Executive or Regional Sales offices. They are NOT equipped to make repairs.**

If you ship the product

Carefully pack and send it prepaid, adequately insured and preferably in the original carton. Attach a postage-paid letter to the outside of the carton, which contains a description of your complaint. **DO NOT send the product to the Executive or Regional Sales Offices. They are NOT equipped to make repairs.**

PANASONIC CONSUMER ELECTRONICS COMPANY
DIVISION OF MATSUSHITA ELECTRIC CORPORATION OF AMERICA

One Panasonic Way
Secaucus, New Jersey 07094
World Wide Web Address
<http://www.panasonic.com>

What to do when service is needed Service après-vente (Canada)

WARRANTY SERVICE

For product operation and information assistance, please contact your Dealer or our Customer Care Centre at:
Telephone #: 1-800-561-5505 Fax #: (905) 238-2360 Web: www.panasonic.ca

For product repairs, please locate your nearest Authorized Servicecentre.

Link: "Support → Panasonic Servicecentre locator" on www.panasonic.ca

RÉPARATION SOUS GARANTIE

Pour de l'aide sur le fonctionnement de l'appareil ou pour toute demande d'information, veuillez contacter votre détaillant ou notre service à la clientèle au :

N° de téléphone : 1-800-561-5505 N° de télécopieur : (905) 238-2360 Site Internet : www.panasonic.ca

Pour la réparation des appareils, veuillez localiser le centre de service agréé le plus près de votre domicile.

Lien: "Support à la clientèle → Centres de service" sur le site www.panasonic.ca.

Quando necesita servicio

Si su aspiradora Panasonic necesita servicio, busque el Centro de Servicio Panasonic o un Centro de Servicio PASC autorizado más cercano bajo "Servicio de Electrodomésticos" en las páginas amarillas de la guía de teléfonos o llame gratis al 1-800-211-PANA (7262) para encontrar un centro de servicio conveniente. **No mande el producto a las Executive o Regional Sales Offices. No están equipadas para arreglar estos productos.**

Si manda el producto

Empaquete con cuidado en el cartón original si es posible y mándelo prepagado y con seguro suficiente. Ponga una carta con sellos en la que describe su problema con el producto en el exterior del cartón. **No mande el producto a las Executive o Regional Sales Offices. No están equipadas para arreglar estos productos.**

PANAMEX COMPANY
DIVISION OF PANASONIC CORPORATION OF NORTH AMERICA

One Panasonic Way
Secaucus, New Jersey 07094
World Wide Web Address
<http://www.panasonic.com>

ACØ1ZDKPØØØØ
CØ1ZDKPØØØØØØ

Printed in Mexico
Imprimé au Mexique
Impreso en Mexico