

This Owner's Manual is provided and hosted by [Appliance Factory Parts](#).



# PANASONIC MC-V5210 Owner's Manual

[Shop genuine replacement parts for PANASONIC  
MC-V5210](#)



[Find Your PANASONIC Vacuum Cleaner Parts - Select From 605 Models](#)

----- Manual continues below -----

# Panasonic®

## Operating Instructions Manuel d'utilisation *Instrucciones de operación*

**COMMERCIAL VACUUM CLEANER**  
Aspirateur commercial  
*Aspiradora Comercial*

# MC-V5210

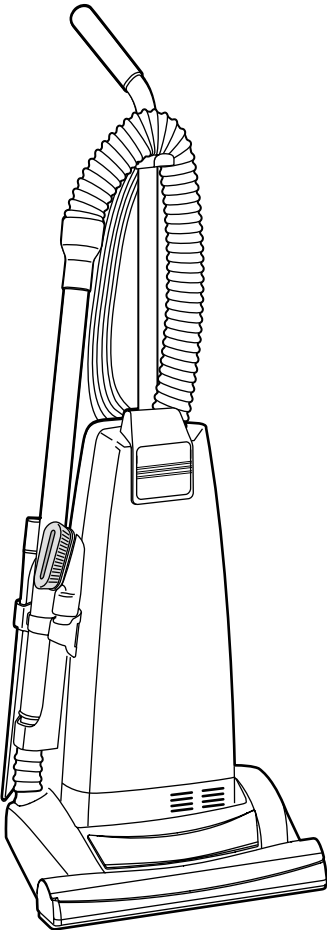

**Before operating your vacuum cleaner,  
please read these instructions completely.**

Avant d'utiliser l'appareil, il est recommandé  
de lire attentivement ce manuel.

*Antes de usar su aspiradora, lea  
completamente estas instrucciones por favor.*

# CONSUMER INFORMATION

Please read **IMPORTANT SAFETY INSTRUCTIONS** on page 5 before use. Read and understand all instructions.

## TO OUR VALUED CUSTOMER

We are very pleased to welcome you to the Panasonic family of products. Thank you for purchasing this product. Our intent is that you become one of our many satisfied customers.

**Proper assembly and safe use of your vacuum cleaner are your responsibilities. Your vacuum cleaner is intended for commercial use. The cleaner should be stored in a dry, indoor area. Read the Operating Instructions carefully for important use and safety information.**

**Special care is required when vacuuming certain types of carpet or floor covering. Always check the carpet or floor covering manufacturer's recommended cleaning instructions before vacuuming.**

## PLEASE PAY CLOSE ATTENTION TO ALL WARNING AND CAUTION STATEMENTS.



**WARNING** statements are designed to alert you to the possibility of personal injury, loss of human life, and/or damage to the vacuum cleaner and/or personal property if the instructions given are not followed.



**CAUTION** statements are designed to alert you to the possibility of damage to the vacuum cleaner and/or personal property if the instructions given are not followed.



### TO AVOID ELECTRICAL SHOCK

Never vacuum damp or wet surfaces or liquids.  
DO NOT store machine outdoors.  
Replace worn or frayed power cord immediately.  
Unplug from outlet when not in use and before servicing.

### TO AVOID ACCIDENTS

Except for hand-held cleaners, keep machine on floor - not chairs, tables, steps, stairs, etc.  
Store machine promptly after each use to prevent accidents such as tripping over power cord or machine.  
Use machine and accessories only in a manner intended by the manufacturer.  
The use of an extension cord is not recommended.

# IMPORTANT SAFETY INSTRUCTIONS

When using your vacuum cleaner, basic precautions should always be followed, including the following:

Read all instructions in this manual before assembling or using your vacuum cleaner.

## **WARNING** To reduce the risk of fire, electrical shock, injury:

1. **Read** all instructions in this manual before assembling or using your vacuum cleaner.
2. **Use** your cleaner only as described in this manual. Use only with Panasonic recommended attachments.
3. **Disconnect** electrical supply before servicing or cleaning out the brush area. Failure to do so could result in electrical shock or the brush suddenly starting.
4. **Do not** leave cleaner when plugged in. Unplug from outlet when not in use and before servicing.
5. **To** reduce the risk of electrical shock - Do not use outdoors or on wet surfaces.
6. **Do not** allow to be used as a toy. Close attention is necessary when used by or near children.
7. **Do not** use with a damaged cord or plug. If cleaner is not working as it should, has been dropped, damaged, left outdoors, or dropped in water, return it to a Panasonic Service Center.
8. **Do not** pull or carry by cord, use cord as a handle, close a door on cord, or pull cord around sharp edges or corners. Do not run cleaner over cord. Keep cord away from heated surfaces.
9. **Do not** unplug by pulling on cord. To unplug, grasp the plug, not the cord.
10. **Do not** handle plug or cleaner with wet hands.
11. **Do not** put any objects into openings.
12. **Do not** use with any opening blocked; keep free of dust, lint, hair, and anything that may reduce air flow.
13. **Keep** hair, loose clothing, fingers, and all parts of body away from openings and moving parts.
14. **Turn off** all controls before unplugging.
15. **Use extra care** when cleaning on stairs. Do not put on chairs, tables, etc. Keep on floor.
16. **Do not** use cleaner to pick up flammable or combustible liquids (gasoline, cleaning fluid, perfumes, etc.), or use in areas where they may be present. The fumes from these substances can create a fire hazard or explosion.
17. **Do not** pick up anything that is burning or smoking, such as cigarettes, matches, or hot ashes.
18. **Do not** use cleaner without dust bag and/or filters in place.
19. **Connect** to a properly grounded outlet only. See Grounding Instructions.
20. **You** are responsible for making sure that your vacuum cleaner is not used by anyone unable to operate it properly.

## SAVE THESE INSTRUCTIONS

### THIS VACUUM CLEANER IS INTENDED FOR COMMERCIAL USE

**NOTE:** Before you plug in your Panasonic vacuum cleaner, make sure that the voltage indicated on the rating plate located at the back of the vacuum cleaner is the same as your local electrical supply.

## TABLE OF CONTENTS

CONSUMER INFORMATION .....	2
IMPORTANT SAFETY INSTRUCTIONS .....	5
GROUNDING INSTRUCTIONS .....	10
PARTS IDENTIFICATION .....	12
FEATURE CHART .....	13
<b>ASSEMBLY .....</b>	<b>14</b>
Attaching Handle .....	14
Tool Storage .....	16
<b>FEATURES .....</b>	<b>18</b>
Edge Cleaning .....	18
Motor Protector .....	18
<b>TO OPERATE VACUUM CLEANER .....</b>	<b>20</b>
ON-OFF Switch .....	20
Handle Adjustments .....	20
Using Tools .....	22
Tool Usage .....	22
<b>ROUTINE CARE OF VACUUM CLEANER .....</b>	<b>24</b>
Replacing Secondary HEPA Filter .....	24
Changing Dust Bag .....	26
Removing and Installing Lower Plate .....	28
Replacing Belt .....	30
Cleaning Agitator .....	32
Replacing Brushes .....	32
Agitator Assembly .....	34
Cleaning Exterior and Tools .....	34
Removing Clogs .....	36
<b>BEFORE REQUESTING SERVICE .....</b>	<b>38</b>
<b>WARRANTY .....</b>	<b>41, 42</b>
<b>WHAT TO DO WHEN SERVICE IS NEEDED .....</b>	<b>48</b>

# GROUNDING INSTRUCTIONS

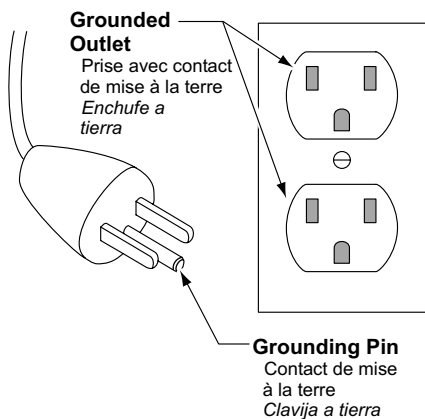

Figure A

This vacuum cleaner must be grounded. If it should malfunction or breakdown, grounding provides a path of least resistance for electric current to reduce the risk of electric shock. This vacuum cleaner is equipped with a cord having an equipment-grounding conductor and grounding plug. The plug must be plugged into an appropriate outlet that is properly installed and grounded in accordance with all local codes and ordinances.

## **⚠ DANGER**

Improper connection of the equipment-grounding conductor can result in a risk of electric shock. Check with a qualified electrician or service person if you are in doubt as to whether the outlet is properly grounded. Do not modify the plug provided with the vacuum cleaner – if it will not fit the outlet, have a proper outlet installed by a qualified electrician.

This vacuum cleaner is for use on a nominal 120-volt circuit, and has a grounding plug that looks like the plug illustrated in **Figure A**. Make sure that this vacuum cleaner is connected to an outlet having the same configuration as the plug.

No adapter should be used with this vacuum cleaner.

**Note:** Before you plug in your commercial vacuum cleaner, make sure that the voltage indicated on the rating plate located at the back of the vacuum cleaner is the same as your local supply.

**PARTS IDENTIFICATION**  
**Nomenclature**  
**Identificación de piezas**

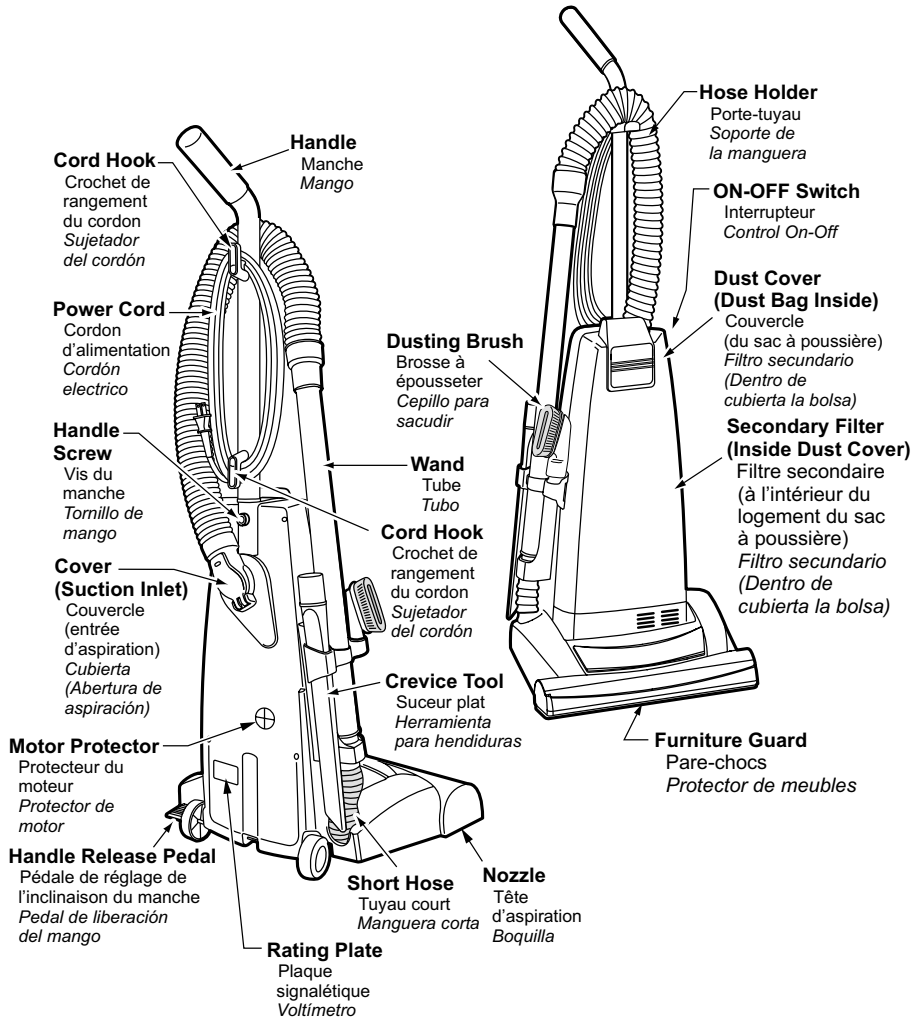

## FEATURE CHART

Power	Tools on Board	Cord Length
120V AC(60Hz)	Yes	50 Ft. (15.25 m)

## Tableau des caractéristiques

Alimentation	Accessoires	Cordon d'alimentation
120 V c.a. (60 Hz)	Oui	15,25 m (50 pi)

## Diagrama de características

<i>Voltaje</i>	<i>Herramientas incluidas</i>	<i>Extensión de cordón</i>
120V AC(60Hz)	4 posición	15,25 m (50 pi)



# ASSEMBLY

## Attaching Handle

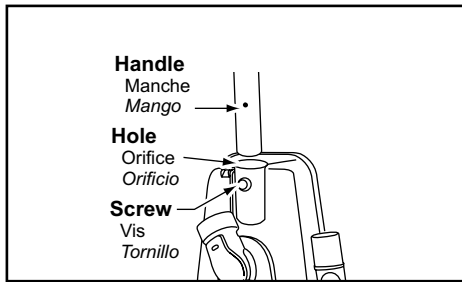

1)

- **DO NOT** plug in until assembly is complete.
- Remove handle screw.
- Insert handle.

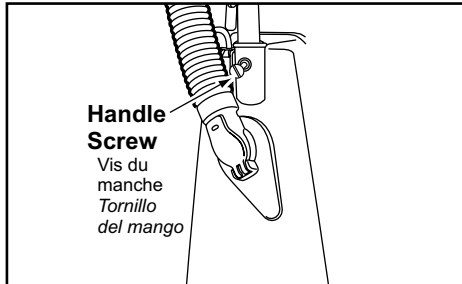

2)

- Insert screw.
- Tighten screw.

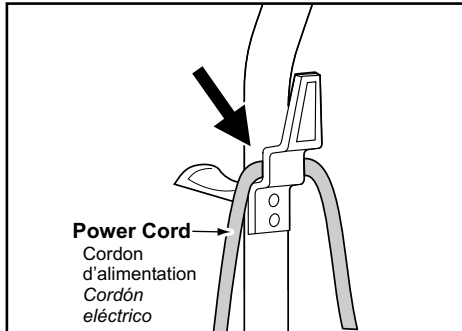

3)

- Push power cord into cord clip.

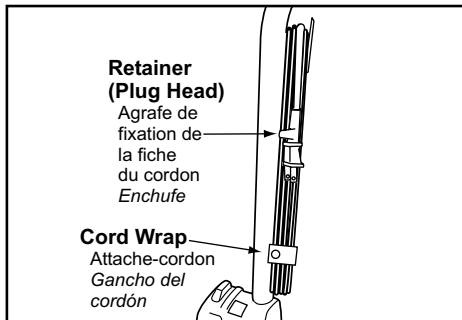

4)

- Wrap power cord around cord hook.
- Secure retainer (plug head) to power cord.

## Tool Storage

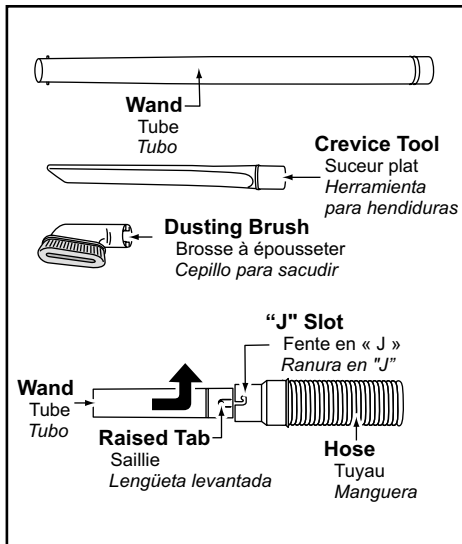

- Some tools may already be stored on vacuum cleaner.
- Place hose in front of handle on hose holder.
- Attach wand to hose by aligning the two (2) raised tabs on wand with "J" slots in hose, guide tabs along grooves, twist to lock in place.
- Place wand in middle slot of tool holder, twisting and pushing down over short hose to assure a good connection.
- Store dusting brush in round front slot of tool holder.
- Place crevice tool into rectangular rear slot of tool holder.
- Refer to PARTS IDENTIFICATION section for tool location.

## FEATURES

### Edge Cleaning

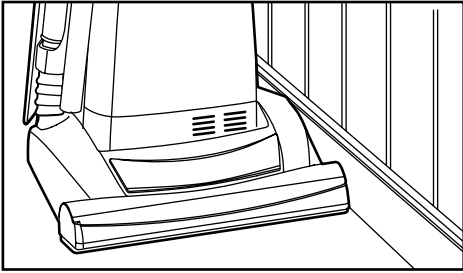

- Edge cleaning feature enables improved cleaning of carpets near walls and furniture.

### Motor Protector

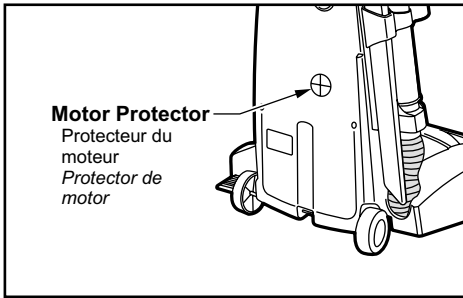

- Automatically opens to provide cooling air to the motor when a clog occurs or when dust bag needs changing.
- Motor protector may open when using tools.
- If motor protector opens, the vacuum cleaner will make a slightly different sound.

**Note:** Do not block motor protector.

## TO OPERATE VACUUM CLEANER

### ON-OFF Switch

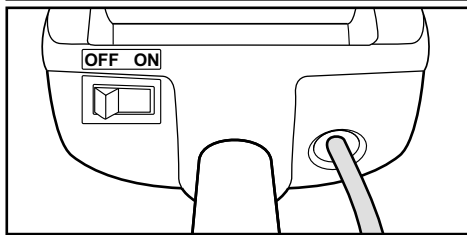

- Ensure ON-OFF switch is OFF.
- Plug the power cord into 120V outlet.
- ON position turns vacuum cleaner on.
- OFF position turns vacuum cleaner off.

### Handle Adjustments

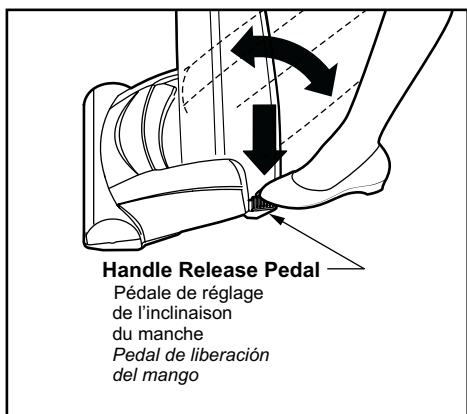

- Step on handle release pedal to change handle position.
- Move vacuum cleaner to upright position for storage and tool use.
- Move vacuum cleaner to middle position for normal use.
- Use low position for cleaning under furniture.

## Using Tools

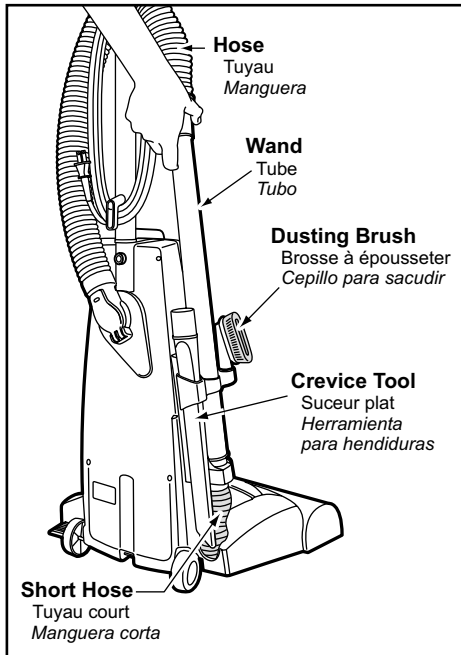

### CAUTION

If tools are used, and vacuum cleaner is left in upright position, carpet damage could occur.

Agitator rotates when using tools, use care to ensure that nothing comes into contact with agitator.

- Remove wand from short hose by twisting and pulling up.
- The tools can be attached to hose, wand or crevice tool.
- **DO NOT** overextend your reach with hose as it could tip vacuum cleaner.
- Place all tools and hose back in the same manner as shown in **TOOL STORAGE**.

## Tool Usage

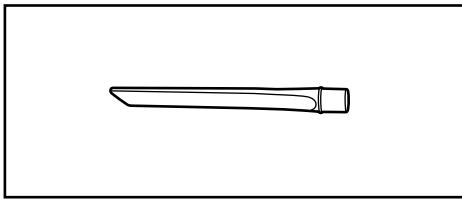

- The Crevice Tool may be used on the following items:

- Furniture
- Cushions
- Drapes
- Stairs
- Walls

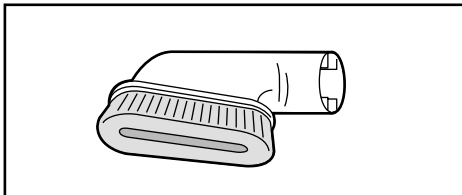

- The Dusting Brush may be used on the following items:

- Furniture
- Drapes
- Stairs
- Walls

## ROUTINE CARE OF VACUUM CLEANER

Performing the following tasks will keep your new Panasonic vacuum cleaner operating at peak performance levels and will ensure these high levels for years to come. Check the **BEFORE REQUESTING SERVICE** section in this manual for recommendations on performing some of these tasks to help solve various problems that may occur.

### Replacing Secondary HEPA Filter

#### Secondary HEPA Filter (White Side Up)

Filtre secondaire de type HEPA  
(Côté blanc sur le dessus)  
Filtro de HEPA secundario  
(Blanca hacia arriba)

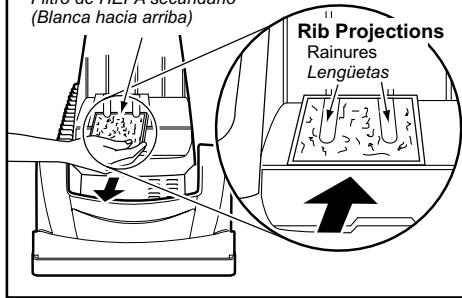

- Secondary HEPA filter protects the motor.
- Check filter when installing a new dust bag.
- If dirty, pull filter from bottom of dust compartment and replace.
- Place new filter, white side up, in dust compartment, **DO NOT CLEAN WITH WATER\***.
- Ensure filter is fully inserted under plastic ribs.

\*Filter cannot be cleaned and should be replaced at least once each year.

## Changing Dust Bag

Always operate vacuum cleaner with genuine Panasonic Type U3 Standard or U6 Electrostatic dust bags installed. Panasonic dust bags may be purchased through any authorized Panasonic dealer or ordered from service company.

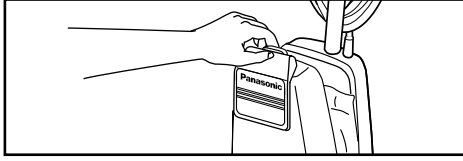

1)

- Pull outward on dust cover grip to remove the dust cover.

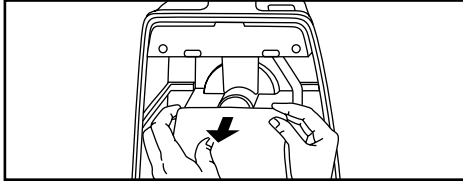

2)

- Remove dust bag by grasping cardboard portion and pulling out.

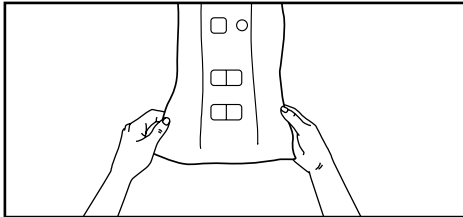

3)

- Spread out new dust bag, taking care not to tear bag.

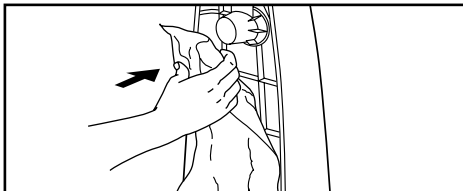

4)

- Attach new dust bag onto bag holder by holding cardboard portion and pushing back.

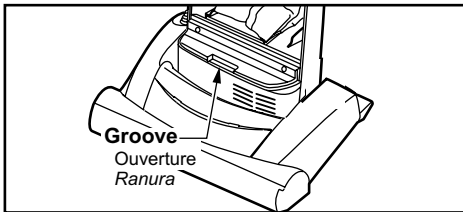

5)

- Reinsert tab on end of dust cover into groove on dust compartment to allow cover to rotate closed.

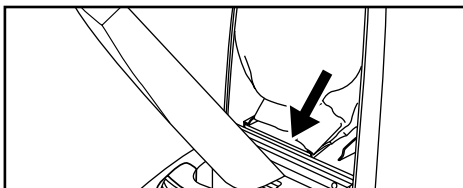

6)

- Rotate dust cover up into closed position and press into place without pinching dust bag.

**⚠ WARNING** Electrical Shock or Personal Injury Hazard

Disconnect the electrical supply before servicing or cleaning the unit. Failure to do so could result in electrical shock or personal injury from cleaner suddenly starting.

**Removing and Installing Lower Plate**

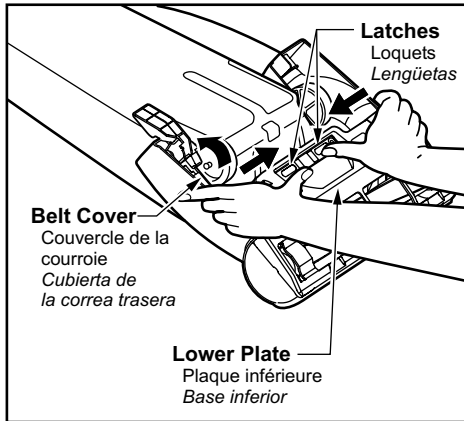

- **Before servicing any parts, disconnect vacuum cleaner from electrical outlet.**
- **Place paper under nozzle whenever lower plate is removed to protect floor.**
- **Place handle in upright position and turn vacuum cleaner over to expose lower plate.**
- **Release lower plate by pressing two (2) latches inward.**
- **Remove lower plate and remove any residue that may exist in belt area.**

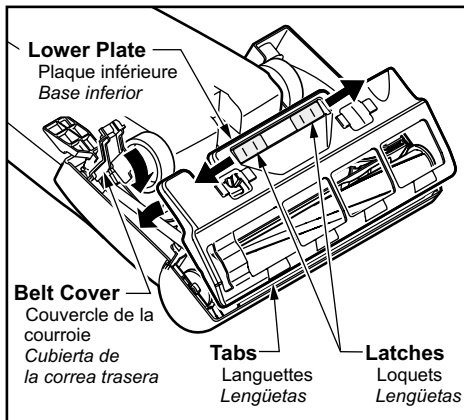

- **Lift belt cover to replace belt if necessary. (See Replacing Belt page 30).**
- **Close the rear belt cover and reinstall lower plate by hooking front end of lower plate into the front of nozzle housing.**
- **Make sure all wires are routed properly and not pinched.**
- **Press lower plate into place then push two (2) latches outward.**



## Replacing Belt

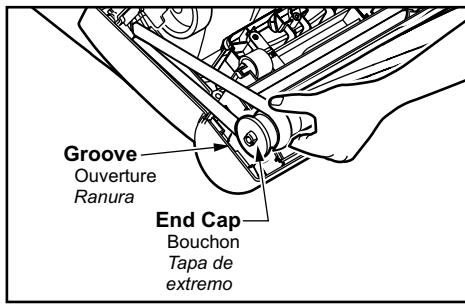
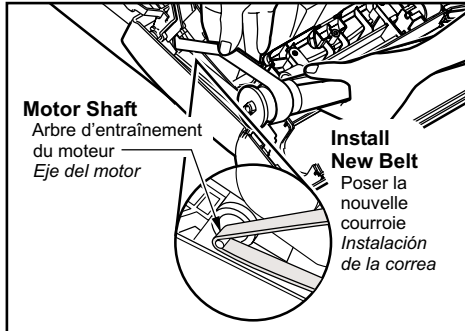
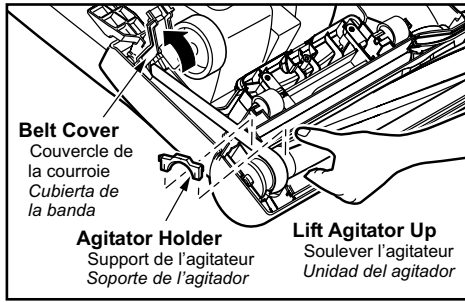

- Replace belt whenever a burning rubber smell caused by excessive slippage occurs.
- Remove lower plate.
- Lift rear belt cover and remove agitator holder.
- Remove agitator by carefully lifting out.
- Remove worn or broken belt.
- Clean agitator.
- Loop new belt (Panasonic Type UB8 only) around motor shaft and agitator pulley.
- Reinstall agitator back into nozzle housing grooves.
- Close rear belt cover and reinstall agitator.
- After reinstalling the agitator, turn it by hand to make sure that belt is not twisted or pinched and that all rotating parts turn freely.
- Reinstall lower plate. (See Removing and Installing Lower Plate, page 28).

## Cleaning Agitator

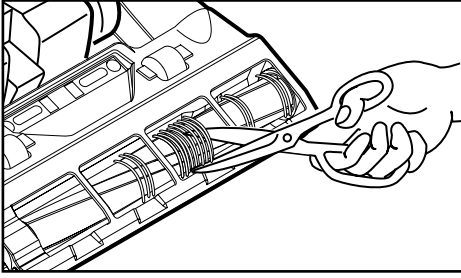

- Clean agitator after every five uses and every time the belt is replaced.
- Remove lower plate.
- Cut off any carpet pile and lint entangled around agitator with a pair of scissors.
- Remove agitator.
- Remove any string or debris located on the end caps, washers or agitator shaft.
- Reinstall agitator and lower plate.

## Replacing Brushes

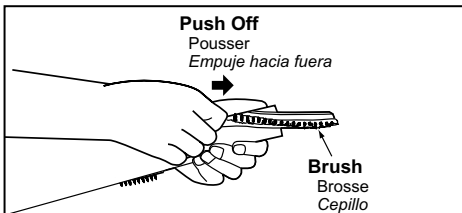
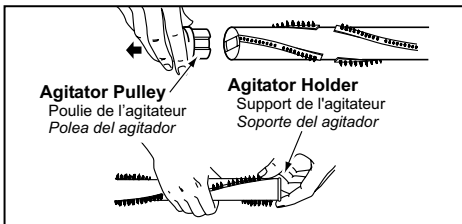
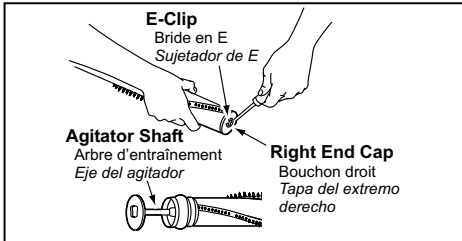
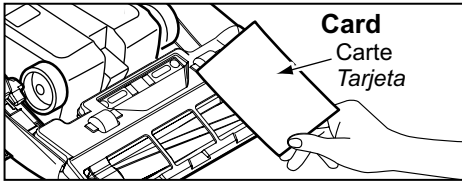

- When the bristles on the agitator are worn so that they do not touch a card held across the lower plate, the brushes should be replaced.
- Remove lower plate and agitator.
- Remove the E-clip from agitator shaft and end cap.
- Do not bend agitator shaft or lose E-clip or spacer.
- Pull agitator shaft out of agitator body.
- Pull, or pry out, agitator holder and agitator pulley.
- Push each brush out of agitator body as shown.
- Install new brushes by reversing procedure.
- Reinstall agitator holder and agitator pulley completely.
- Reinstall the agitator shaft, end cap and E-clip.
- See exploded view for correct assembly of parts.
- Position belt over agitator pulley on the agitator.
- Reinstall agitator and lower plate.

## Agitator Assembly

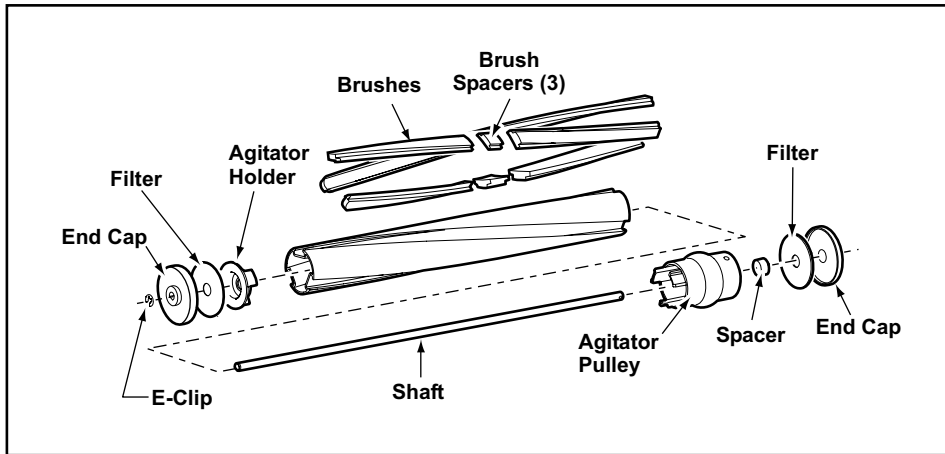

## Cleaning Exterior and Tools

- Unplug cord from wall outlet.
- Clean exterior using a clean, soft cloth that has been dipped in a solution of mild liquid detergent and water and wrung dry.
- DO NOT drip water on vacuum cleaner; wipe dry after cleaning.
- DO NOT clean tools in dishwasher or clothes washer.
- Wash tools in warm soapy water, rinse and air dry.
- DO NOT use tools if they are wet.

## Removing Clogs

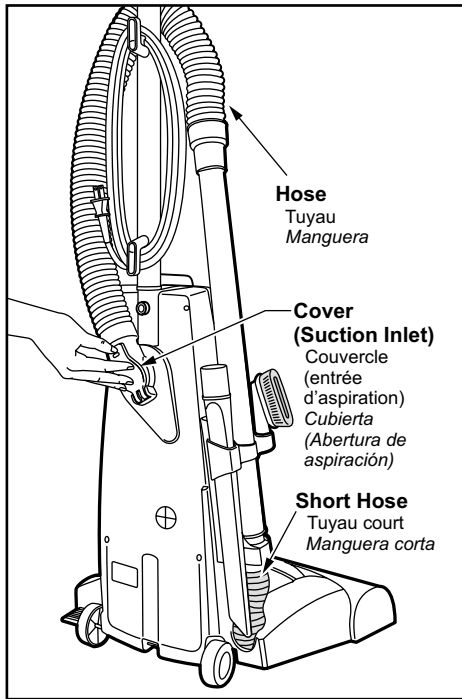

The hose located on the back of the vacuum cleaner carries the dirt from the nozzle up to the dust bag. If the hose should become clogged:

- Unplug vacuum.
- Pull open suction inlet cover and check for clogging.
- Disconnect wand from short hose and check wand and hose.
- Plug in vacuum cleaner and turn on.
- Disconnect wand and stretch hose in and out to remove clog.
- If clog still exists, turn vacuum cleaner OFF and **UNPLUG POWER CORD.**
- Remove lower plate.
- Remove short hose from nozzle by lifting straight up.
- Inspect hose end and clear any obstructions.
- Reinstall short hose and lower plate.

## BEFORE REQUESTING SERVICE

### **WARNING** Electrical Shock or Personal Injury Hazard

Disconnect the electrical supply before servicing or cleaning the unit. Failure to do so could result in electrical shock or personal injury from cleaner suddenly starting.

Review this chart to find do-it-yourself solutions for minor performance problems. Any service needed, other than those described in these Operating Instructions, should be performed by an authorized service representative.

PROBLEM	POSSIBLE CAUSE	POSSIBLE SOLUTION
<b>Cleaner will not run.</b>	<ol style="list-style-type: none"> <li>1. Unplugged at wall outlet.</li> <li>2. ON-OFF switch not turned on.</li> <li>3. Tripped circuit breaker/blown fuse at household service panel.</li> </ol>	<ol style="list-style-type: none"> <li>1. Plug in firmly. Push ON-OFF switch to ON.</li> <li>2. Push ON-OFF switch to ON.</li> <li>3. Reset circuit breaker or replace fuse.</li> </ol>
<b>Poor job of dirt pickup.</b>	<ol style="list-style-type: none"> <li>1. Full or clogged dust bag.</li> <li>2. Broken belt.</li> <li>3. Clogged hose or nozzle.</li> <li>4. Hose not inserted fully.</li> <li>5. Worn brushes.</li> <li>6. Hole in hose.</li> <li>7. Dust cover improperly installed.</li> <li>8. Belt not installed on motor shaft.</li> </ol>	<ol style="list-style-type: none"> <li>1. Change bag.</li> <li>2. Replace belt.</li> <li>3. Clean hose or nozzle area.</li> <li>4. Insert hose.</li> <li>5. Replace brushes.</li> <li>6. Replace hose.</li> <li>7. Properly install dust cover.</li> <li>8. Install belt on motor shaft.</li> </ol>
<b>Dust escapes the paper bag.</b>	<ol style="list-style-type: none"> <li>1. Bag improperly installed.</li> <li>2. Bag torn.</li> </ol>	<ol style="list-style-type: none"> <li>1. Properly install bag.</li> <li>2. Replace bag.</li> </ol>

# WARRANTY

## Panasonic Commercial Vacuum Cleaner Limited Warranty

Panasonic Home and Commercial Products Company (referred to as "the warrantor") will repair this product with new or refurbished parts free of charge, in the U.S.A. or Puerto Rico, for one (1) year from the date of original purchase, in the event of a defect in materials or workmanship.

**This Limited Warranty Excludes both Labor and Parts for the following items:** disposable dust bags, filters, belts, light bulbs, agitator brushes and batteries (if supplied).

Carry-in or mail-in service in the U.S.A. can be obtained during the warranty period by contacting a Panasonic Services Company (PASC) Factory Servicenter listed in the Servicenter Directory, or by calling toll free, 1-888-350-9590, or by contacting your selling distributor. Carry-in or mail-in service in Puerto Rico can be obtained during the warranty period by calling the local Panasonic Sales Company telephone number listed in the Servicenter Directory.

This warranty is extended only to the original purchaser. A purchase receipt or other proof of date of original purchase will be required before warranty performance is rendered.

This warranty only covers failures due to defects in materials and workmanship which occur during normal use and does not cover damages which occur in shipment, or failures which are caused by products not supplied by the warrantor, or failures which result from accident, misuse, abuse, neglect, mishandling, misapplication, faulty installation, improper operation or maintenance, alteration, modification, power line surge, improper voltage supply, lightning damage, or service by anyone other than a Panasonic Authorized Servicenter, or damage that is attributable to acts of God.

### **LIMITS AND EXCLUSIONS:**

There are no express warranties except as listed above.

THE WARRANTOR SHALL NOT BE LIABLE FOR INCIDENTAL OR CONSEQUENTIAL DAMAGES RESULTING FROM THE USE OF THIS PRODUCT, OR ARISING OUT OF ANY BREACH OF THIS WARRANTY. ALL EXPRESS AND IMPLIED WARRANTIES, INCLUDING THE WARRANTIES OF MERCHANTABILITY AND FITNESS FOR A PARTICULAR PURPOSE, ARE LIMITED TO THE APPLICABLE WARRANTY PERIOD SET FORTH ABOVE.

Some states do not allow the exclusion or limitation of incidental or consequential damages, or limitations on how long an implied warranty lasts, so the above exclusions or limitations may not apply to you.

This warranty gives you specific legal rights and you may also have other rights which vary from state to state. If a problem with this product develops during or after the warranty period, you may contact your dealer or Servicenter. If the problem is not handled to your satisfaction, then write to the Customer Satisfaction Center at the listed address on the back cover.

# WARRANTY

**Panasonic Canada Inc.**  
5770 Ambler Drive, Mississauga, Ontario L4W 2T3

## PANASONIC PRODUCT - LIMITED WARRANTY

Panasonic Canada Inc. warrants this product to be free from defects in material and workmanship and agrees to remedy any such defect for a period as stated below from the date of original purchase.

### Commercial Vacuum Cleaner - Ninety (90) days parts and labour

#### LIMITATIONS AND EXCLUSIONS

This warranty does not apply to products purchased outside Canada or to any product which has been improperly installed, subjected to usage for which the product was not designed, misused or abused, damaged during shipping, or which has been altered or repaired in any way that affects the reliability or detracts from the performance. Parts such as disposable dust bags, filters, belts, light bulbs and agitator brushes are also excluded from coverage under this warranty.

This warranty is extended to the original end user purchaser only. A purchase receipt or other proof of date of original purchase is required before warranty service is performed.

**THIS EXPRESS, LIMITED WARRANTY IS IN LIEU OF ALL OTHER WARRANTIES, EXPRESS OR IMPLIED, INCLUDING ANY IMPLIED WARRANTIES OF MERCHANTABILITY AND FITNESS FOR A PARTICULAR PURPOSE.**

**IN NO EVENT WILL PANASONIC CANADA INC. BE LIABLE FOR ANY SPECIAL, INDIRECT OR CONSEQUENTIAL DAMAGES.**

In certain instances, some jurisdictions do not allow the exclusion or limitation of incidental or consequential damages, or the exclusion of implied warranties, so the above limitations and exclusions may not be applicable.

#### WARRANTY SERVICE

**FOR PRODUCT OPERATION ASSISTANCE, please contact:**

**Our Customer Care Centre:** Telephone #: (905) 624-5505  
1-800 #: 1-800-561-5505  
Fax #: (905) 238-2360  
Email link: "Contact Us" on [www.panasonic.ca](http://www.panasonic.ca)

**FOR PRODUCT REPAIRS,** please locate your nearest Authorized Servicentre at [www.panasonic.ca](http://www.panasonic.ca) :

Link : "Servicentres™ locator" under "Customer support"

#### Panasonic Factory Service:

##### **Vancouver**

Panasonic Canada Inc.  
12111 Riverside Way  
Richmond BC V6W 1K8  
Tel: (604) 278-4211  
Fax: (604) 278-5627

##### **Toronto**

Panasonic Canada Inc.  
5770 Ambler Drive  
Mississauga ON L4W 2T3  
Tel: (905) 624-8447  
Fax: (905) 238-2418

#### **IF YOU SHIP THE PRODUCT TO A SERVICENTRE**

Carefully pack and send prepaid, adequately insured and preferably in the original carton.  
Include details of the defect claimed, and proof of date of original purchase.