

This Owner's Manual is provided and hosted by [Appliance Factory Parts](#).



GE JX1527CSH Owner's Manual

[Shop genuine replacement parts for GE JX1527CSH](#)



[Find Your GE Microwave Parts - Select From 3055 Models](#)

----- Manual continues below -----

Installation Instructions

Built-In Trim Kits

JX1527 and JX1530

? Questions? Call 800.GE.CARES (800.432.2737) or Visit our Website at: www.GEAppliances.com

BEFORE YOU BEGIN

Read these instructions completely and carefully.







- **IMPORTANT** — Save these instructions for local inspector's use.
- **IMPORTANT** — Observe all governing codes and ordinances.
- **Note to Installer** – Be sure to leave these instructions with the Consumer.
- **Note to Consumer** – Keep these instructions for future reference.
- **Skill level** – Installation of this appliance requires basic mechanical and electrical skills.
- **Completion time** – 1 to 3 hours
- Proper installation is the responsibility of the installer.
- Product failure due to improper installation is not covered under the Warranty.
- This kit is UL listed for installation alone or over any General Electric/Hotpoint/RCA single electric wall oven.
- For easier installation and personal safety, we recommend that two people install this microwave oven.
- Unplug the microwave oven before attempting installation of this kit.

⚠ WARNING — This appliance must be properly grounded.

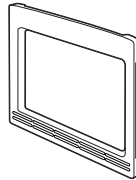
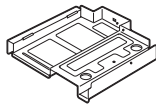
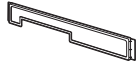
FOR YOUR SAFETY:

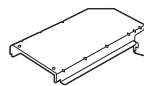
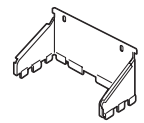
⚠ WARNING — Before beginning the installation, switch power off at service panel and lock the service disconnecting means to prevent power from being switched on accidentally. When the service disconnecting means cannot be locked, securely fasten a prominent warning device, such as a tag, to the service panel.

PARTS INCLUDED

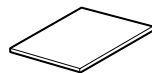
PART		QUANTITY
	Trim Frame	1
	Bottom Duct	1
	Top Bracket	1
	Bottom Bracket	1
	Upper Duct	1
	Rear Duct	1
	Phillips Round-Head Screws (bronze)	24 (22 required for installation)
	Phillips Flat-Head Screws (steel)	6 (4 required for installation)
	Anti-Tip Brace	1
	Anti-Tip Bracket	1
	Template	1

**READ CAREFULLY.
KEEP THESE INSTRUCTIONS.**

Installation Instructions

TOOLS YOU WILL NEED

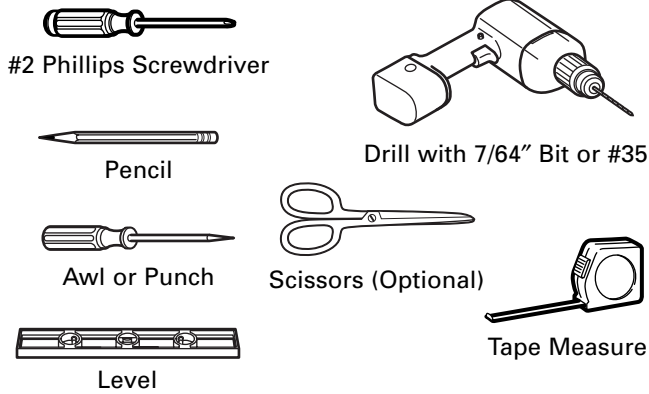

1 CUTOUT DIMENSIONS

Models	27"	30"
Height	18 ³ / ₄ "	18 ³ / ₄ "
Width	24" ± 1/16"	24" ± 1/16"
Depth (min.)*	21 ¹ / ₂ " or 23"	21 ¹ / ₂ " or 23"

* Min. depth with receptacle outside cabinet 21¹/₂"
 Min. depth with receptacle inside cabinet 23"

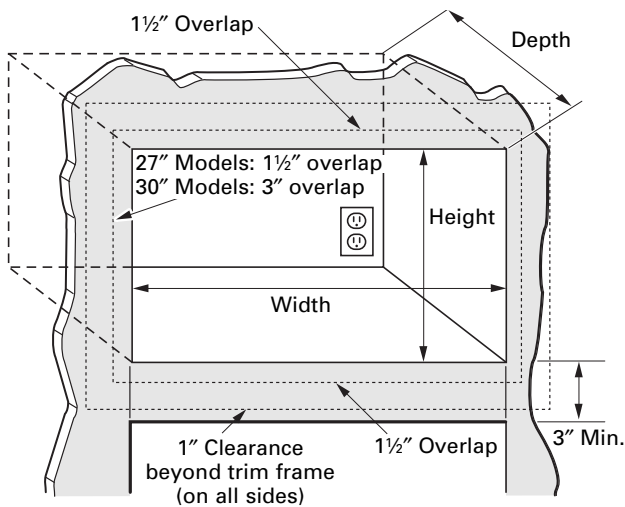

⚠ WARNING — This trim kit uses air flow from the top, bottom and sides of the trim frame. Blocking the air flow can cause the microwave to function improperly and may cause damage to the microwave.

Allow a 1" clearance beyond the edge of the trim frame to provide proper air flow.

1 CUTOUT DIMENSIONS (CONT.)

On 27" models, allow 1¹/₂" on all sides for overlap of the trim frame over the edges of the cutout.

On 30" models, allow 1¹/₂" at the top and bottom and 3" on each side for overlap of the trim frame over the edges of the cutout.

FOR INSTALLATION ABOVE A BUILT-IN OVEN:

Microwave oven should be installed on a 3/8" plywood base and supported by 2x4 or 1x2 equivalent runners on all sides. Base must be capable of supporting a minimum of 100 lbs.

2 INSTALL THE ANTI-TIP BRACE

A Draw a line on the cutout floor at the center of the cutout, and extend the line 1/2" down the face of the cabinet.

B Fold or cut the front edge of the template, along the front guide line. Place the template flush along the front edge of the cutout floor, aligning the center line of the template with the center line of the cutout floor. Mark the centers of the two screw holes with an awl or center punch for the anti-tip brace location as shown.

DIMENSIONS:

A = 1³/₁₆"
 B = 3"
 C = 20¹/₁₆"

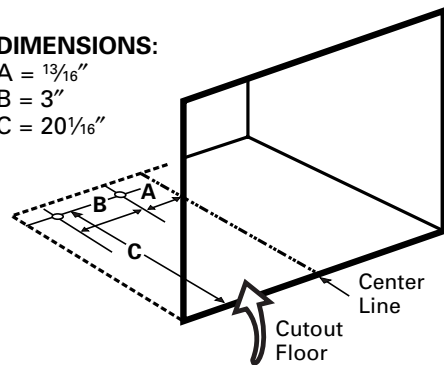

C Remove the template and drill two holes for the anti-tip brace.

D Install the anti-tip brace onto the cutout floor using two round-head screws.

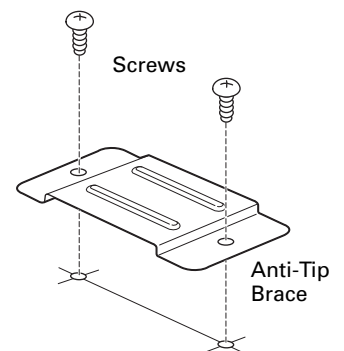

Installation Instructions

3 INSTALL BOTTOM DUCT ASSEMBLY TO MICROWAVE OVEN

- A** Fasten the anti-tip bracket to the bottom duct using four round-head screws.

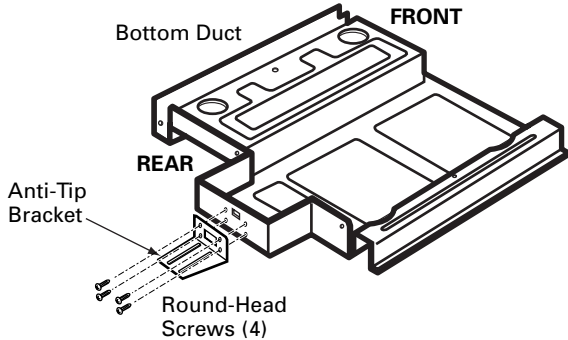

- B** Install the rear duct to the bottom duct with one round-head screw. Turn the microwave oven upside down.

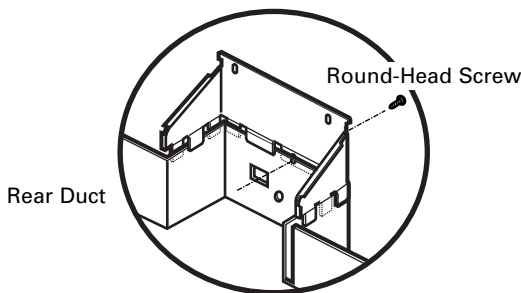

- C** Remove a screw from right side (control side) of microwave oven cabinet. Place the bottom duct assembly on the microwave bottom and fasten with six round-head screws and the screw just removed from the side of the microwave. Turn the microwave oven right side up, being careful not to bend the bottom duct flange.

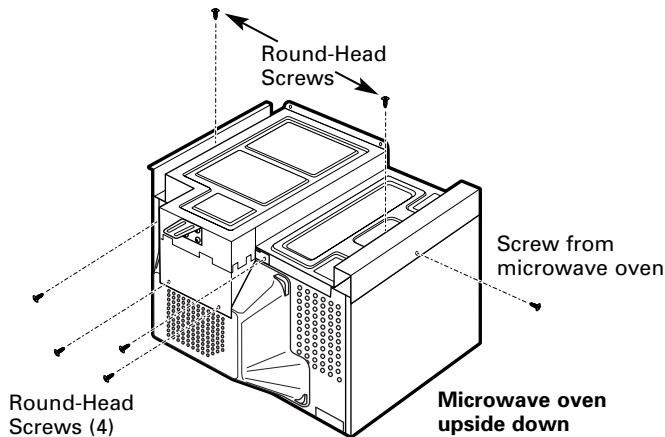

4 INSTALL UPPER DUCT AND TOP BRACKET

- A** Remove two screws from back of the microwave oven. Peel off the adhesive backing from the upper duct and secure it to the microwave oven by pressing it firmly down on duct. Fasten the upper duct with the two screws just removed from the microwave oven.

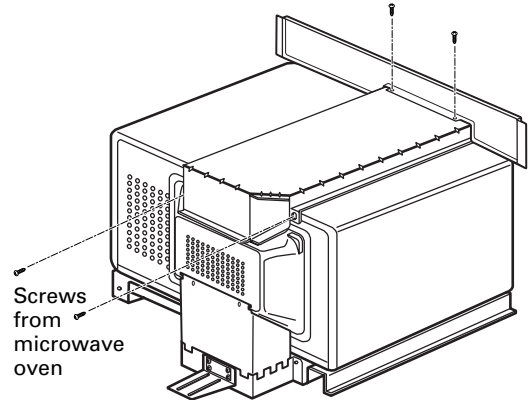

- B** Place the top bracket on top of the upper duct, with the opening on the top bracket lined up with the opening on the duct. Attach the top bracket to the upper duct using two round-head screws.

5 INSTALL MICROWAVE OVEN INTO CABINET

- A** Slide the microwave oven part way into the cabinet opening.

- B** Plug in the microwave oven.

- C** The anti-tip bracket must be flat to the cutout floor to engage correctly with the anti-tip brace as shown. Carefully slide the microwave oven back, engaging the anti-tip brace. Make sure the power cord is not mashed or cut as you slide the microwave into place.

- D** Center the microwave oven within the cutout opening.

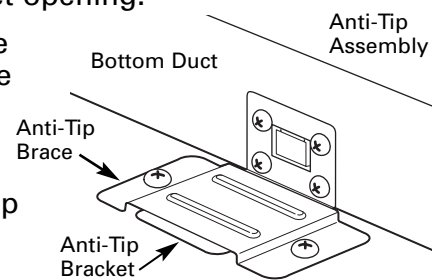

Installation Instructions

6 CHECK LEVELING

Check the leveling by placing a level at the front and sides of the microwave. It may be necessary to add wood shims under the bottom duct to level the microwave front-to-back or side-to-side.

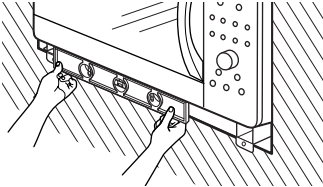

7 INSTALL THE BOTTOM BRACKET AND SECURE THE TOP BRACKET

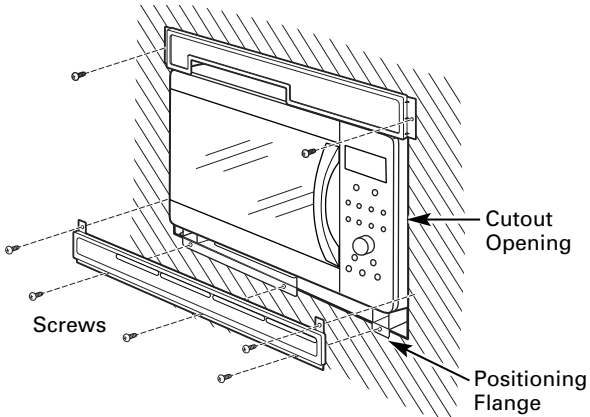

- A** Drill pilot holes through the three holes on the front flange of the bottom duct assembly.
- B** Hold the bottom bracket against the front flange of the bottom duct assembly, lining up the three holes in the bottom bracket with the three holes in the bottom duct. Screw in three round-head screws. Drill pilot holes through the two holes in the tabs on the sides of the bottom bracket. Screw in two round-head screws.
- C** Drill pilot holes through the holes in the top bracket. Secure the top bracket to the cabinet using two round-head screws.

8 INSTALL THE TRIM FRAME

- A** Place the trim frame over the microwave oven with the vent openings at the bottom.
- B** Press the trim frame into the opening until all sides snap into place.

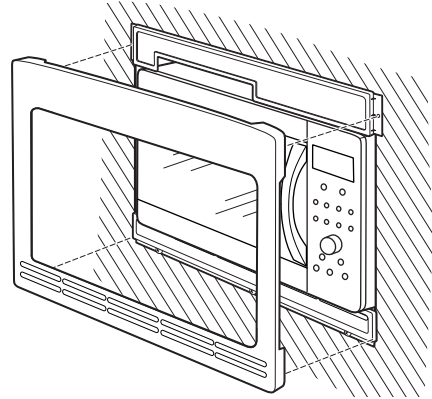

- C** Open the microwave oven door. Secure the trim frame using four flat-head screws (two on the inside top and two on the inside bottom).

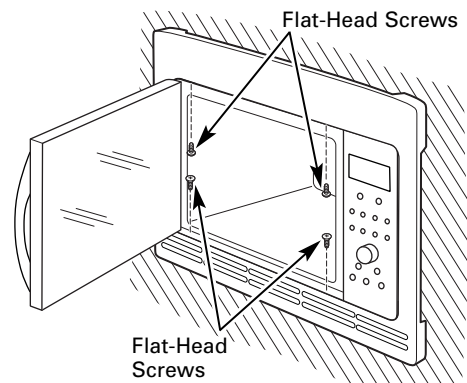

9 REPLACE ANY LOOSE ITEMS

- A** Your trim kit is now fully installed. Replace any loose items that were removed from the inside of the microwave oven. Save or discard the extra screws. Do not place them in the microwave oven.
- B** Keep these installation instructions for future reference.
- C** Replace house fuse or close circuit breaker to restore power at the service panel.

164D3370P334
49-40408

3828W5U0334
10-03 JR

Printed in Korea