

This Owner's Manual is provided and hosted by [Appliance Factory Parts](#).



WHIRLPOOL MK1150XPS Owner's Manual

[Shop genuine replacement parts for WHIRLPOOL
MK1150XPS](#)



[Find Your WHIRLPOOL Microwave Parts - Select From 1350 Models](#)

----- Manual continues below -----

MICROWAVE OVEN BUILT-IN TRIM KIT INSTALLATION INSTRUCTIONS

Built-In Trim Kit Models MK1150XP, MK1154XP, MK1157XP

UL listed for use over built-in electric ovens:

24" (60.96 cm): RBS245PD, KEBI141D, KEBS147D

27" (68.6 cm): (Y)RBS275PD, (Y)GBS277PD, KEBI171D, (Y)KEBS177D

30" (76.2 cm): (Y)RBS305PD, GBS307PD, (Y)KEBI101D, (Y)KEBS107D

INSTRUCTIONS D'INSTALLATION GARNITURE ENCASTRÉE POUR FOUR À MICRO-ONDES

Garniture pour modèles MK1150XP, MK1154XP, MK1157XP

Homologations UL pour utilisation

au-dessus des fours encastrés électriques :

24" (60,96 cm) : RBS245PD, KEBI141D, KEBS147D

27" (68,6 cm) : (Y)RBS275PD, (Y)GBS277PD, KEBI171D, (Y)KEBS177D

30" (76,2 cm) : (Y)RBS305PD, GBS307PD, (Y)KEBI101D, (Y)KEBS107D

Table of Contents / Table des matières

MICROWAVE OVEN SAFETY	2	SÉCURITÉ DU FOUR À MICRO-ONDES	5
INSTALLATION INSTRUCTIONS	2	INSTRUCTIONS D'INSTALLATION	6
Tools Recommended.....	2	Outillage recommandé	6
Parts Supplied.....	2	Pièces fournies	6
Cutout Dimensions	2	Dimensions pour le découpage	6
Electrical Requirements	3	Spécifications électriques	6
Microwave Oven Preparation	3	Préparation du four à micro-ondes	7
Bottom Duct Assembly.....	3	Assemblage du conduit du bas	7
Side Duct and Upper Duct Assembly.....	3	Assemblage du conduit latéral et du conduit supérieur	7
Anti-Tip Bracket Installation.....	4	Installation de la bride antibasculement	8
Microwave Oven Placement.....	4	Mise en place du four à micro-ondes	8
Trim Kit Frame Installation	5	Installation du cadre de garniture.....	8

IMPORTANT: Save Installation Instructions for local electrical inspector's use.

IMPORTANT : Conserver ces instructions d'installation à l'usage de l'inspecteur local des installations électriques.

MICROWAVE OVEN SAFETY

Your safety and the safety of others are very important.

We have provided many important safety messages in this manual and on your appliance. Always read and obey all safety messages.



This is the safety alert symbol.

This symbol alerts you to potential hazards that can kill or hurt you and others.

All safety messages will follow the safety alert symbol and either the word "DANGER" or "WARNING." These words mean:

! DANGER

You can be killed or seriously injured if you don't immediately follow instructions.

! WARNING

You can be killed or seriously injured if you don't follow instructions.

All safety messages will tell you what the potential hazard is, tell you how to reduce the chance of injury, and tell you what can happen if the instructions are not followed.

INSTALLATION INSTRUCTIONS

Tools Recommended

Gather the required tools and parts before starting installation. Read and follow the instructions provided with any tools listed here.

- Measuring tape
- #2 Phillips screwdriver
- Pencil
- 5/64" drill
- Scissors

Parts Supplied

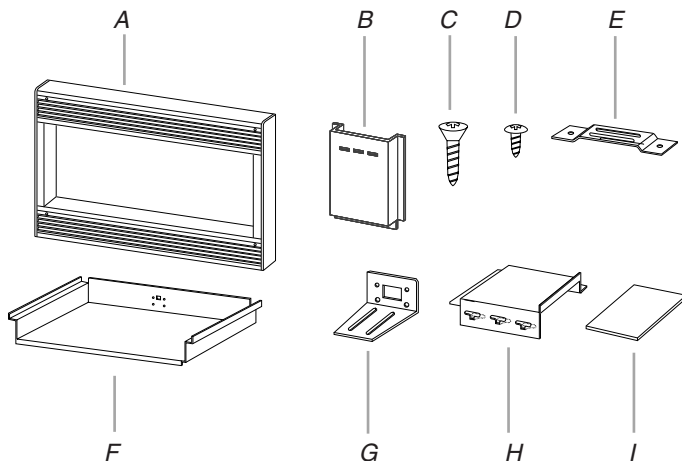

A. Trim kit frame

B. Side duct (1)

C. 1" screws (4, plus 2 extra)

D. 1/2" screws (15, plus 2 extra)

E. Anti-tip bracket (1)

F. Bottom duct (1)

G. Bottom bracket (1)

H. Upper duct (1)

I. Template (1)

Cutout Dimensions

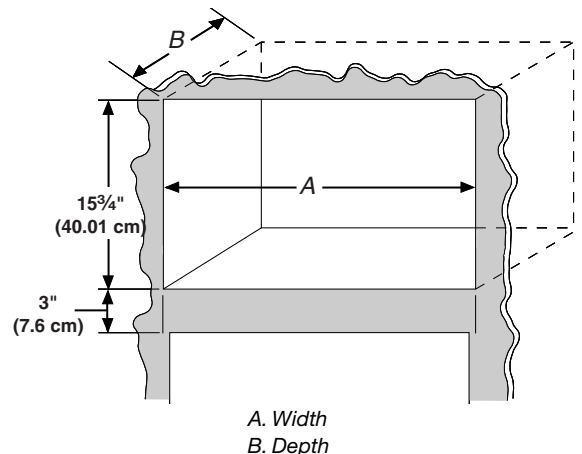

DIM.	OVER 24" (61.0 CM) BUILT-IN OVEN	OVER 27" (68.6 CM) BUILT-IN OVEN	OVER 30" (76.2 CM) BUILT-IN OVEN
Width	22½" (57.15 cm)	25½" (64.77 cm)	25½" (64.77 cm) min; 28½" (72.39 cm) max.
Depth	18½" (46.99 cm) min. with flush mount receptacle; 19" (48.26 cm) min. without flush mount receptacle		
Height	15¾" (40.01 cm) (for all models)		

Electrical Requirements

⚠️ WARNING



Electrical Shock Hazard

Plug into a grounded 3 prong outlet.

Do not remove ground prong.

Do not use an adapter.

Do not use an extension cord.

Failure to follow these instructions can result in death, fire, or electrical shock.

Observe all governing codes and ordinances. A 120-Volt, 60-Hz, AC-only, 15- or 20-amp fused electrical supply (or circuit breaker) is required. (A time-delay fuse or circuit breaker is recommended.) It is recommended that a separate circuit serving only this appliance be provided.

GROUNDING INSTRUCTIONS

■ For all cord connected appliances:

The microwave oven must be grounded. In the event of an electrical short circuit, grounding reduces the risk of electric shock by providing an escape wire for the electric current. The microwave oven is equipped with a cord having a grounding wire with a grounding plug. The plug must be plugged into an outlet that is properly installed and grounded.

WARNING: Improper use of the grounding plug can result in a risk of electric shock. Consult a qualified electrician or serviceman if the grounding instructions are not completely understood, or if doubt exists as to whether the microwave oven is properly grounded.

Do not use an extension cord. If the power supply cord is too short, have a qualified electrician or serviceman install an outlet near the microwave oven.

SAVE THESE INSTRUCTIONS

Microwave Oven Preparation

1. Unplug microwave oven before proceeding with installation.
2. Remove any loose items inside microwave oven.

Bottom Duct Assembly

1. Fasten bottom bracket to bottom duct using two ½" screws.

(Rear view of bottom duct)

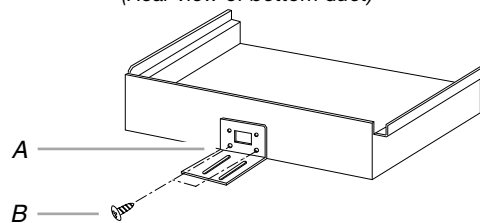

A. Bottom bracket
B. ½" screws

2. Remove 2 existing screws from right side of microwave oven, and 1 existing screw from left side.
3. Install bottom duct with 2 existing screws on right side of oven.

(Front view of microwave oven)

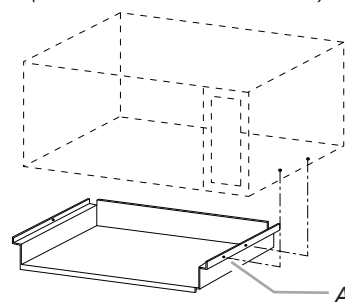

A. Existing screws

Side Duct and Upper Duct Assembly

1. Connect side duct to upper duct:
Insert projecting tabs of upper duct into holes of side duct. Then bend tabs upward.

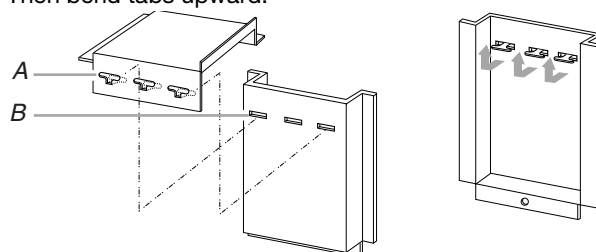

A. Tabs of upper duct
B. Holes in side duct

NOTE: Remove any dirt or oil on microwave oven surface before ducts are attached.

2. Peel off backing of double-sided tape. Align the duct assembly screw hole to the existing screw hole on left side of microwave oven, and attach the duct assembly to the oven. Press down firmly on ducts, then fasten with existing screw.

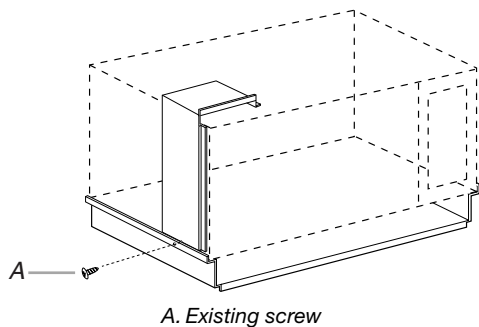

A. Existing screw

Anti-Tip Bracket Installation

1. On cutout floor, use template to mark hole centers for anti-tip bracket. Be sure to align the centerline of template to centerline of cutout floor.

(Dimensions as shown are not to scale.)

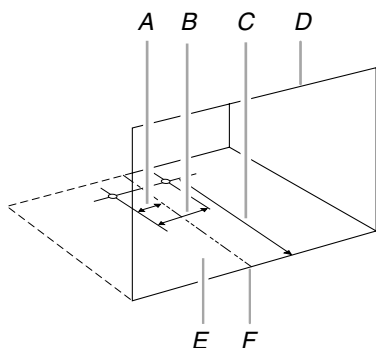

A. 1 1/2" (3.81 cm) D. Cutout opening
 B. 3" (7.62 cm) E. Cutout floor
 C. 16" (40.64 cm) F. Centerline

2. Drill 2 holes for anti-tip bracket. (Use 5/64" drill.)
3. Install anti-tip bracket onto cutout floor using two 1/2" screws.

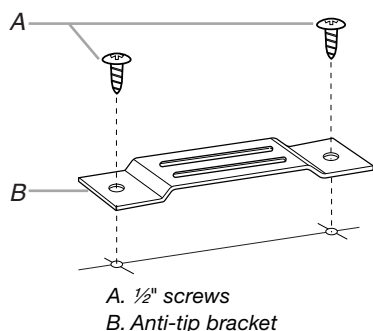

A. 1/2" screws
 B. Anti-tip bracket

Microwave Oven Placement

1. Slide microwave oven partway into cutout opening.
NOTE: Bottom bracket must be flat against cutout floor in order to correctly engage with anti-tip bracket.

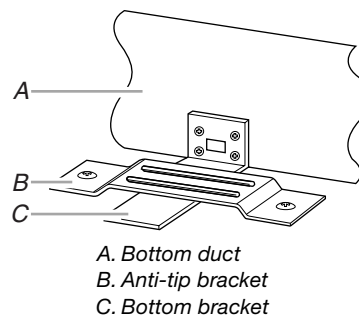

A. Bottom duct
 B. Anti-tip bracket
 C. Bottom bracket

2. Plug in microwave oven.
3. Make sure microwave oven is centered within cutout opening and slide it into place, engaging anti-tip bracket.
4. Drill pilot holes through positioning flange. (Use 5/64" drill.) Then install three 1/2" screws at front of bottom duct.

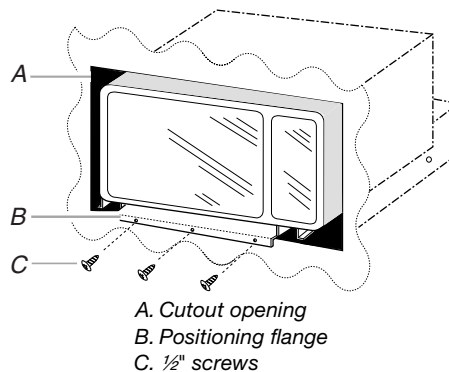

A. Cutout opening
 B. Positioning flange
 C. 1/2" screws