

This Owner's Manual is provided and hosted by [Appliance Factory Parts](http://www.ApplianceFactoryParts.com).

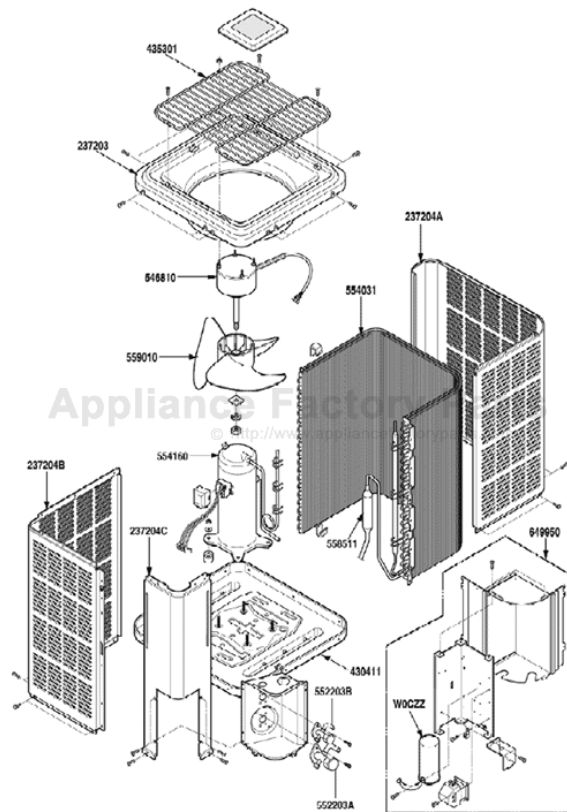

# Texas Furnaces 2AC12030-2 Owner's Manual

[Shop genuine replacement parts for Texas Furnaces  
2AC12030-2](#)



[Find Your Texas Furnaces Air Conditioner Parts - Select From 7 Models](#)

----- Manual continues below -----



website <http://www.LG.ca>

LG

LG

# Installation Instructions & Use and care *MANUAL*

**LG Central Air Conditioning  
Remote Condensing Unit**

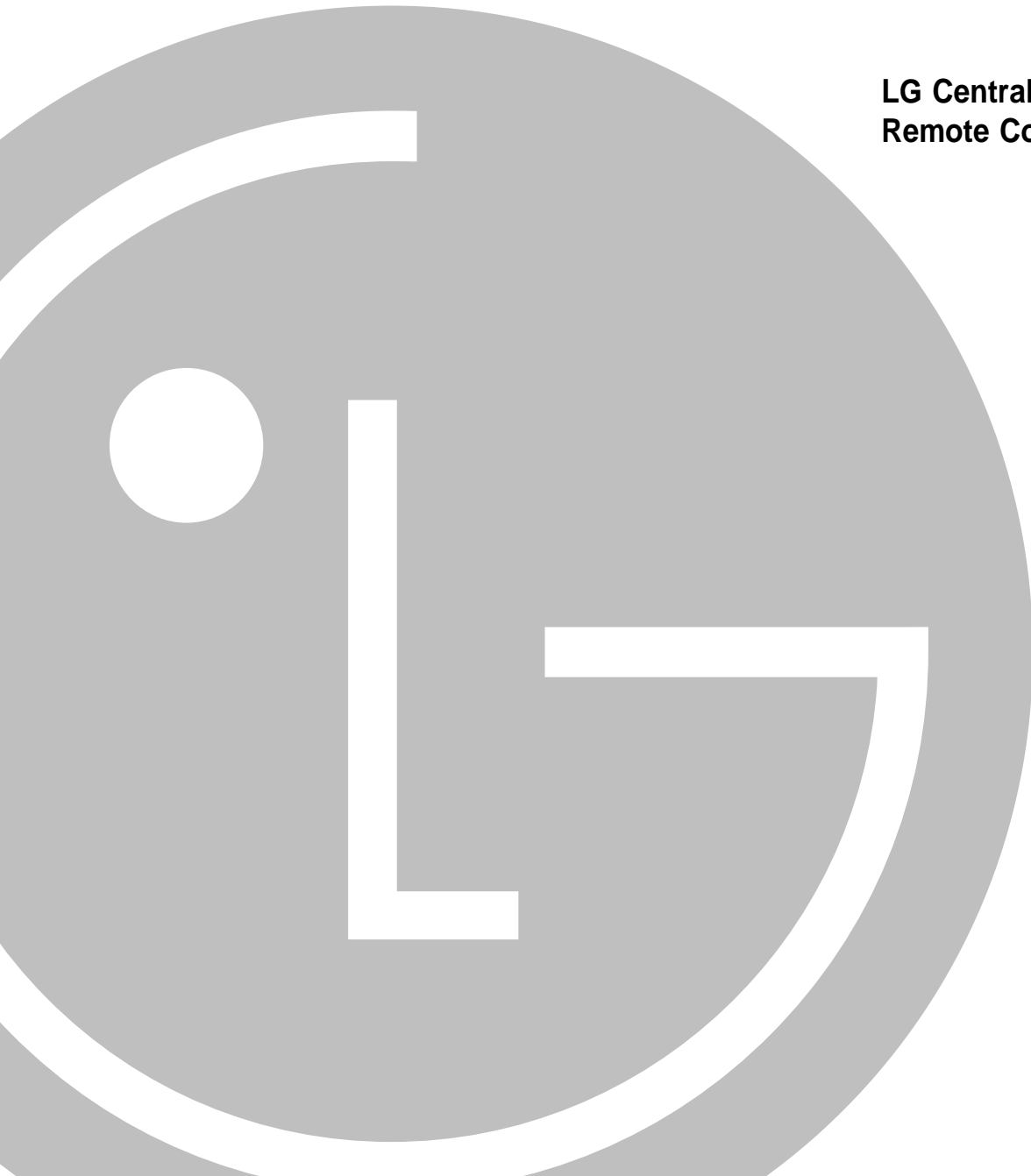

# Installation Instructions

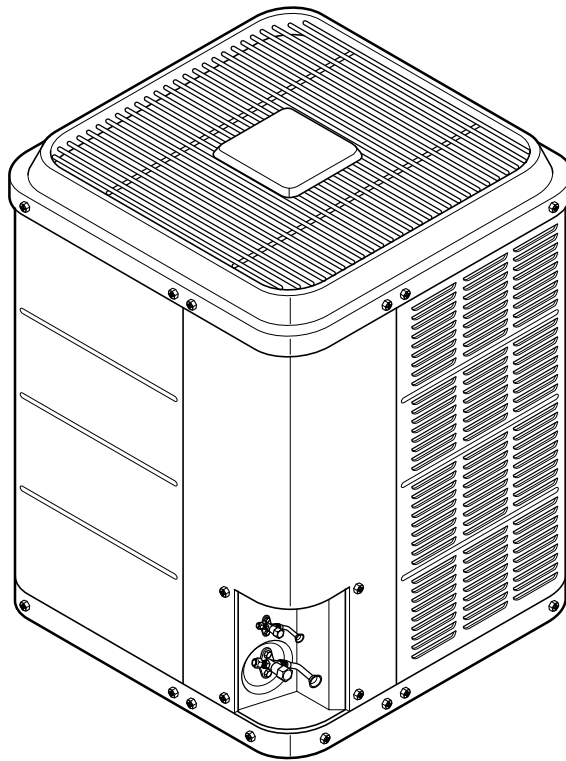

Attention Installer:  
System installer's guide  
Check list (Page 11.) shall be  
completed as per instructions

These Instructions Should be carefully read and kept with the production for future reference

---

## CONTENTS

### **INSTALLATION**

<b>SAFETY</b> .....	2
<b>SHIPPING INSPECTION</b> .....	3
<b>UNIT DIMENSIONS</b> .....	3
<b>MINIMUM CLEARANCES</b> .....	3
<b>INSTALLATION LOCATION</b> .....	3
<b>REMOVING EXISTING CONDENSING UNIT</b> .....	3
<b>REFRIGERANT HANDLING</b> .....	4
<b>LINE SET INSTALLATION</b> .....	4
<b>INSTALLATION</b> .....	5
<b>METERING DEVICES</b> .....	5
<b>BRAZING CONNECTIONS</b> .....	5
<b>LEAK TESTING</b> .....	5
<b>EVACUATION</b> .....	6
<b>LINE SET REFRIGERANT(CHARGE) ADJUSTMENT AND RELEASE OF CHARGE</b> .....	7
<b>ELECTRICAL</b> .....	7
<b>CONDENSING UNIT WIRING DIAGRAM</b> .....	8
<b>SYSTEM START-UP / FINAL CHARGE ADJUSTMENT</b> .....	8
<b>FINAL CHARGE ADJUSTMENT</b> .....	9
<b>FOR TXV</b> .....	9
<b>FINAL CHECKS</b> .....	10
<b>USE AND CARE</b>	
<b>CARE AND MAINTENANCE</b> .....	10
<b>SYSTEM INSTALLER'S GUIDE - CHECK LIST</b> .....	11
<b>USE AND CARE MANUAL</b> .....	14
<b>LIMITED WARRANTY</b> .....	17

### SAFETY

- Understand the following safety terms:
  - o **Danger!** - Identifies hazards that will result in personal injury or death.
  - o **Warning!** - Identifies hazards that could result in personal injury or death.
  - o **Caution!** - Identifies unsafe practices that will result in minor personal injury, property damage, or product damage.
- Read all installation instructions thoroughly prior to installing product.
- **Warning! Always use disconnect switch to disconnect power to condensing unit prior to opening control box. Never locate disconnect switch on unit.**
- **Caution! Follow all local plumbing, electrical, and any other codes that may apply.**
- Wear safety glasses and gloves.
- EPA requires all refrigerant to be recovered. Do not blow charge into atmosphere.
- **Danger!** Do not sniff or inhale refrigerant. Personal injury and death is possible.

## SHIPPING INSPECTION

This product was carefully inspected at the factory and released to the transportation company with no known damage. Inspect carton for damage to help locate potential areas of damage. Remove carton and inspect entire unit for damage. If damage is found, report it immediately to the carrier.

## UNIT DIMENSIONS

Physical Data, 12 SEER Models

**Table 1**

	1.5 Ton	2.0 Ton	2.5 Ton	3.0 Ton	3.5 Ton	4.0 Ton	5.0 Ton
A	24 <sup>21/32</sup>	24 <sup>21/32</sup>	24 <sup>21/32</sup>	24 <sup>21/32</sup>	28	28	-
B	22 <sup>11/16</sup>	22 <sup>11/16</sup>	22 <sup>11/16</sup>	22 <sup>11/16</sup>	27	27	-
C	27 <sup>11/16</sup>	27 <sup>11/16</sup>	27 <sup>11/16</sup>	27 <sup>11/16</sup>	32 <sup>5/8</sup>	32 <sup>5/8</sup>	-

## MINIMUM CLEARANCES (SEE FIGURE 1)

- 30" clearance to service panel
- 6" clearance to one side of the unit.
- 12" clearance to two other sides of unit.
- 24" Clearance between two condensing units.
- 60" clearance above unit.

## INSTALLATION LOCATION

- Away from windows
- Do not install under gas appliance vent
- At least 36" away from clothes dryer vent
- On a solid, level pad
- Isolated from the building structure (Avoid vibration transmission)

## REMOVING EXISTING CONDENSING UNIT

- **Warning! Electrical shock can cause severe injury or death. Use disconnect switch to disconnect power to unit.**
- **Warning! Recover all refrigerant from prior unit to avoid personal injury or death.**

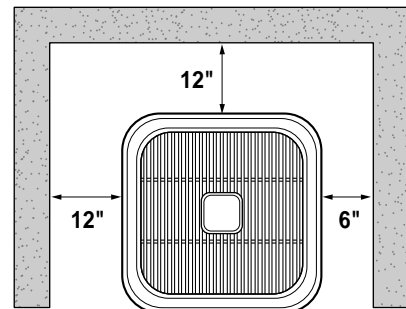
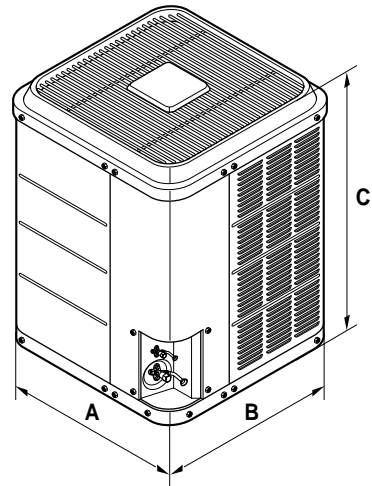

TOP VIEW

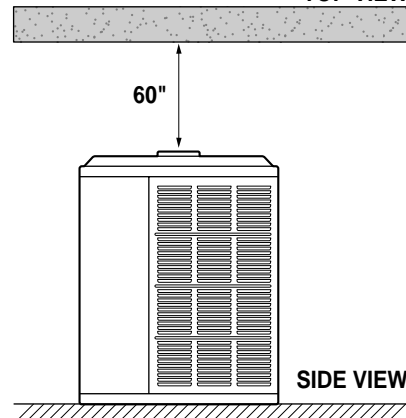

SIDE VIEW

Fig. 1

## REFRIGERANT HANDLING

- **Warning! Do not sniff or inhale refrigerant. Personal injury or death may occur.**
- **Warning! Avoid contact with liquid refrigerant. Wear gloves and safety glasses to avoid frostbite and blindness.**
- **Warning! Never apply flame to refrigerant cylinder. Possible explosion resulting in personal injury or death is possible.**
- **Warning! Never fill a cylinder more than 80% full of liquid refrigerant.**
- Always recover refrigerant. EPA requires all refrigerant to be recovered.
- **Warning! Always use EPA certified testing equipment and certified refrigerant tanks. Make sure tanks have passed a hydrostatic test performed in last 5 years.**

## LINE SET INSTALLATION

- Verify proper diameter sizes for liquid line and vapor lines.
- Long line sets may require larger diameter vapor line (See Table 2).

Table 2

COND UNIT (TONS)	REFRIGERANT LINE LENGTH (ft)					
	0 - 24		25 - 49		50 - 85	
	Line Diameter (in. OD)					
	Suct	Liq	Suct	Liq	Suct	Liq
1.5	3/4"	3/8"	3/4"	3/8"	3/4"	3/8"
2	3/4"	3/8"	3/4"	3/8"	3/4"	3/8"
2.5	3/4"	3/8"	7/8"	3/8"	7/8"	1/2"
3	3/4"	3/8"	7/8"	3/8"	1-1/8"	1/2"
3.5	7/8"	3/8"	1-1/8"	3/8"	1-1/8"	1/2"
4	7/8"	3/8"	1-1/8"	3/8"	1-1/8"	1/2"
5	7/8"	3/8"	1-1/8"	3/8"	1-1/8"	1/2"

- The maximum line set length is listed in Table 3. Refer to Figure 2 for dimension measurement.
- The factory oil charge is sufficient for Max. length in table 3.
- **Caution! Same line sets may require longer than maximum. length listed in table 3, please contact your wholesaler or/and distributor before installation.**
- Indoor unit may be a maximum of 50 feet above outdoor unit (See Figure 2).
- For every 35 feet that the outdoor unit is above the indoor unit, an oil trap must be installed (See Figure 3).
- Vapor line must be insulated (See Figure 4).
- Insulate liquid line if ambient temperatures exceed 120°F
- Liquid and vapor lines must not make metal-to-metal contact.
- Avoid unnecessary turns.

Table 3

COND UNIT (TONS)	LENGTH "X" IN FT MAX.
1.5	75
2	85
2.5	85
3	85
3.5	85
4	85
5	85

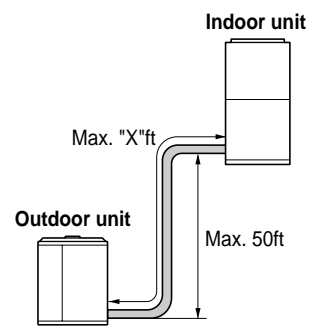

Fig. 2

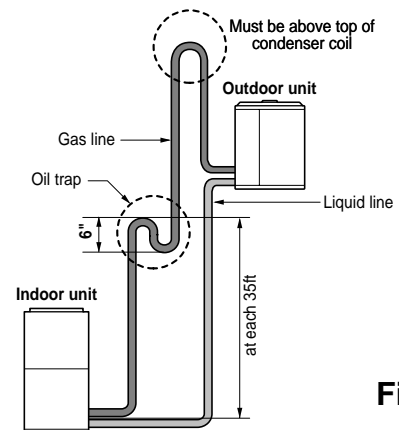

Fig. 3

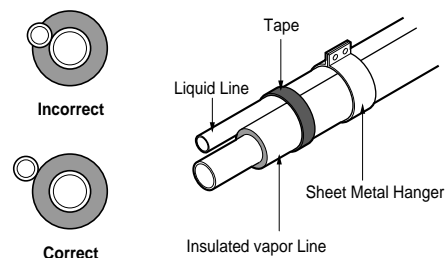

Fig. 4

- Do not make direct contact with ductwork, floor joists, wall studs, walls, and plumbing.
- Leave slack between building and unit to avoid vibration transmission.
- Seal wall penetration with RTV or other suitable caulk.
- Do not strap line set to joists with wire or strapping in direct contact.
- **Liquid line filter drier is factory-installed in unit.**

## INSTALLATION

- Set unit on pad with electrical control box close to house.
- Bolt to pad if local codes require.
- If installed on rooftop, unit must be securely mounted with vibration isolators to prevent vibration transmission.

## METERING DEVICES

### **For piston (Orifice):**

- Indoor piston must be changed to required piston size provided with condensing unit. Piston size is listed on rating plate.
- Piston is located between liquid line set and indoor coil distributor.

### **For TXV:**

#### **• Caution! Remove piston located between liquid line set and indoor coil distributor.**

- Screw TXV into distributor assembly.
- Connect pressure equalizer tube w/ flare nut to indoor coil pressure port.
- **Caution! Always make sure the suction line is cleaned before clamping the bulb in place.**
- On lines that are 3/4" O.D. or smaller, the bulb may be installed on top of the line or side mounted (preferably at the 10 or 2 o'clock position) (See Figure 5).
- On lines that are 7/8" O.D. or larger, the remote bulb should be installed at 45° or at approximately the 4 or 8 o'clock position (See Figure 5).
- Insulate temperature bulb with foam insulation.

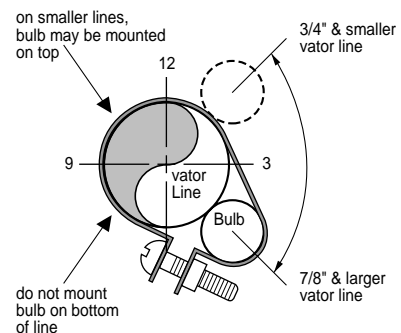

**Fig. 5**

## BRAZING CONNECTIONS

1. Ends of the refrigerant lines must be cut square, deburred, and cleaned.
2. Sweep refrigerant lines with Nitrogen or other inert gas.
3. **Caution! Wrap service valve with wet rag to avoid overheating (It is recommended, to removed the valve core prior to brazing).**
4. Use a brazing alloy rod with minimum 2% silver.
5. After brazing, quench joint with water or wet rag and re-install vale core.
6. Re-install valve core, if removed.

## **LEAK TESTING**

1. Close hand valves on gauge set.
2. Attach gauge hoses to service valve ports.
3. Keep service valves closed.
4. Connect nitrogen cylinder to center port on gauge set.
5. Open nitrogen cylinder valve slightly.
6. Open high pressure valve on gauge set.
7. Pressurize to 150 psig.
8. Close valve on nitrogen cylinder.
9. Apply soap solution on all connections and joints.
10. Mark bubble locations for repair.
11. Using gauge set, release nitrogen from system.
12. Repair leaks, if any.
13. Repeat leak test until there are no leaks.

## **EVACUATION (See Figure 6)**

1. Close valves on gauge set.
2. Connect gauge hoses to service valve ports. (Service valves on unit remain closed)
3. Connect vacuum pump to gauge set.
4. Start the vacuum pump.
5. Open the high and low pressure ports on the gauge set.
6. Begin evacuation.
7. Vacuum pressure must pull down below 500 microns in 2 minutes or less.
  - If after 2 minutes the vacuum pressure does not drop below 500 microns, go back to leak test.
8. Evacuate for thirty minutes.
9. Shut off valve to vacuum pump.
10. Wait ten minutes and read pressure.
  - If pressure is below 1000 microns, system is ready.
  - If pressure is between 1000 and 2000 microns, continue evacuation for an additional 30 minutes.
  - If pressure is above 2000 microns, there is a leak in the system. Go back to leak test.
11. Shut off the pump.
12. Close valves on gauge set.

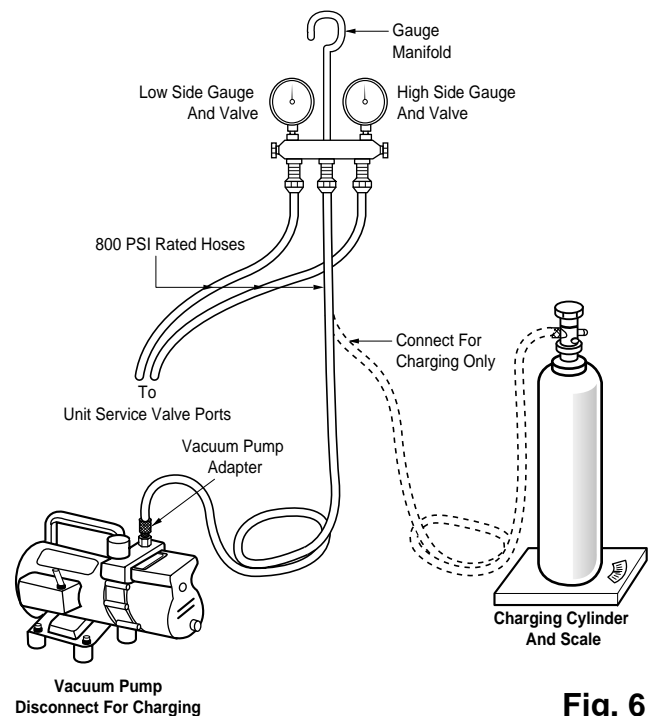

**Fig. 6**



---

## **LINE SET REFRIGERANT(CHARGE) ADJUSTMENT AND RELEASE OF CHARGE**

Condensing units are factory-charged with enough refrigerant for typical evaporator coil sizes and 25 feet of line set tubing. Refer to Table 4 for proper refrigerant adjustment.

**Table 4**

Liquid Line OD (in)	Adjustment (oz/ft)
1/4"	0.22
5/16"	0.39
3/8"	0.58
1/2"	1.14

If line set is different from 25 feet, adjust charge as follows:

Example 1: 40 feet line set, 3/8" Liquid Line, 3/4", Vapor Line  
40 ft - 25 ft = 15 ft x .58 oz/ft = 9 ounces of additional charge

Example 2: 15 feet line set, 3/8" Liquid Line, 7/8" Vapor Line  
15 ft - 25 ft = -10 ft x .58 oz/ft = 6 ounces of charge to takeout

If additional charge is needed, add charge to line set prior to releasing charge.  
If charge needs to be reduced, recover charge during final charge adjustment.

### **Factory Charge Release**

With gauge set valves closed, open both service valves.

## **ELECTRICAL**

**Warning! To avoid personal injury or death, disconnect power to unit prior to electrical wire connections.**

1. Open disconnect switch.
2. Trip circuit breaker to indoor air handler or gas furnace.
3. Select proper wire size per National Electric Code.
4. Connect power wires and ground wire as shown in Figure 7

**Warning! Electrical ground wire must be connected to the unit's metal cabinet to prevent a ground fault and avoid personal injury or death. Failure to properly ground unit can result in personal injury, death, fire, and property damage.**

5. Use 18AWG wire for 24 volt control connections..
6. Connect 24 volt wires from indoor unit as shown in Figure 7.
7. Close control box to unit.
8. Reset circuit breaker to indoor air handler or gas furnace.
9. Close disconnect switch for outdoor unit.

## CONDENSING UNIT WIRING DIAGRAM

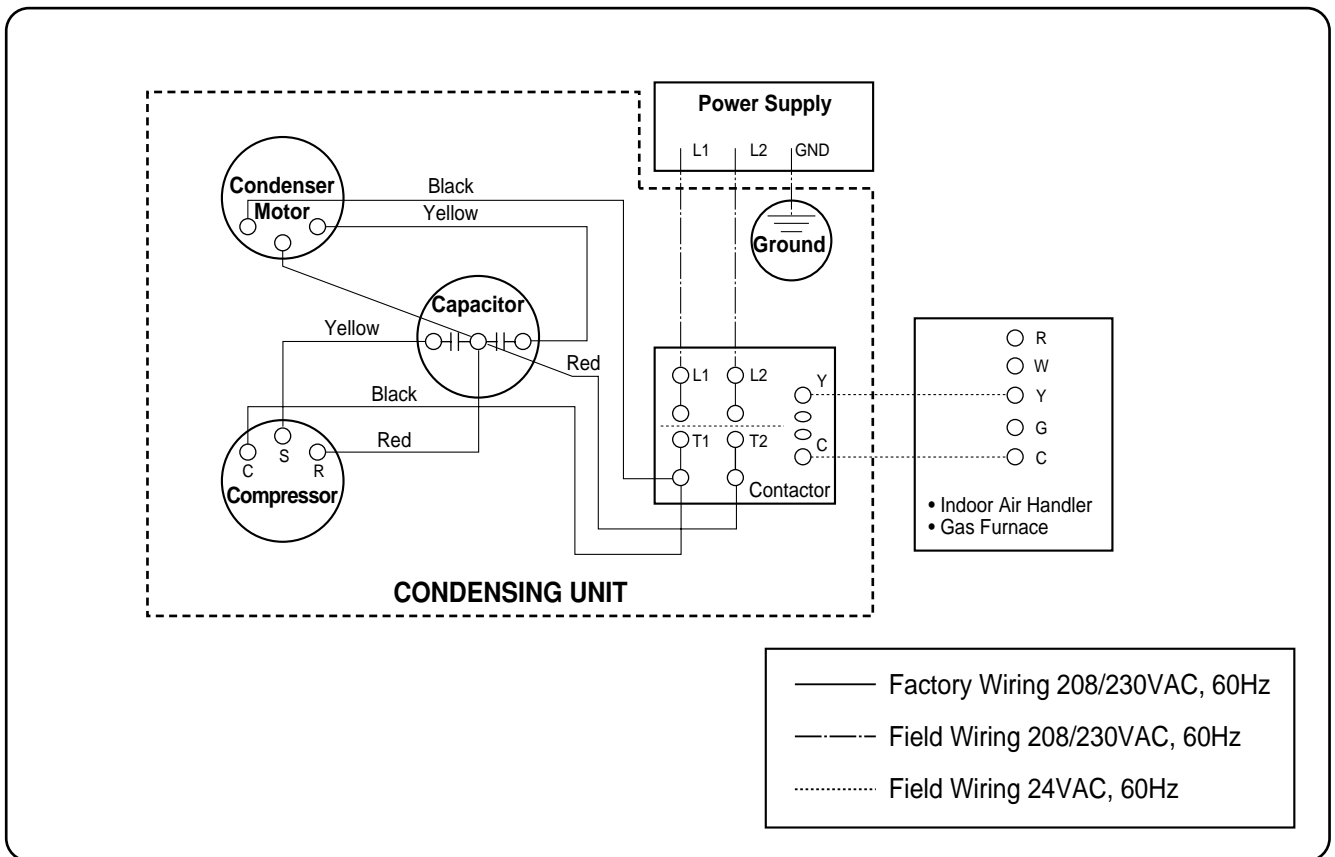

**Fig. 7**

## SYSTEM START-UP / FINAL CHARGE ADJUSTMENT

- Set temperature setting on thermostat at least 3 degrees below the current indoor temperature in the house.
- Allow the unit to run for 15 minutes.
- Attach thermocouples to both the liquid and vapor lines within 2 feet of service valves.
- Place third thermocouple to sense outdoor air temperature near unit.
- Record low pressure and high pressure on the gauge set.
- Record thermocouple temperatures of liquid line, vapor line, and outdoor temperature.
- Record indoor air temperature near return duct.
- Refer to temperature-pressure chart for proper refrigerant.
- Look up low pressure reading on Table 5. Record saturated vapor temperature corresponding to the suction pressure.
- Calculate actual superheat as follows:  

$$SH = T_{\text{vapor line}} - T_{\text{sat. vapor}}$$
- Look up high pressure reading on Table 6. Record saturated liquid temperature corresponding to the liquid line pressure.
- Calculate actual subcooling as follows:  

$$SC = T_{\text{liquid line}} - T_{\text{sat liquid}}$$

**Table 5**

<b>Saturated Suction Temperature (R-22)</b>	
Suction Pressure (PSIG)	Saturated Suction Temperature (°F)
60.1	34
62.8	36
65.6	38
68.5	40
71.4	42
74.5	44
77.6	46
80.7	48
84	50
87.3	52
90.8	54
94.3	56

**Table 6**

<b>Saturated Suction Temperature (R-22)</b>	
Suction Pressure (PSIG)	Saturated Suction Temperature (°F)
195.9	102
210.7	105
220	108
229.5	111
239.3	114
249.4	117
259.8	120
270.5	123
281.6	126
289.1	128
300.6	131
308.5	134

**FINAL CHARGE ADJUSTMENT**

**Caution! Do not overcharge unit with refrigerant. Overcharged unit may result in compressor damage or personal injury.**

**For Piston (Orifice) Metering:**

**Look up proper superheat for given outdoor air temperature and return air temperature (Table 7). If actual superheat is above the proper superheat amount, more refrigerant must be added. If actual superheat is below the proper superheat amount, remove small quantity of refrigerant.**

**Table 7**

<b>System Superheat</b>					
Outdoor Temperature (°F)	Return Air Temperature (°F, DB)				
	65	70	75	80	85
105	-	-	-	2	4
100	-	-	-	5	8
95	-	-	4	10	13
90	-	-	7	14	18
85	-	-	10	17	22
80	-	6	14	21	26
75	-	10	18	25	29
70	7	14	22	29	32
65	13	19	26	32	35
60	17	25	30	34	37

**For TXV:**

**Look up proper subcooling level for TXV listed on rating plate. If actual subcooling is below the proper subcooling by more than 2°F, refrigerant must be added. If actual subcooling is greater than the proper subcooling by more than 2°F, remove small quantity of refrigerant.**

---

## **FINAL CHECKS**

Verify that all wiring is secure and routed properly.

Check that all tubing is sound.

**Caution! Compressor dome may be hot! Don't touch compressor dome.**

Securely fasten all panels and covers.

Leave Use and Care Manual with homeowner.

Discuss operation and routine maintenance with homeowner.

## **CARE AND MAINTENANCE**

**Warning! Always use disconnect switch to disconnect power to unit prior to opening electrical control box to avoid electrical shock. Electrical shock can cause personal injury or death.**

**Warning! Always recover refrigerant and relieve pressures before system repair to avoid personal injury or death.**

---

# SYSTEM INSTALLER'S GUIDE - CHECK LIST

## CHECKOUT PROCEDURE (After completion, review and leave with home owner or as directed)

Date of Installation \_\_\_\_\_

Model Number \_\_\_\_\_ Serial Number \_\_\_\_\_

Installing Contractor Name \_\_\_\_\_

Installing Contractor Phone Number \_\_\_\_\_

After installation has been completed, it is required that the entire system be checked against the following list:

1. Refrigerant Line, Leak checked ( )
2. Vapor Lines and Fittings properly insulated? ( )
3. Have passages through masonry been sealed? If mortar is used, prevent mortar from coming in direct contact with copper tubing ( )
4. Indoor coil drains freely. Pour water into drain pan. ( )
5. Supply registers and return grilles are open and unobstructed. ( )
6. Return air filter installed. ( )
7. Thermostat thermometer is accurate, and thermostat is level. ( )
8. Is correct speed tap being used? (Indoor blower motor) ( )
9. Does the condenser fan blade rotate freely, and is it tight on the shaft? ( )
10. Are both indoor and outdoor sections level? ( )
11. Are the units properly supported? ( )
12. Is outdoor section properly located on concrete base or equivalent? ( )

- 
13. Is the refrigerant tubing properly supported by isolation hangers? ( )
  14. Has the system been properly evacuated? ( )
  15. Is the outdoor unit protected by the correct size time delay type fuses or breakers in the indoor electrical panel? ( )
  16. Are the power supply wires to units the correct size? ( )
  17. Are all electrical connections tight? ( )
  18. Does the compressor sound normal? ( )
  19. Check the amperage on the indoor blower motor. Is it within the limits shown on the nameplate of the motor? ( )
  20. Are all access panels installed and secured? ( )
  21. Do controls function properly? ( )
  22. Check the voltage with unit running. Does it check within the tolerance of 207 to 253V for 230V, or 198 to 228V? If using 208V power indoors, have you modified the transformer wiring as necessary? ( )
  23. Has the air flow across the indoor coil been checked and adjusted? ( )
  24. Has the system operated at least 30 minutes before leaving the job? ( )
  25. Does the owner understand the operation of the unit and the thermostat? ( )
  26. Does the owner know where the filters are located? ( )
  27. Does the owner know when and how the filter(s) should be cleaned or changed? ( )
  28. Have the registration cards been filled out and mailed? ( )
  29. Does the owner know whom to call for service? ( )
  30. Has the User's Guide been filled out and left with the owner? ( )

---

## SYSTEM OPERATIONAL CHECK

**IMPORTANT:** To prevent compressor damage which may result from the presence of LIQUID refrigerant in the crankcase, these procedures should be followed at initial Start-Up and at anytime the power has been off for 12 hours or more if the compressor uses a crankcase heater.

1. Place the thermostat's system switch in the "OFF" position and apply power by closing system disconnect switch. Allow the system to remain off, but with power supplied for a minimum of one hour if compressor uses a crankcase heater.

**OPERATING PRESSURES:** After the unit has operated in the cooling mode for 15 minutes, install pressure gauges on the gage ports of the liquid and Vapor valves. Check the Vapor and liquid line pressures and compare them to the normal operating pressures provided in the unit's Service Manual.

**NOTE: TO CHARGE THE SYSTEM ACCURATELY, USE SUPERHEAT OR SUBCOOLING METHOD DEPENDING ON THE FLOW CONTROL USED IN THE SYSTEM.**

2. Except as required for safety while servicing: **DO NOT OPEN SYSTEM DISCONNECT SWITCH.**

3. Measure and record the following:

■ Line voltage @ contactor during start-up	:	_____	VAC
■ Compressor amperage	:	_____	Amps
■ Condenser Fan Amperage	:	_____	Amps
■ Vapor(Suction) Pressure	:	_____	PSIG
■ Liquid Line Pressure	:	_____	PSIG
■ Superheat	:	_____	*F
■ Sub-cooling	:	_____	*F
■ Outdoor temperature	:	_____	*F
■ Indoor temperature	:	_____	*F

## SUPPLEMENTARY HEATERS CHECKOUT PROCEDURES, IF USED

DOES HEATER REQUIRE A SEPARATE CIRCUIT \_\_\_\_\_?

4. Ensure that the disconnect switch is "OFF", and the safety label (if any) is attached ( )
5. Check field wiring for sound connections and grounding according to codes ( )
6. Check fuses or breakers for proper size per nameplate specifications ( )
7. Check control box panel – in place and secured ( )

**NOTE: OPERATION OF HEATERS MUST BE CHECKED DURING THE OPERATION CHECK OF THE TOTAL SYSTEM**

# Use and Care Manual

Thank you for your purchase of this air conditioning unit. This air conditioning unit has been carefully designed, built, and tested to ensure many years of energy-efficient comfort.

## SAFETY

- Understand the following safety terms:
  - **Danger!** - Identifies hazards that will result in personal injury or death.
  - **Warning!** - Identifies hazards that could result in personal injury or death.
  - **Caution!** - Identifies unsafe practices that will result in minor personal injury, property damage, or product damage.
- Read all installation instructions thoroughly prior to installing product.
- Follow all instructions carefully.
- **Warning! Improper maintenance, adjustment, installation, or use can cause electrical shock or other conditions that may result in personal injury, death, or property damage.**
- Refer to a qualified installer/dealer for service work or assistance. **Warning! Do not to attempt to repair the air conditioner yourself.**

## THERMOSTAT OPERATION

The air conditioning unit is controlled by an indoor thermostat. If you have recently moved into your home, take some time to familiarize yourself with operation of the thermostat. There are various designs of thermostats (mechanical, electronic, programmable, etc.), but they all work basically the same.

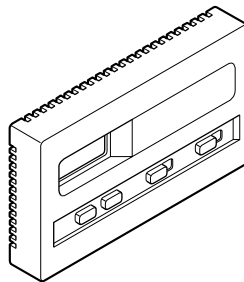

Typical Thermostat

Thermostats have three to four modes of operation. They are:

**OFF** - In this mode the house will not be heated or cooled, regardless of inside temperature.

**HEAT** - In this mode the house will be heated if the desired temperature is higher than the actual inside temperature.



**COOL** - In this mode the house will be cooled if the desired temperature is below the actual inside temperature.

**AUTO** - In this mode the house will be heated or cooled when the inside temperature of the house falls outside a specified range.

Thermostats also have a fan control. This controls the operation of the indoor fan that circulates the air inside the house. The fan control has two modes:

**AUTO** - In this mode the fan will only operate when the house is being heated or cooled.

**ON** - In this mode the fan will run continuously regardless of whether the house is being heated or cooled.

## **ROUTINE MAINTENANCE**

With routine maintenance, your new air conditioner will operate efficiently for many years. The following are maintenance items you can do to keep the unit running at peak efficiency:

### **OUTDOOR COIL**

There are several things you can do to keep your outdoor coil clean and performing at top efficiency:

- Keep yard debris (grass clippings, dirt, leaves, etc.) from entering the condenser coil.
- Avoid planting bushes too close to unit.
- Use a condenser cap or cover during winter (Make sure to remove prior to cooling season). If using cover, make sure cover is short enough to expose unit at least 4" from the ground)
- Verify that clothes dryer vent is not blowing lint at outdoor unit.  
In some cases, the outdoor coil may need to be cleaned. This is a job that must be performed by a qualified dealer.

### **AIR FILTER**

The air filter collects dust and other particles to keep the air inside your house clean. In time, however, the filter will begin to clog, restricting the airflow to the house and causing the indoor blower motor to work harder and less efficiently. Replace disposable filters every six weeks.

Clean permanent filters by washing them with recommended detergent solution per the filter manufacturer's instructions every six weeks.

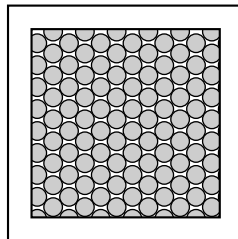

Disposable Filter

To change the filter, you must do the following:

- Turn thermostat mode switch to "OFF"
- Turn thermostat fan switch to "AUTO"
- **Warning! If filter is located inside the furnace or air handler, you must disconnect power to the indoor and outdoor units. This may be done by switching the disconnect switches to "OFF" or tripping your circuit breakers in the electrical panel. Failure to disconnect power may result in**

---

**electrical shock. Electrical shock may cause personal injury or death.**

- Open door/panel to access filter. **Caution! Although sharp edges have been minimized in the unit, be careful when reaching into unit or touching/handling parts.**
- Change/clean filter
- Close door/replace panel
- If filter is located inside furnace or air handler, reconnect power to indoor and outdoor units.
- Adjust thermostat to original setting

### **INDOOR COIL**

By changing disposable air filter or cleaning permanent air filter, the indoor coil should stay fairly clean.

If coil cleaning is needed, please call your local dealer for service. The local dealer has the appropriate detergents needed to properly clean the coil.

### **TROUBLESHOOTING**

If your air conditioner is not operating or operating poorly, check the following:

- Check air filter and replace if clogged.
- Make sure thermostat is adjusted/programmed correctly.
- Make sure indoor and outdoor disconnect switches are turned "ON."
- Check circuit breakers box or fuse box to see if breakers are tripped or fuses blown
- If none of these fix the problem, contact your local dealer, providing them with model number and serial number

## **LIMITED WARRANTY**

Should your product prove to be defective in materials or workmanship under normal use during the warranty period listed below, LG Electronics will, at its option, repair or replace the defective part(s). Replacement part(s) will meet intended fit and function of the original part(s).

Replacement parts are warranted for the unexpired portion of the original warranty.

The warranty period begins on the original date of purchase. If the original date of purchase cannot be verified, the warranty will begin 60 days from the date of manufacture.

The warranty is valid only to the original purchaser of the product, during the warranty period, as long as it is in Canada.

### **Central Air Conditioner Warranty Period**

<u>Components</u>	<u>Parts</u>
All Parts	5 Years
Compressor	10Years

No other warranty is applicable to this product. THE DURATION OF ANY IMPLIED WARRANTIES, INCLUDING THE IMPLIED WARRANTY OF MERCHANTABILITY, IS NOT LIMITED TO THE DURATION OF THE EXPRESS PRODUCT, INCONVENIENCE, LOSS OR ANY OTHER DAMAGES, DIRECT OR CONSEQUENTIAL, ARISING OUT OF THE USE OF OR INABILITY TO USE, THIS PRODUCT OR FOR ANY BREACH OF ANY EXPRESS OR IMPLIED WARRANTY, INCLUDING THE IMPLIED WARRANTY OF MERCHANTABILITY OR FITNESS FOR A PARTICULAR PURPOSE, APPLICABLE TO THIS PRODUCT.

Some Provinces or Territories do not allow for the exclusion or limitation of incidental or consequential damages or limitations on how long an implied warranty lasts; so these limitations or exclusions may not apply to you. This warranty gives you, the original purchaser specific legal rights and you may also have other rights, which vary from province to province or territory to territory.

#### **THIS WARRANTY DOES NOT APPLY TO:**

1. Service trips to your home for delivery or pickup, install, instruct or replace house fuses, or connect house wiring or plumbing, or correction of unauthorized repairs.
2. Failure of product to perform during power failures and interruptions or inadequate electrical service.
3. Damage caused by transportation or handling.
4. Damage to the product caused by accident, pest, lightning, winds, fire, floods, or acts of God.
5. Damages caused by leaky or broken water pipes, frozen water pipes, restricted drain lines, or inadequate or interrupted water supply.
6. Damages cause by inadequate supply of air.
7. Damages resulting from running the product in a corrosive atmosphere.
8. Repairs when your LG product is used in other than normal, single-family household use or contrary to the instructions outlined in the product owner's manual.
9. Damage resulting from accident, misuse, abuse, or improper installation, repair, or maintenance. Improper repair includes use of parts not approved or specified by LG.
10. Normal maintenance as described in the installation instructions and use and care manual, such as replacing filters, cleaning of coils, etc.
11. Use of accessories or components that are not compatible with this product.
12. Products with altered or removed serial numbers.
13. Changes in the appearance of the product that do not affect product performance.
14. Increases in utility costs and additional utility expenses.

If the product is installed outside the normal service area, any cost of transportation involved in the repair of the product, or replacement of a defective part, shall be borne by you (the owner).