

APPLY SERIAL NUMBER LABEL FROM CARTON



Serial No. XXXXXX000000
MODEL NO.



GOURMET GRILLS

Award Winning Products

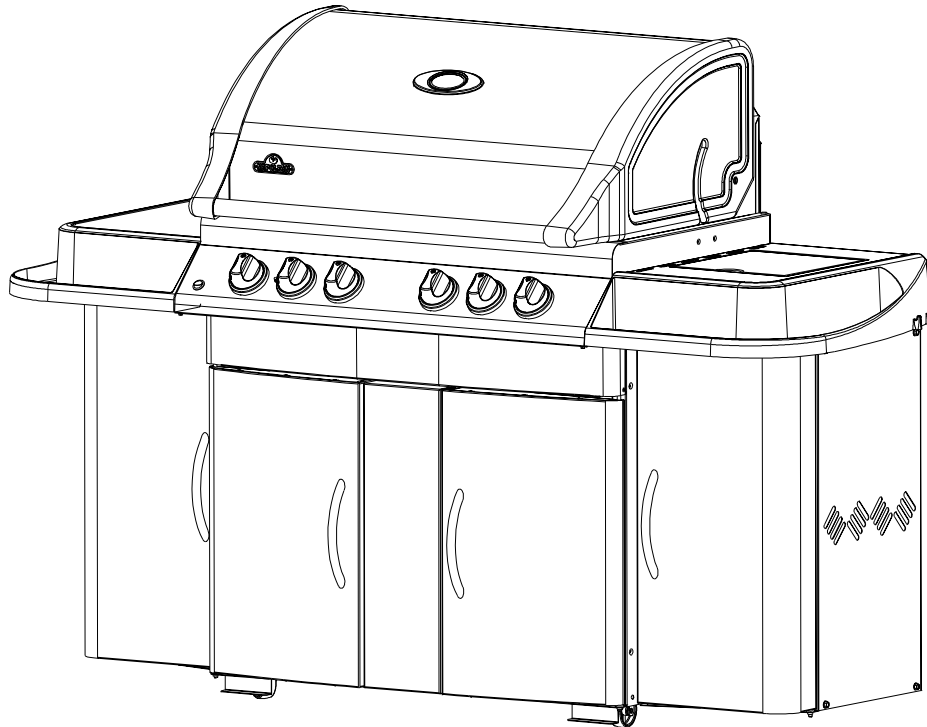

ASSEMBLY AND OPERATING INSTRUCTIONS

MIRAGE 605

OUTDOOR STAINLESS STEEL GAS GRILL

**NOTICE TO INSTALLER:
LEAVE THESE INSTRUCTIONS
WITH THE GRILL OWNER FOR
FUTURE REFERENCE**

⚠ DANGER

IF YOU SMELL GAS:

- Shut off gas to the appliance.
- Extinguish any open flame.
- Open lid.
- If odor continues, keep away from the appliance and immediately call your gas supplier or your fire department

DO NOT TRY TO LIGHT THIS APPLIANCE WITHOUT READING LIGHTING INSTRUCTIONS SECTION OF THIS MANUAL



NAPOLEON APPLIANCE CORPORATION,
214 BAYVIEW DR., BARRIE, ONTARIO, CANADA L4N 4Y8 PHONE: (705)726-4278
FAX: (705)725-2564 EMAIL: care@nac.on.ca WEB SITE: www.napoleongrills.com

N415-0157 JAN28/08

THANK YOU FOR CHOOSING NAPOLEON

NAPOLEON products are designed with superior components and materials, and are assembled by trained craftsmen who take great pride in their work. The burner and valve assembly are leak tested and test-fired at a quality test station. This grill has been thoroughly inspected by a qualified technician before packaging and shipping to ensure that you, the customer, receive the quality product you expect from NAPOLEON.

We at Napoleon are dedicated to you, "our valued customer". It is our goal to provide you with the necessary tools to make this an unforgettable grilling experience. This manual is provided to assist you in assuring your new grill is assembled, installed, maintained and cared for properly. It is important to read and understand this entire manual before operating your new grill to ensure you fully understand all safety precautions and features your grill has to offer. By carefully following the instructions inside this manual you will enjoy years of trouble free grilling. For whatever reason if we fail to meet your expectations please call our customer service department at 1-866-820-8686 between 9 AM and 5 PM (eastern standard time) or visit our website.



NAPOLEON GAS GRILL PRESIDENT'S LIMITED LIFETIME WARRANTY

NAPOLEON warrants the following materials and workmanship in your new NAPOLEON gas grill against defects for as long as you own the gas grill. This covers: aluminum castings (excluding paint), LUXIDIO® trays, stainless steel burners, stainless steel lid inserts, and lid handles. Subject to the following conditions. During the first five years NAPOLEON will provide replacement parts at our option free of charge. From the sixth year to lifetime NAPOLEON will provide replacement parts at 50% of the current retail price.

Components such as stainless steel sear plates, stainless steel cooking grids, valves with ignition system, temperature gauges, knobs, ceramic infrared burners are covered and Napoleon will provide parts free of charge during the first two years of the limited warranty.

Components such as regulators, casters, warming racks, hoses and connectors, I-GLOW™, fasteners and accessories are covered and NAPOLEON will provide parts free of charge during the first year of the limited warranty.

NAPOLEON shall not be liable for any transportation charges, labour costs or export duties.

CONDITIONS AND LIMITATIONS

"NAPOLEON warrants its products against manufacturing defects to the original purchaser only, provided that the purchase was made through an authorized NAPOLEON dealer and is subject to the following conditions and limitations:"

This factory warranty is non-transferable and may not be extended what-so-ever by any of our representatives.

The gas grill must be installed by a licenced, authorized service technician or contractor. Installation must be done in accordance with the installation instructions included with the product and all local and national building and fire codes.

This limited warranty does not cover damages caused by misuse, lack of maintenance, grease fires, hostile environments, accident, alterations, abuse or neglect and parts installed from other manufacturers will nullify this warranty.

This limited warranty further does not cover any scratches, dents, painted finishes, corrosion or discolouring by heat, abrasive and chemical cleaners, nor chipping on porcelain enamel parts, nor any components used in the installation of the gas grill.

Should deterioration of parts occur to the degree of non-performance within the duration of the warranted coverage, a replacement part will be provided.

In the first year only, this warranty extends to the replacement of warranted parts which are defective in material or workmanship provided that the product has been operated in accordance with the operation instructions and under normal conditions.

After the first year, with respect to this President's Limited Lifetime Warranty NAPOLEON may, at its discretion, fully discharge all obligations with respect to this warranty by refunding to the original warranted purchaser the wholesale price of any warranted but defective part(s).

NAPOLEON will not be responsible for the installation, labour or any other costs or expenses related to the re-installation of a warranted part, and such expenses are not covered by this warranty.

Notwithstanding any provision contained in this President's Limited Lifetime Warranty NAPOLEON's responsibility under this warranty is defined as above and it shall not in any event extend to any incidental, consequential, or indirect damages.

This warranty defines the obligation and liability of NAPOLEON with respect to the NAPOLEON gas grill and any other warranties expressed or implied with respect to this product, its components or accessories are excluded.

NAPOLEON neither assumes, nor authorizes any third party to assume, on its behalf, any other liabilities with respect to the sale of this product. NAPOLEON will not be responsible for: over firing, blow outs caused by environmental conditions such as strong winds, or inadequate ventilation.

Any damages to the gas grill due to weather damage, hail, rough handling, damaging chemicals or cleaners will not be the responsibility of NAPOLEON.

The bill of sale or copy will be required together with a serial number and a model number when making any warranty claims from NAPOLEON.

NAPOLEON reserves the right to have its representative inspect any product or part prior to honouring any warranty claim.

NAPOLEON shall not be liable for any transportation charges, labour costs, or export duties.

SAFETY PRECAUTIONS

WARNING

Do not store or use gasoline or other flammable liquids or vapor in the vicinity of this or any other appliance. An L.P. cylinder not connected for use must not be stored in the vicinity of this or any other appliance. Keep area clear and free from combustible materials.

WARNING

Failure to follow these instructions could result in property damage, personal injury or death. Read and follow all warnings and instructions in this manual prior to operating grill.

SAFE OPERATING PRACTICES

WARNING

 **DANGER: READ ALL INSTRUCTIONS CAREFULLY BEFORE OPERATING GRILL. FAILURE TO FOLLOW THESE INSTRUCTIONS EXACTLY COULD RESULT IN A FIRE CAUSING SERIOUS INJURY OR DEATH.**

- Read the entire instruction manual before operating grill.
- Under no circumstance should this gas grill be modified.
- Follow lighting instructions carefully when operating grill.
- Gas must be turned off at the propane cylinder or at the natural gas supply valve when the gas grill is not in use.
- Keep children and pets away from hot grill, DO NOT allow children to climb inside cabinet.
- Do not leave the grill unattended while in use.
- Do not move grill when hot or operating.
- This gas grill must not be installed in or on recreational vehicles and/or boats.
- This gas grill must only be stored outdoors in a well-ventilated area and must not be used inside a building, garage or any enclosed area.
- Maintain proper clearance to combustibles (16" to rear of unit 7" to sides). Additional clearance (24") is recommended near vinyl siding or large panes of glass.
- At all times keep the ventilation openings of the cylinder enclosure free and clear from debris.
- Do not locate unit under combustible construction.
- Do not locate in windy settings. High winds adversely affect the cooking performance of the gas grill.
- When the gas grill is stored indoors, the propane cylinder must be disconnected from the grill and stored outdoors in a well ventilated area, disconnected cylinders must not be stored in a building, garage or other enclosed area.
- Inspect the gas hose before each use. If there is evidence of excessive abrasion or wear, it must be replaced before using the gas grill, with a replacement hose assembly specified by the manufacturer.
- Never store a spare LP gas cylinder under or near this grill.
- Never fill the cylinder beyond 80 % full.
- Do not attempt to use a cylinder which is not equipped with a QCC1 type connection.
- Leak test all connections before first use, even if the grill was purchased fully assembled, annually or whenever any gas component has been replaced.
- Never use natural gas in a unit designed for liquid propane gas.
- Never use lighter fluid in a gas grill.
- Use charcoal briquettes only with a Napoleon charcoal tray designed for this unit.
- Burner controls must be off when turning supply cylinder on.
- Do not light burner with lid closed.
- Do not operate rear burner with main burner operating.
- The lid is to be closed during the preheat period.
- Do not route hose underneath drip pan-proper hose clearance to bottom of unit must be maintained.
- Clean grease tray and sear plates regularly to avoid build-up which may lead to grease fires.
- Ensure sear plates are positioned properly according to sear plate installation instructions.
- Do not use side shelves to store lighter, matches or any other combustibles.
- Keep gas hose away from heated surfaces.
- Keep electrical supply cords away from water or heated surfaces.
- Inspect infrared burner venturi tube for spider webs and other obstructions periodically. Clean the tubes completely if you find any such obstructions.
- The outdoor cooking gas appliance and its individual shutoff valve must be disconnected from the gas supply piping system during any pressure testing of that system at test pressures in excess of 0.5psi (3.5kPa).
- The outdoor cooking gas appliance must be isolated from the gas supply piping system by closing its individual manual shutoff valve during any pressure testing of the gas supply piping system at test pressures equal to or less than 1/2 psi (3.5 kPa).

CYLINDER SPECIFICATIONS/GAS HOOK UP



This gas barbecue is certified under Canadian and American national standards, CAN/CSA-1.6-2005 and ANSI Z21.58 -2005 respectively for outdoor gas grills and should be installed to conform with local codes. In absence of local codes, install to the current CAN/CGA-B149.1 Propane Installation Code in Canada or to the National Fuel Gas Code, NFPA54/ANSI Z223.1 in the United States.

If a rotisserie motor is used, it must be electrically grounded in accordance with local codes or, in absence of local codes, with the current CSA C22.1 Canadian electrical code in Canada or the National Electrical Code, ANSI/NFPA 70 in the United States.

CALIFORNIA PROPOSITION 65: The burning of gas fuel creates by-products, some of which are on the list as substances known by the State of California to cause cancer or reproductive harm. When cooking with gas, always ensure adequate ventilation to the unit, to minimize exposure to such substances.

PROPANE CYLINDER SPECIFICATIONS: A dented or rusty cylinder may be hazardous and should be checked by your propane supplier. Never use a cylinder with a damaged valve. Use only a propane supply cylinder constructed and marked in accordance with the specifications for LP-gas cylinders of the Canadian Transport Commission (CTC) or the US Department of Transportation (DOT). This appliance has been designed for use with a 20lb. (9.1 kg) size propane cylinder only (not supplied).

The propane cylinder must be provided with a shut-off valve terminating in a propane cylinder valve type QCC1, and a safety relief device having direct communication with the vapour space of the cylinder. The cylinder supply system must be arranged for vapour withdrawal and the cylinder shall include a collar to protect the cylinder valve. The cylinder shall incorporate an OPD (overfill protection device).

CYLINDER CONNECTION: Ensure that the gas regulator hose is kink free. Remove the cap or plug from the cylinder fuel valve. Insert the black QCC1 regulator nipple onto the QCC1 fuel valve. Hand tighten clockwise. Do not use tools. Leak test all joints prior to using the barbecue. A leak test must be performed annually, and each time a cylinder is hooked up, or if a part of the gas system is replaced.

PROPANE CYLINDER INSTALLATION:

Check that the cylinder valve is closed by turning the knob clockwise.

Check that the grill's burner knobs are in the off position.

Open cabinet doors.

Place the cylinder into the tank holder in bottom of shelf.

Position the cylinder so that the valve faces toward the front of the unit.

Attach regulator hose.

IMPORTANT: Use only the pressure regulator and hose assembly provided with this barbecue. Replacement pressure regulators and hose assemblies must be specified by the manufacturer. Do not store propane cylinder or spare cylinder on the shelf beneath the barbecue. **The regulator must be attached so that no part of the hose touches the underside of the grill or drippan. A fire will result if these directions are ignored.**

The regulator supplies a pressure of 11 inches water column to the gas grill and has a QCC1 type fitting. Cylinders to be used with this unit must be supplied with a Sherwood #3349 QCC1 cylinder valve. A QCC1 cylinder has a positive seating connection, which will not allow gas flow until a positive seal has been achieved. It is also equipped with an excess flow device. In order to attain full flow to the barbecue, **the valves must be in the off position when the cylinder valve is turned on.**

NATURAL GAS HOOK-UP: This natural gas grill is supplied with a 10ft supply hose (complete with a quick disconnect) designed for natural gas and certified for outdoor use. The gas grill is designed to operate at an inlet pressure of 7 inches water column. Piping and valves upstream of the quick disconnect are not supplied.

The quick disconnect must not be installed in an upward direction and a readily accessible manual shut-off valve must be installed upstream of, and as close to, the quick disconnect as is feasible. The flared end of the hose must be connected to the fitting on the end of the flex tube as illustrated in the *Natural Gas Hose Attachment* diagram. Tighten using two wrenches. (*Do not use thread sealer/pipe dope.*) **These connections must be made by a licensed gas installer.** Leak test all joints prior to using the gas grill.

IMPORTANT

- The installation must be performed by a licensed gas fitter, and all connections must be leak tested before operating the grill.
- Do not route hose underneath drip pan.
- Do not route hose between space in bottom shelf and back panel.
- Do not route hose over top of back panel.
- Ensure all hose connections are tightened using two wrenches. Do not use teflon tape or pipe dope on any hose connection.
- Ensure the hose does not contact any high temperature surfaces, or it may melt and leak causing a fire.
- Do not use enclosure to store excess hose, as there is a greater chance of the hose contacting a hot surface, it may melt and leak causing a fire.
- Leak test all the connections using a soap and water solution, as per the leak testing instructions found in the this manual.

LIGHTING INSTRUCTIONS

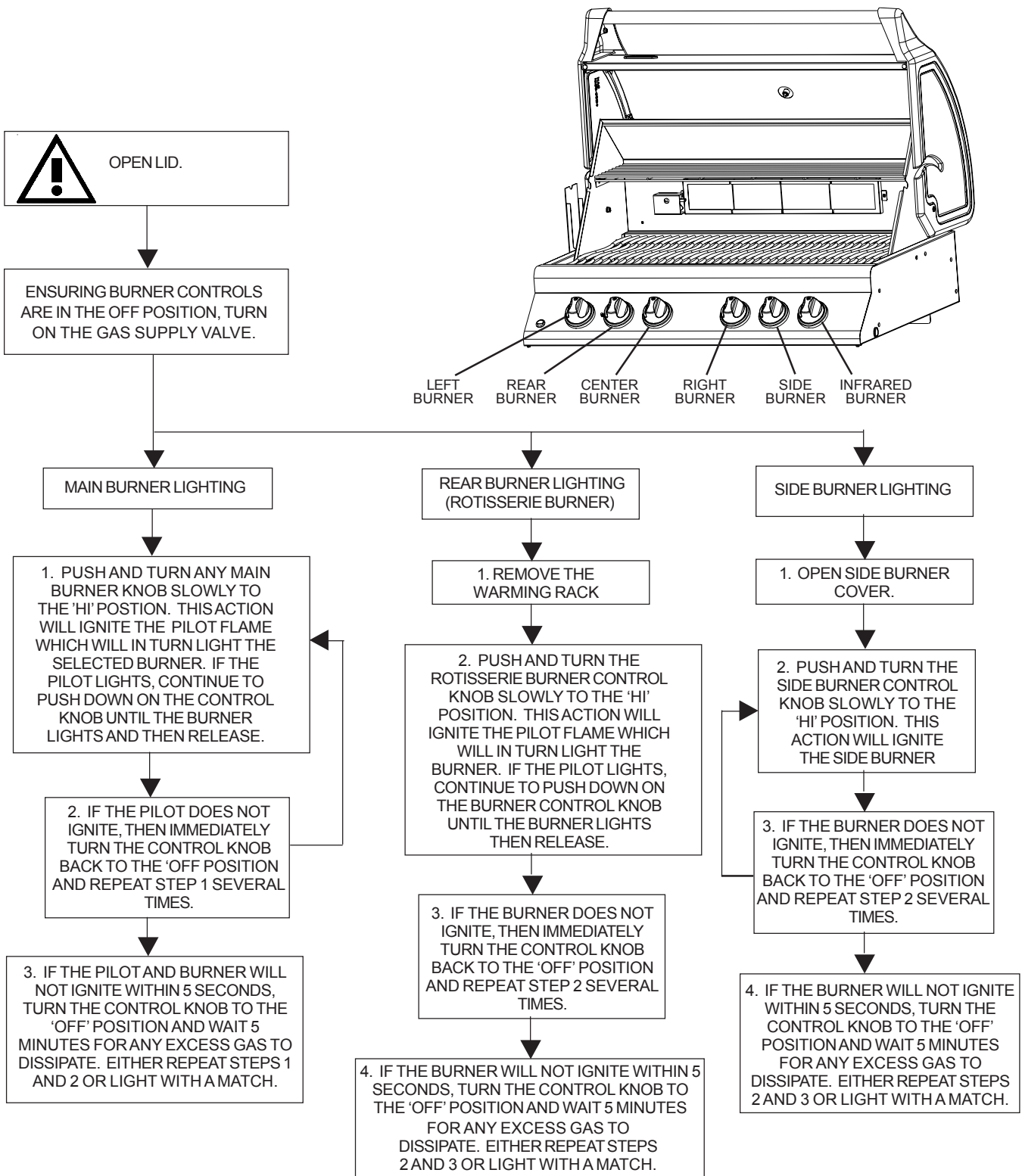

The propane cylinder is equipped with an excess flow device. Unless all burners are turned off prior to turning the cylinder on, only small flames will be achievable.

Do not use the rear burner (roasting burner) with the main burners operating.



If lighting the unit with a match, clip the match into the supplied lighting rod. Hold the lit match down through the grill and sear plate while turning the corresponding burner valve to high.



OPERATING THE GRILL

BURN - IN PROCEDURE

When lit for the first time, the gas grill will emit a slight odour. This is a normal temporary condition caused by the "burn-in" of internal paints and lubricants used in the manufacturing process and will not occur again. Simply run the main burners on high for approximately ½ hour with the lid closed.

MAIN BURNER USE:

When searing foods, preheating is recommended by operating all main burners in the high position with the lid closed for approximately 15 minutes. Food cooked for a short period of time (fish, vegetables) may be grilled with the lid open. Cooking with the lid closed will ensure higher, more even temperatures that will reduce cooking time and cook meat more evenly. When cooking very lean meats, such as chicken breasts, or lean pork, the grids can be oiled before pre-heating to reduce sticking. Cooking meat with a high degree of fat content, may create flare-ups. Either trim some fat or reduce temperatures to prevent this. Should a flare-up occur, move food away from flames, reduce heat. Leave the lid open. See 'Your All Season Grill' cookbook by Napoleon for more detailed instructions.

DIRECT COOKING:

Place food to be cooked on the grill directly over the heat. This method is generally used for searing or for foods that do not require prolonged cooking times - hamburgers, steaks, chicken pieces, vegetables, etc. The food is first seared to trap in the juices and flavor, and then the temperature is lowered to finish cooking the food to your preference.

INDIRECT COOKING:

With one or more burners operating place food to be cooked on the grill over one of the burners that is not operating. The heat circulates around the food, cooking slowly and evenly. Cooking in this manner is much the same as cooking in your oven and is generally used for larger cuts of meats such as roasts, chickens or turkeys, but can also be used for cooking foods that are prone to flare ups. Cooking in this method with lower temperatures and slower cooking times will result in tender foods every time you grill.

INFRARED MAIN BURNER USE:

1. Follow the infrared burner ignition procedures and operate on high for 5 minutes with the lid closed or until the ceramic burners glow red.
2. Place food on grills and cook according to times listed in the Infrared Grilling Chart.
3. Depending upon your taste, continue cooking over infrared burners on high, medium or low, turning food frequently, or place food away from infrared burners, close lid, and allow oven temperature to slowly finish cooking your food.

Caution: Due to the intense heat the infrared burners provide, food left unattended over burners will burn quickly. Keep the lid open when cooking with the infrared burners on high. The intense heat ensures adequate searing temperatures even with the lid open. This also allows observation of the food, so as to prevent burning.

PROTECTION OF YOUR INFRA RED BURNERS - The infrared burners of your grill are designed to provide a long service life. However, there are steps you must take to prevent cracking of their ceramic surfaces, which will cause the burners to malfunction.

- Never let water come in direct contact with your ceramic burner.
- Do not allow hard objects to impact the infra red burner.
- Do not allow cold water (rain, sprinkler, hose, etc.) to come in contact with hot ceramic burners. A large temperature differential can cause cracking of the ceramic tile.

Damage caused by failure to follow these steps is not covered by your grill warranty.

REAR BURNER USE:

Remove the warming rack prior to use. Cooking grids should also be removed if they interfere with the rotisserie. This gas grill is equipped with a 15,500 BTU rear burner. The rear burner is designed to be used in conjunction with the rotisserie kit available from your dealer. See the rotisserie kit assembly instructions. To use the counterbalance, remove the rotisserie motor from the gas grill. Place the spit with meat being cooked across the hangers inside the grill. The meat will naturally hang with the heavy side down. Tighten the counterbalance arm and weight, so that the arm is facing up. Slide the counterweight in or out to balance the load, and tighten in place. Re-install the motor and begin cooking. Place a dish underneath to collect drippings for basting and naturally delicious gravy. Basting liquid may be added as required. To seal in juices, first operate rear burner on high until browned, then reduce the heat to thoroughly cook foods. Keep the lid closed for best results. Your roasts and fowl will brown perfectly on the outside and stay moist and tender on the inside. For example, a 3 pound chicken on the rotisserie will be done in approximately 1½ hours on medium to high. See 'Your all Season Grill' cookbook by Napoleon for more detailed instructions.

SIDE BURNER USE:

The side burner can be used like any range top burner, for gravies, soups etc. The gas grill should be located so that the side burner is protected from the wind, because the wind will adversely affect it's performance. **DO NOT** use side burner to deep fry foods as cooking with oil can create a dangerous situation.

INFRARED HEAT

Most people don't realize that the heat source that we are most familiar with, namely the sun warms the earth using mainly infrared energy. Infrared energy is a form of electro-magnetic energy that has a wavelength just greater than the red end of the visible light spectrum, but less than that of radio waves. This energy was discovered in 1800 by Sir William Herschel who, dispersed sunlight into its component colours using a prism. He showed that most of the heat in the beam fell into the spectral region just beyond the red end of the spectrum, where no visible light existed. This is infrared energy. Most materials readily absorb infrared radiation in a wide range of wavelengths, causing an increase in temperatures of the materials. This is the same phenomenon that causes us to feel warmth when we are exposed to sunlight. The infrared rays from the sun travel through the vacuum of space, through the atmosphere and penetrate our skin. This causes increased molecular activity in the skin, which creates internal friction and generates heat, allowing us to feel warmth.

Foods cooked over infrared heat sources are heated by the same principle. Charcoal is the traditional way of infrared cooking that we are all familiar with. The glowing briquettes emit infrared energy to the food being cooked, with very little drying effect. Any juices or oils that escape from the food drip down onto the charcoal and vaporize into smoke giving the food its delicious grilled taste. The Napoleon infrared burner cooks in the same way. In each burner, 10000 ports each with its own tiny flame cause the surface of the ceramic to glow red. This glow emits the same type of infrared heat to the food, without the hassle or mess of charcoal. It also provides a more consistent heated area that is far easier to regulate than a charcoal fire. For instantaneous searing the burners can be set to high, yet they can also be turned down for slower cooking. We all know how difficult that is on a charcoal fire. Traditional gas burners heat the food in a different way. The air surrounding the burner is heated by the combustion process and then rises up to the food being cooked. This generates lower grill temperatures that are ideal for more delicate cuisine such as seafood or vegetables. The bottom line is that Napoleon's infrared burners produce searing heat for juicier, tastier steaks, hamburgers and other meats. For cooking times and tips refer to the Infrared Grilling Chart.

INFRARED GRILLING CHART

FOOD	CONTROL SETTING	COOKING TIME	HELPFUL SUGGESTIONS
Steak 1" Thick	High setting 2 min. each side High setting 2 min. each side then medium setting High setting 2 min. each side then medium setting	4 min. - Rare 6 min. - Medium 8 min. - Well Done	When selecting meat for grilling, ask for meat with a marbled fat distribution. The fat acts as a natural tenderizer while cooking and will keep the meat moist and juicy.
Hamburger 1/2" Thick	High setting 2 min. each side High setting 2 1/2 min. each side High setting 3 min. each side	4 min. - Rare 5 min. - Medium 6 min. - Well Done	Preparing hamburgers to order is made easier by varying the thickness of your patties. To add an exotic taste to your meat, try adding hickory-flavored woodchips into Napoleon's woodchip smoker.
Chicken Pieces	High setting 2 min. each side medium-low to low setting	20-25 min.	The joint connecting the thigh and the leg from the skinless side, should be sliced 3/4 of the way though in order for the meat to lay flatter on the grill. This will help it to cook faster and more evenly. To add a trademark taste to your cooking, try adding mesquite-flavoured woodchips in your Napoleon woodchip smoker.
Pork Chops	Medium	6 min. per side	Trim off the excess fat before grilling. Choose thicker chops to get more tender meat.
Spare Ribs	High setting for 5 minutes low to finish	20 min. per side turn often	Choose ribs that are lean and meaty. Grill until meat easily pulls away from the bone.
Lamb Chops	High setting for 5 minutes medium to finish	15 min. per side	Trim off the excess fat before grilling. Choose extra thick chops to get more tender meat.
Hot Dogs	Medium - Low	4-6 min.	Select the larger size wieners. Slit the skin lengthwise before grilling.

MAINTENANCE/CLEANING INSTRUCTIONS

It is recommended that this gas grill be thoroughly inspected and serviced annually by a qualified service person.

Note: Stainless steel tends to oxidize or stain in the presence of chlorides and sulfides, particularly in coastal areas and other harsh environments, such as the warm, high humidity atmosphere around pools and hot tubs. These stains may be perceived as rust, but can be easily removed and prevented. To ensure stain prevention, wash all stainless steel surfaces every 3-4 weeks with fresh water and stainless steel cleaner or as often as required.

- Do not use a pressure washer to clean any part of the unit.
- Ensure that the burners are turned off prior to cleaning. Avoid unprotected contact with hot surfaces. Clean grill in an area where cleaning solutions will not harm decks, lawns or patios. Do not use oven cleaner to clean any part of this gas grill. Do not use a self cleaning oven to clean cooking grids or any other parts of the gas grill. Barbecue sauce and salt can be corrosive and will cause rapid deterioration of the gas grill components unless cleaned regularly.
- Turn off the gas at the source and disconnect unit before servicing. Maintenance should only be done when the grill is cool, to avoid the possibility of burns. A leak test must be performed annually, and whenever any component of the gas train is replaced.

COMBUSTION AIR ADJUSTMENT - (This must be done by a qualified gas installer.) The air shutter is factory set and should not have to be adjusted under normal conditions. However, some extreme field conditions may exist that require adjustment. When the air shutter is adjusted correctly, the flames will be dark blue with light blue tips, and occasional yellow tips.

If the burner is getting too little air, the flames will be lazy yellow, and possibly produce soot. If the burner is getting too much air, the flames will be lifting erratically from the burner and may cause difficulties when lighting.

1. To adjust the air shutter, remove cooking grids and sear plates and leave lid open. The back cover must be removed for back burner air shutter adjustment.

2. Loosen air-shutter lock screw and open or close air shutter as required. The normal settings are:

Main Burner	Propane	5/32"
	Natural	5/32"

3. Light burners and set to high. Visually inspect burner flames. When shutters are set, turn burners off, tighten locking screw, and replace removed parts. Ensure that the insect screens are installed.

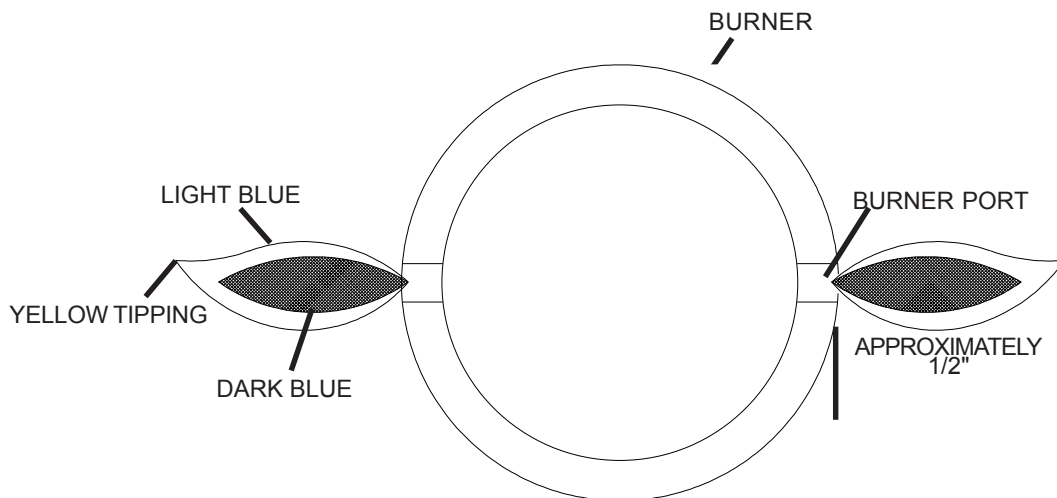

GRIDS AND WARMING RACK - The grids and warming rack are best cleaned during the pre-heat period with a soft brass wire brush. Steel wool can be used for stubborn stains.

CLEANING INSIDE THE GAS GRILL - Remove cooking grids. Use a soft brass wire brush to clean loose debris from casting sides and insides of the lid. Scrape sear plates with a putty knife or scraper, and use a wire brush to remove ash. Remove sear plates and brush debris off of burners with a brass wire brush. Brush all debris from inside the gas grill into the removable drip pan. Ensure that the sear plates are placed properly when they are reinstalled (Check assembly instructions for proper orientation).

DRIP PAN - Slide the drip pan out for easy cleaning. It should be cleaned frequently (every 4-5 uses) to avoid grease buildup. Grease and excess drippings pass through to the drip pan, located under the gas grill, and accumulate in the disposable grease tray below the drip pan. Accumulated grease can cause a fire hazard. Do not line the drip pan with aluminum foil, sand or any other material, as it can prevent the grease from flowing properly. The pan should be scraped out with a putty knife or scraper, and all the debris should be scraped into the disposable grease tray. This tray should be replaced every two to four weeks, depending on gas grill usage. For supplies, see your Napoleon Gas Grill dealer.

MAINTENANCE/CLEANING INSTRUCTIONS

HOSE - Check for abrasion, melting, cuts and cracks. If any of these conditions exist, do not use gas grill. Have part replaced by your Napoleon Gas Grill dealer, or qualified gas installer.

CLEANING THE OUTSIDE OF THE GAS GRILL - Do not use abrasive cleaners to clean any painted, porcelain or stainless steel parts. Porcelain enamel components must be handled with additional care. The baked on enamel finish is glass like, and will chip if struck. Touch-up enamel is available from your Napoleon Gas Grill dealer. Exterior grill surfaces should be cleaned while warm to the touch, with warm soapy water. To clean stainless surfaces, use a stainless steel cleaner or a non-abrasive cleaner. Always wipe in the direction of the grain. Do not use steel wool, as it will scratch the finish. Stainless steel parts will discolour when heated, usually to a golden or brown colour. This discolouration is normal and will not affect the performance of the grill.

TUBE BURNER - The burner is made from heavy wall 304 stainless steel, but due to the extreme heat and corrosive environment, surface corrosion will occur. Use a brass wire brush to remove surface corrosion. Clean any blocked ports using an opened paper clip. Do not enlarge the burner ports. Spiders and insects are attracted to the smell of propane and natural gas. The burner is equipped with an insect screen on the air shutter, which will reduce the likelihood of insects building nests inside the burner, but does not entirely eliminate the problem. The nest or web will cause the burner to burn with a soft yellow or orange flame or cause a fire (flashback) at the air shutter underneath the control panel. To clean the inside of the burner, it must be removed from the gas grill. Remove the screw located in the center of each burner. Lift the back of the burner upwards to remove. Use a flexible venturi tube cleaning brush to clean out the inside of the burner. Shake any loose debris out of the burner, through the gas inlet. Ensure that the insect screen is clean, tight, and free of any lint or other debris. Check also that the valve orifices are clean. Do not enlarge the orifices. Re-install the burner.



CAUTION BEWARE OF SPIDERS

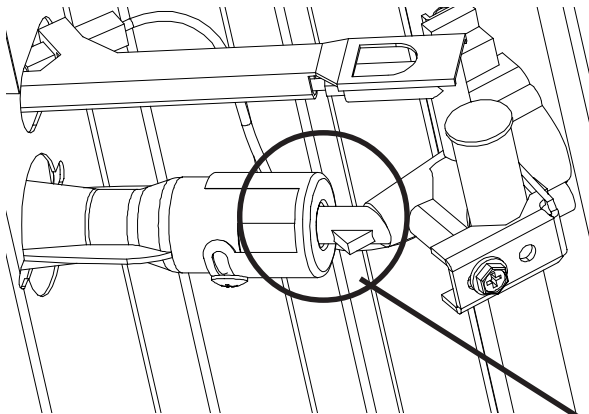
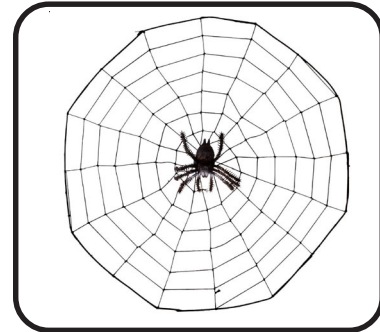

WARNING

It is very important when re-installing the burner after cleaning that the valve/orifice enters the burner tube before lighting your gas grill. If the valve is not inside the burner tube a fire or explosion could occur.

INFRA RED BURNER - Because of the high intensity of the infrared burner, most drippings and food particles that fall onto the burner surface are immediately incinerated. However, some debris and residue may remain. To remove this residue after cooking, turn the grill on high with lid closed for 5-10 minutes. Never use a brush or pressure washer to clean the infra red burners.

TROUBLESHOOTING

Problem	Possible Causes	Solution
Low heat / Low flame when valve turned to high.	<p>For propane - improper lighting procedure.</p> <p>For natural gas - undersized supply line.</p> <p>For both gases - improper preheating.</p>	<p>Ensure lighting procedure is followed carefully. All gas grill valves must be in the off position when the tank valve is turned on. Turn tank on slowly to allow pressure to equalize. See lighting instructions.</p> <p>Pipe must be sized according to installation code.</p> <p>Pre-heat grill with all main burners on high for 10 to 15 minutes.</p>
Excessive flare-ups/uneven heat.	<p>Sear plates installed incorrectly.</p> <p>Improper pre-heating.</p> <p>Excessive grease and ash build up on sear plates and in drip pan.</p>	<p>Ensure sear plates are installed with the holes towards the front, and the slots on the bottom. See assembly instructions.</p> <p>Pre-heat grill with both main burners on high for 10 to 15 minutes.</p> <p>Clean sear plates and drip pan regularly. Do not line pan with aluminum foil or other materials. Refer to cleaning instructions.</p>
Burners burn with yellow flame, accompanied by the smell of gas.	Possible spider web or other debris, or improper air shutter adjustment.	Thoroughly clean burner by removing. See general maintenance instructions. Open air shutter slightly according to combustion air adjustment instructions. (This must be done by a qualified gas installer.)
Flames lift away from burner, accompanied by the smell of gas, and possibly difficulties in lighting.	Improper air shutter adjustment.	Close air shutter slightly according to combustion air adjustment instructions. (This must be done by a qualified gas installer.)
Regulator 'Hums' when unit is operating.	Normal occurrence on hot days.	This is not a defect. It is caused by internal vibrations in the regulator, and does not affect the performance or safety of the gas grill. Humming regulators will not be replaced.
Burners will not crosslight each other.	Plugged ports at back of burner.	Clean burner ports. See burner maintenance instructions.
"Paint" appears to be peeling inside lid or hood.	Grease build up on inside surfaces.	This is not a defect. The peeling is caused by hardened grease, which dries into paint-like shards, that will flake off. Regular cleaning will prevent this. See cleaning instructions.
Infrared burner flashes back (during operation the burner abruptly makes a loud "whoosh" sound, followed by a continuous blow-torch type sound and grows dim.)	<p>Ceramic tiles overloaded with grease drippings and build-up, ports are clogged.</p> <p>Burner overheated due to inadequate ventilation (too much grill surface covered by griddle or pan.)</p> <p>Cracked ceramic tile.</p> <p>Leaking gasket surrounding the ceramic tile, or a weld failure in the burner housing.</p>	<p>Turn burner off and allow to cool for at least two minutes. Relight burner and burn on high for at least five minutes or until the ceramic tiles are evenly glowing red.</p> <p>Ensure that no more than 75% of the grill surface is covered by objects or accessories. Turn burner off and allow to cool for at least two minutes, then relight.</p> <p>Allow burner to cool and inspect very closely for cracks. If any cracks are found, contact your authorized Napoleon dealer for ordering a replacement burner assembly.</p> <p>Contact your authorized Napoleon dealer for instructions on ordering a replacement burner assembly.</p>

ASSEMBLY INSTRUCTIONS

⚠ CAUTION: During unpacking and assembly it is recommended that you wear work gloves and safety glasses for your protection. Although we make every effort to make the assembly process as problem free and safe as possible, it is characteristic of fabricated steel parts that the edges and corners may be sharp and can cause cuts if handled incorrectly during assembly.

GETTING STARTED

1. Remove all cart panels, hardware, and grill head from carton. Raise lid and remove any components packed inside. Use the parts list to ensure all necessary parts are included.
2. Do not destroy packaging until grill has been fully assembled and operates to your satisfaction.
3. Assemble BBQ where it is to be used, lay down cardboard or a towel to protect parts from being lost or damaged while assembling.
4. Most stainless steel parts are supplied with a protective plastic coating that must be removed prior to using grill.
5. Follow all instructions in the order that they are laid out in this manual.
6. Two people are required to lift the grill head onto the assembled cart.

TOOLS REQUIRED FOR ASSEMBLY (tools not included)

3/8 (10mm)
WRENCH,
RATCHET OR
DRIVER

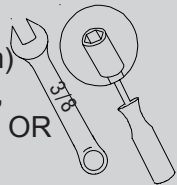

7/16
WRENCH,
RATCHET OR
DRIVER

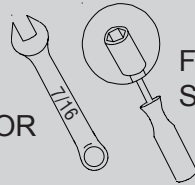

FLAT AND PHILIPS
SCREWDRIVERS

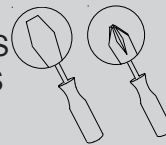

HAMMER



If you have any questions about assembly or grill operation, or if there are damaged or missing parts please call our customer care department at 1-866-820-8686 between 9 AM and 5 PM (Eastern Standard Time).

2 x N430-0002
MAGNET CATCH

1 Magnet Installation

Snap magnets into slots in front of bottom shelf.

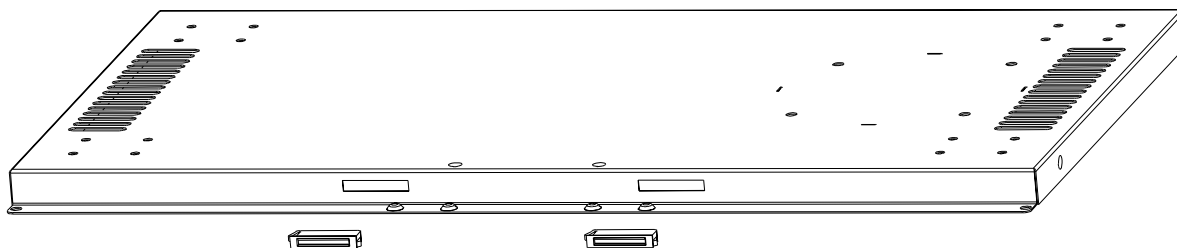

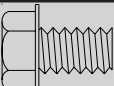
16 X 
N570-0073 (1/4-20 X 3/8")

16 X 
N450-0027 (1/4-20)

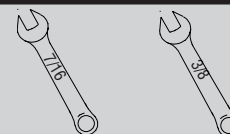

2 Caster Installation

Attach (4) casters using (4) 1/4 - 20 X 3/8" screws and (4) 1/4-20 lock nuts for each caster. Attach brackets under front casters as illustrated below. Tighten securely.

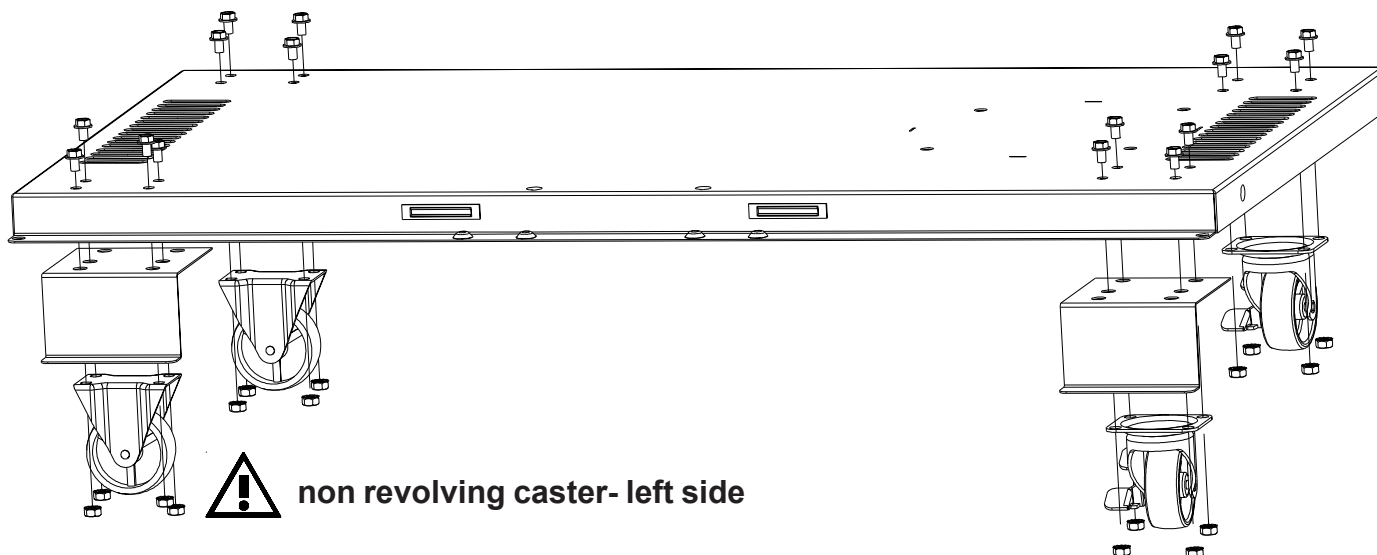



PROPANE ONLY

3 Propane Tank Ring Installation

Insert propane tank ring into slots in bottom shelf as shown. Fold tabs over to secure in place.

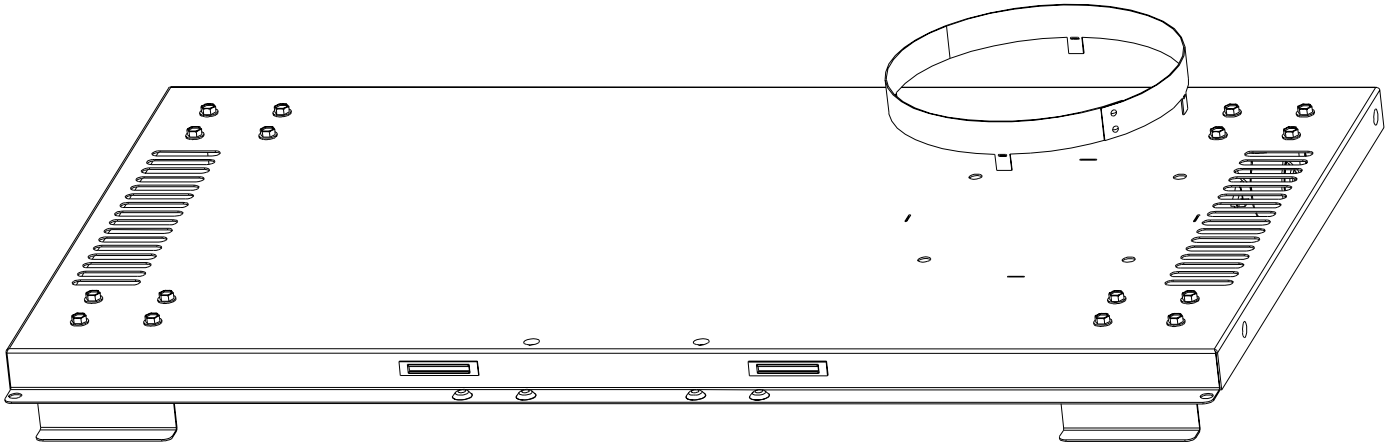

4 X

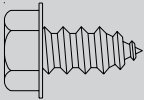

N570-0080 (#14 X 1/2")

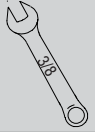

4 Left and Right Cart Panel Installation

Install end cart panels ensuring slots in panel are to the top, rest panel on bottom shelf and line up holes. Fasten using (4) #14 x 1/2" screws.

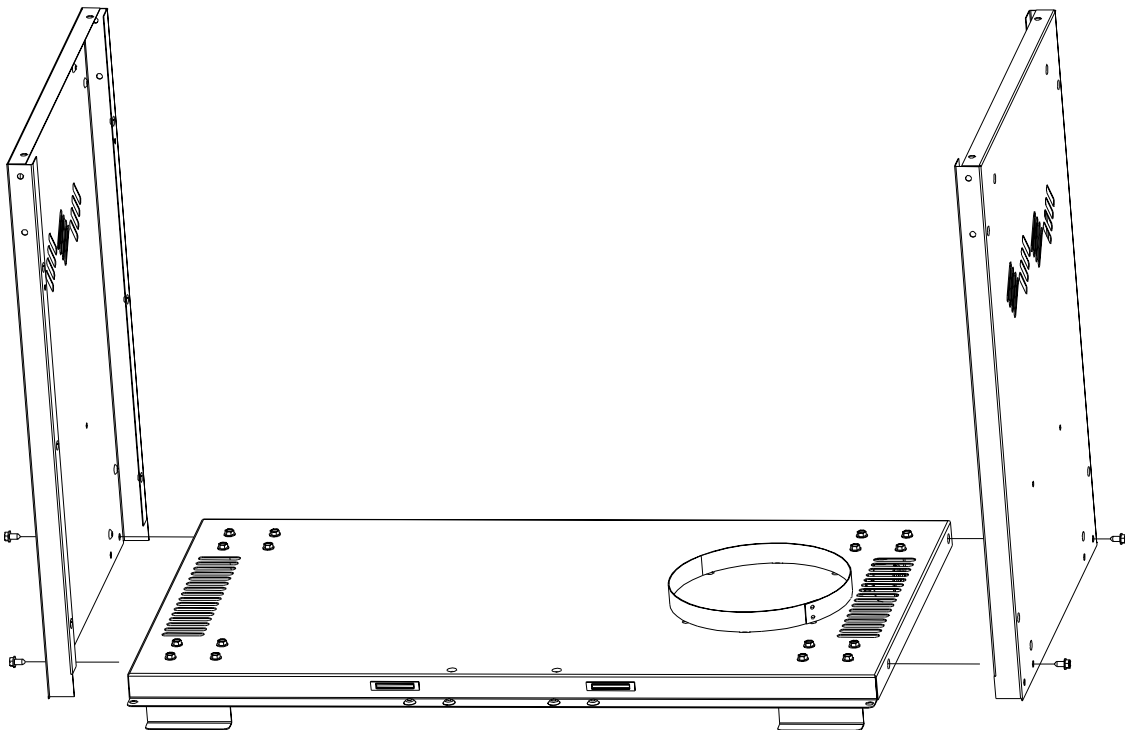

6 X

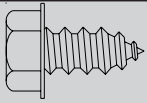

N570-0080 (#14 X 1/2")

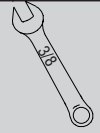

5 Rear Cart Panel Installation

Fit rear cart panel between the two end panels, ensure large hole in panel is to the bottom right hand corner as illustrated. Fasten using (6) #14 x 1/2" screws, three on each side.

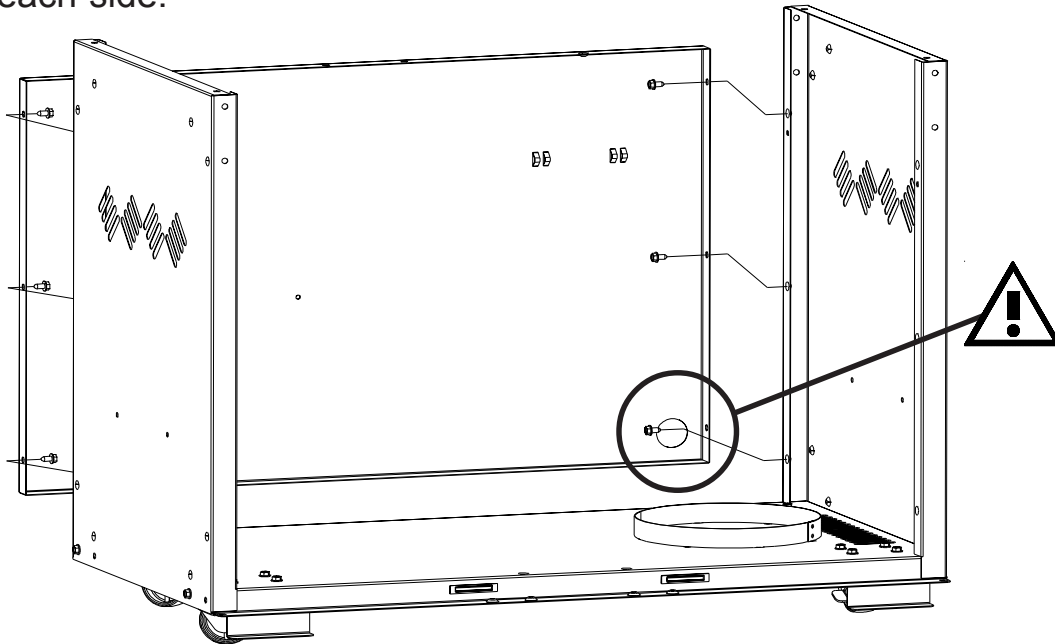

6 Condiment Basket / Propane Tank Mount Installation

Rotate basket slightly to allow wire to enter the holes in the side panel. Push through and upwards, rotating to allow the bend in the wire to pass through the holes. Lay basket flat against the side panel. Clip top propane tank mount into slots in back panel. Insert one end at a time, gently bending wire. (When not in use tank mount will lay flat against back panel).

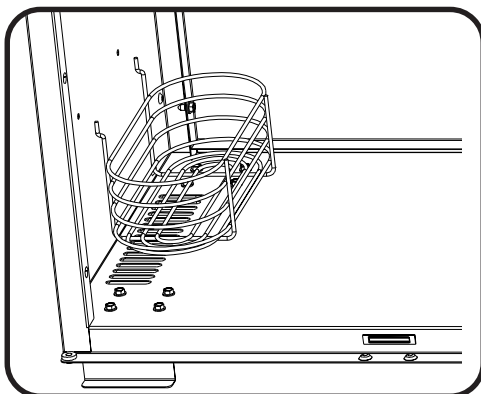

PROPANE ONLY

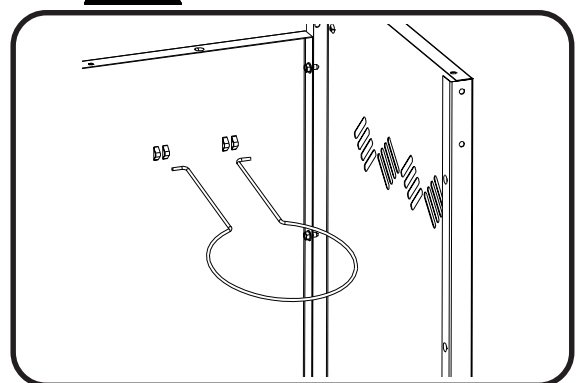

8 X

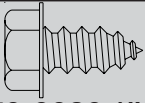

N570-0080 (#14 X 1/2")

2 x N430-0002
MAGNET CATCH

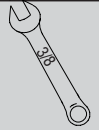

7 Front Cabinet Support Installation

Fasten top rail assembly to the front of side panels using (4) #14 x 1/2" screws. For ease of installation, start all screws before tightening completely. Attach magnet brackets to bottom of top rail using (2) #14 x 1/2" screws per bracket, and snap magnets into place as shown.

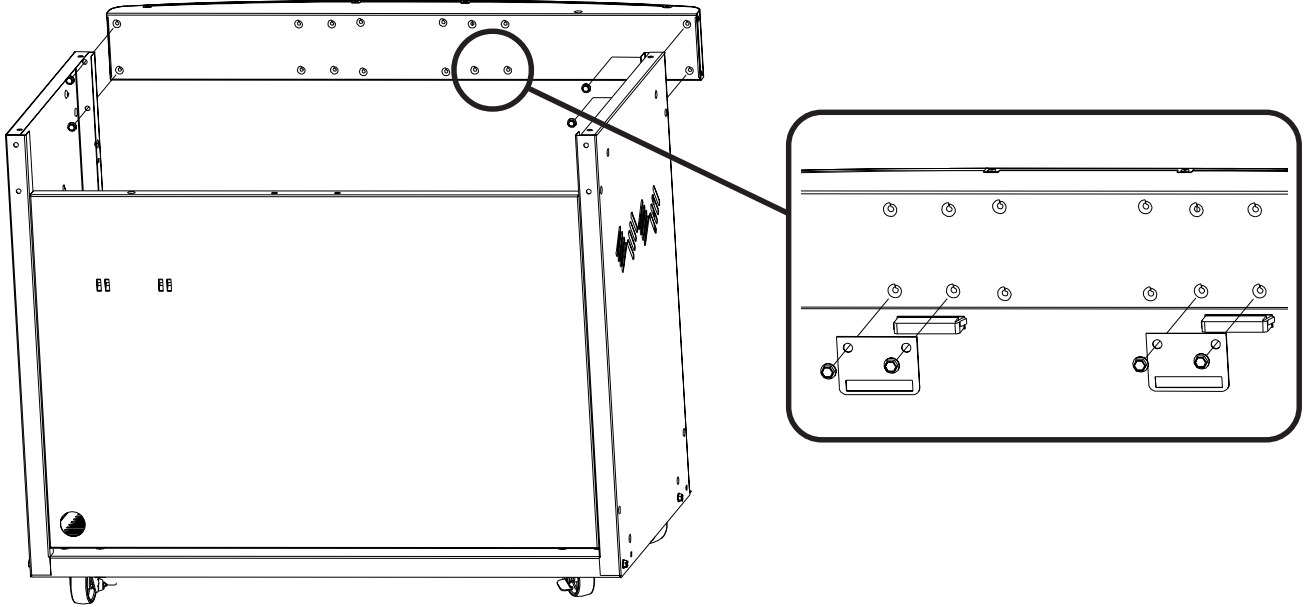

2 X

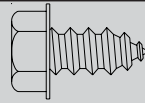

N570-0080 (#14 X 1/2")



PROPANE ONLY

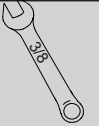

8 Propane Tank Heat Shield Installation

Attach propane tank heat shield above propane tank ring. Attach one end under lip of back panel in hole provided and other end to underside of front cabinet support.

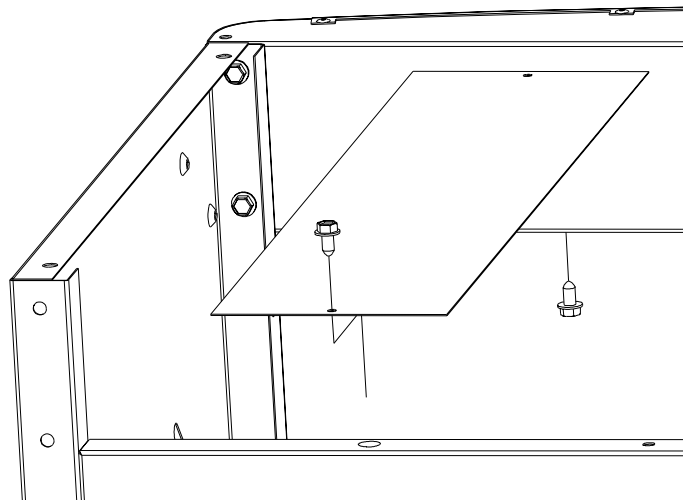

6 x

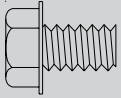

N570-0073 (1/4-20 x 3/8")

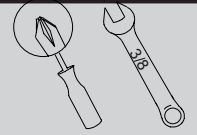

9 Grill Head Installation

⚠️ PROPANE ONLY - To avoid assembly difficulties, prior to mounting the grill head, remove zip tie holding regulator up under control panel. This was installed at the factory to protect the regulator hose during shipping and is no longer required. (Take care when removing the tie not to damage the hose). Ensure the regulator drops into the small opening, between the tank heat shield and the right side of the cabinet.

Lift grill head and place on assembled cart, lining up holes in top of side cart panels with holes in bottom of base. Fasten from inside using (4) 1/4-20 x 3/8" screws, two per side. Install battery pack below vent slots on left hand panel using magnet supplied with battery pack. Plug wire from LED (lights) located underneath control panel into wire from battery pack. Install rotisserie mount bracket to left side of barbecue as shown using (2) 1/4-20 x 3/8" screws.

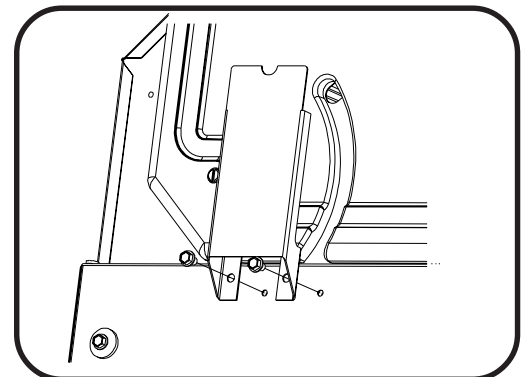
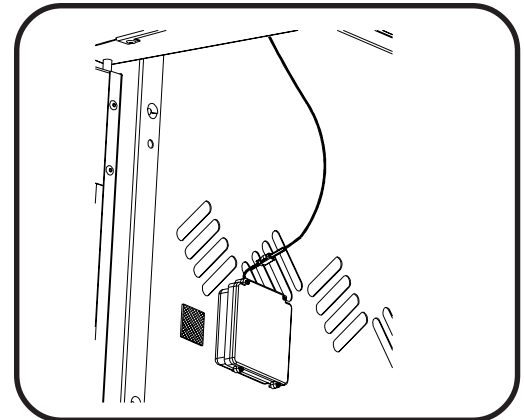
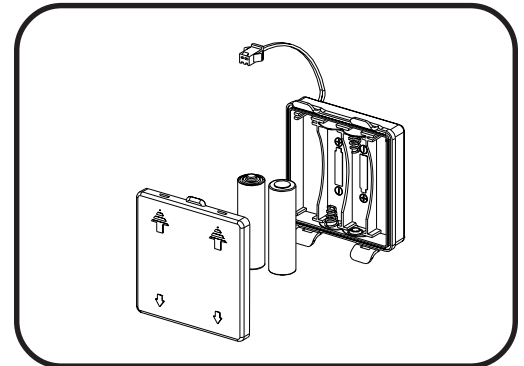
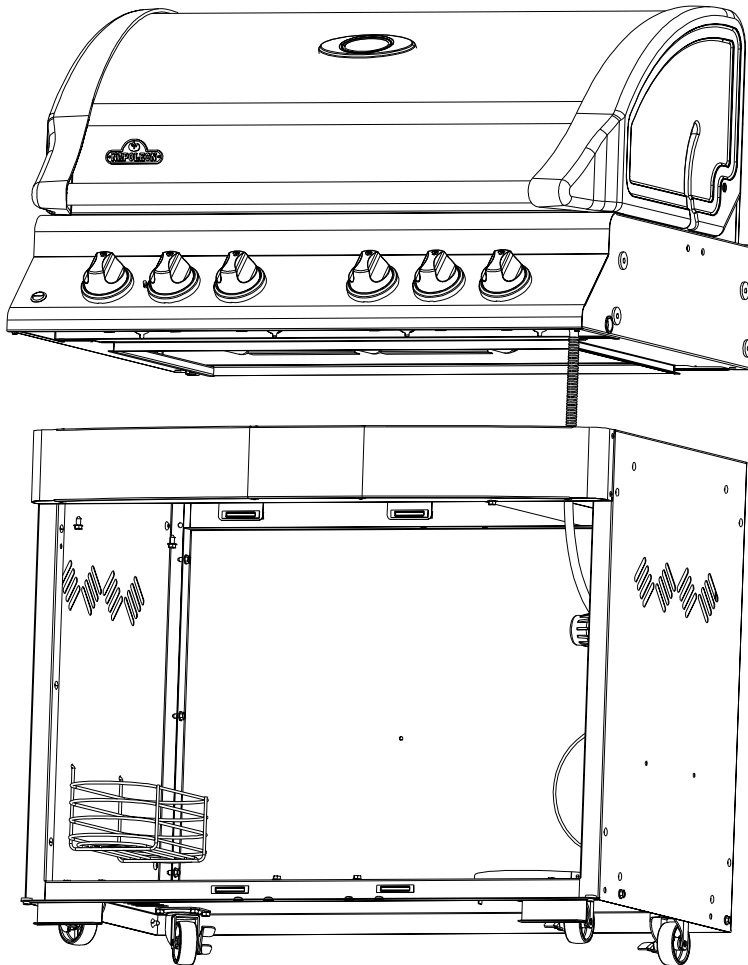

**TWO PEOPLE ARE REQUIRED
FOR THIS STEP**

10 x

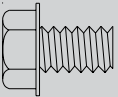

N570-0073 (1/4-20 x 3/8")

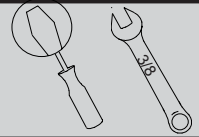

10 Assembling End Caps to Side Shelf / Side Burner

Peel protective coating from side shelf / side burner. Attach corresponding end cap as shown using (5) 1/4-20 x 3/8" screws.

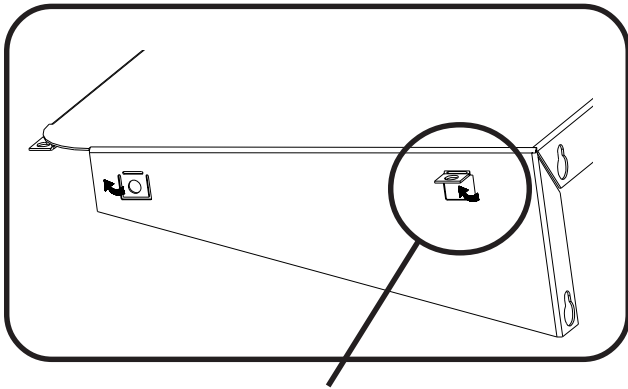

Bend Tabs on front of shelf up with a flat head screw driver, insert screw through tab and into end cap.

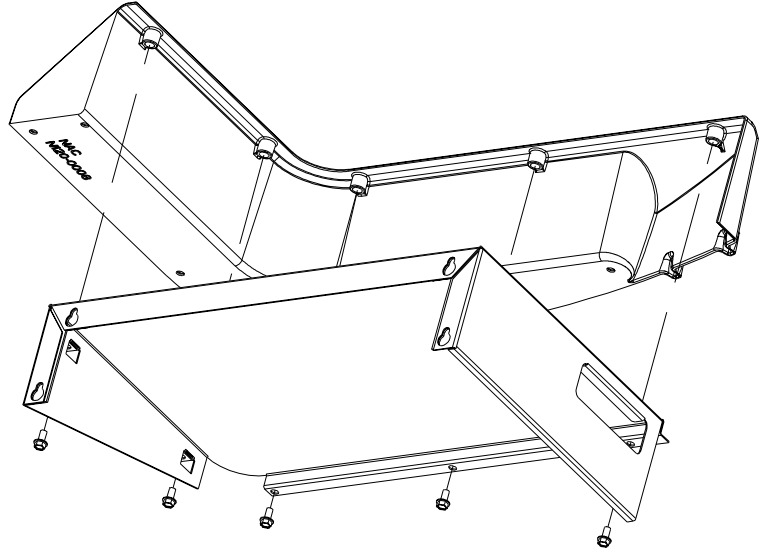

4 X

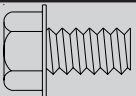

N570-0082 (1/4-20 x 5/8")

4 X



N735-0001 (1 1/16" insulated washer)

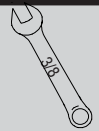

11 Side Shelf Installation

Insert (4) 1/4-20 x 5/8" screws through washers into threaded holes in side of base, do not tighten all the way. Slide assembled side shelf over screw heads and finish tightening.

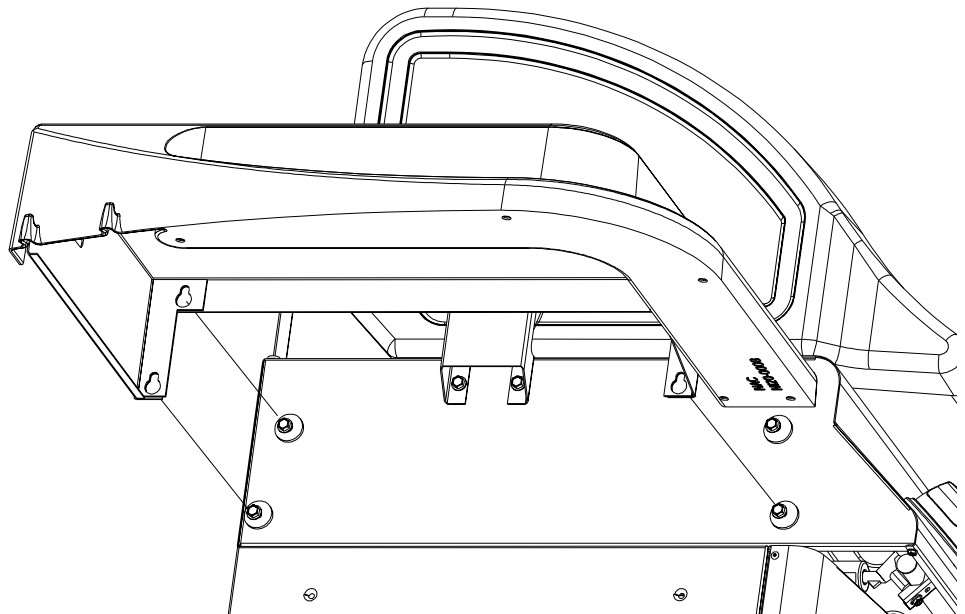
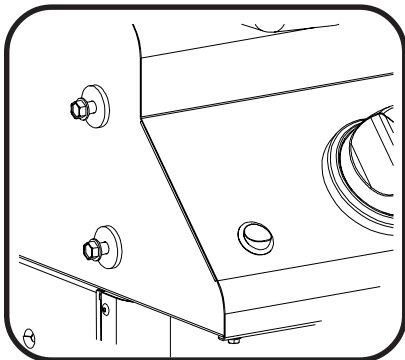

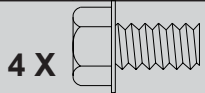

4 X
N570-0082 (1/4-20 x 5/8")

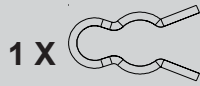

1 X
N160-0016



4 X
N735-0001 (1 1/16" insulated washer)



12 Side Burner Installation

Insert (4) 1/4-20 x 5/8" screws through washers into threaded holes in side of base. Do not tighten all the way. Slide assembled side burner over screw heads and finish tightening. Fit orifice into burner tube and secure with hose retainer clip supplied. Attach wire from manifold to side burner electrode.

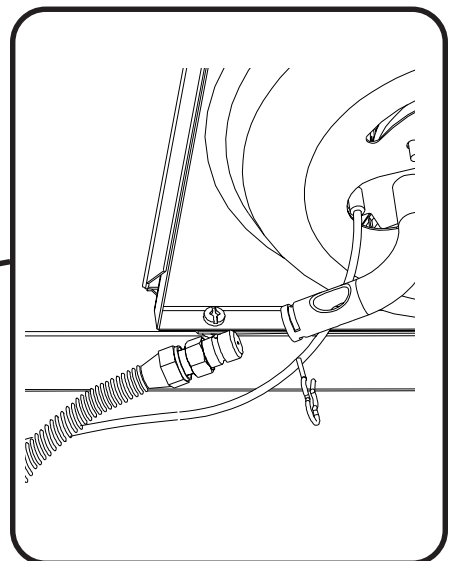
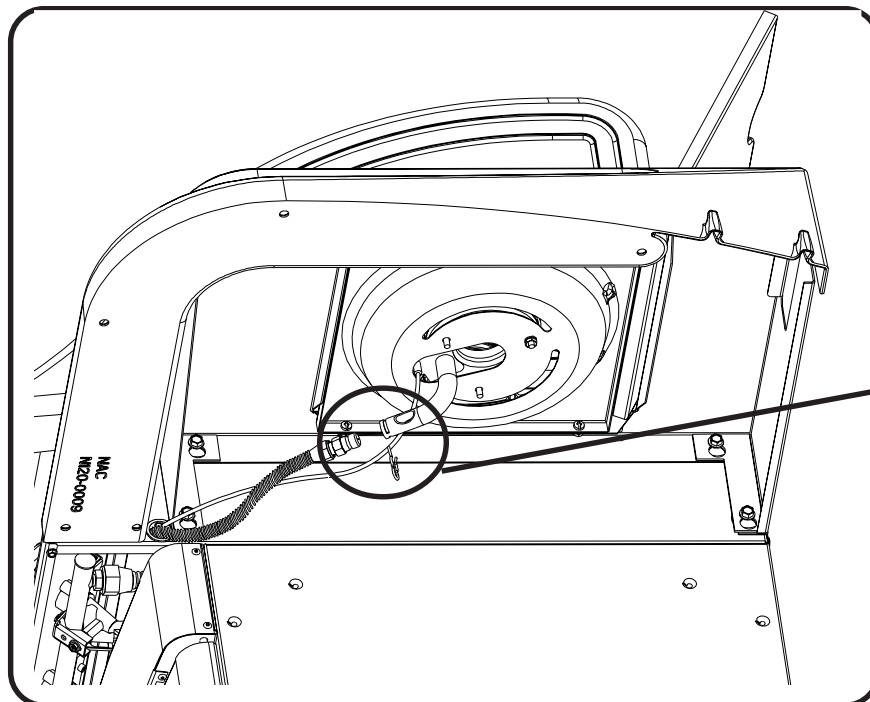
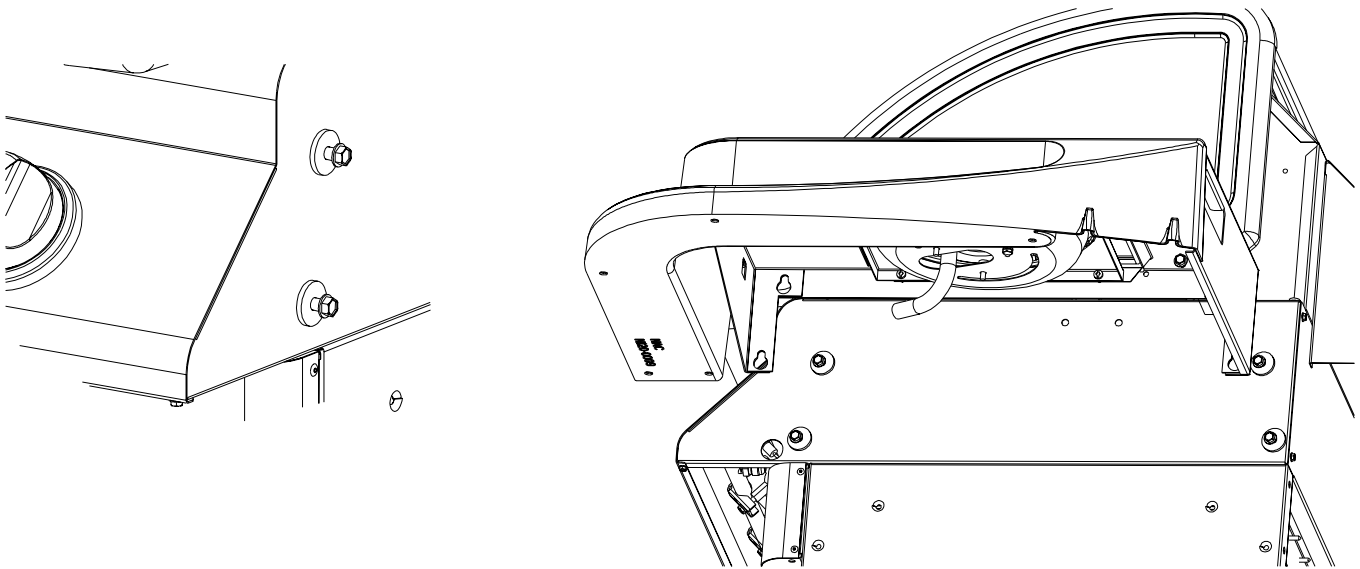

4 X

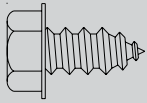

N570-0080 (#14 X 1/2")

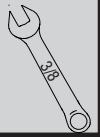

13 Front Fascia Installation

Attach front fascia to center of support beam. Slide top of fascia up under support beam as shown, resting bottom on bottom shelf. Fasten with (4) #14 x 1/2" screws.

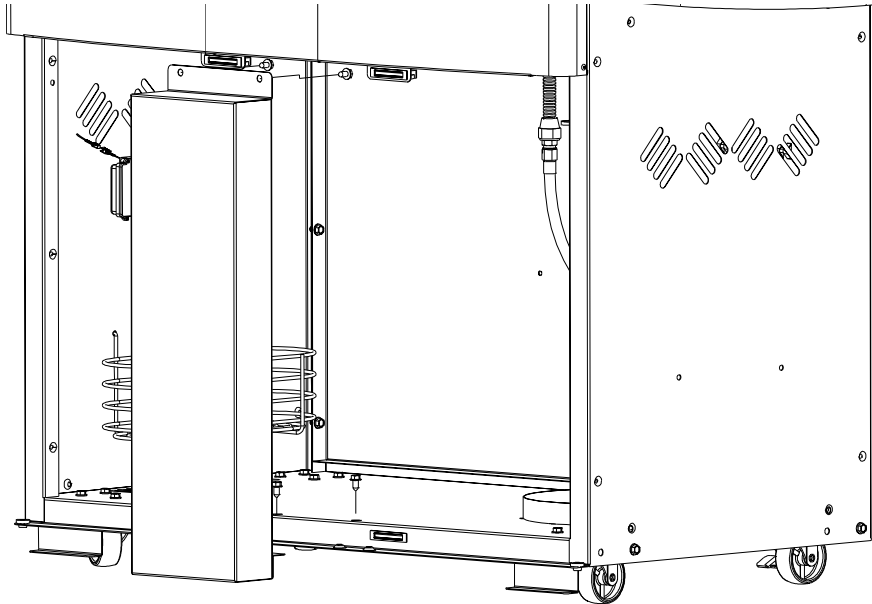

PROPANE ONLY

14 Tank Inhibitor Rod Installation

Insert one end of tank inhibitor rod into hole in back panel and other end into hole in back side of fascia as illustrated.

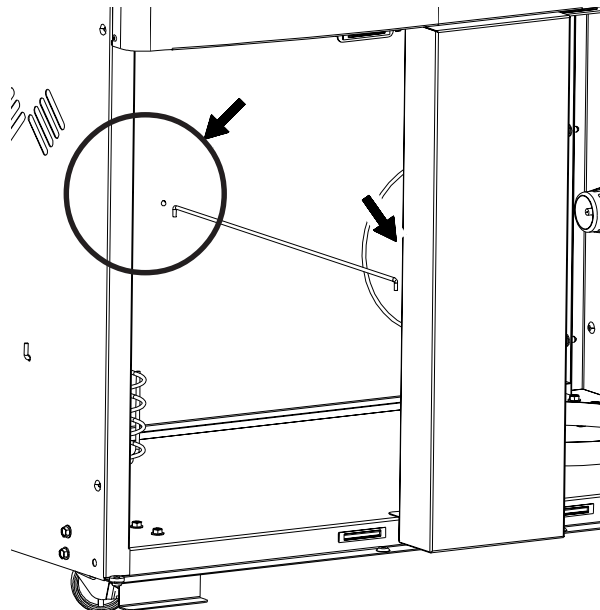

16 X

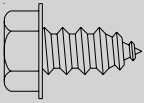

N570-0080 (#14 X 1/2")

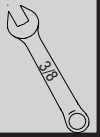

15 Assembling Side Enclosures

Take (1) side enclosure panel and place on solid surface. Fasten top and bottom to side using (8) #14 x 1/2" screws. Repeat for other side.

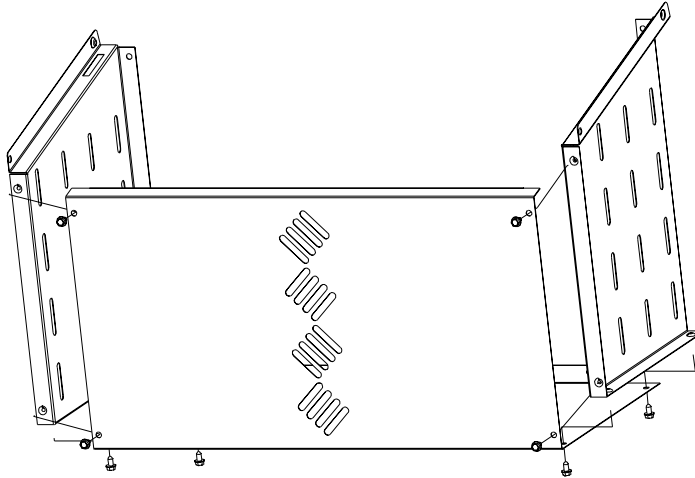

12 X

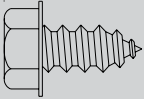

N570-0080 (#14 X 1/2")

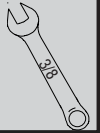

16 Side Enclosure Installation

Insert (2) #14 x 1/2" screws into holes in back of side cabinet panel as shown. Do not tighten. Slide enclosure over two screw heads, hold in place and insert (4) #14 x 1/2" screws into remaining holes. Tighten all screws. Repeat for other side.

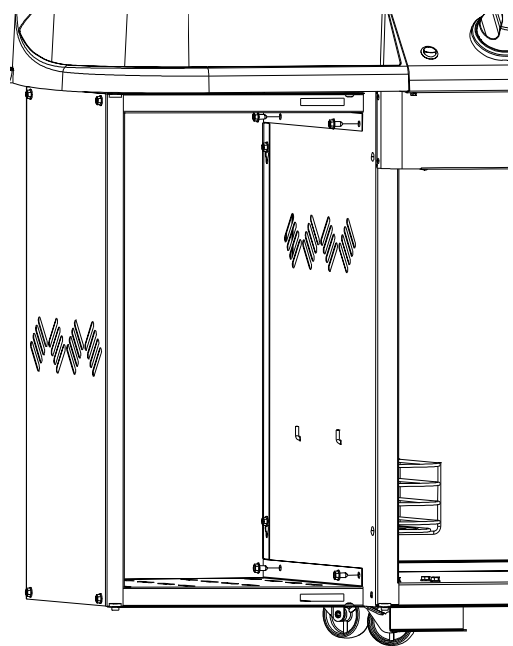
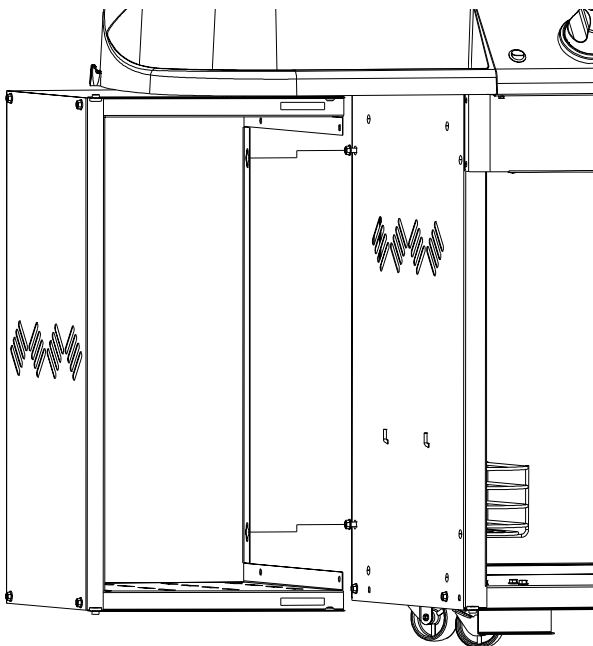

8 x N120-0010
THREAD CAPS

17 Thread Cap Installation

Attach the supplied thread caps to the threads of the screws inside your grill cabinet as illustrated, both top and bottom.

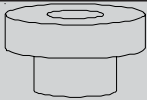
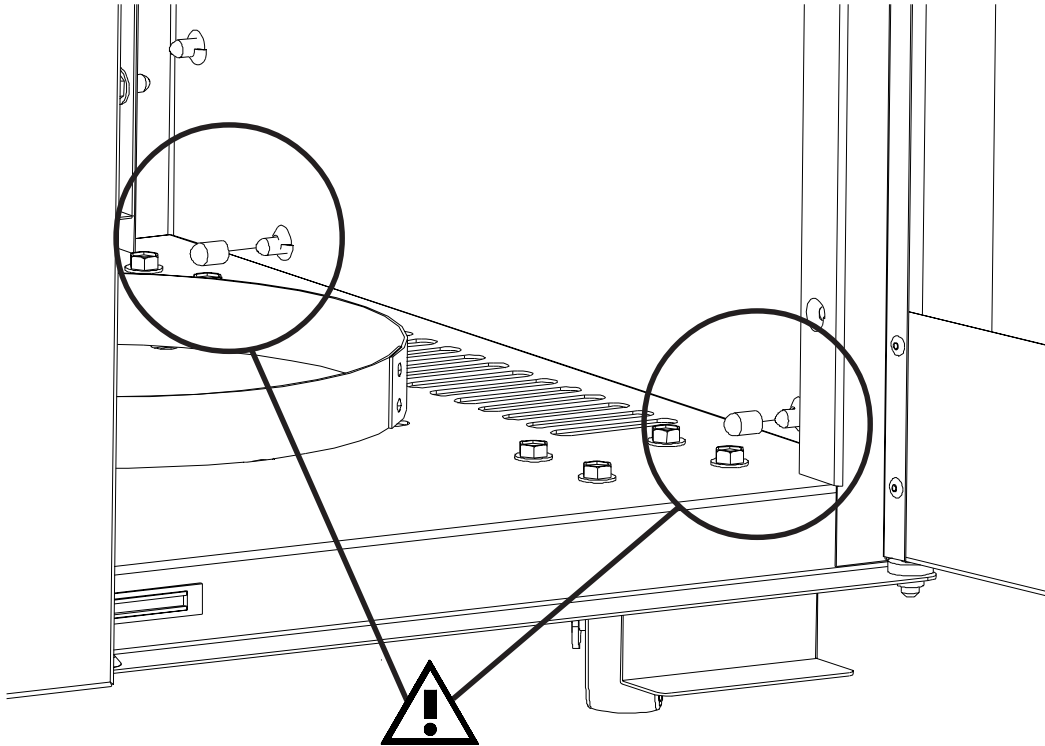

6 x N105-0011 DOOR BUSHING

4 x N430-0002
MAGNET CATCH

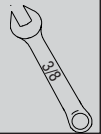

18 Bushing and Magnet Installation

Insert bushing into either end of bottom shelf and into either end of side enclosures both top and bottom. Snap remaining magnets into top and bottom of enclosures.

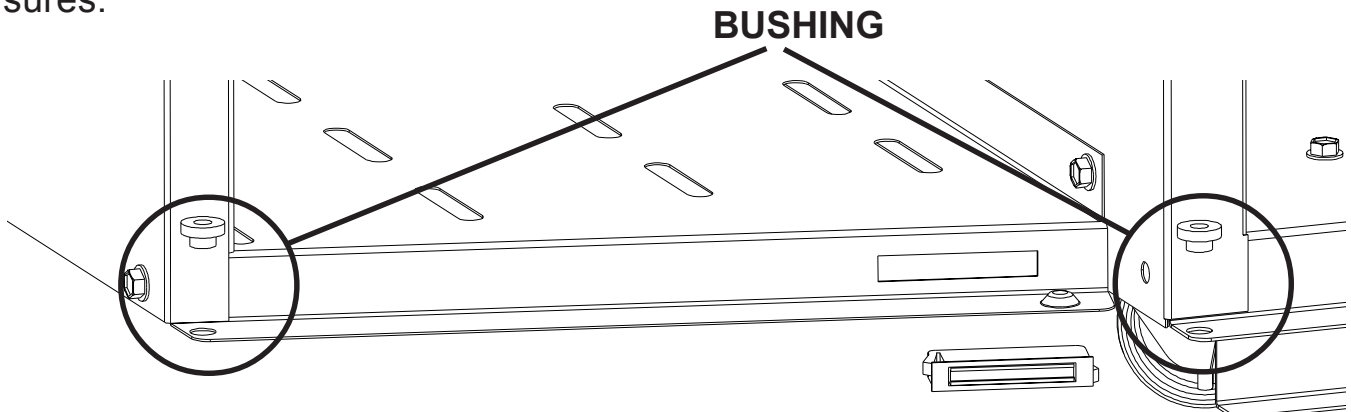

4 x N570-0073
(1/4-20 X 3/8")

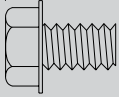

4 X N735-0003
(1/4" LOCK WASHER)

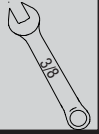

19 Cabinet Door Installation

Install door handle onto front of door using (2) 1/4-20 x 3/8" screws and (2) 1/4" washers per door.

Insert pivot rod through hole on inside top of door. Holding door in one hand, direct pivot rod into hole in underside of front beam. Once secure, let rod slide down and through hole in bottom of door and into bushing in bottom shelf.

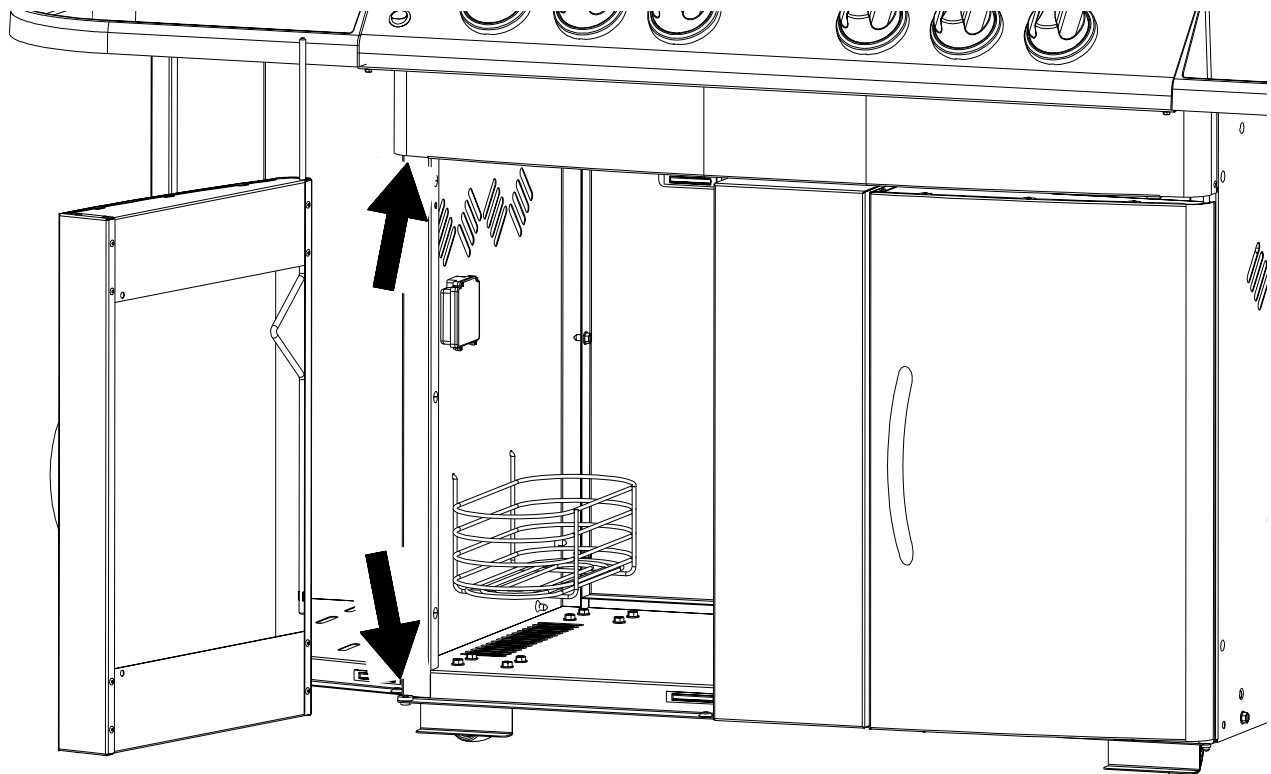
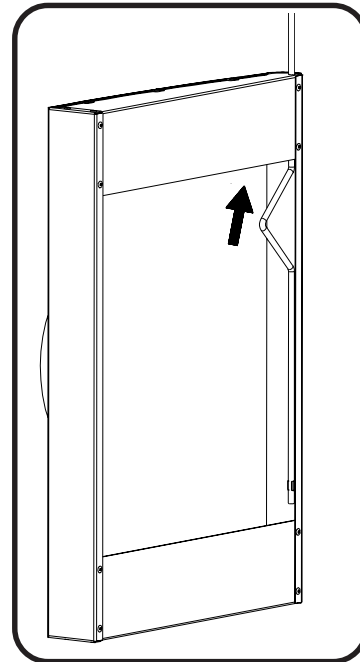
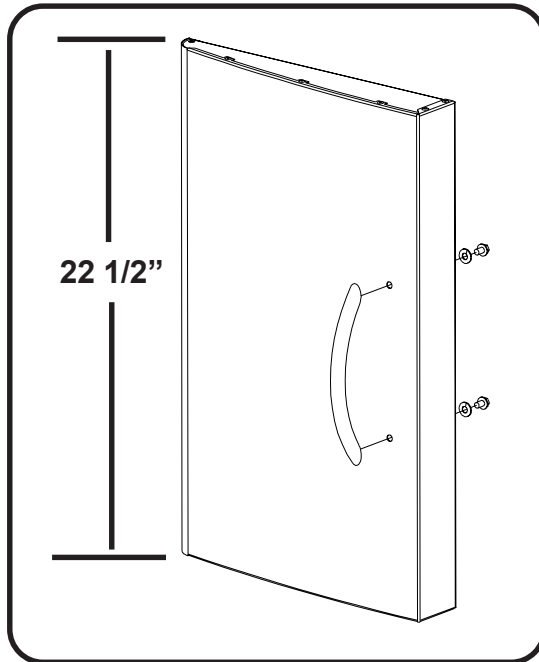

4 x N570-0073
(1/4-20 X 3/8")

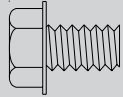

4 X N735-0003
(1/4" LOCK WASHER)

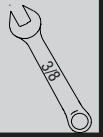

20 Side Enclosure Door Installation

Install door handle onto front of door using (2) 1/4-20 x 3/8" screws and (2) 1/4" lock washers per door.

Insert pivot rod through hole on inside top of door. Holding door in one hand, direct pivot rod into top bushing on the enclosure. Once secure, let rod slide down and through hole in bottom of door and into bushing.

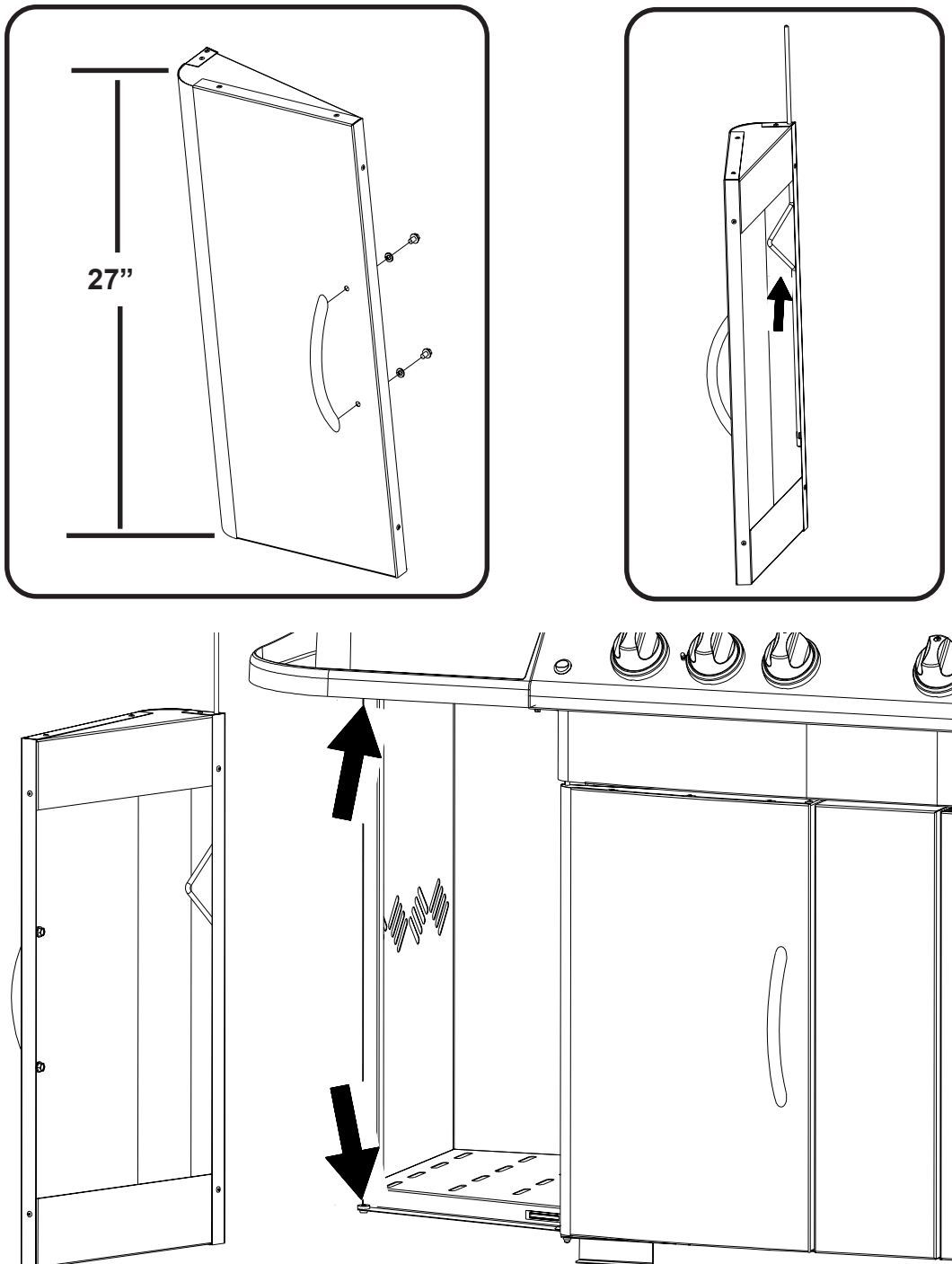

3 X N305-0057
3 X N305-0060
1 X N520-0024

21 Sear Plate, Grid and Warming Rack Installation.

Insert sear plates into base, positioning one over each tube burner with slots down to allow drippings to travel through.

Rest warming rack on brackets inside hood, and insert grids into unit so they sit on back and front lip of base.

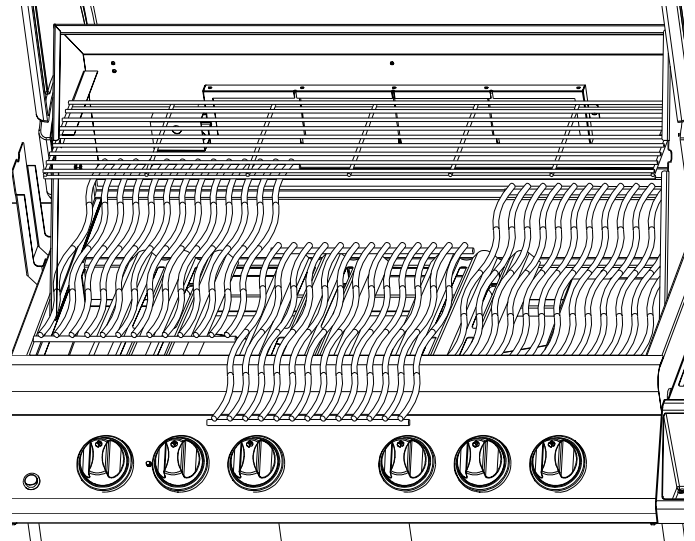
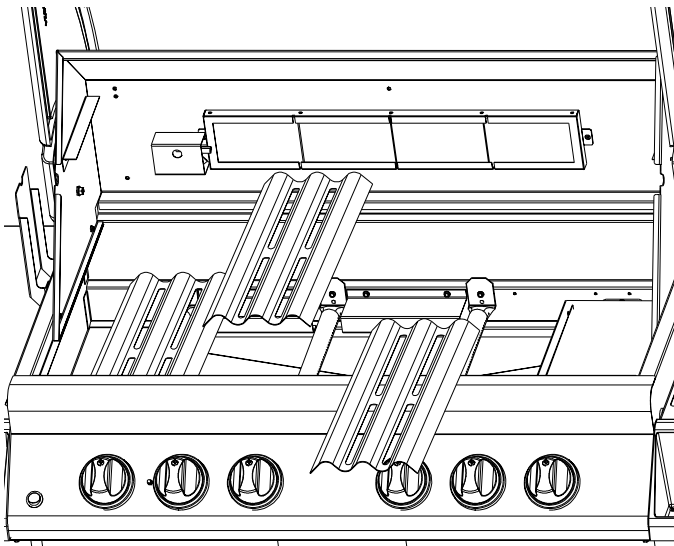

22 Rotisserie Kit Installation

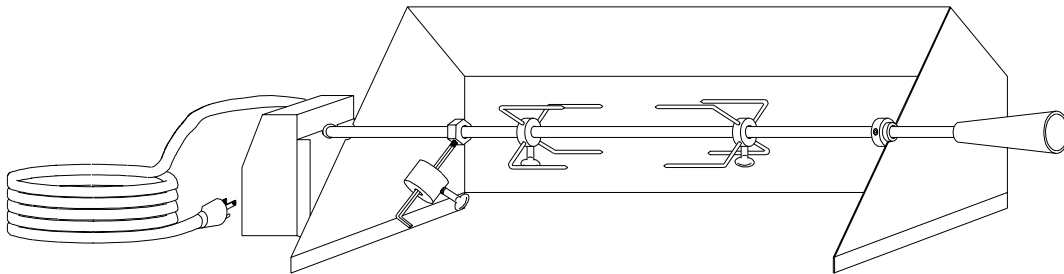

23 Grease Tray and Holder Installation

Clip the wire grease tray holder into the two holes located in the center of the back panel. Place the aluminum grease tray into the grease tray holder.

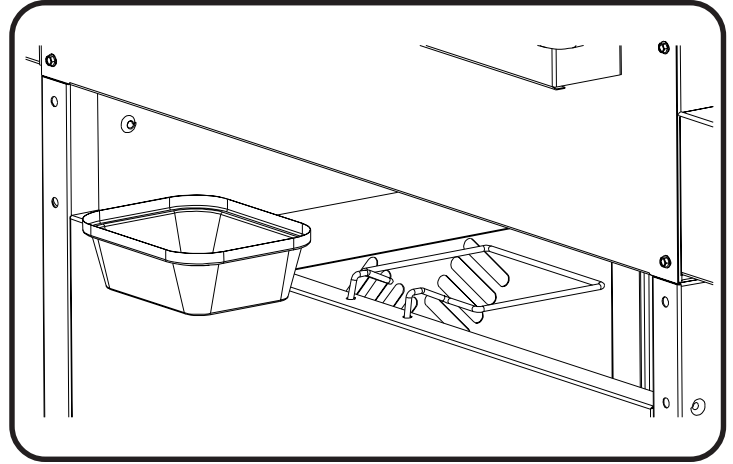
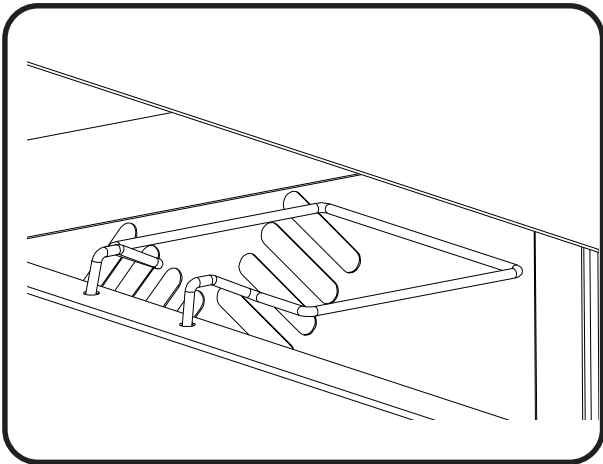

24 Drip Pan Installation

Slide drip pan into rear of base as shown. Ensure drip pan rides along rails on bottom of base.

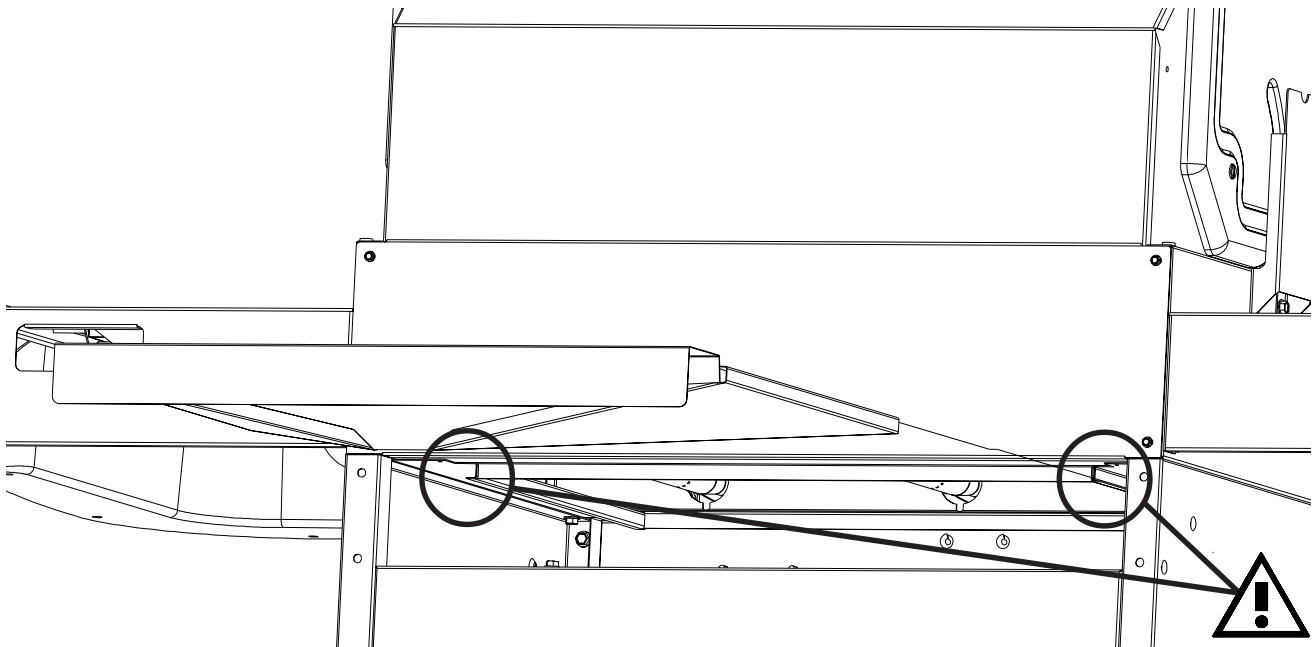



PROPANE ONLY - PROPER HOSE CONNECTION

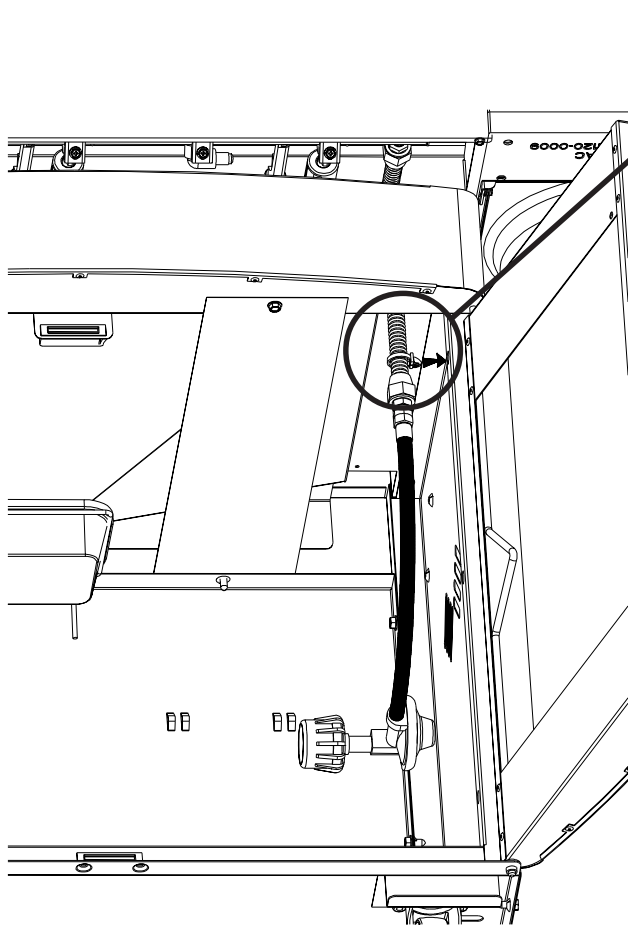

Ensure the regulator drops into the small opening, between the tank heat shield and the right side of the cabinet.

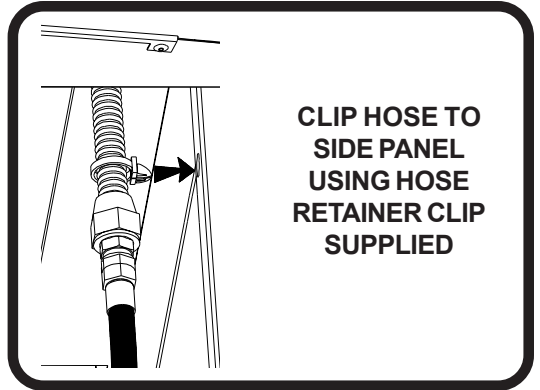

CLIP HOSE TO
SIDE PANEL
USING HOSE
RETAINER CLIP
SUPPLIED

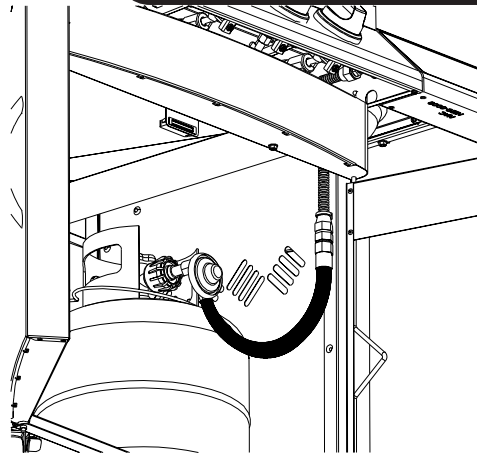

PROPANE ONLY - IMPROPER HOSE CONNECTION

The regulator hose must be attached so that no part of the hose touches the underside of the grill or drippan. A fire will result if these directions are ignored.

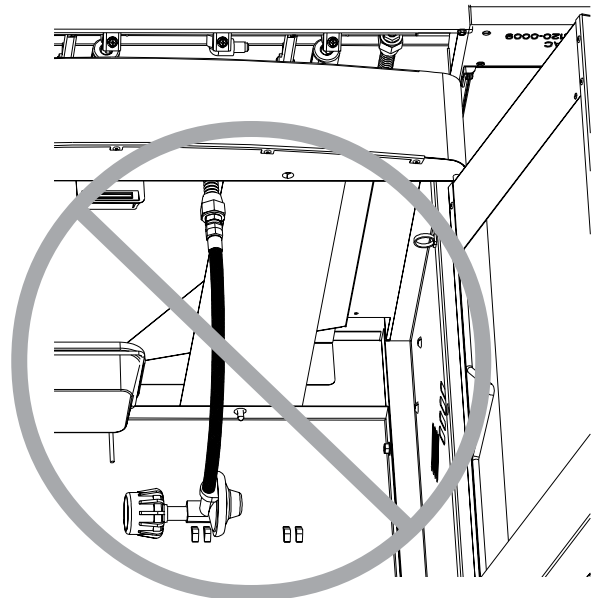

“WARNING - FIRE HAZARD”



NATURAL GAS ONLY - PROPER HOSE CONNECTION

1xN105-0002

2 X

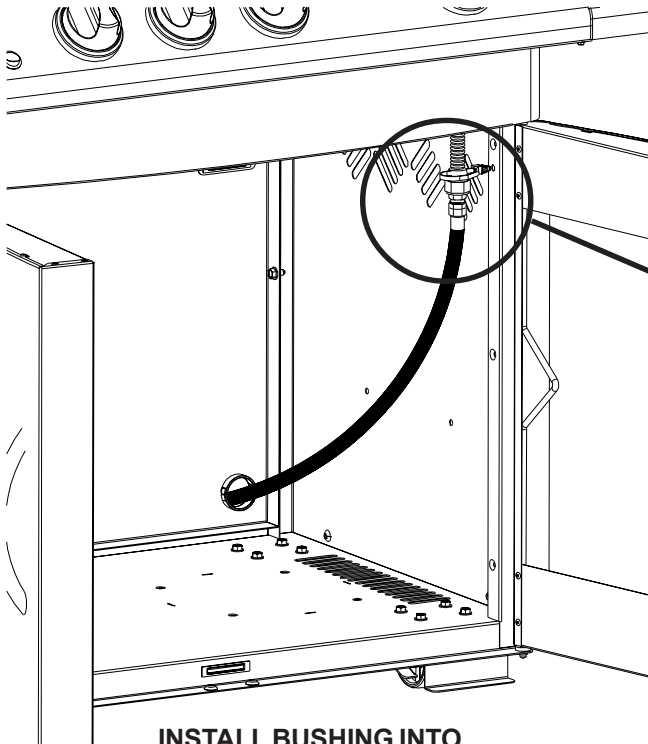

**INSTALL BUSHING INTO
BACK PANEL**

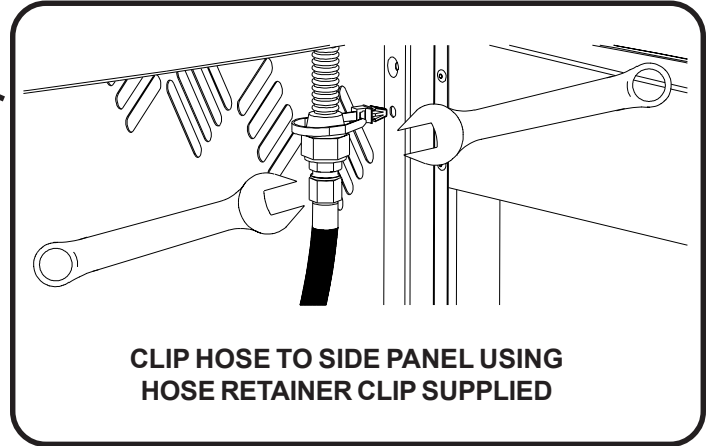

**CLIP HOSE TO SIDE PANEL USING
HOSE RETAINER CLIP SUPPLIED**



**THIS MUST BE PERFORMED BY A LICENSED GAS FITTER.
DO NOT USE PIPE DOPE OR TEFLON TAPE ON THIS CONNECTION**

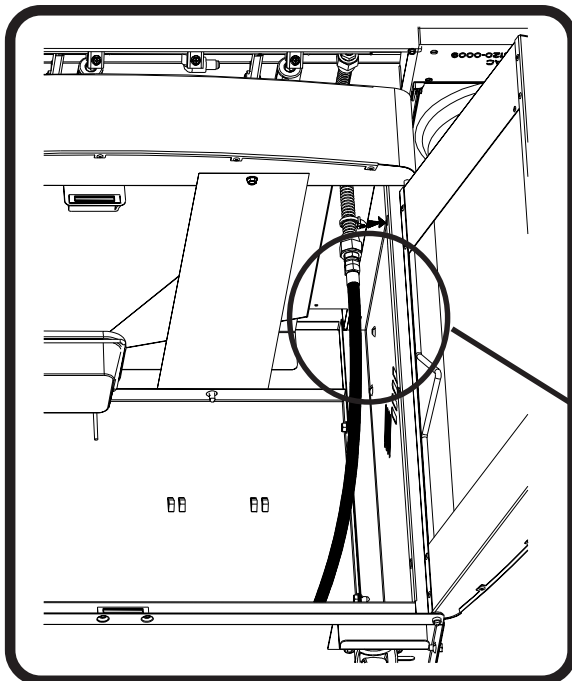



NATURAL GAS ONLY - IMPROPER HOSE CONNECTION



“WARNING - FIRE HAZARD”

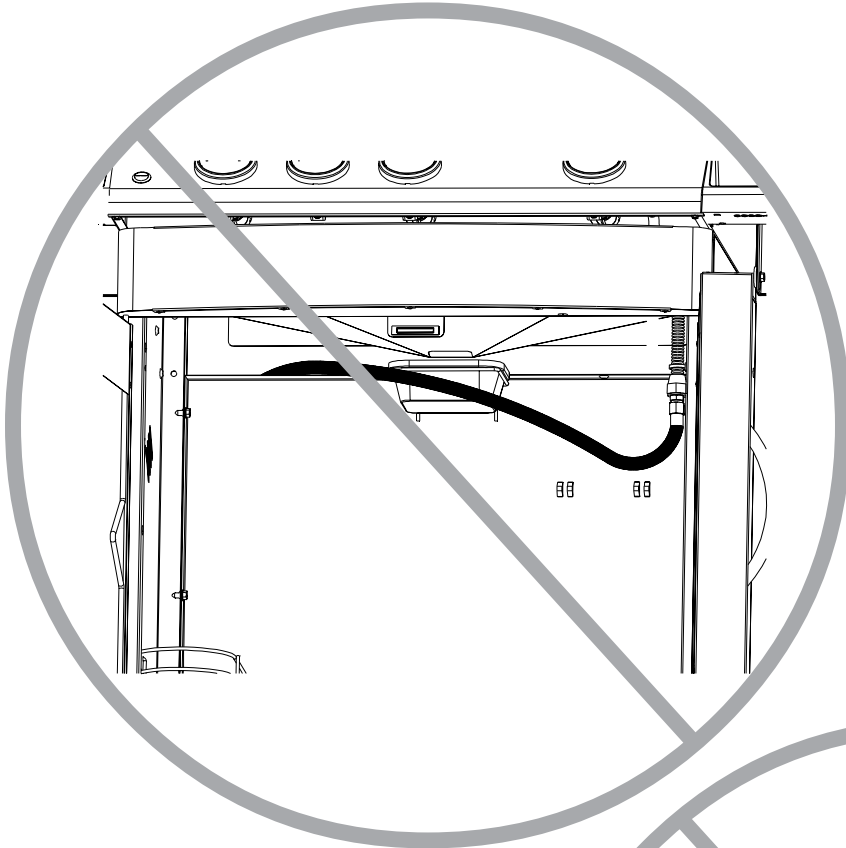

Do not route hose underneath drip pan.

Do not route hose over top of rear panel.

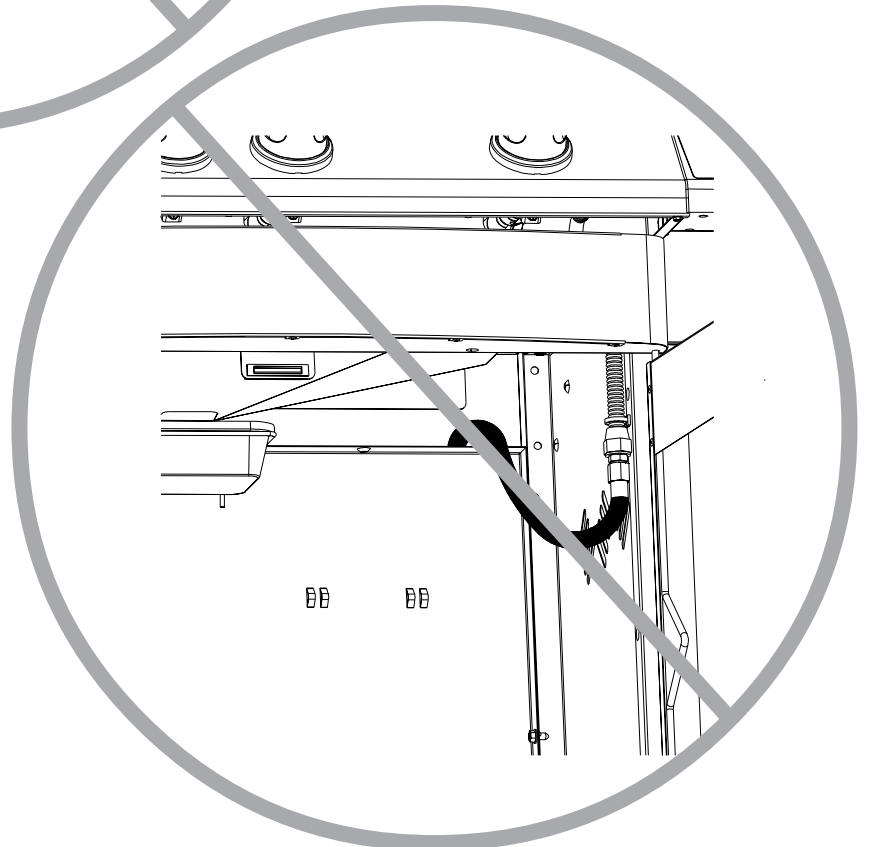

Ensure the hose does not contact any high temperature surfaces, or it may melt and leak causing a fire.

LEAK TESTING INSTRUCTIONS



DANGER

Do not use an open flame to check for gas leaks. Be sure there are no sparks or open flames in the area while you check for leaks. Sparks or open flames will result in a fire or explosion, damage to property, serious bodily injury or death.

LEAK TESTING: This must be done before initial use, annually and whenever any gas components are replaced or serviced. Do not smoke while performing this test, and remove all sources of ignition. See *Leak Testing Diagram* for areas to check.

1. Turn all burner controls to off. Turn supply valve on.
2. Brush a half and half solution of liquid soap and water onto all joints and connections of the regulator, hose, manifolds and valves.
3. Bubbles will indicate a gas leak. Either tighten the loose joint or have the part replaced with one recommended by the customer care department.
4. If the leak cannot be stopped, shut off the gas supply, disconnect it and have the barbecue inspected by your gas supplier or dealer. Do not use the appliance until the leak has been corrected.
5. Turn off gas supply.



A LEAK TEST MUST BE PERFORMED AT THE FOLLOWING TIMES:

- BEFORE INITIAL USE EVEN IF THE GRILL WAS DEALER ASSEMBLED.
- AT LEAST ONCE PER YEAR.
- WHENEVER ANY GAS COMPONENT HAS BEEN REPLACED.

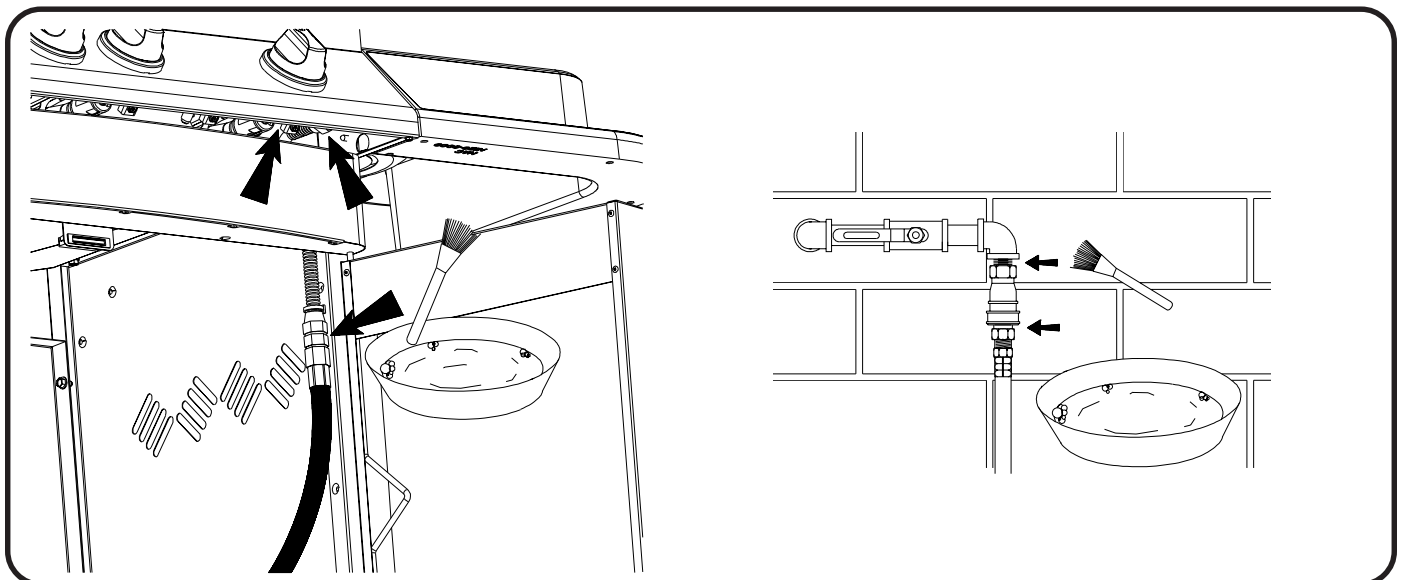
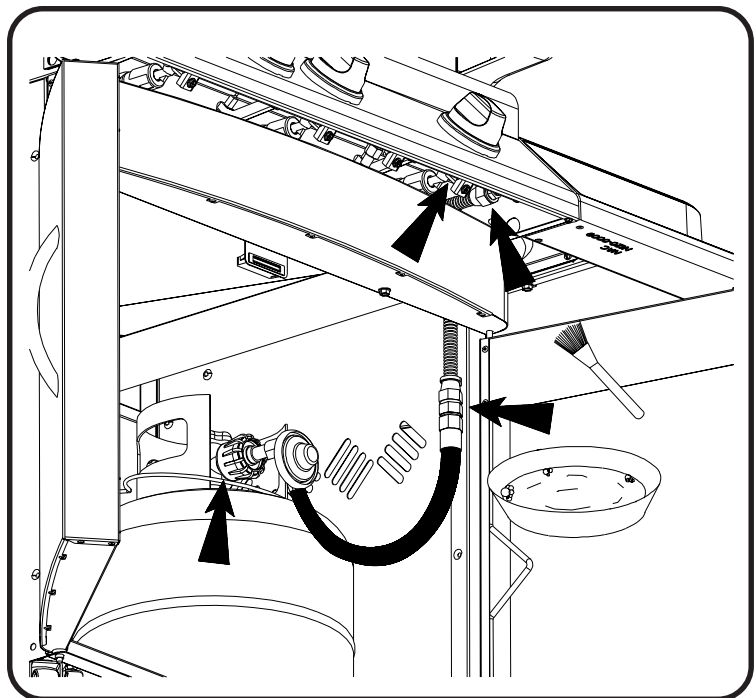

PARTS LIST

Item	Part #	Description	605
1	N135-0024K	left side lid casting	x
2	N385-0129	NAPOLEON logo	x
	W450-0005	logo spring clips	x
3	N570-0082	1/4-20 x 5/8" screw	x
4	N510-0010	black silicone lid bumper	x
5	N685-0003	temperature gauge	x
6	N051-0004	temperature gauge bezel	x
7	N335-0044	stainless steel lid insert	x
8	N585-0042	heat shield lid	x
9	N010-0517	lid handle	x
10	N135-0025K	right side lid casting	x
11	N570-0015	lid pivot screw	x
12	N010-0513	hood assembly	x
13	N570-0008	#8 x 1/2" screw	x
14	N570-0073	1/4-20 x 3/8" screw	x
15	N735-0003	1/4" lockwasher	x
16	N520-0024	warming rack	x
17	N305-0060	cooking grids - stainless rod	x
18	N305-0057	sear plate	x
19	N010-0529	stainless steel side shelf - right	x
20	N120-0009	LUXIDIO side shelf end cap, right	x
21	N570-0080	#14 x 1/2" screw	x
22	N010-0528	stainless steel side shelf - left	x
23	N120-0008	LUXIDIO side shelf end cap, left	x
24	N500-0035K	side burner plate	x
25	N100-0037	side burner	x
26	N335-0043	side burner lid	x
27	N305-0059	side burner grate	x
28	N555-0019	side burner lid pivot rod	x
29	N100-0036	main burner	x
30	N080-0208	main burner cross light bracket	x
31	N475-0199	rotisserie mount	x
32	N010-0509	base	x
33	N010-0512	drip pan	x
34	N160-0014	grease tray holder	x
35	62007	replacement grease trays (5 pieces)	x
36	N200-0079P	back cover	x
37	N475-0187	control panel	x
38	N380-0011	control knob	x
39	N051-0003	control knob bezel	x
40	N530-0003	1-outlet regulator	p
	N345-0001	10ft n/g hose c/w quick disconnect	n
41	N010-0510	manifold assembly c/w valves	p
	N010-0511	manifold assembly c/w valves	n
42	N720-0044	manifold flex connector	x
43	N255-0027	union fitting 3/8" - 3/8"	x
44	N725-0034	main burner valve c/w #56 orifice	p
	N725-0035	main burner valve c/w #52 orifice	n
45	N725-0032	side burner valve	p
	N725-0033	side burner valve	n
	N455-0049	side burner orifice #62	p
	N455-0050	side burner orifice #54	n
	N720-0055	side burner supply tube	x

x - standard
x - compris

p - propane units only
n - natural gas units only
ac - accessory

p - appareils propane seulement
n - appareils gaz naturel seulement
ac - accessoires

PARTS LIST

Item	Part #	Description	605
46	N725-0036	rear burner valve	p
	N725-0037	rear burner valve	n
47	N475-0183P	left / right side panel cabinet enclosure	x
48	N555-0018	door pivot rod	x
49	N010-0506	cart door assembly	x
50	N325-0048	door handle	x
51	N570-0073	door handle screws	x
52	N590-0150P	bottom shelf	x
53	N010-0515	front cabinet support	x
54	N475-0189P	rear cart panel	x
55	N585-0041P	heat shield	p
56	N105-0002	snap bushing	x
57	N105-0011	door bushings	x
58	N655-0094P	tank ring support	p
59	N430-0002	magnetic catch	x
	N020-0123	main assembly baggie	x
60	N080-0210	top magnet bracket	x
61	N750-0021	wiring harness led	x
62	N190-0001	battery pack	x
	W043-0002	battery "AA"	x
64	N735-0001	insulated washer	x
	N105-0001	bushing 7/8"	x
66	N640-0001	hose retainer clip	x
67	N160-0015	propane tank clip	p
68	N130-0012	revolving caster	x
69	N450-0027	locking nut 1/4-20	x
70	N010-0499	infra red main burner	x
71	N080-0207	support bracket infra red burner	x
72	N010-0527N	infra red rear burner	n
	N010-0527P	infra red rear burner	p
	N455-0052	rear burner orifice #51	n
	N455-0051	rear burner orifice #1.15mm	p
	N720-0053	rear burner supply tube	x
74	N240-0024	rear burner electrode c/w pilot	x
75	N080-0206	rear burner electrode cover	x
	N570-0079	rear burner electrode cover screw	x
	N615-0011	rear burner electrode cover spacer	x
76	N200-0080	infra red rear burner cover	x
77	N475-0200	front cabinet fascia	x
78	N475-0191P	left/right side panel side enclosure	x
79	N475-0192P	top/bottom panel side enclosure "A"	x
80	N475-0198P	top/bottom panel side enclosure "B"	x
81	N010-0516	enclosure door assembly	x
82	N555-0023	pivot rod door enclosure	x
83	N080-0212	stabilizer brackets	x
84	N590-0164	condiment basket	x
85	N555-0027	tank inhibitor rod	p
86	N130-0013	non revolving caster	x
	N370-0454	rotisserie kit	x
	N555-0021	rotisserie spit	x
	63605	vinyl cover	ac
	56017	stainless steel griddle	ac
	67730	charcoal tray	ac

x - standard
x - compris

p - propane units only
n - natural gas units only
ac - accessory

p - appareils propane seulement
n - appareils gaz naturel seulement
ac - accessoires

