

SERIAL / SÉRIE# _____

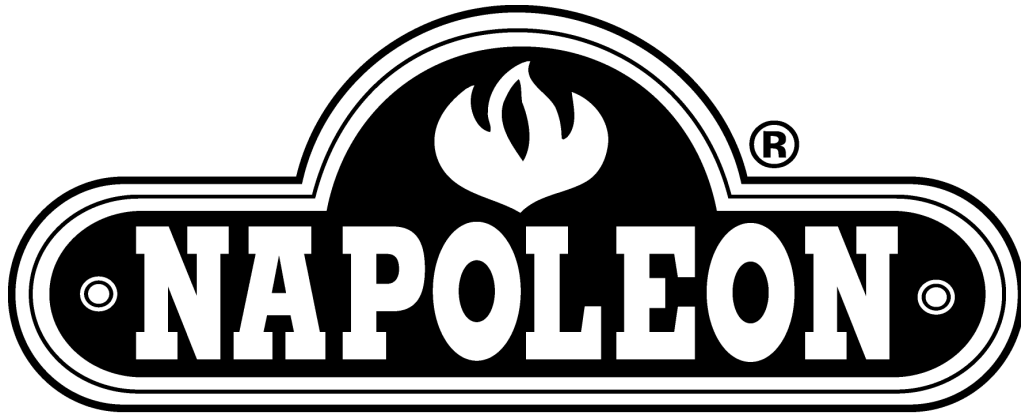

GOURMET GRILLS

Award Winning Products

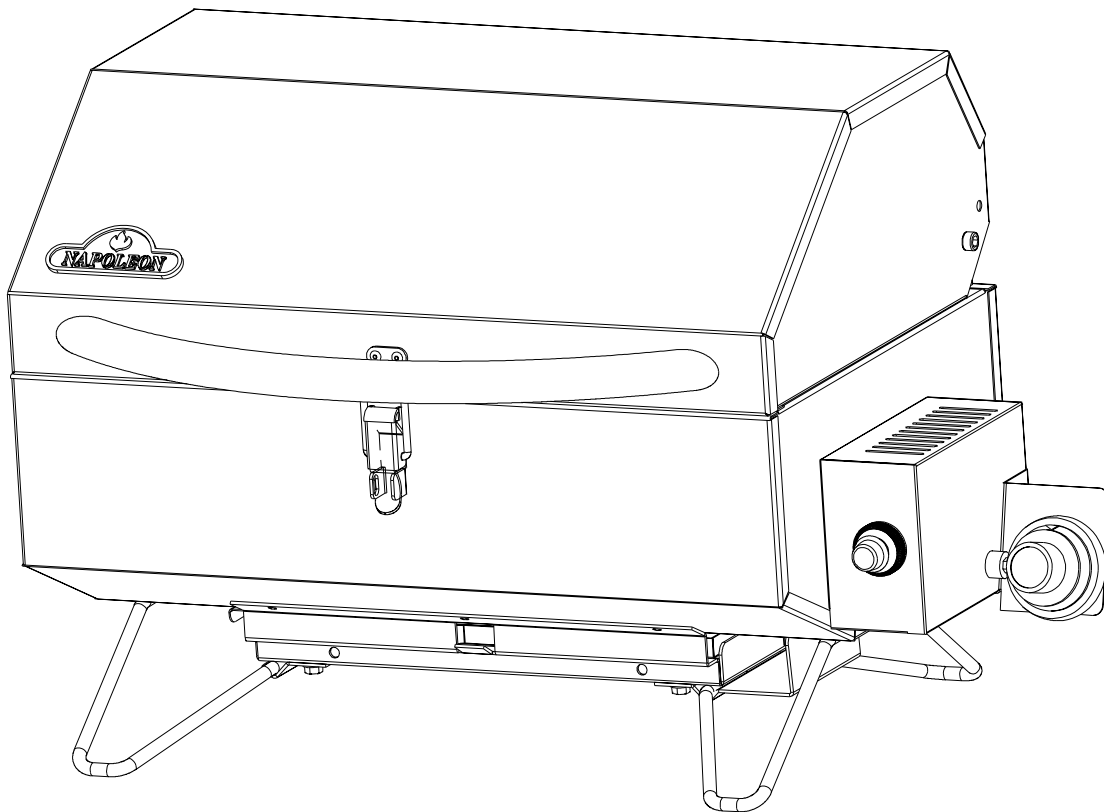

PTSS215



NAPOLEON APPLIANCE CORP., 214 BAYVIEW DR., BARRIE,
ONTARIO, CANADA L4N 4Y8 (705)726-4278, FAX (705)725-2564
EMAIL/COURRIEL: care@nac.on.ca WEB SITE/SITE WEB: www.napoleongrills.com



RETAIN THIS MANUAL FOR FUTURE REFERENCE
VEUILLEZ CONSERVER CE MANUEL POUR CONSULTATION ULTÉRIEURE

N415-0110/JAN22/07



The PTSS215 has been designed with mobility in mind. With collapsable legs, the PTSS215 can be set up on any flat surface. The legs fold out and lock into place, folding back into a locked position when on the go or used with any of our mounting options (see illustrated diagrams on mounting options and accessories).

All NAPOLEON gas grills are manufactured under the strict Standard of the world recognized ISO 9001-2000 Quality Assurance Certificate.

NAPOLEON products are designed with superior components and materials, and are assembled by trained craftsmen who take great pride in their work. The burner and valve assembly are leaktested and test-fired at a quality test station, and thoroughly inspected by a qualified technician before packaging and shipping to ensure that you, the customer, receive the quality product you expect from NAPOLEON.



NAPOLEON GAS GRILL PRESIDENT'S LIMITED LIFETIME WARRANTY

NAPOLEON warrants the following materials and workmanship in your new NAPOLEON gas grill against defects for as long as you own the gas grill. This covers: stainless steel housings, stainless steel burners, stainless steel rod cooking grids, and stainless steel lids. Subject to the following conditions. During the first ten years NAPOLEON will provide replacement parts at our option free of charge. From the eleventh year to lifetime NAPOLEON will provide replacement parts at 50% of the current retail price.

Components such as stainless steel sear plates, ceramic infra-red burners (excluding screens), and igniter (excluding batteries) are covered and NAPOLEON will provide parts free of charge during the first three years of the limited warranty.

Components such as regulator, warming rack, hoses and connectors, fasteners and accessories are covered and NAPOLEON will provide parts free of charge during the first year of the limited warranty.

NAPOLEON shall not be liable for any transportation charges, labour costs or export duties.

CONDITIONS AND LIMITATIONS

"NAPOLEON warrants its products against manufacturing defects to the original purchaser only (ie., the individual or legal entity (registered customer) whose name appears on the warranty registration card filed with NAPOLEON), provided that the purchase was made through an authorized NAPOLEON dealer and is subject to the following conditions and limitations:"

This factory warranty is non-transferable and may not be extended what-so-ever by any of our representatives.

The gas grill must be installed by a licenced, authorized service technician or contractor. Installation must be done in accordance with the installation instructions included with the product and all local and national building and fire codes.

This limited warranty does not cover damages caused by misuse, lack of maintenance, grease fires, hostile environments, accident, alterations, abuse or neglect and parts installed from other manufacturers will nullify this warranty.

This limited warranty further does not cover any scratches, dents, painted finishes, corrosion or discolouring by heat, abrasive and chemical cleaners, nor chipping on porcelain enamel parts, nor any components used in the installation of the gas grill.

Should deterioration of parts occur to the degree of non-performance within the duration of the warranted coverage, a replacement part will be provided.

In the first year only, this warranty extends to the replacement of warranted parts which are defective in material or workmanship provided that the product has been operated in accordance with the operation instructions and under normal conditions.

After the first year, with respect to this President's Limited Lifetime Warranty NAPOLEON may, at its discretion, fully discharge all obligations with respect to this warranty by refunding to the original warranted purchaser the wholesale price of any warranted but defective part(s).

NAPOLEON will not be responsible for the installation, labour or any other costs or expenses related to the re-installation of a warranted part, and such expenses are not covered by this warranty.

Notwithstanding any provision contained in this President's Limited Lifetime Warranty NAPOLEON's responsibility under this warranty is defined as above and it shall not in any event extend to any incidental, consequential, or indirect damages.

This warranty defines the obligation and liability of NAPOLEON with respect to the NAPOLEON gas grill and any other warranties expressed or implied with respect to this product, its components or accessories are excluded.

NAPOLEON neither assumes, nor authorizes any third party to assume, on its behalf, any other liabilities with respect to the sale of this product. NAPOLEON will not be responsible for: over firing, blow outs caused by environmental conditions such as strong winds, or inadequate ventilation,

Any damages to the gas grill due to weather damage, hail, rough handling, damaging chemicals or cleaners will not be the responsibility of NAPOLEON.

The bill of sale or copy will be required together with a serial number and a model number when making any warranty claims from NAPOLEON. The warranty registration card must be returned within fourteen days to register the warranty or you can register on-line at www.napoleongrills.com.

NAPOLEON reserves the right to have its representative inspect any product or part prior to honouring any warranty claim.

NAPOLEON shall not be liable for any transportation charges, labour costs, or export duties.

WARNING

Do not try to light this appliance without reading "LIGHTING" instructions section of this manual.

FOR YOUR SAFETY DO NOT STORE OR USE GASOLINE OR OTHER FLAMMABLE VAPOURS AND LIQUIDS IN THE VICINITY OF THIS OR ANY OTHER APPLIANCE. AN LP CYLINDER NOT CONNECTED FOR USE MUST NOT BE STORED IN THE VICINITY OF THIS OR ANY OTHER APPLIANCE. IF THE INFORMATION IN THESE INSTRUCTIONS IS NOT FOLLOWED EXACTLY, A FIRE OR EXPLOSION MAY RESULT, CAUSING PROPERTY DAMAGE, PERSONAL INJURY OR DEATH.

WHAT TO DO IF YOU SMELL GAS:

- Turn off main gas supply.
- Extinguish any open flame.
- Open lid.
- Immediately call your gas supplier, or your fire department if odour continues.

SAFE OPERATING PRACTICES

- This gas grill must only be used outdoors in a well-ventilated space and must not be used inside a building, garage or any other enclosed area.
- Keep any electrical supply cord and fuel supply hose away from any heated surfaces.
- Inspect the fuel supply hose before each use. If there is evidence of excessive abrasion or wear or the hose is cut, it must be replaced, prior to using the gas grill, with a replacement hose assembly specified by the manufacturer.
- When the propane cylinder is not disconnected from the appliance, the gas grill and cylinder must be stored outdoors in a well ventilated space.
- Do not locate in windy settings. High winds adversely affect the cooking performance of the gas grill.
- This gas grill is designed for L.P. only.
- Under no circumstances should this gas grill be modified.
- Gas must be turned off at the propane cylinder when the gas grill is
- Adults and especially children should be alerted to the hazards of high surface temperatures. Young children should be supervised near the gas grill.
- When the gas grill is to be stored indoors, the connection between the propane cylinder and the gas grill must be disconnected and the cylinder removed and stored outdoors in a well ventilated space out of reach of children. Disconnected cylinders must not be stored in a building, garage or any other enclosed area.
- This gas grill is designed for outdoor use only.
- Due to the intense heat generated by the infrared burner system, cooking, pre-heating and lighting your grill must only be done with the lid open. If these instructions are ignored there is a risk of flash back (a fire within the burner tube). Damage caused by failure to follow these instructions is not covered by your grill warranty.
- The lid may only be closed when the grill is not in use.

CAUTION

During unpacking and assembly it is recommended that you wear work gloves and safety glasses for your protection. Although we make every effort to make the assembly process as problem free and safe as possible, it is characteristic of fabricated steel parts that the edges and corners may be sharp and can cause cuts if handled incorrectly.

GENERAL INFORMATION

This gas barbecue is certified under Canadian and American national standards, CSA 1.8 - 2002 and ANSI Z83.11 - 2002 respectively for outdoor gas grills, with references to ANSI Z21.57 - 2001, CSA 1.16 M79 (r1996), NFPA 302, CFR title 33, ANSI Z21.89 - 2002, ANSI Z21.72b - 2002, and CSA 11.2b - 2002 and should be installed to conform with local codes. In absence of local codes, install to the current National Fuel Gas Code CAN/CGA-B149.1 or ANSI Z223.1/NFPA 54, natural gas and propane installation code.

Use only the pressure regulator provided with this barbecue. Replacement pressure regulators must be supplied by or specified by the manufacturer. The regulator supplies a pressure of 22 inches water column to the gas grill and has a female CGA#600 type fitting. **To install the regulator, screw it into the threaded hole on the right side of the grill. Tube burners may have to be pushed upwards slightly from underneath to ensure that the orifice is aligned with the opening in the burner.** 1 lb disposable cylinders to be used with this unit must be equipped with a male CGA #600 type connection. This cylinder has a positive seating connection, which will not allow gas flow until a positive seal has been achieved. **To install the cylinder simply screw it into the regulator - tighten hand tight.**

OPTIONAL SUPPLY HOSE INSTRUCTIONS: An optional hose is available from your Napoleon Dealer that allows the grill to be connected to a 20 lb (9.1 kg) cylinder. A dented or rusted cylinder may be hazardous and should be checked by your propane supplier. Never use a cylinder with a damaged valve. Use only a propane supply cylinder constructed and marked in accordance with the specifications for LP-gas cylinders of the Canadian Transport Commission (CTC) or the US Department of Transportation (DOT). The propane cylinder must be provided with a shut-off valve terminating in a propane cylinder valve type QCC1, and a safety relief device having direct communication with the vapour space of the cylinder. The cylinder supply system must be arranged for vapour withdrawal and the cylinder shall include a collar to protect the cylinder valve. The cylinder shall incorporate a listed OPD (overfill protection device). **To use the hose, connect it (note the the connection to the 20 lb cylinder is a left hand thread) between the tank valve and the regulator on the grill. These connections should be tightened hand tight, and leak tested when performing a leak test. Ensure that the cylinder valve is turned off whenever the grill is not in use.**

CALIFORNIA PROPOSITION 65: The burning of gas fuel creates byproducts, some of which are on the list as substances known by the State of California to cause cancer or reproductive harm. When cooking with gas, always ensure adequate ventilation to the unit, to minimize exposure to such substances.

IMPORTANT DO'S AND DON'TS

DO'S

- Read the entire instruction manual before operating the gas grill.
- Maintain proper clearance to combustibles (6" to rear of unit, 4" to sides). Additional clearance is recommended near vinyl siding or large panes of glass.
- Leak test the unit before initial use, annually and whenever any gas components are replaced.
- Follow lighting instructions carefully when operating grill.
- Ensure sear plate is positioned properly. The holes must be towards the right side of the gas grill.
- Clean grease tray and sear plates regularly to avoid build-up which may lead to grease fires.
- Inspect infra-red burner venturi tubes for spider webs and other obstructions periodically. Clean the tubes completely if you find any such obstructions.
- If installed on a boat or R.V. supplied with a regulated propane source, the fuel line must be tee'd off prior to the pressure regulator of the boat or R.V.

DON'TS

- Do not route hose (optional) underneath drip pan - proper hose clearance to bottom of unit must be maintained.
- Do not locate unit under unprotected combustible construction.
- Do not leave grill unattended when operating.
- Do not light burners with lid closed.
- Do not move grill when hot or operating.
- Do not allow cold water (rain, sprinkler, hose, etc.) to come in contact with ceramic burners. A large temperature differential can cause cracking in the ceramic tile.
- Do not clean the ceramic tile with a wire brush. If debris is collecting on your burner, simply light the burner and operate on high for 5 minutes with the lid open, allowing debris to burn off.
- Do not use water, beer, or any other liquids to control flare-ups.
- Do not pinch electrode lead between bottom surface of grill and folding leg.
- Do not use a pressure washer to clean any part of the unit.

HANDLE WITH CARE

Use care when handling or transporting your grill to prevent damage and misalignment of internal components. Although this grill has been designed with mobility in mind, rough handling or abuse will result in damage to internal components, preventing your grill from operating properly.

LEAK TESTING INSTRUCTIONS



DO NOT USE A FLAME TO LEAK TEST.

LEAK TESTING: This must be done before initial use, annually and whenever any gas components are replaced or serviced. No smoking while performing this test, and remove all sources of ignition. See *Leak Testing Diagram* for areas to check.

1. Connect the 1 lb cylinder to the grill regulator, or if using the optional supply hose, connect it between the cylinder valve and the grill regulator. Ensure the grill regulator is in the "LOCK OFF" position, turn the cylinder valve on.
2. Brush a half and half solution of liquid soap and water onto the joint between the regulator and the 1 lb cylinder. When using the optional supply hose, brush the solution onto the connections at each end of the hose.
3. Bubbles will indicate a gas leak. Either tighten the loose joint or replace the part with one recommended by the dealer.
4. If the leak cannot be stopped, disconnect the 1 lb cylinder, or shut off the cylinder valve on the 20 lb cylinder, disconnect it and have the barbecue inspected by your gas supplier or dealer. Do not use the appliance until the leak has been corrected.
5. Turn off gas supply.

LIGHTING INSTRUCTIONS

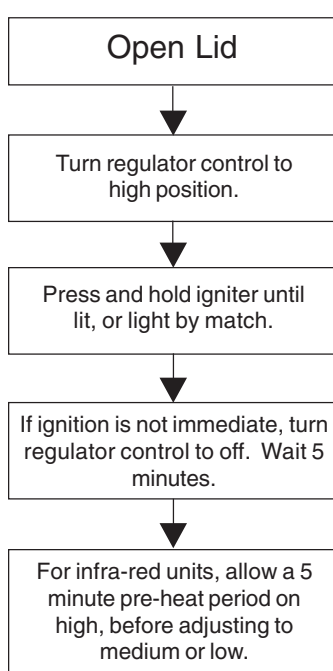

LIGHTING PORT HOLE

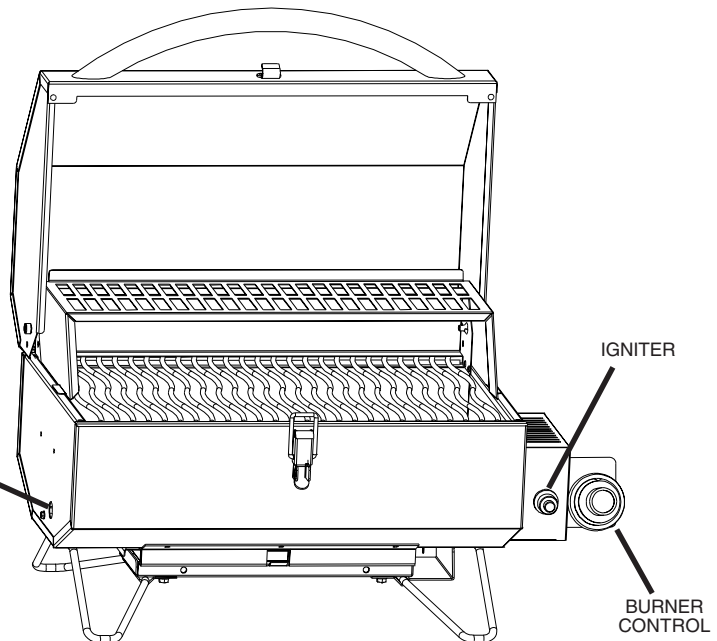

Do not operate the infra-red burner with the lid closed.

INFRA-RED HEAT

Most people don't realize that the heat source that we are most familiar with, namely the sun, warms the earth using mainly infra-red energy. Infra-red energy is a form of electro-magnetic energy that has a wavelength just greater than the red end of the visible light spectrum, but less than that of radio waves. This energy was discovered in 1800 by Sir William Herschel who, dispersed sunlight into its component colours using a prism. He showed that most of the heat in the beam fell into the spectral region just beyond the red end of the spectrum, where no visible light existed. This is infra-red energy. Most materials readily absorb infra-red radiation in a wide range of wavelengths, causing an increase in temperatures of the materials. This is the same phenomenon that causes us to feel warmth when we are exposed to sunlight. The infra-red rays from the sun travel through the vacuum of space, through the atmosphere and penetrate our skin. This causes increased molecular activity in the skin, which creates internal friction and generates heat, allowing us to feel warmth.

Foods cooked over infra-red heat sources are heated by the same principle. Charcoal is the traditional way of infra-red cooking that we are all familiar with. The glowing briquettes emit infra-red energy to the food being cooked, with very little drying effect. Any juices or oils that escape from the food drip down onto the charcoal and vaporize into smoke giving the food its delicious grilled taste. The Napoleon infra-red burner cooks in the same way. In each burner, 10000 ports each with its own tiny flame cause the surface of the ceramic to glow red. This glow emits the same type of infra-red heat to the food, without the hassle or mess of charcoal. It also provides a more consistent heated area that is far easier to regulate than a charcoal fire. For instantaneous searing the burners can be set to high, yet they can also be turned down for slower cooking. We all know how difficult that is on a charcoal fire. Traditional gas burners heat the food in a different way. The air surrounding the burner is heated by the combustion process and then rises up to the food being cooked. This generates lower grill temperatures that are ideal for more delicate cuisine such as seafood or vegetables. The bottom line is that Napoleon's infra-red burners produce searing heat for juicier, tastier steaks, hamburgers and other meats. For cooking times and tips refer to the Infra-red Grilling Chart.

COOKING INSTRUCTIONS

When lit for the first time, the gas grill will emit a slight odour. This is a normal temporary condition caused by the "burn-in" of internal paints and lubricants used in the manufacturing process and will not occur again. Simply run the main burners on high with the lid open for approximately ½ hour. When cooking very lean meats, such as chicken breasts, or lean pork, the grids can be oiled before pre-heating to reduce sticking. Cooking meat with a high degree of fat content, may create flare-ups. Either trim some fat or reduce temperatures to prevent this. Should a flare-up occur, move food away from flames, reduce heat. Leave the lid open. See 'Your All Season Grill' cookbook by Napoleon for more detailed instructions.

INFRA-RED MAIN BURNER USE:

1. Follow the infra-red burner ignition procedures and operate on high for 5 minutes or until the ceramic burners glow red.
2. Place food on grills and cook according to times listed in the Infra-Red Grilling Chart.
3. Depending upon your taste, continue cooking over infra-red burners on high, medium or low, turning food frequently, or place food away from infra-red burners, and allow oven temperature to slowly finish cooking your food.

Caution: Due to the intense heat the infra-red burners provide, food left unattended over burners will burn quickly. Keep the lid open when cooking with the infra-red burners on high. The intense heat ensures adequate searing temperatures even with the lid open. This also allows observation of the food, so as to prevent burning.

CONVENTIONAL MAIN BURNER USE: The lower temperatures that these burners provide make them ideal for cooking seafood, vegetables and other delicate cuisine. These burners can be used for searing, but the infra-red burners are better suited for this type of cooking. Food cooked for a short period of time (fish, vegetables) may be grilled with the lid open. Cooking with the lid closed will ensure higher, more even temperatures that will reduce cooking time and cook meat more evenly. Food that has a cooking time longer than 30 minutes, such as roasts, may be cooked indirectly. Follow the tube burner lighting instructions and operate on high for 5 to 10 minutes with the lid closed to preheat the grill.

INFRA-RED GRILLING CHART

FOOD	CONTROL SETTING	COOKING TIME	HELPFUL SUGGESTIONS
Steak 1" Thick	High setting 2 min. each side	4 min. - Rare	When selecting meat for grilling, ask for meat with a marbled fat distribution. The fat acts as a natural tenderizer while cooking and will keep the meat moist and juicy.
	High setting 2 min. each side then medium setting	6 min. - Medium	
	High setting 2 min. each side then medium setting	8 min. - Well Done	
Hamburger 1/2" Thick	High setting 2 min. each side	4 min. - Rare	Preparing hamburgers to order is made easier by varying the thickness of your patties. To add an exotic taste to your meat, try adding hickory-flavored woodchips into Napoleon's woodchip smoker.
	High setting 2 1/2 min. each side	5 min. - Medium	
	High setting 3 min. each side	6 min. - Well Done	
Chicken Pieces	High setting 2 min. each side medium-low to low setting	20-25 min.	The joint connecting the thigh and the leg from the skinless side, should be sliced 3/4 of the way though in order for the meat to lay flatter on the grill. This will help it to cook faster and more evenly. To add a trademark taste to your cooking, try adding mesquite-flavoured woodchips in your Napoleon woodchip smoker.
Pork Chops	Medium	6 min. per side	Trim off the excess fat before grilling. Choose thicker chops to get more tender meat.
Spare Ribs	High setting for 5 minutes low to finish	20 min. per side turn often	Choose ribs that are lean and meaty. Grill until meat easily pulls away from the bone.
Lamb Chops	High setting for 5 minutes medium to finish	15 min. per side	Trim off the excess fat before grilling. Choose extra thick chops to get more tender meat.
Hot Dogs	Medium - Low	4-6 min.	Select the larger size wieners. Slit the skin lengthwise before grilling.

CLEANING INSTRUCTIONS

Ensure that the burners are turned off prior to cleaning. Avoid unprotected contact with hot surfaces. Clean grill in an area where cleaning solutions will not harm decks, lawns or patios. Do not use oven cleaner to clean any part of this gas grill. Do not use a self cleaning oven to clean cooking grids or any other parts of the gas grill. Barbecue sauce and salt can be corrosive and will cause rapid deterioration of the gas grill components unless cleaned regularly.

GRIDS AND WARMING RACK - The grids and warming rack are best cleaned during the pre-heat period with a soft brass wire brush. Steel wool can be used for stubborn stains. Stainless grids will discolour permanently from normal usage, due to the high temperature of the cooking surface.

CLEANING INSIDE THE GAS GRILL - Remove the cooking grid. Use a soft brass wire brush to clean loose debris from the insides of the lid. Scrape sear plate with a putty knife or scraper, and use a wire brush to remove ash. Remove the sear plate and brush debris off of the burner with a brass wire brush. Brush all debris from inside the gas grill into the removable drip pan. Ensure that the sear plate is placed properly when reinstalled (holes towards the right end of the grill), or whenever the grill is packed away for transport.

DRIP PAN - Slide the drip pan out for easy cleaning. It should be cleaned frequently (every 4-5 uses) to avoid grease buildup. Grease and excess drippings accumulate in the drip pan located under the grill. Accumulated grease can cause a fire hazard. Do not line the drip pan with aluminum foil, as it can prevent the proper amount of air needed for burner to operate. The pan should be scraped out with a putty knife or scraper.

CLEANING THE OUTSIDE OF THE GAS GRILL - Do not use abrasive cleaners to clean stainless steel parts. To clean stainless surfaces, use a stainless steel cleaner or a non-abrasive cleaner. Always wipe in the direction of the grain. Do not use steel wool, as it will scratch the finish and leave small particles of ferrous metal which can promote rusting. Stainless steel parts will discolour when heated, usually to a golden or brown colour. This discolouration is normal and will not affect the performance of the grill.

INFRA-RED BURNERS - Because of the high intensity of the infra-red burner, most drippings and food particles that fall onto the burner surface are immediately incinerated. However, some debris and residue may remain. To remove this residue after cooking, operate the grill on high for 5-10 minutes with the lid open.

MAINTENANCE INSTRUCTIONS

It is recommended that this gas grill be thoroughly inspected and serviced annually by a qualified service person.

Turn off the gas at the source and disconnect unit before servicing. Maintenance should only be done when the grill is cool, to avoid the possibility of burns. A leak test must be performed annually, and whenever any component of the gas train is replaced.

COMBUSTION AIR ADJUSTMENT - (This must be done by a qualified gas installer.) The air shutter is factory set and should not have to be adjusted under normal conditions. However, some extreme field conditions may exist that require adjustment. When the air shutter is adjusted correctly, the flames will be dark blue with light blue tips, and occasional yellow tips.

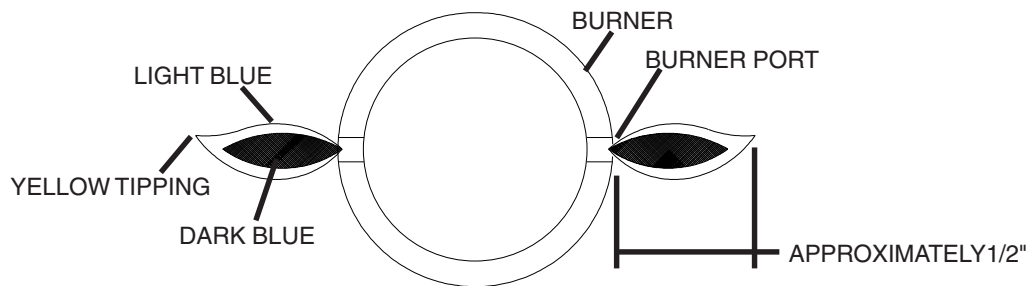

If the burner is getting too little air, the flames will be lazy yellow, and possibly produce soot. If the burner is getting too much air, the flames will be lifting erratically from the burner and may cause difficulties when lighting.

1. Loosen air-shutter lock screw, located under the regulator/igniter mount, and open or close air shutter as required. The normal setting for the tube burner is 1/8".
2. Light burner and set to high. Visually inspect burner flames. When shutters are set, turn regulator off, tighten locking screw. Be sure the air shutter does not move when tightening the screw.
3. Infra-red burners have no air adjustment.

TUBE BURNERS - The burner is made from 304 stainless steel, but due to the extreme heat and corrosive environment, surface corrosion will occur. Use a brass wire brush to remove surface corrosion. Clean any blocked ports using an opened paper clip. Do not enlarge the burner ports. Spiders and insects are attracted to the smell of propane and natural gas. The burner is equipped with an insect screen in the air shutter, which will reduce the likelihood of insects building nests inside the burner, but does not entirely eliminate the problem. The nest or web will cause the burner to burn with a soft yellow or orange flame or cause a fire (flashback) at the air shutter underneath the regulator mount. To clean the inside of the burner, it must be removed from the gas grill. Remove the cooking grid and sear plate. Remove the screw that attaches the burner to the side wall. Remove the regulator. Slide the burner to the front and upwards to remove. Use a flexible venturi tube cleaning brush to clean out the inside of the burner. Shake any loose debris out of the burner, through the gas inlet. Ensure that none of the burner ports are blocked. Use an opened paperclip to clean any blocked ports. Ensure that the insect screen is clean, and free of any lint or other debris. Check also that the valve orifice is clean. Do not enlarge the orifice. Re-install the burner in the reverse procedure. Check that the regulator orifice enters the burner when installing. Replace sear plate and tighten screw to complete installation.

PROTECTION OF INFRA-RED BURNERS - The infra-red burners of your grill are designed to provide a long service life. However, there are steps you must take to prevent cracking of their ceramic surfaces, which will cause the burners to malfunction. Following are the common causes of cracks and the steps you must take to avoid them. Damage caused by failure to follow these steps is not covered by your grill warranty.

1. **Impact with Hard Objects** - Never allow hard objects to strike the ceramic. Take care when inserting or removing cooking grates and accessories into or from the grill. If these objects were to fall on the ceramic, it is likely to crack.
2. **Water or Other Liquids** - Cold liquid contacting a hot surface in substantial amounts can cause the surface to break. Do not throw water into the grill to douse a flame. Also if the ceramic or interior of a burner becomes wet while not in use, later operation of the burner can create steam, which may produce enough pressure to crack the ceramic. In addition, repeated soaking of the ceramic will cause it to swell and expand. This expansion will cause undue pressure on the ceramic and therefore it may crack and crumble.
 - i) Never throw water into the grill to control flare-ups
 - ii) Do not attempt to operate the infra-red burners in open air while raining.
 - iii) If you find standing water in your grill (because of exposure to rainfall, sprinklers etc.), inspect ceramic for evidence of possible water-soaking. If ceramic appears to be wet, remove the burner from the grill. Turn upside down to drain the excess water. Bring indoors and allow to dry thoroughly.
3. **Impaired Ventilation of Hot Air From the Grill** - In order for the burners to function properly, hot air must have a way to escape the grill. If the hot air is not allowed to escape, the burners may become deprived of oxygen, causing them to back flash. If this occurs repeatedly, the ceramic may crack. Do not cover more than 75% of the cooking surface with solid metal (ie. griddle or large pan).
4. **Burn Off** - Do not clean the ceramic tile with a wire brush. If debris is collecting on your burner, simply light the burner and operate on high for 5 minutes with the lid open, allowing debris to burn off.

TROUBLESHOOTING

Problem	Possible Causes	Solution
Low heat / Low flame when valve turned to high.	Blockage of gas. Improper preheating. Cylinder freezing up.	Check for spider webs in the burner or orifice. Pre-heat grill with main burners on high for 5 to 10 minutes. When cooking for long periods of time, or when the cylinder is close to being empty, or low outside air temperatures, 1 lb cylinders do not have enough wetted surface area to allow liquid propane to turn to vapour. Put on a fresh 1 lb cylinder or hook-up to a 20 lb tank.
Excessive flare-ups/uneven heat.	Sear plate installed incorrectly. Improper pre-heating. Excessive grease and ash build up on sear plates and in drip pan.	Ensure sear plate is installed with the holes towards the right end of the grill. Pre-heat grill with main burners on high for 5 to 10 minutes. Clean sear plate and drip pan regularly. Do not line pan with aluminum foil. Refer to cleaning instructions.
Burners burn with yellow flame, accompanied by the smell of gas.	Possible spider web or other debris, or improper air shutter adjustment.	Thoroughly clean burner by removing. See general maintenance instructions. Open air shutter slightly according to combustion air adjustment instructions.
Flames lift away from burner, accompanied by the smell of gas, and possibly difficulties in lighting.	Improper air shutter adjustment.	Close air shutter slightly according to combustion air adjustment instructions.
Burner will not light with the igniter, but will light with a match.	Damaged electrode wire. Loose electrode wire. Electrode is cracked or broken. Dead battery / or installed incorrectly.	Replace electrode wire. Check that electrode wire is firmly pushed onto the terminal on the back of the igniter. Replace electrode. Replace with heavy duty 'AAA' battery. Install with the positive terminal up.
"Paint" appears to be peeling inside lid or hood.	Grease build up on inside surfaces.	This is not a defect. The finish on the lid and hood is stainless, and will not peel. The peeling is caused by hardened grease, which dries into paint-like shards, that will flake off. Regular cleaning will prevent this. See cleaning instructions.
Burner output on "high" setting is too low. (Rumbling noise and fluttering blue flame at burner surface.) Infra-red only.	Lack of gas. Supply hose is pinched. Dirty or clogged orifice. Spider webs in venturi tube, or other foreign matter. Cracked ceramic tile.	Check gas level in propane cylinder. Reposition supply hose as necessary. Clean burner orifice. Clean out venturi tube. Order replacement burner from your Authorized Napoleon dealer.
Infra-red burner flashes back (during operation the burner abruptly makes a loud "whoosh" sound, followed by a continuous blow-torch type sound and grows dim.)	Ceramic tiles overloaded with grease drippings and build-up, ports are clogged. Burner overheated due to inadequate ventilation (too much grill surface covered by griddle or pan.) Cracked ceramic tile. Leaking gasket surrounding the ceramic tile, or a weld failure in the burner housing.	Turn burner off and allow to cool for at least two minutes. Relight burner and burn on high for at least five minutes or until the ceramic tiles are evenly glowing red. Ensure that no more than 75% of the grill surface is covered by objects or accessories. Turn burner off and allow to cool for at least two minutes, then relight. Allow burner to cool and inspect very closely for cracks. If any cracks are found, contact your authorized Napoleon dealer for ordering a replacement burner assembly. Contact your authorized Napoleon dealer for instructions on ordering a replacement burner assembly.

ORDERING REPLACEMENT PARTS

Contact the factory directly for replacement parts and warranty claims. The customer service department is available between 9 AM and 5 PM (Eastern standard time) at 1-866-820-8686 or fax at 1-705-727-4282. In order to process a claim, we must be provided with the following information:

1. Model and serial number of the unit.
2. Part number and description.
3. A concise description of the problem ('broken' is not sufficient).
4. Proof of purchase (photocopy of the invoice).

In some cases the customer service representative may request to have the parts returned to the factory for inspection, before providing replacement parts. The parts must be shipped prepaid to the attention of the customer service department with the following information:

1. Model and serial number of the unit.
2. A concise description of the problem ('broken' is not sufficient).
3. Proof of purchase (photocopy of the invoice).
4. Return Authorization number - provided by the customer service representative.

Before contacting customer service, kindly note that the following items are not covered by the warranty:

- costs for transportation, brokerage or export duties
- labor costs for removal and re-installation
- costs for service calls to diagnose problems
- discoloration of stainless steel parts
- part failure due to lack of cleaning and maintenance, or use of improper cleaners (ovencleaner).

Item # d'article	Part # / No de pièce	Part Description / Description de la pièce	P215	P1215
1	n010-0409	lid assembly / couvercle	x	x
2	w385-0045	NAPOLEON logo / logo NAPOLÉON	x	x
	w450-0005	logo spring clips / clips à ressort pour logo	x	x
3	n325-0043	lid handle / poignée de couvercle	x	x
4	n380-0008	hook / crochet	x	x
5	n735-0009	lockwasher / rondelle de blocage	x	x
6	n570-0073	screw 1/4-20 x 3/8" / vis 1/4-20 x 3/8"	x	x
7	n570-0056	screw, lid pivot / vis pivot du couvercle	x	x
8	n520-0015	warming rack / grille de réchaud	x	x
9	n335-0035	hood / hotte	x	x
10	n305-0062	cooking grid / grille de cuisson	x	x
11	n570-0020	screw #8-32 x 3/8" / vis #8-32 x 3/8"	x	
12	n735-0010	lockwasher / rondelle de blocage	x	x
13	n240-0015	electrode, infra-red burner / électrode, brûleur infrarouge		x
14	n565-0002	screen, infra-red burner / plaque de protection de brûleur infrarouge		x
15	n010-0411	burner, infra-red / brûleur infrarouge		x
16	n450-0025	locknut / écrou de blocage		x
17	n305-0043	searplate / plaque de brûleur	x	
18	n100-0028	burner, tube / brûleur en tube	x	
19	n240-0011	electrode, tube burner / électrode, brûleur en tube	x	
20	n450-0015	1/4" spring clip / clips à ressort 1/4"	x	
21	n010-0408	base / cuve	x	x
22	n380-0007	latch / loquet	x	x
23	n750-0015	leg / patte	x	x
24	n080-0163	leg retainer bracket - left / boîtier du patte - gauche	x	x
25	n080-0175	leg retainer bracket - right / boîtier du patte - droite	x	x
26	n570-0038	screw 1/4-20 x 1/2" / vis 1/4-20 x 1/2"	x	x
27	n010-0412	dripping / tiroir d'égouttement	x	x
28	n080-0148	regulator mounting bracket / boîtier du régulateur	x	x
29	n080-0154	regulator locking bracket / support de fixation du régulateur	x	x
30	n530-0011	regulator / régulateur	x	x
31	n357-0013	electronic igniter / allumeur électronique	x	x
32	n370-0365	kit, hitch/ball mount / fourmiment, accroc/balle mont	ac	ac
33	n370-0364	kit, wall mount / fourmiment, mur mont	ac	ac
34	n370-0366	kit, marine rail mount / fourmiment, marine barre mont	ac	ac
35	n370-0367	kit, dock/deck post mount / fourmiment, bassin/pont poste mont	ac	ac
36	n590-0120	front shelf / tablette avant	ac	ac
	n020-0109	carry bag / transporter sac	ac	ac
	n200-0066	cover / couvercle	ac	ac

x - standard AC - accessory AC - accessoire

NAPOLEON APPLIANCE CORPORATION ACCESSORIES / PARTS ORDER FORM

FAX TO: 1-705-727-4282

PLEASE PRINT CLEARLY

CUSTOMER NAME: _____

DATE: _____

ADDRESS: _____

MODEL #: _____

SERIAL #: _____

TELEPHONE: _____

VISA OR MASTERCARD #: _____

EXPIRY DATE: _____

QUANTITY	PRODUCT NUMBER	DESCRIPTION

TAXES & SHIPPING CHARGES MAY APPLY

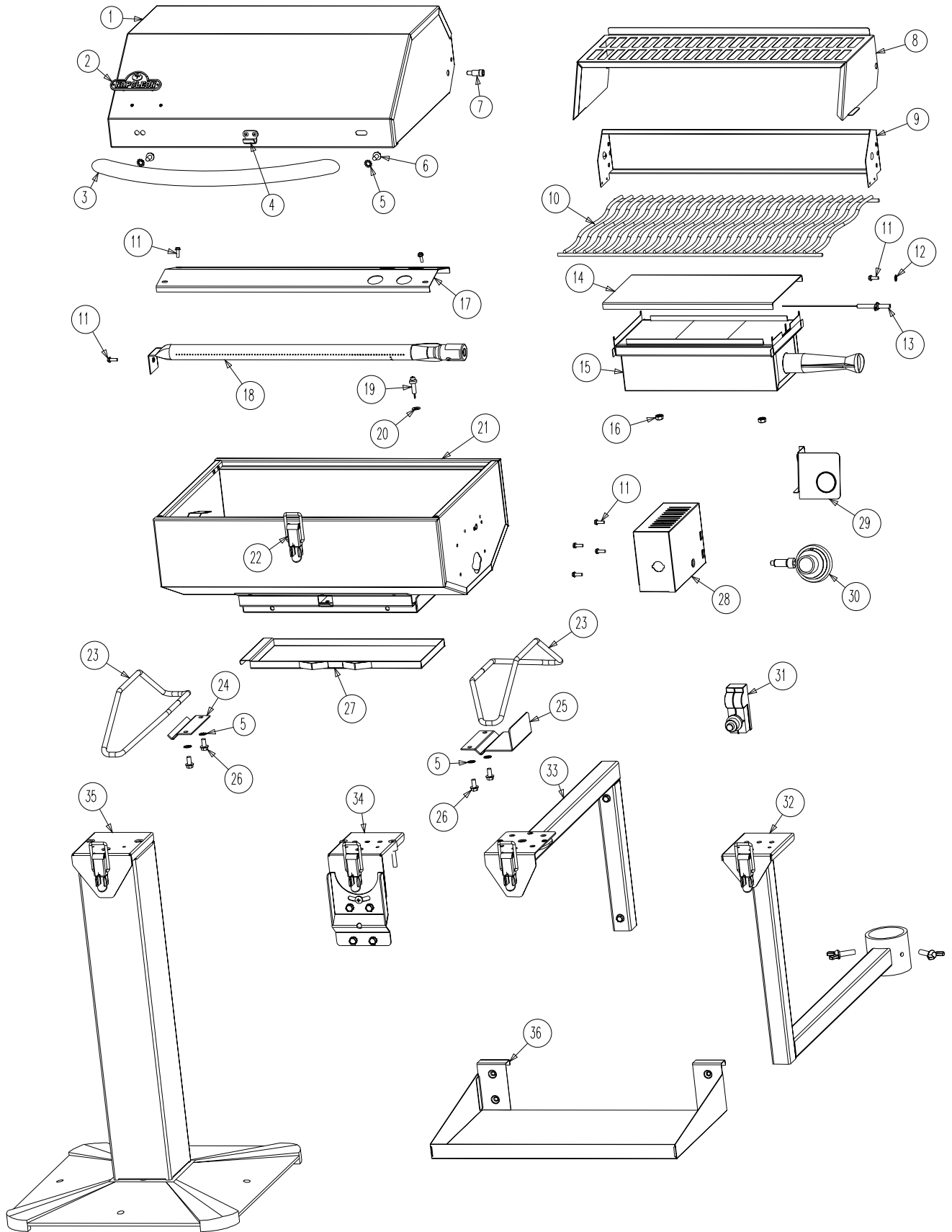

ACCESSORY MOUNTING INSTRUCTIONS

WARNING:

- This grill is not to be used while the vessel is in motion.
- When operating the grill on a vessel, only 8 oz cylinders that are DOT approved (2P/2Q) can be used in the United States. In Canada a 16 oz. cylinder may be used. These cylinders are available at your local marina or hardware store.
- This grill is not to be mounted on a railing while the boat is in motion. It is highly recommended that the grill head is removed and stored away before casting off.

Propane and butane can be more dangerous than gasoline. These gases are heavier than air. If they escape, they collect in the lower parts of the vessel and are very difficult to remove. Make sure all propane appliances and cylinders are properly secured, protected and ventilated, so that escaping gas can not reach bilges or other enclosed spaces. The equipment installation should meet Federal Government standards.

Make sure that all valves are working properly, and that all connections are tight.

When used on a small vessel, this unit must be installed according to the manufacturer's instructions.

This appliance is not to be installed on any small commercial vessel that is carrying passengers.

Do not install or store this appliance in a manner that permits or is likely to permit ingress or trapping of the gas below deck.

This grill is not to be operated within a cabin or any other enclosed area. This grill is to be used outdoors only.

Rail Mount Instructions:

1. Place mount "A" on the outside of the railing, with the mounting platform facing up.
2. Attach mount "B" to mount "A" using the four 1/4-20 x 1" bolts.
3. Level the platform and tighten the top two bolts first. Be sure the platform is pinched tight before tightening the bottom two bolts.
4. The platform can also be adjusted left to right by loosening the top two bolts and centre pivot screw. Once the platform is adjusted, tighten all three fasteners.
5. Once the platform is level in both directions, the grill can be mounted:
 - a. Lock the lid of the grill closed with the latch.
 - b. Hold the grill by the handle with one hand, place the other hand under the grill in the centre of the front tapered surface.
 - c. Place the grill bottom on the platform and slide it forward to engage the tab protruding from the bottom of the grill. Ensure that the tab is properly engaged.
 - d. When the dimples on the bottom of the unit line up with the holes on the platform, the latch is ready to be fastened.
6. Under extreme conditions, the bracket may pivot around the railing. A centre hole has been provided to allow a bolt to be fastened through the rail to prevent the grill from pivoting on the rail.
7. Once the grill has been attached, thread the regulator (clockwise) into the regulator mount. On tube burner version, lift the burner slightly to align it with the orifice. Tighten by hand.
8. To fasten the regulator locking bracket, locate it at the bottom back corner of the regulator mount and turn the regulator until the gas inlet is aligned with the hole in the regulator locking bracket. Slide the locking bracket forward until the two tabs engage into the slots on the regulator mount. Tap in firmly.
9. Attach the cylinder to the regulator by turning clockwise. (Be sure not to cross thread the cylinder.)

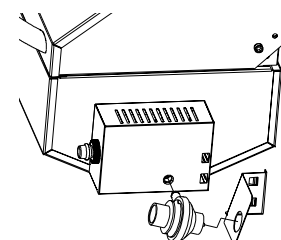
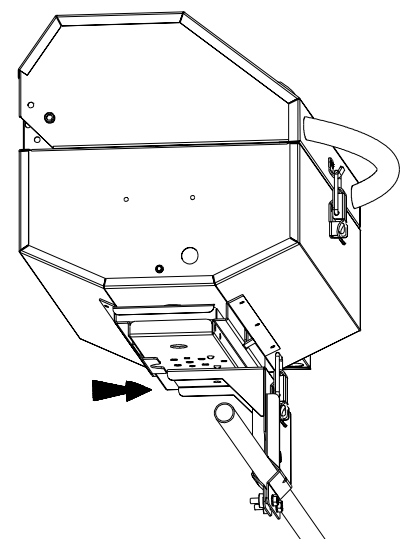
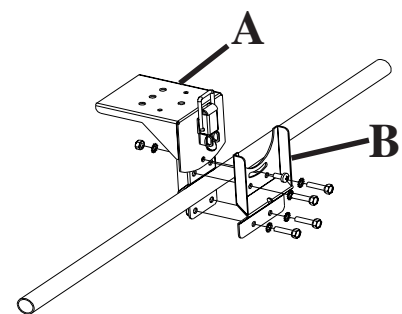

Wall Mounting Instructions:

1. Using the two holes provided in the vertical tube, mount the bracket to the wall.
2. Ensure minimum clearance to combustibles are maintained, 4" (100mm) to sides, and 6" (150mm) from the rear.
3. Do not locate the grill under unprotected combustible construction.
4. The platform may be swivelled by removing the two #8 x 3/8" flathead phillips screws and turning the platform to the desired angle. Replace the two screws and tighten.
5. Once the platform is located in the desired position, the grill can be mounted:
 - a. Lock the lid of the grill closed with the latch.
 - b. Hold the grill by the handle with one hand, place the other hand under the grill in the centre of the front tapered surface.
 - c. Place the grill bottom on the platform and slide it forward to engage the tab protruding from the bottom of the grill. Ensure that the tab is properly engaged.
 - d. When the dimples on the bottom of the unit line up with the holes on the platform, the latch is ready to be fastened.
6. Once the grill has been attached, thread the regulator (clockwise) into the regulator mount. On tube burner version, lift the burner slightly to align it with the orifice. Tighten by hand.
7. To fasten the regulator locking bracket, locate it at the bottom back corner of the regulator mount and turn the regulator until the gas inlet is aligned with the hole in the regulator locking bracket. Slide the locking bracket forward until the two tabs engage into the slots on the regulator mount. Tap in firmly.
8. Attach the cylinder to the regulator by turning clockwise. (Be sure not to cross thread the cylinder.)

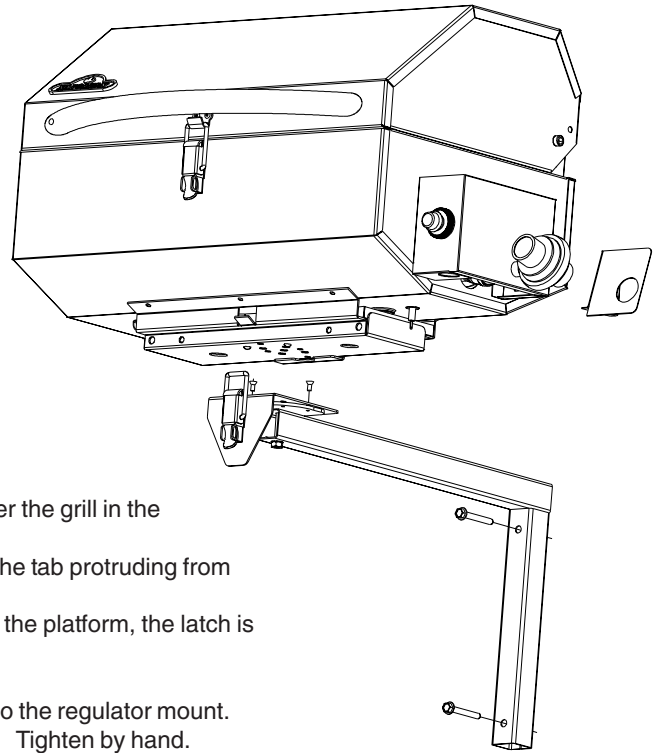

Trailer Ball Mounting Instructions:

1. Place the ball mount over the ball on your drawbar or bumper.
2. Tighten the two wing screws until the mount is firmly held in place.
3. Once the mounting arm is tight, the grill can be mounted:
 - a. Lock the lid of the grill closed with the latch.
 - b. Hold the grill by the handle with one hand, place the other hand under the grill in the centre of the front tapered surface.
 - c. Place the grill bottom on the platform and slide it forward to engage the tab protruding from the bottom of the grill. Ensure that the tab is properly engaged.
 - d. When the dimples on the bottom of the unit line up with the holes on the platform, the latch is ready to be fastened.
4. Once the grill has been attached, thread the regulator (clockwise) into the regulator mount. On tube burner version, lift the burner slightly to align it with the orifice. Tighten by hand.
5. To fasten the regulator locking bracket, locate it at the bottom back corner of the regulator mount and turn the regulator until the gas inlet is aligned with the hole in the regulator locking bracket. Slide the locking bracket forward until the two tabs engage into the slots on the regulator mount. Tap in firmly.
6. Attach the cylinder to the regulator by turning clockwise. (Be sure not to cross thread the cylinder.)

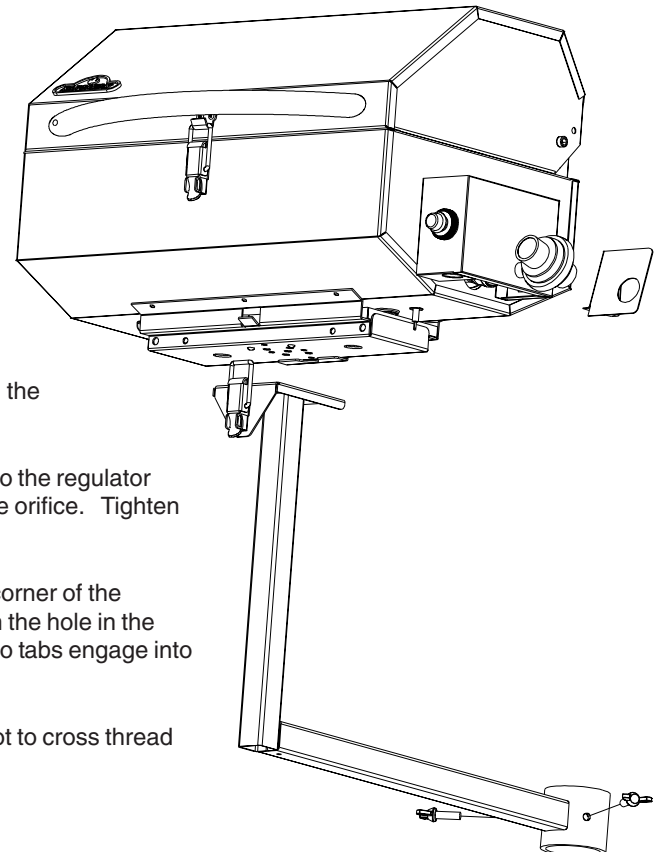

Post Mounting Instructions:

1. Remove all the parts from the packaging.
2. Attach the post to the casting using four 1/4-20 x 1" hex head bolts. Ensure that the holes on the back side of the post face the same direction as the groove on the bottom back of the foot casting.
3. Place the spacers provided on the three nutserts that are closest to the front of the post.
4. Place the platform with the latch to the front onto the three spacers. Attach with the three 1/4-20 x 1 3/4" flat head bolts. Tighten firmly in place.
5. Attach the back post cover with the two #8 screws provided.
6. Once the post is completely assembled, the grill can be mounted:
 - a. Lock the lid of the grill closed with the latch.
 - b. Hold the grill by the handle with one hand, place the other hand under the grill in the centre of the front tapered surface.
 - c. Place the grill bottom on the platform and slide it forward to engage the tab protruding from the bottom of the grill. Ensure that the tab is properly engaged.
 - d. When the dimples on the bottom of the unit line up with the holes on the platform, the latch is ready to be fastened.
7. Once the grill has been attached, thread the regulator (clockwise) into the regulator mount. On tube burner version, lift the burner slightly to align it with the orifice. Tighten by hand.
8. To fasten the regulator locking bracket, locate it at the bottom back corner of the regulator mount and turn the regulator until the gas inlet is aligned with the hole in the regulator locking bracket. Slide the locking bracket forward until the two tabs engage into the slots on the regulator mount. Tap in firmly.
9. Attach the cylinder to the regulator by turning clockwise. (Be sure not to cross thread the cylinder.)

