

This Owner's Manual is provided and hosted by [Appliance Factory Parts](http://www.appliancefactoryparts.com).



# MASTERCRAFT MBS-2000EF Owner's Manual

[Shop genuine replacement parts for MASTERCRAFT  
MBS-2000EF](#)



[Find Your MASTERCRAFT Burnisher Parts - Select From 6 Models](#)

----- Manual continues below -----



# 1000 / 1500 / 2000 RPM BURNISHERS SAFETY, OPERATION & MAINTENANCE MANUAL

READ & FOLLOW ALL INSTRUCTIONS,  
WARNINGS & CAUTIONS  
BEFORE USING THIS BURNISHER

This burnisher will afford you many years of trouble free operating satisfaction if it is given proper care. All parts have passed rigid quality control standards before being assembled to produce the finished product. Prior to packaging, the units again inspected for assurance of flawless assembly.

Your burnisher was protectively packed to prevent damage in shipment. We recommend that upon delivery, remove the unit from its carton and carefully inspect it for any possible damage in transit.

If damage is discovered, immediately notify the transportation company that delivered your burnisher. As a shipper, we are unable to act upon any claim for concealed damage. You must originate any claim within 5 days of delivery.

These instructions are for your protection and information. **PLEASE READ CAREFULLY!** Failure to follow these precautions could result in injury or discomfort.

READ ALL  
INSTRUCTIONS  
BEFORE  
OPERATING

SAVE THESE INSTRUCTIONS

# IMPORTANT SAFETY INSTRUCTIONS



## WARNING:

To reduce the risk of fire, electric shock or injury:  
When using an electric burnisher, basic precautions should always be following, including the following:

- 1) **DO NOT** leave burnisher plugged in when not in use. Unplug from outlet when not in use and before servicing.
- 2) Electric shock could occur if exposed to rain. Store indoors.
- 3) This is **NOT** a toy. Close attention is necessary when used around or near children.
- 4) Use only as described in this manual. Use only manufacturer's recommended attachments.
- 5) **DO NOT** use with damaged cord plug. When burnisher is not working as it should because it has been dropped, damaged, left outdoors, or dropped into water, contact the manufacturer or authorized service center.
- 6) **DO NOT** pull or carry by the cord, use power cord as a handle, close a door on cord, or pull cord around sharp edges or corners. **DO NOT** run burnisher over cord. Keep cord away from heated surfaces.
- 7) **DO NOT** handle the burnisher plug with wet hands.
- 8) **DO NOT** unplug by pulling on the cord. To unplug, grasp the plug, not the power cord.
- 9) **DO NOT** put any objects into motor openings.
- 10) Keep hair, loose clothing, fingers and all parts of body away from moving parts.
- 11) **DO NOT** operate where oxygen or anesthetics are used.
- 12) **DO NOT** use around flammable or combustible liquids such as gasoline or use in areas where they may be present.
- 13) **DO NOT** use an extension cord unless absolutely necessary. If an extension cord is used, then wire size must be #14 gauge or thicker and should not exceed 50 feet in length. Extension cord must be three-wire type to insure grounding protection.
- 14) Replace damaged or worn parts immediately with genuine original equipment parts to maintain safety and to protect your limited warranty.

# GROUNDING SAFETY INSTRUCTIONS



## DANGER:

Improper use of the grounding plug can result in a risk of electric shock.

This burnisher must be grounded. If it should malfunction or breakdown, grounding provides a path of least resistance for electrical current to reduce the risk of electric shock. The burnisher is equipped with a cord having an equipment-grounded plug. The plug must be inserted into an appropriate outlet that is properly installed and grounded in accordance with all local codes and ordinances

If repair or replacement of the cord or plug is necessary, **DO NOT** connect the grounding wire to either flat blade terminal. The wire with insulation having an outer surface that is green with or without yellow stripes is the grounding wire.

## GROUNDING METHODS

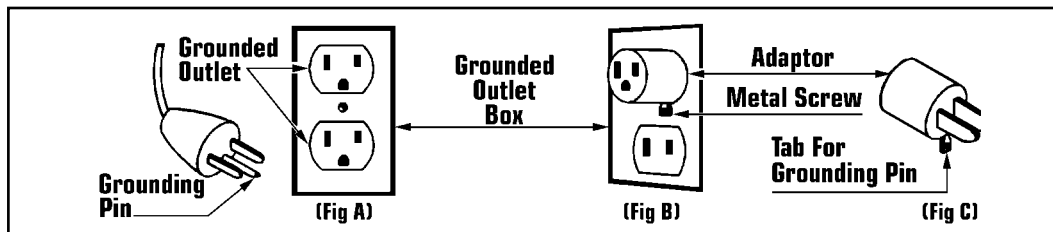

This burnisher is for use on a nominal 120 volt circuit, and has a grounding plug that looks like the plug illustrated in (Fig A). A temporary adaptor that looks like the adaptor illustrated in (Fig B & C) may be used to connect the plug to a 2-pole receptacle as shown in (Fig A) if a properly grounded outlet is not available.

The temporary adaptor should be used only until a properly grounded outlet (Fig A) can be installed by a qualified electrician. The green color rigid ear, lug, or the like extending from the adaptor must be connected to a permanent ground such as a properly grounded outlet box cover. Whenever the adaptor is used, it must be held in place by the metal screw (Fig C).

**NOTE:**  
In Canada, the use of a temporary adaptor is not permitted by the Canadian Electrical Code.



### WARNING:

Improper connection of the equipment-grounding conductor can result in a risk of electrical shock. Check with a qualified electrician or service person if you are in doubt as to whether the outlet is properly grounded.

**DO NOT** modify the plug provided with the burnisher. If it will not fit the outlet, have a proper outlet installed by a qualified electrician.



### WARNING:

To avoid fire, **DO NOT** use with a flammable or combustible liquid to clean a floor.

## OPERATING INSTRUCTIONS

This burnisher can be used in conjunction with any of the ultra high speed chemical systems. It is mandatory, however, that the floor be prepared as directed by the chemical manufacturer. This will eliminate a possibility of damage to floor due to the burnisher's high speed.

The burnisher is pre-set at the factory for use with a 1" thick buffing pad (1 shpd w/unit). The rougher hair surface is preferred for high luster floor finishing.

1. Before operating this burnisher, check to see that the buffing pad is properly centered on driver and that center pad lock is tight on pad.

2. When operating the burnisher it **MUST** be kept moving, as holding machine stationary while running will result in damage to floor and floor finish.

3. Begin operating the burnisher at the closest point to your electrical outlet and work away from the outlet. This will prevent running over the electric cord.

4. Never leave burnisher resting on buffing pad for an extended period of time. This will cause buffing pad to lose its normal shape, causing wobbling or vibration and pad must be replaced. Also, replace pad if glazed, clogged, torn or shredded.

5. The rear wheels on the 1500 RPM and 2000 RPM burnishers are factory-set for low amp rating and high luster burnishing with buffing pad. See instruction sheet.

6. A carbon brush wear indicator warning light is located on the motor canopy. When lit, motor carbon brushes must be replaced within 20 hours running time to prevent damage to motor. See instruction sheet.



### CAUTION:

This burnisher is **NOT** a low speed floor machine. **DO NOT** use the burnisher for stripping or sanding of floors.

## CARE AND MAINTENANCE

This burnisher requires limited maintenance for proper operation and years of service.

- 1) After each use, wipe off all of the polished and painted areas with a clean cloth.
- 2) Check all bolts and screws at the switch box, handle and wheels. Tighten if they are loose and replace any that are broken.

3) Unplug burnisher and check power cord for and breaks in the wire. Breaks will most likely occur near the plug or switch. Any breaks should be repaired or replaced immediately.

4) When the burnisher is not in use, remove buffing pad, unplug power cord and wrap it around the cord hooks. Store in a dry area.

## TROUBLE SHOOTING GUIDE

### PROBLEM: Not polishing floor to high luster.

---

#### POSSIBLE CAUSE:

- 1) Improperly prepared floor or floor needs refinishing.
- 2) Buffing pad is flattened from unit sitting on pad.
- 3) Hard glazed surface on pad.
- 4) Pad used on wet surface or clogged with dirt.
- 5) Pad too thin.
- 6) Burnisher out of adjustment, rear wheels shifted.

#### POSSIBLE SOLUTION:

- 1) Refinish floor.
- 2) Replace with new 1" buffing pad.
- 3) Replace with new 1" buffing pad.
- 4) Replace with new 1" buffing pad.
- 5) Replace with new 1" buffing pad.
- 6) Have a certified technician adjust rear wheels.

### PROBLEM: pulling to one side or skipping sideways.

---

#### POSSIBLE CAUSE:

- 1) Buffing pad too thick for machine setting.
- 2) Rear wheels are out of adjustment.

#### POSSIBLE SOLUTION:

- 1) Replace with 1" buffing pad.
- 2) Have a certified technician adjust rear wheels.

### PROBLEM: Machine not running.

---

#### POSSIBLE CAUSE:

- 1) Defective power cord.
- 2) Defective switch.
- 3) Defective motor.
- 4) Motor unplugged from handle cord.

#### POSSIBLE SOLUTION:

- 1) Contact Manufacturer or Service Center.
- 2) Contact Manufacturer or Service Center.
- 3) Contact Manufacturer or Service Center.
- 4) Plug motor lead into handle cord receptacles.



777 South Street, P.O. Box 2310, Newburgh, NY 12550-0606

TEL: (800) 835-7812 • (845) 565-8850

FAX: (800) 752-6883 • (845) 565-9392

Internet Access:

www.mastercraftusa.com • sales@mastercraftusa.com

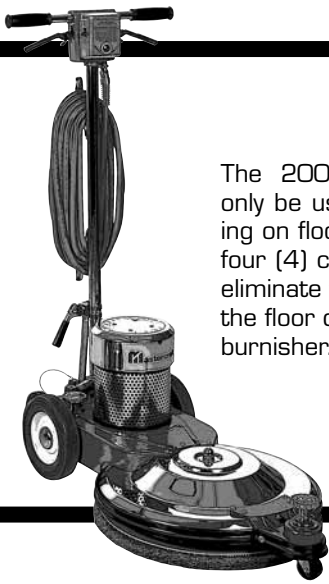

The 2000 RPM burnisher should only be used for high luster burnishing on floors that have a minimum of four (4) coats of floor finish. This will eliminate the possibility of damage to the floor due to the high speed of the burnisher.

# 2000 RPM BURNISHER OPERATING INSTRUCTIONS

This unit is intended for commercial use.

## OPERATION INSTRUCTIONS

Begin operating this burnisher at the closest point to your electrical outlet, working away from the outlet. This will prevent running over the electric cord. Operate the burnisher in a straight-line path and avoid continuous operation in one spot.

**If burnisher wobbles, vibrates or pulls, follow these instructions:**

**1)** Never leave burnisher resting on floor pad overnight. This will cause the pad to lose its normal shape, causing wobbling and vibration. Check pad for unevenness and change is necessary.

**2)** Before turning burnisher on, run tip of finger between outside of pad and floor. The outer ring face should be in full contact with the floor in order for high speed buffing to be most effective. If necessary change pad.

**3)** If necessary adjust front and rear wheels:

Pad pressure becomes more critical with a 2000 RPM burnisher. If excessive current draw is permitted, either a blown circuit breaker or motor damage will occur.

**Front Caster Adjustment:**

**1)** To increase pad pressure as well as amperage draw "Lower" front caster adjustment.

**2)** To reduce the pad pressure as well as amperage draw "Raise" front caster adjustment.

Proper pad adjustment is best achieved by lowering front caster until the warning light located in the switch box activates. Then raise the front caster slowly until the warning light shuts OFF.

The rear wheels are adjusted and locked in place at the factory to assure proper alignment. The pre-set adjustment is based on the floor pad supplied with this burnisher. To adjust for normal pad wear follow instructions for Front Caster Adjustment.

The rear wheel position should ONLY be reset by a certified technician. To reset rear wheels:

**1)** Attach floor pad.

**2)** Unlock rear wheel set screw using a 3/32" allen wrench and "Raise" all three adjustment knobs until the buffing pad is positioned 5/8" off the floor, around the pad perimeter.

**3)** Lock rear wheel set screws.

**4)** It may be necessary to adjust pad pressure. Follow the Front Caster Adjustment Instructions.

**First Warning System** is located on the control box face. When the red warning light comes ON do the following.

**1)** Raise front knob slowly until light is **OUT**. If the light fails to go **OUT**, see step 2.

**2)** Turn pad over or install a clean pad.

**Second Warning System** is a carbon brush wear indicator light located on the motor canopy. Instructions read as follows:

*When lamp is lit, Motor Carbon Brush **MUST** be replaced within 20 hours of service to prevent damage to the motor.*

**Carbon Brushes Part Nos:**

**Imperial Motor:** Part No 386790 (4)  
**Ohio Motor\*:** Part No 380083 (3) & 316954 (1)

\* Burnishers with Ohio Motors have "X" after the serial number.

**Note:** After replacing the second set of carbon brushes, the commutator of the armature may need to be undercut and the mica slotted. This should be done by an experienced motor repair shop.

## WARNING LIGHT SYSTEM

# HANDLE ASSEMBLY INSTRUCTIONS

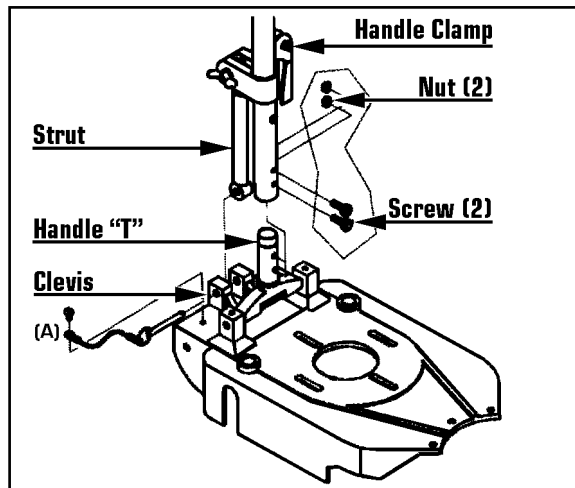

This burnishers is shipped without the handle attached to the chassis. Handle hardware kit (#372811) contains the necessary parts to attach the handle to the burnisher.

**1)** Remove burnisher chassis and handle assembly for the carton.

**2)** Using screws #353272 and nuts #354791, insert one screw into each hole and secure with nuts on opposite side of handle tube. **DO NOT** over-tighten nuts, this will deform the handle tube.

**3)** Slide the handle assembly over handle "T" on the chassis making sure the line cord is towards back of burnisher and loosen handle clamp.

**4)** Remove speed-pin (A) from clevis. Line up strut with clevis and insert speed-pin (A) thru clevis and strut.

# FLOOR PAD INSTALLATION

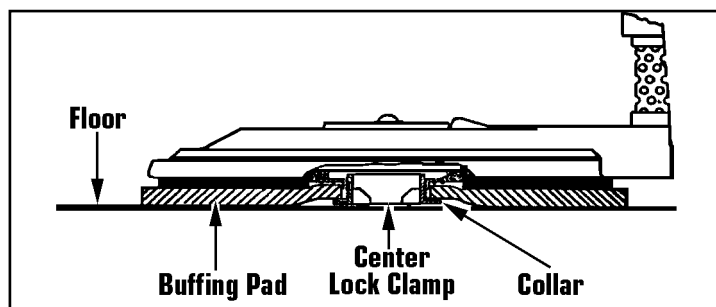

The floor pad packed with this burnisher **MUST BE** attached to pad driver before operating the unit.

**DO NOT OPERATE** the burnisher pad driver without the pad securely in place to avoid damage to the floor and/or burnisher.

To Install Pad:

**1)** Remove center cut-out from the floor pad

**2)** Tilt burnisher back on rear wheel and unscrew center lock clamp pad retainer by turning counterclockwise in "OPEN" position.

**3)** Center pad on center lock clamp or collar with hair side down for optimum finish.

**4)** Secure the pad to pad driver by turning the center lock clamp clockwise in the "CLOSE" position until it is locked in position.

# CARE AND MAINTENANCE

**1.** After each use, wipe off all polished and painted areas with a clean cloth.

**2.** Check all bolts and screws at the switch box, handle and wheels. Tighten if they are loose and replace any that are broken.

**3.** Unplug burnisher and check power cord for any breaks in the wire. Breaks will most likely occur near the plug or switch. Any breaks should be repaired or replaced immediately.

**4.** When the burnisher is not in use, remove buffing pad, unplug power cord and wrap it around the cord hook. Store in a dry area.