

This Owner's Manual is provided and hosted by [Appliance Factory Parts](#).



# Kenmore 58826 Owner's Manual

[Shop genuine replacement parts for Kenmore 58826](#)



[Find Your Kenmore Refrigerator Parts - Select From 665 Models](#)

----- Manual continues below -----



**SXS REFRIGERATOR**

# REFRIGERATOR SERVICE MANUAL

**CAUTION**  
BEFORE SERVICING THE UNIT,  
READ THE SAFETY PRECAUTIONS IN THIS MANUAL.

**MODELS:**

795.58822.900  
795.58823.900  
795.58826.900  
795.58829.900

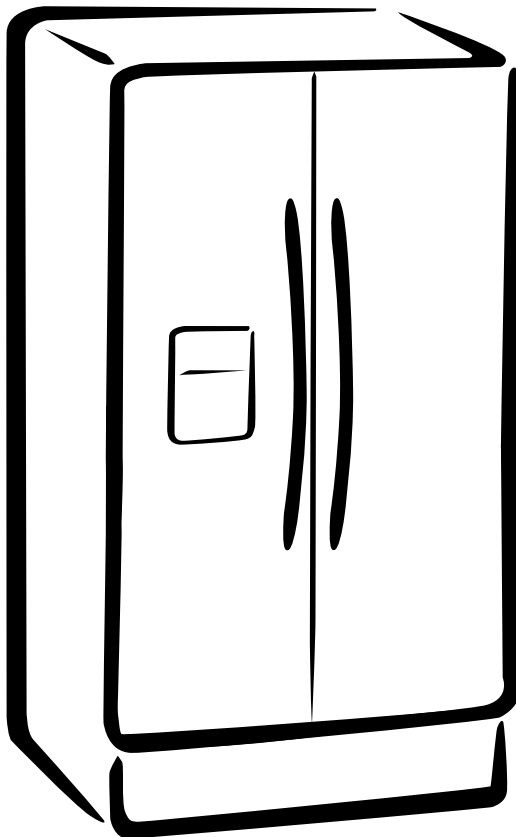

# CONTENTS

---

<b>WARNINGS AND SAFETY PRECAUTIONS .....</b>	<b>3</b>
<b>1. SPECIFICATIONS .....</b>	<b>4</b>
<b>2. PARTS IDENTIFICATION .....</b>	<b>5</b>
<b>3. HOW TO INSTALL REFRIGERATOR .....</b>	<b>6</b>
<b>4. MICOM FUNCTION .....</b>	<b>9</b>
<b>5. CIRCUIT .....</b>	<b>15</b>
<b>6. EXPLANATION FOR MICOM CIRCUIT .....</b>	<b>17</b>
<b>7. ICEMAKER AND DISPENSER WORKING PRINCIPLES AND REPAIR.....</b>	<b>28</b>
<b>8. TROUBLE DIAGNOSIS .....</b>	<b>31</b>
<b>9. HOW TO DISASSEMBLE AND ASSEMBLE.....</b>	<b>69</b>
<b>10. EXPLODED VIEW AND .....</b>	<b>74</b>
<b>795.58822/58823/58826/58829.900 .....</b>	<b>80</b>

# WARNINGS AND PRECAUTIONS FOR SAFETY

---

Please observe the following safety precautions to use the refrigerator safely and correctly and to prevent accident or injury when servicing.

1. Be careful of an electric shock. Disconnect power cord from wall outlet and wait for more than three minutes before replacing PWB parts. Shut off the power whenever replacing and repairing electric components.
2. When connecting power cord, please wait for more than five minutes after power cord was disconnected from the wall outlet.
3. Please check if the power plug is pressed by the refrigerator against the wall. If the power plug was damaged, it could cause fire or electric shock.
4. If the wall outlet is overloaded, it may cause a fire. Please use a dedicated circuit for the refrigerator.
5. Please make sure the outlet is properly grounded. Particularly in a wet or damp area.
6. Use standard electrical components.
7. Make sure hooks are correctly engaged. Remove dust and foreign materials from the housing and connecting parts.
8. Do not fray, damage, run over, kink, bend, pull out, or twist the power cord.
9. Please check for evidence of moisture intrusion in the electrical components. Replace the parts or mask with insulation tape if moisture intrusion was confirmed.
10. Do not touch the icemaker with hands or tools to confirm the operation of geared motor.
11. Do not suggest that customers repair their refrigerator themselves. This work requires special tools and knowledge. Non-professionals could cause fire, injury, or damage to the product.
12. Do not store flammable materials such as ether, benzene, alcohol, chemicals, gas, or medicine in the refrigerator.
13. Do not put anything on top of the refrigerator, especially something containing water, like a vase.
14. Do not put glass bottles with full of water into the freezer. The contents will freeze and break the glass bottles.
15. When you scrap or discard the refrigerator, remove the doors and dispose of it where children are not likely to play in or around it.

# 1. SPECIFICATIONS

## 1-1 DISCONNECT POWER CORD BEFORE SERVICING IMPORTANT - RECONNECT ALL GROUNDING DEVICES

All parts of this appliance capable of conducting electrical current are grounded. If grounding wires, screws, straps, clips, nuts or washers used to complete a path to ground are removed for service, they must be returned to their original position and properly fastened.

## 1-2 IMPORTANT NOTICE

This information is intended for use by individuals possessing adequate backgrounds of electrical, electronic and mechanical experience. Any attempt to repair a major appliance may result in personal injury and property damage. The manufacturer or seller cannot be responsible for the interpretation of this information, nor can it assume any liability in connection with its use.

## 1-3 ELECTRICAL SPECIFICATIONS

Temperature Control (Position: MID).....	-6°F to +8°F
Defrost Control.....	Automatic
Defrost Thermostat.....	50°F
Electrical Rating: 115VAC, 60Hz.....	1-7 A
Maximum Current Leakage.....	0.5mA
Maximum Ground Path Resistance.....	0.1 Ohms
Energy Consumption.....	27 cu.ft. 590kWh/yr (Energy Star)

## 1-4 NO LOAD PERFORMANCE

### Control Position: MID/MID

And ambient of:.....70°F .....90°F

Fresh Food, °F.....33°F to 41°F .....33°F to 41°F

Frozen Food, °F.....-4°F to +4°F .....45%-60%

Percent Running Time.....

## 1-5 REFRIGERATION SYSTEM

Minimum Compressor Capacity Vacuum.....21 in

Minimum Equalized Pressure

@ 70°F .....49PSIG

@ 90°F .....56PSIG

Refrigerant R134a.....6.5 oz

Compressor.....950BTU/hr

## 1-6 INSTALLATION

For proper air circulation, best cooling and energy consumption results, maintain a minimum distance of 2 inches (5.08cm) from adjacent items and surfaces.

### CLEARANCE

AT TOP.....2 in

AT SIDES.....2 in

AT REAR.....2 in

## 1-7 REFRIGERATION SYSTEM

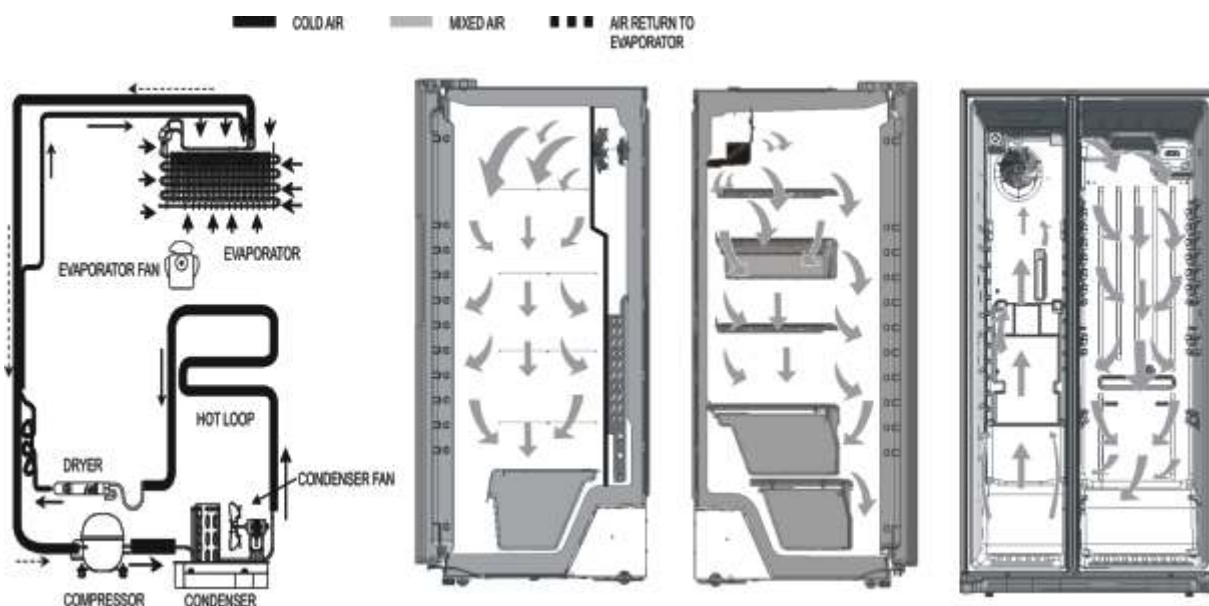

# 2. PARTS IDENTIFICATION

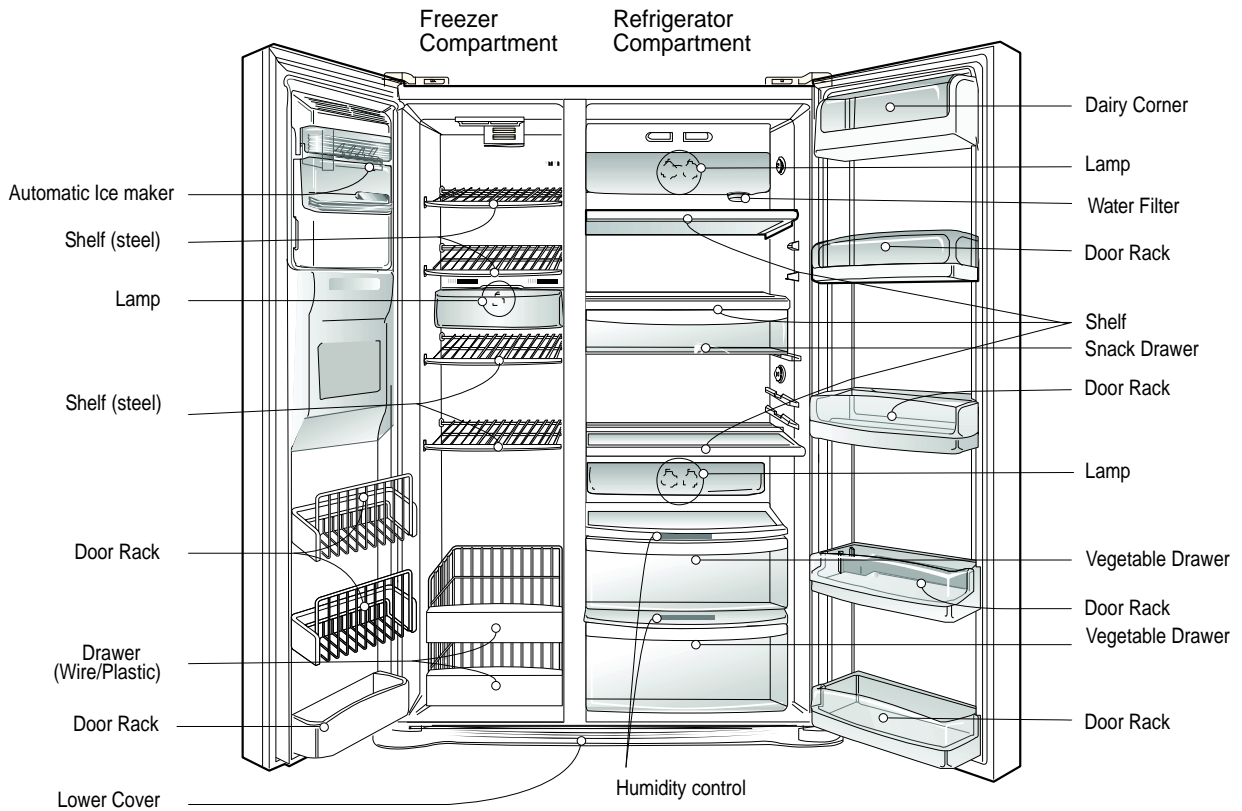
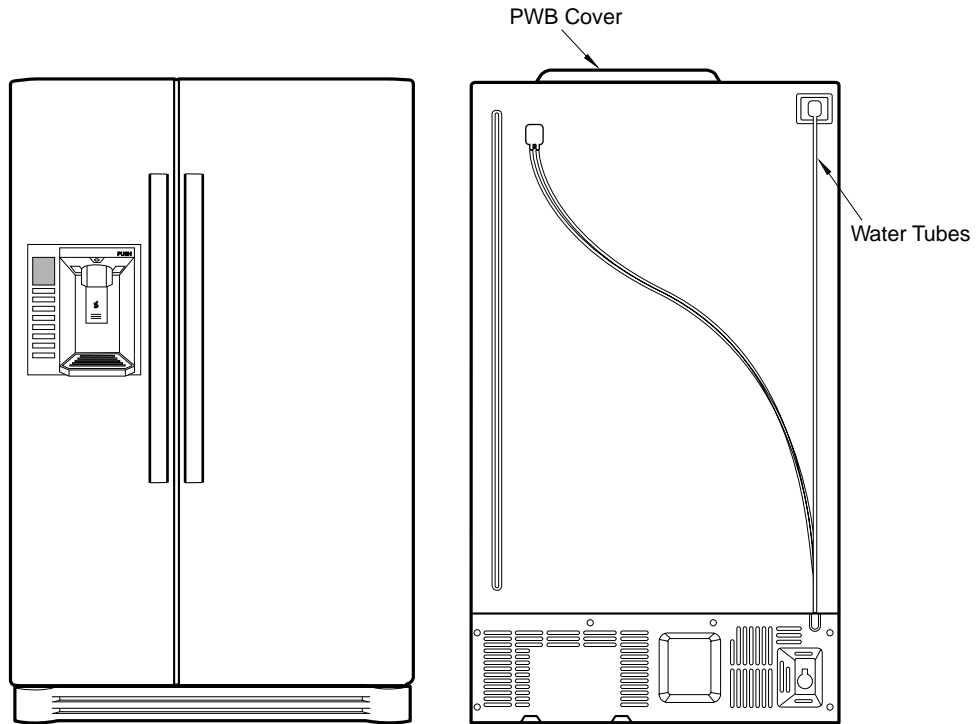

• If you find some parts missing from your unit they may be parts only used in other models.

# 3. HOW TO INSTALL REFRIGERATOR

## 1. How to Adjust Door Height of Refrigerator

Make the refrigerator level first. (If the refrigerator is not installed on a flat floor, the height of freezer and refrigerator door may not be the same.)

### 1. If the freezer door is lower than the refrigerator door:

### 2. If the freezer door is higher than the refrigerator door:

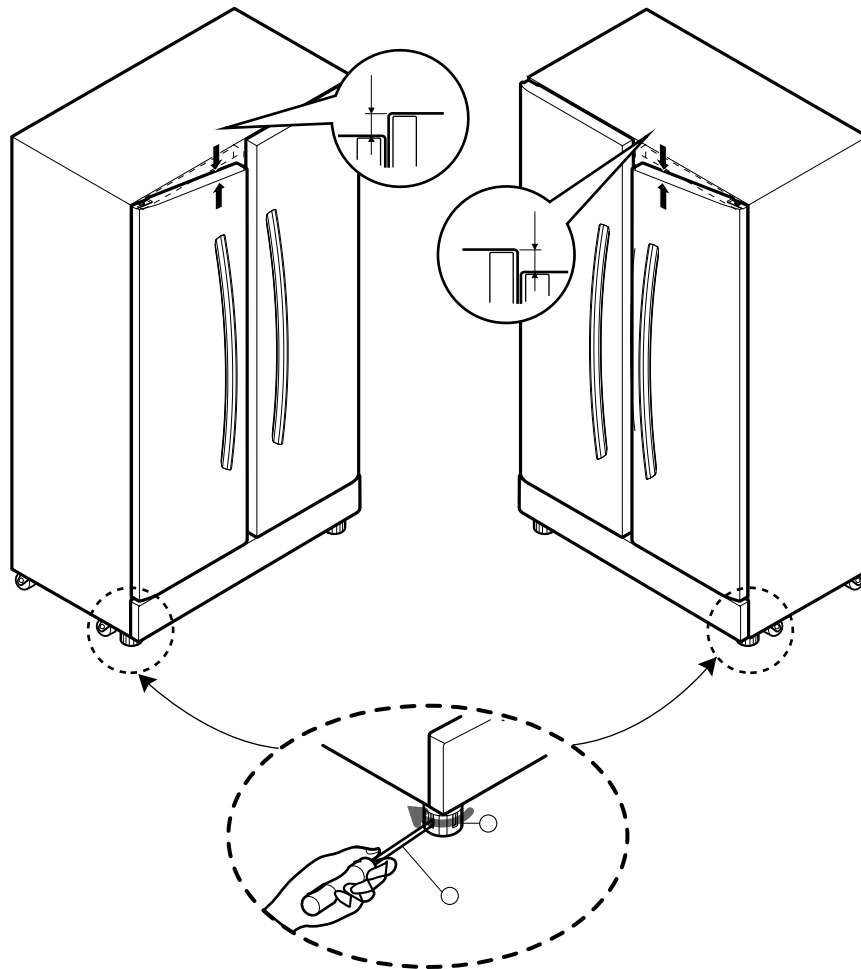

Adjust the level when the refrigerator door is lower than the freezer door during the use of the refrigerator.

1. Using the narrow side of the tool for adjustment, turn the adjustment hinge pin 1 (↻) clockwise or (↺) counterclockwise to level the refrigerator and freezer door.
2. After setting the level of the door, turn the keeper nut (↺) counterclockwise to tighten.

The refrigerator door will close smoothly by raising the front side by adjusting the height adjusting screw. If the door does not close properly because it is improperly adjusted, the performance of the refrigerator will be affected.

Do not force too hard to level the height. The hinge pin can be pulled out. (Adjustable range of height is a maximum of 0.2" (0.508 cm))

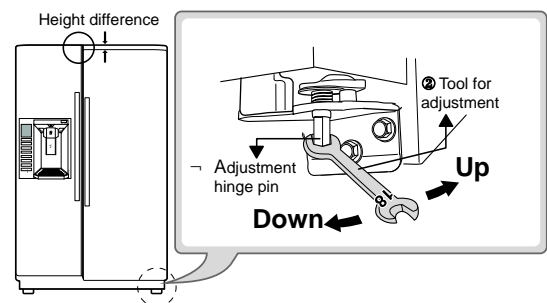

## 2. Install Water Filter (Applicable to some models only)

### Before Installing Water Filter

1. Before installing the filter, take out the top shelf of the refrigerator after tilting it to the direction and lifting it to the direction and move it to the lower part.
2. Remove the lamp cover by pressing the protrusion under the cover and pulling the cover to the front.

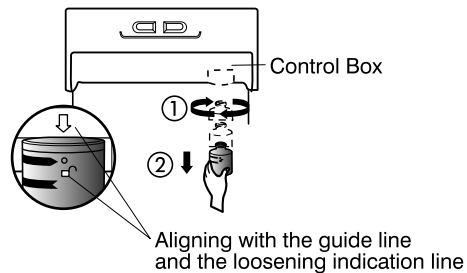
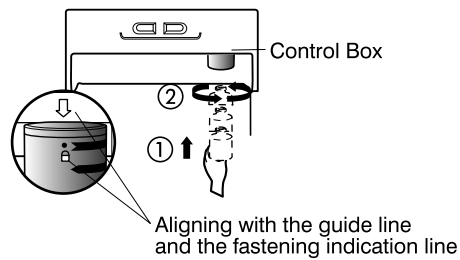
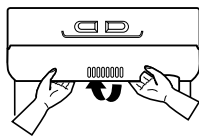
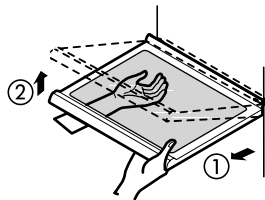

### Installing water filter

#### 1. Initial installation of water filter

Remove the filter substitute cap by turning it counterclockwise by 90 degrees and pulling it down.

**Note:** Keep the cap safe to use it later when you do not use the filter.

Remove the red cap from the filter and attach the sticker. Insert the upper part of the filter after aligning with the guideline marked on the control box, and fasten it by turning it clockwise by 90 degrees.

**Note:** Check that the guideline and the fastening indication line are aligned.

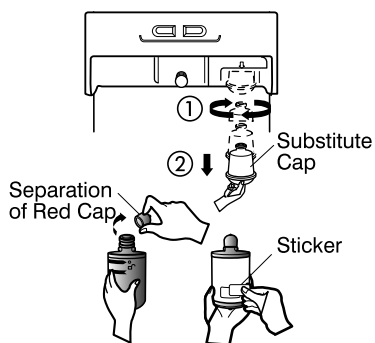

#### 2. Replacement of water filter

While holding the lower part of the filter, turn it counterclockwise by 90 degrees and pull it down.

**Note:** Check that the guideline and the loosening indication line are aligned.

### After installing water filter

Reassemble the lamp cover and the top shelf of the refrigerator. To place the top shelf of the refrigerator, raise the front part of the shelf a bit so that the hook of the shelf fits into the groove.

To purge the water filter system, let the water run for at least 3 minutes.

**NOTE:** Open the refrigerator and check for water droplets on the shelf under the filter.

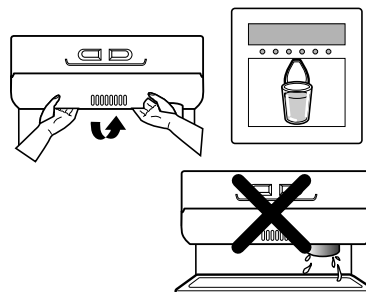



### 3. How to Control the Amount of Water Supplied to Icemaker.

#### 3-1. Confirm the amount of water supplied to the icemaker.

##### 1) Confirm the amount of water supplied to the icemaker

- (1) Press the button (Figure 1) to select the level of water (Optimum level Large Small.)

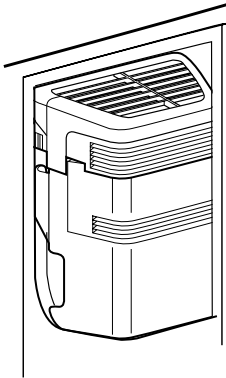

##### 2) Icemaker Operation Test (Test mode)

- (1) Press the button (Figure 1) for more than 3 seconds and It will start the Test mode.
- (2) Test the operation of the operating part of the icemaker.
- (3) If there is no problem with the operation, water is supplied through the water tube (up to the selected level of water).
- (4) The test mode is completed after the water is supplied.

Note : When using the test mode more than twice consecutively, water can overflow.  
When the water overflows, wipe the ice storage bin.

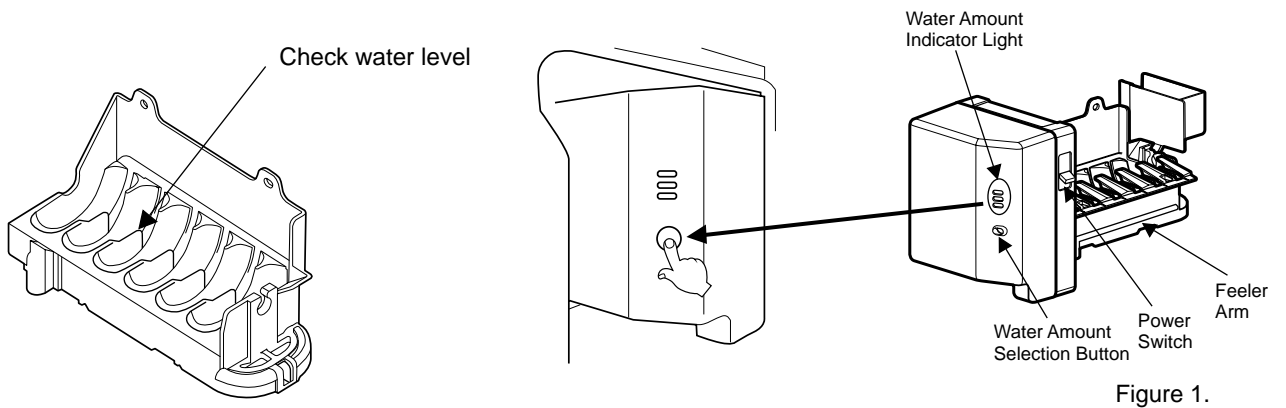
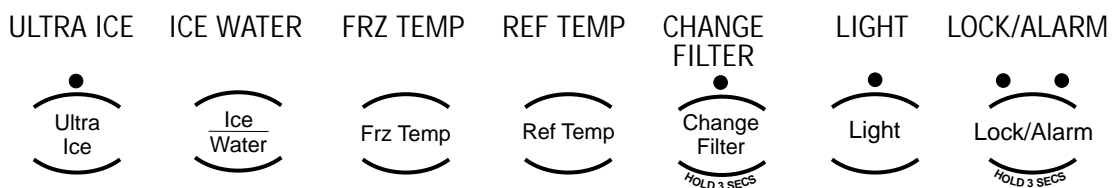

Figure 1.

\* It is acceptable if the adjusted level of water is a bit smaller than optimum level.

# 4. MICOM FUNCTION

## 1. Monitor Panel



### 1. FUNCTION

#### 1-1 Function

1. When the appliance is plugged in, it is set to 37°F for Refrigerator and 0°F for freezer.  
You can adjust the Refrigerator and the Freezer control temperature by pressing the ADJUST button.
2. When the power is initially applied or restored after a power failure, it is set to Control temperature Previously.



#### 1-2 How to Toggle the Display between °F & °C

1. The initial setting is °F and the display temperature mode can be changed from °F to °C or °C to °F by pressing and holding the FRZ TEMP and the REF TEMP keys at the same time for over 5 seconds.

### 1-3 Lock function (dispenser and display button lock)

1. When the refrigerator is first turned on, the buttons are not locked. The lock indicator light is turn OFF
2. To lock the display, the dispenser, and the control panel, press and hold the LOCK button for 3 seconds. The lock indicator Light is turn ON
3. The LOCK button is the only control feature that remains active in the locked state. The buzzer sound, other control buttons, and the dispenser are deactivated.
4. To release from the locked state, press and hold the LOCK button again for 3 seconds.

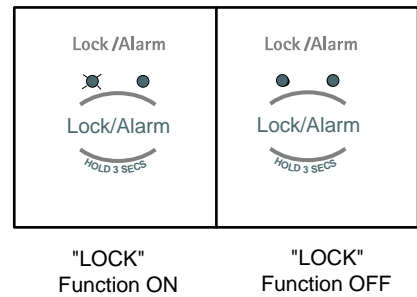

### 1-4 Filter condition display function

1. There is a replacement indicator light for the filter cartridge on the dispenser.
2. Water filter needs replacement once six months or of using water filter.
3. Water Filter icon turn on to tell you need to replace the filter soon.
4. After replacing the filter, press and hold the lock button more than 3 seconds. Water Filter icon turn off with reset status.

Classification	In initial Power On / Filter RESET	Replace indicator light on
Filter Status Display		

### 1-5 Ultra Ice selection

Please select this function for quick freezing.

- Function is repeat Ultra Ice Icon whenever pressing Ultra Ice button.
- Ultra Ice function automatically turns off after a fixed time passes.

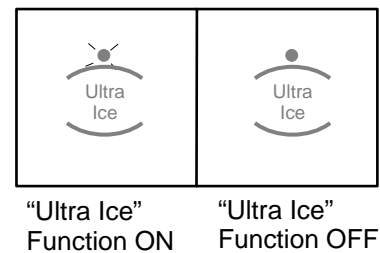

### 1-6 Dispenser use selection

You can select water or ice.

Select water, crushed ice, or ice cubes by cycling through the selections when pressing the DISPENSER button,

Hold your cup in the dispenser for a few seconds after dispensing ice or water to allow the last pieces of ice or drops of water to fall into the cup.

When after initially establishing the water comes out, the water tank inside fills and until at the time of quality the hour is caught.

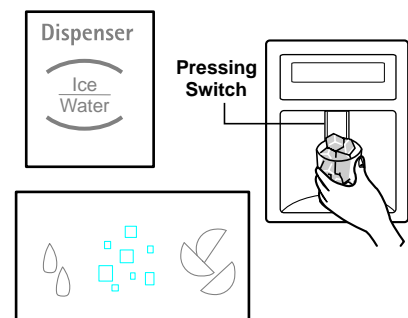

### 1-7 DISPENSER LIGHT

Please select this function for DISPENSER LIGHT MODE.

1. Normal status (LIGHT icon is OFF): When dispenser is operated, DISPENSER LIGHT is ON.
2. ON status (LIGHT icon is ON): DISPENSER LIGHT is on continuously

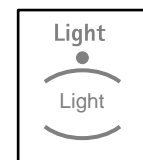

---

### **1-8 CONTROL OF FREEZER FAN MOTOR**

1. Freezer fan motor has high and standard speeds.
2. High speed is used at power-up, for Ultra Ice, and when refrigerator is overloaded.  
Standard speeds is used for general purposes.
3. To improve cooling speed, the RPM of the freezer fan motor change from normal speed to high.
4. High speed : Initial power on or load corresponding operation, Ultra Ice.  
Normal speed: Door open conditions.
5. Fan motor stops when refrigerator open.

### **1-9 Cooling Fan Motor**

1. The cooling fan is switched ON and OFF in conjunction with the compressor.
2. The cooling fan runs at a single speed.

### **1-10 Ultra Ice**

1. The purpose of this function is to intensify the cooling speed of freezer and to increase the amount of ice.
2. Whenever selection switch is pressed, selection/release, the LED will turn ON or OFF.
3. If there is a power outage and the refrigerator is powered on again, Ultra Ice will be canceled.
4. To activate this function, press the Ultra Ice key and the LED will turn ON. This function will remain activated for 24 hrs.  
The first three hours the compressor and Freezer Fan will be ON. The next 21 hours the freezer will be controlled at the lowest temperature. After 24 hours or if the Ultra Ice key is pressed again, the freezer will return to its previous temperature.
5. During the first 3 hours:
  - (1) Compressor and freezer fan (HIGH RPM) run continuously.
  - (2) If a defrost cycle begins during the first 90 minutes of Ultra Ice , the Ultra Ice cycle will complete its cycle after defrosting has ended.  
If the defrost cycle begins when Ultra Ice has run for more than 90 minutes, Ultra Ice will run for two hours after the defrost is completed.
  - (3) If Ultra Ice is pressed during defrost, Ultra Ice LED is on but this function will start seven minutes after defrost is completed and it shall operate for three hours.
  - (4) If Ultra Ice is selected within seven minutes after compressor has stopped, the compressor (compressor delays seven minutes) shall start after the balance of the delay time.
  - (5) The fan motor in the freezer compartment runs at high speed during Ultra Ice.
6. For the rest of the 21 hours, the freezer will be controlled at the lowest temperature.

### **1-11 REFRIGERATOR LAMP AUTO OFF**

1. To avoid heat damage caused by the lamp, it is turned off automatically when the refrigerator door is open for more than 7 Minutes.

### 1-13 Alarm for Open Door

1. This feature sounds a buzzer when the freezer or refrigerator door is not closed within 1 minute after it is opened.
2. One minute after the door is opened, the buzzer sounds three times each for 1/2 seconds. These tones repeat every 30 seconds.
3. The alarm is cancelled when the freezer or the refrigerator is closed while the buzzer sounds.

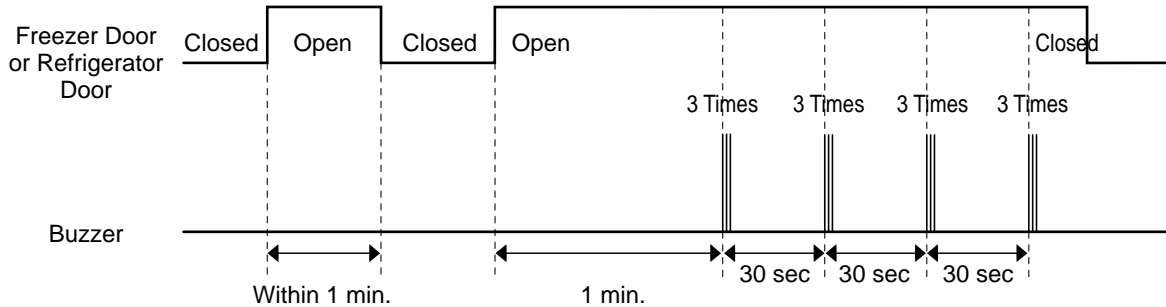

### 1-14 Defrosting (removing frost)

1. Defrosting starts each time the accumulated COMPRESSOR running time is between 7:00 and 50 hours. This time is determined by how often and how long the doors are opened.
2. For initial power on or for restoring power, defrosting starts when the compressor running time reaches 4 hours.
3. Defrosting stops if the sensor temperature reaches 41°F (5°C) or more. If the sensor doesn't reach 41°F (5°C) in 1 hour, the defrost mode is malfunctioning. (Refer to the defect diagnosis function, 8-1-15.)
4. Defrosting won't function if its sensor is defective (wires are cut or short circuited)

### 1-15 Defect Diagnosis Function

1. Automatic diagnosis makes servicing the refrigerator easy.
2. When a defect occurs, the buttons will not operate; but the tones, such as ding, will sound.
3. When defect is repaired the defect code is removed and refrigerator returns to normal operation (RESET).
4. The Defect code is shown on the Display.



LED check function: If simultaneously pressing Ultra Ice button and Frz Temp for a second, display LED graphics on. If releasing the button, the LED graphic displays the previous status.

## 1-16 Failure Diagnosis

### Error Code Diagnosis

- When an error occurs, the buttons will not operate; but the tones still sound.
- After the repair is made, it is necessary to replug in the refrigerator to reset to normal operation.

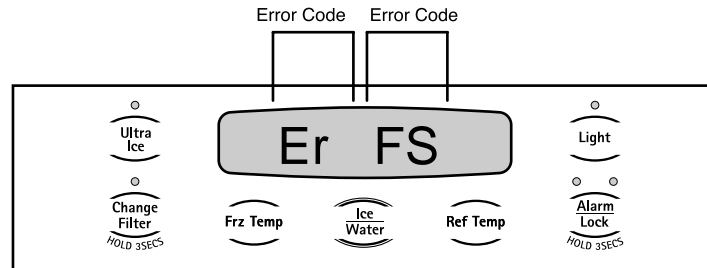

### ERROR CODE on display panel

ITEM	ERROR CODE		POSSIBLE CAUSES	PRODUCT OPERATION STATUS IN FAILURE				
	FREEZER ROOM NOTCH TEMPERATURE DISPLAY	REFRIGERATOR ROOM NOTCH TEMPERATURE DISPLAY		COMPRESSOR	FREEZING BLDC MOTOR	COOLING BLDC MOTOR	DEFROST HEATER	STEPPING MOTOR DAMPER
FREEZER SENSOR	Er	FS	FREEZER SENSOR SHORT / OPEN CIRCUIT	ON FOR 15 MINUTES / OFF FOR 15 MINUTES	STANDARD RPM	NORMAL OPERATION	NORMAL OPERATION	NORMAL OPERATION
REFRIGERATOR SENSOR1(R1) (UPPER PART IN THE REFRIGERATOR COMPARTMENT)	Er	rS	REFRIGERATOR (R1) SENSOR SHORT / OPEN CIRCUIT	NORMAL OPERATION	STANDARD RPM	NORMAL OPERATION	NORMAL OPERATION	FULL OPENING FOR 10 MINUTES/ FULL CLOSING FOR 15 MINUTES
DEFROST SENSOR	Er	dS	DEFROST SENSOR SHORT / OPEN CIRCUIT	NORMAL OPERATION	STANDARD RPM	NORMAL OPERATION	NO DEFROST	NORMAL OPERATION
DEFECTIVE DEFROST HEATER	Er	dH	DEFROST HEATER, TEMPERATURE FUSE OPEN, UNPLUGGED CONNECTOR	NORMAL OPERATION	STANDARD RPM	NORMAL OPERATION	NORMAL OPERATION	NORMAL OPERATION
FREEZING BLDC MOTOR	Er	FF	MOTOR DEFECTIVE, FAN BLADE OBSTRUCTED, SHORT / OPEN WIRE OF FAN MOTOR.	NORMAL OPERATION	OFF	NORMAL OPERATION	NORMAL OPERATION	NORMAL OPERATION
COOLING BLDC MOTOR	Er	CF	MOTOR DEFECTIVE, FAN BLADE OBSTRUCTED, SHORT / OPEN WIRE OF FAN MOTOR.	NORMAL OPERATION	STANDARD RPM	OFF	NORMAL OPERATION	NORMAL OPERATION
COMUNICATION BETWEEN PCB AND DISPLAY	Er	CO	SHORT OR OPEN OF LEAD WIRE CONNECTING BETWEEN MAIN PCB AND DISPLAY PCB	NORMAL OPERATION	STANDARD RPM	NORMAL OPERATION	NORMAL OPERATION	NORMAL OPERATION
AMBIENT SENSOR	NORMAL DISPLAY (SEE NOTE1)		AMBIENT SENSOR SHORT / OPEN CIRCUIT	NORMAL OPERATION	NORMAL OPERATION	NORMAL OPERATION	NORMAL OPERATION	NORMAL OPERATION
WATER-TANK SENSOR	NORMAL DISPLAY (SEE NOTE1)		WATER-TANK SENSOR SHORT / OPEN CIRCUIT	NORMAL OPERATION	NORMAL OPERATION	NORMAL OPERATION	NORMAL OPERATION	NORMAL OPERATION
REFRIGERATOR SENSOR2(R2) (LOWER PART IN THE REFRIGERATOR COMPARTMENT)	NORMAL DISPLAY (SEE NOTE1)		REFRIGERATOR (R2) SENSOR SHORT / OPEN CIRCUIT	NORMAL OPERATION	STANDARD RPM	NORMAL OPERATION	NORMAL OPERATION	NORMAL OPERATION

BY PRESSING AND HOLDING FREEZER TEMPERATURE ADJUST BUTTON AND ULTRA ICE BUTTON ALL LEDS ON THE CONTROL BOARD WILL LIGHT ON.

**NOTE 1:** THE BELOW ITEMS WILL NOT DISPLAY IN ERROR CODE, TO CHECK THIS ITEMS PRESS AND HOLD FREEZER TEMPERATURE ADJUST BUTTON AND ULTRA ICE BUTTON FOR AT LEAST ONE SECOND.

- R2-SENSOR (LOWER SENSOR IN REFRIGERATOR COMPARTMENT).....DEFECTIVE: “ULTRA ICE” INDICATOR WILL NOT BE LIT
- WATER TANK SENSOR .....DEFECTIVE: “LOCK” INDICATOR WILL NOT BE LIT
- AMBIENT SENSOR.....DEFECTIVE: “Er r”IS SHOWN IN THE DISPLAY

## 1-17 TEST Mode

1. The Test mode allows checking the PCB and the function of the product as well as finding out the defective part in case of an error.
2. The test mode is operated by pressing two buttons at Display panel.
3. While in the test mode, the function control button is not recognized, but the recognition tone sounds.
4. After exiting the test mode, be sure to reset by unplugging and then plugging in the appliance.
5. If an error, such as a sensor failure, is detected while in the test mode, the test mode is cleared and the error code is displayed.
6. While an error code is displayed, the test mode will not be activated.

### PCB TEST BUTTON FUNCTION

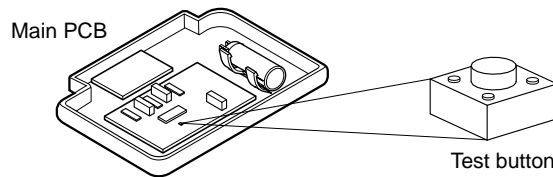

NOTE: Test mode will not begin if an error code is displayed

NOTE: During the Test mode, display board buttons will not operate.

- After finishing the Test mode, always unplug and replug in the refrigerator to reset to normal operation.

Mode	Operation	Function	Remarks
Test 1	Press test button once	<ul style="list-style-type: none"> <li>• Compressor on, Evaporator BLDC motor on and Condenser BLDC motor on.</li> <li>• Damper is completely opened.</li> <li>• All display LEDs or LCD Graphics turns on.</li> </ul>	Evaporator fan turns off if the door are open.
Test 2	Press the button again, to enter to Test 2.	<ul style="list-style-type: none"> <li>• Compressor off, Evaporator BLDC motor off and Condenser BLDC motor off.</li> <li>• Defrost heater turn on.</li> <li>• Damper is completely closed.</li> <li>• DISPLAY LED shows No. 22 22</li> </ul>	Return to the normal mode when the defrost sensor is above +41°F (5°C)
Normal Status	Press the button again, to return to Normal status.	Normal operation	Compressor will operate after delay for 7 minutes

### Demonstration MODE:

<p>Display shows the word OFF</p> <p>The image shows a close-up of the refrigerator's control panel. The display screen shows '0' on the left, 'FF' in the center, and 'FF' on the right. Below the display are several touch-sensitive buttons: Ultra Ice, Change Filter, Friz. Temp, Ice Water, Ref. Temp, Light, and Lock/Alarm.</p>	<p>The refrigerator control has been put into the store Demo (Demonstration) Mode. The Demonstration Mode disables the cooling system, only lamps and display work normally.</p> <p>To disable open one door, then press Ultra Ice and Ref. Temp buttons at the same time for 5 seconds. You will see the previous value setting you had on Display when Demo Mode is deactivated.</p>
---	--

1. Any door must be opened to enter in this mode.
2. When the Ultra Ice Button and the Ref Temp Button are pushed at same time and hold for 5 seconds or longer, it converts to Demonstration Mode "OFF".
3. The Display shows the Demo graphic. (The word "OFF" appears on the Display).
4. In this status, all Loads are "OFF" (Compressor, Damper, Fan, Heater).  
(Even is Demonstration Mode, Refrigerator Lamp automatic off function works normally and can be demonstrated).
5. Exit Demonstration Mode and reset Display by pressing the Ultra Ice Button and the Ref Temp Button for 5 seconds or longer. (With any door open).

# 5. CIRCUIT

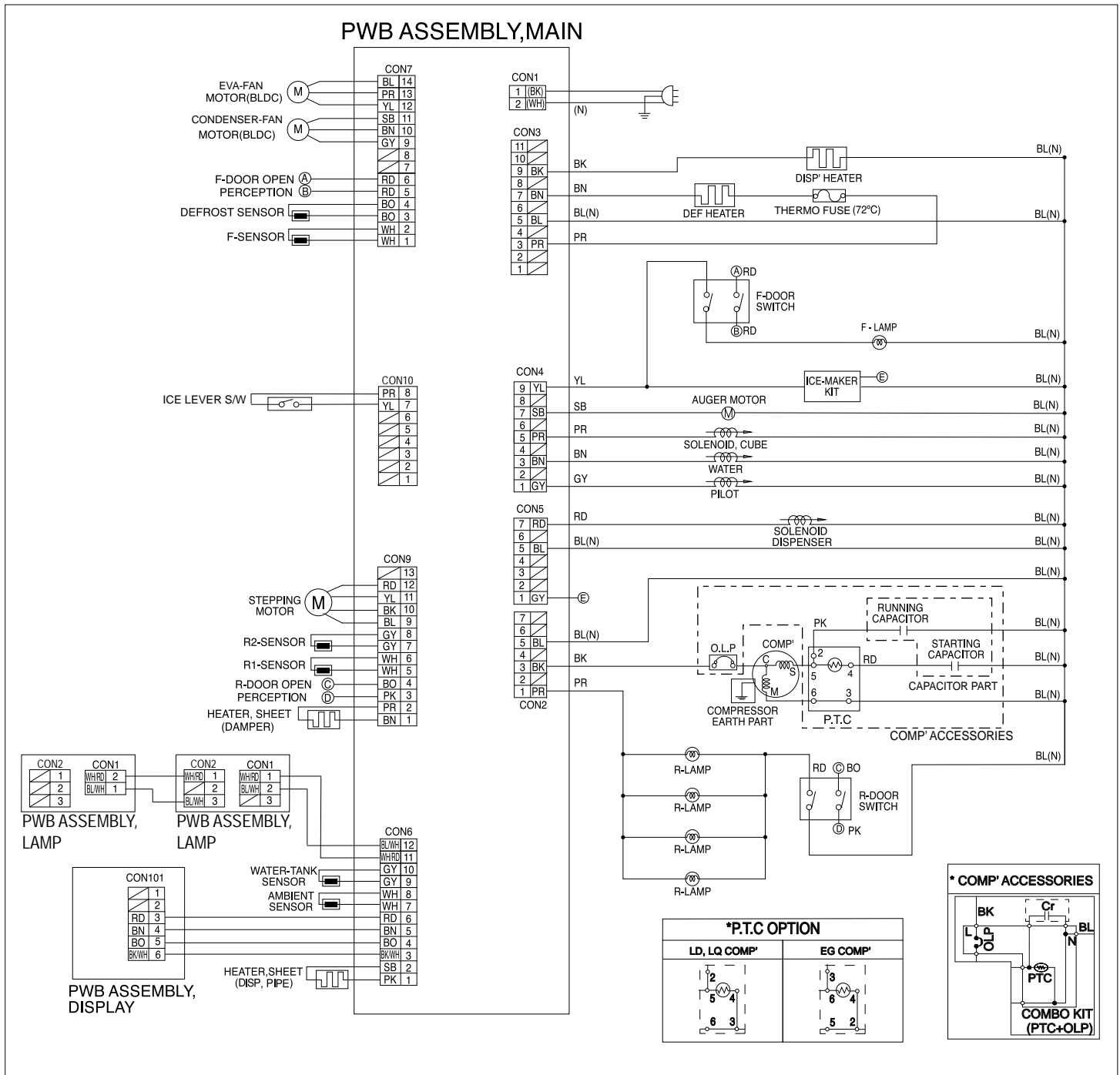



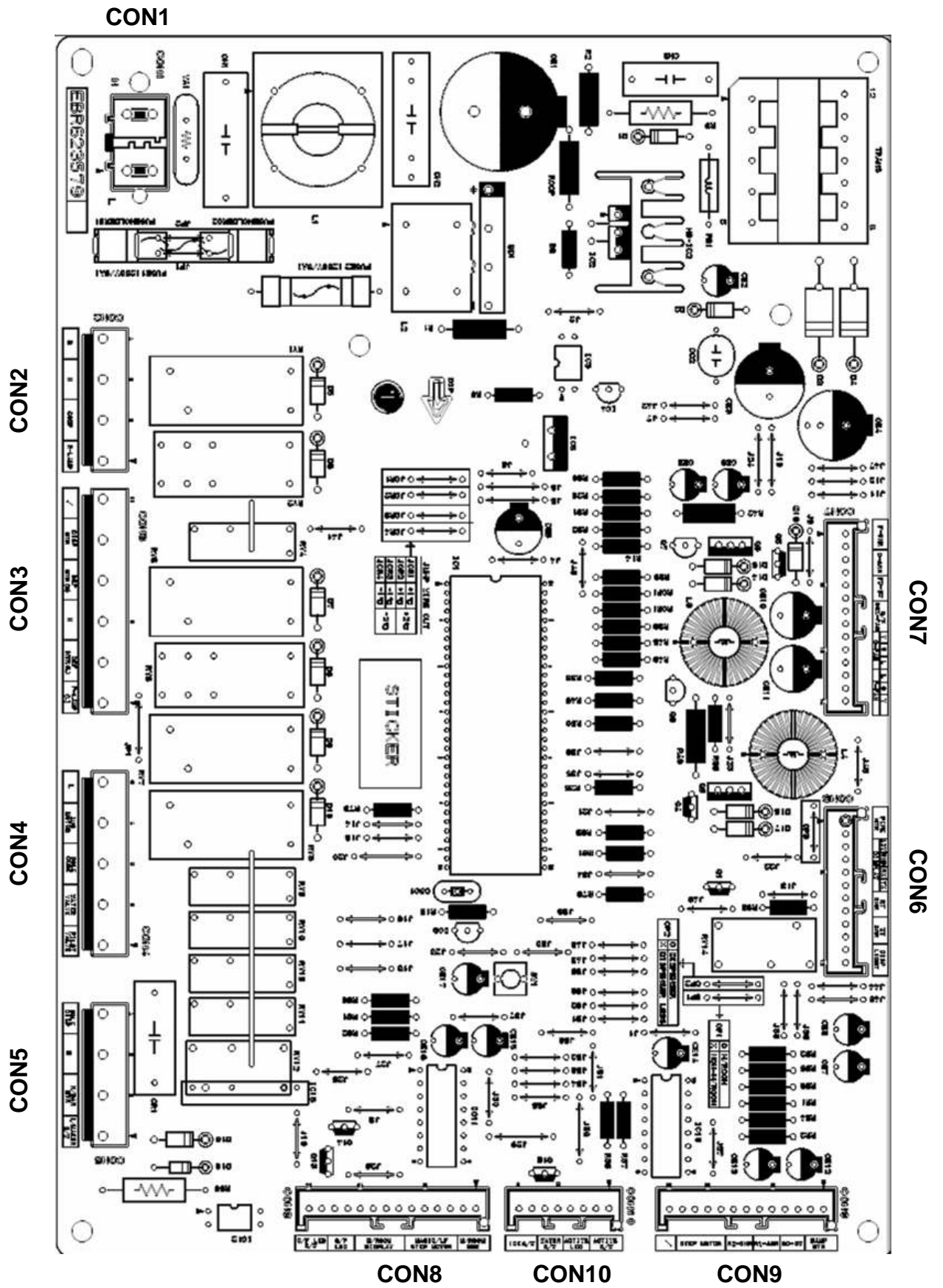

# 6.EXPLANATION FOR MICOM CIRCUIT

## 1. Explanation for PWB circuit

### 1-1. Power circuit

The power circuit includes a Switched Mode Power Supply (SMPS). It consists of a rectifier (BD1 and CE1) converting AC to DC, a switch (IC2) switching the DC voltage, a transformer, and a feedback circuit (IC3 and IC4).

Caution : Since high voltage (160 Vdc) is maintained at the power terminal, wait at least 3 minutes after unplugging the appliance to check the voltages to allow the current to dissipate.

Voltage of every part is as follows:

Part	VA1	CE1	CE2	CE3	CE4	CE5
Voltage	120 Vac	160 Vdc	14 Vdc	12 Vdc	15.5 Vdc	5 Vdc

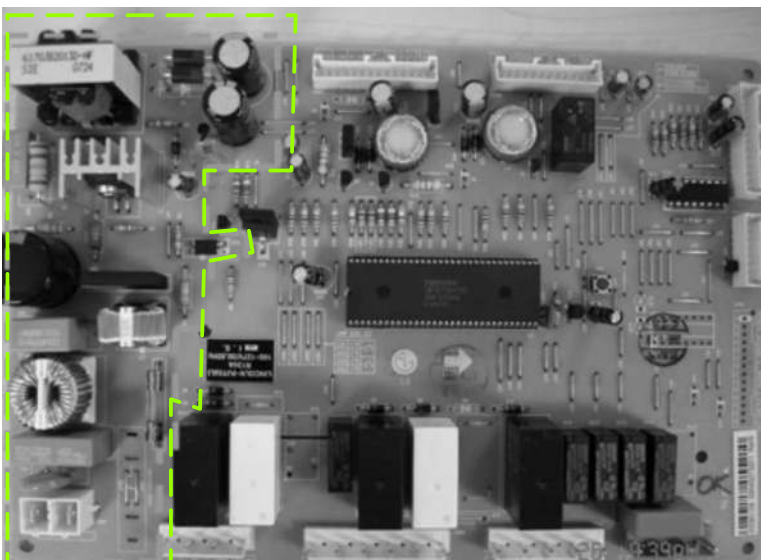
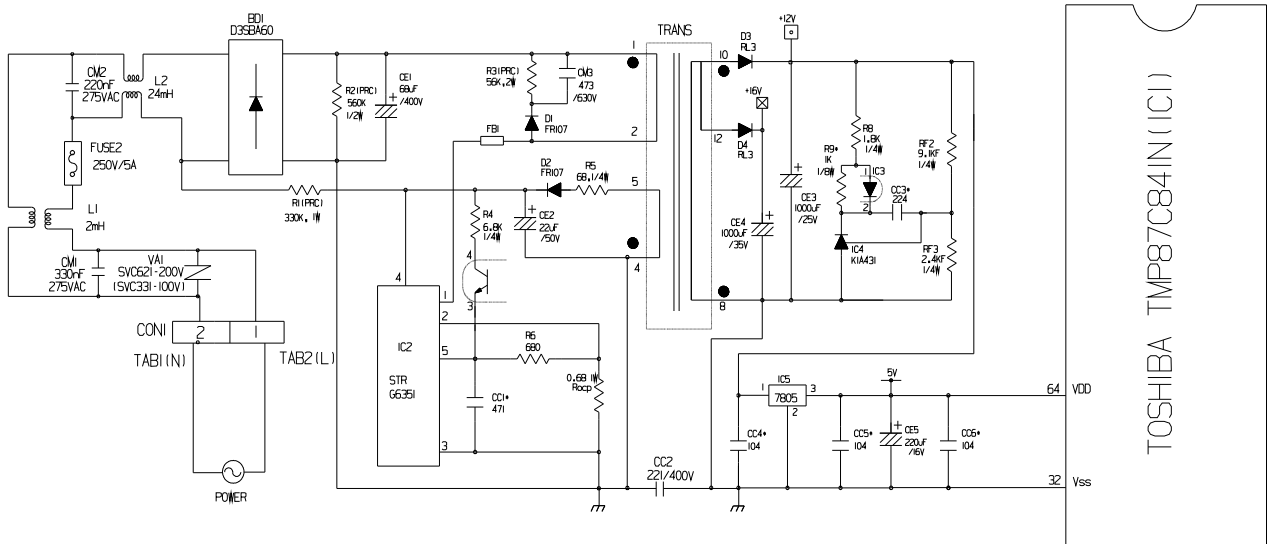

The part highlighted in green, are the components of the Switched Mode Power Supply

## 1-2. Load/dispenser operation, door opening circuit

### 1. LOAD DRIVING CIRCUIT

Type of Load	Compressor	Defrost Heater	Refrigerator LAMP	Dispenser Heater	Geared Motor	Solenoid Cube	Water	Pilot	Solenoid Dispenser
Measuring Part	CON2 PIN 3&5	CON3 PIN 3&7	CON2 PIN 1&7	CON3 PIN5&9	CON4 PIN 7 & CON5 PIN 5	CON4 PIN 5 & CON5 PIN 5	CON4 PIN 3 & CON5 PIN 5	CON4 PIN 1 & CON5 PIN 5	CON5 PIN 5&7
STATUS	ON	110~127VAC	110~127VAC	110~127VAC	110~127VAC	110~127VAC	110~127VAC	110~127VAC	110~127VAC
	OFF	0 VAC	0 VAC	0 VAC	0 VAC	0 VAC	0 VAC	0 VAC	0 VAC

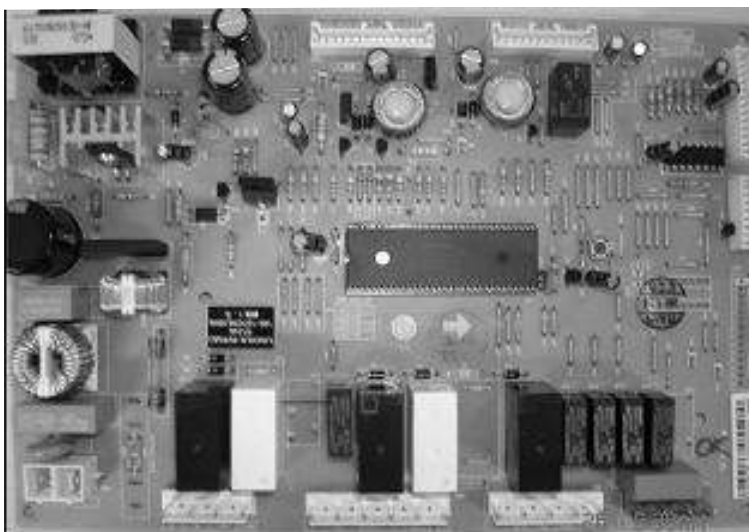
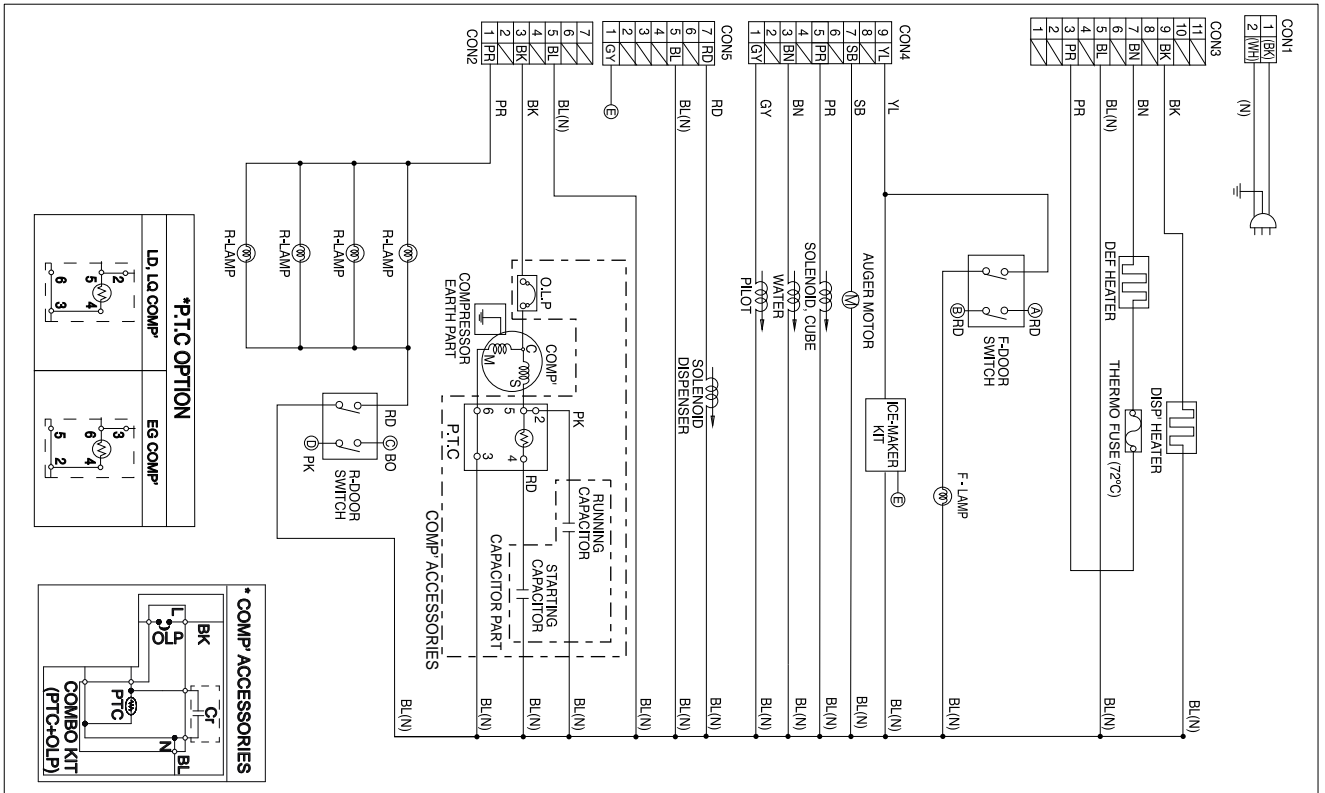

CON2

CON3

CON4

CON5

CON2

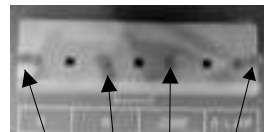

PIN 7 PIN 5 PIN 3 PIN 1

CON3

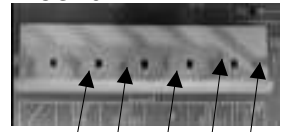

PIN 9 PIN 7 PIN 5 PIN 3 PIN 1

CON4

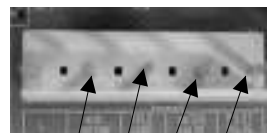

PIN 7 PIN 5 PIN 3 PIN 1

CON5

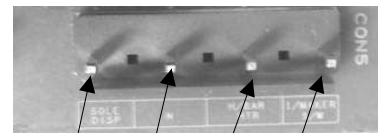

PIN 7 PIN 5 PIN 3 PIN 1

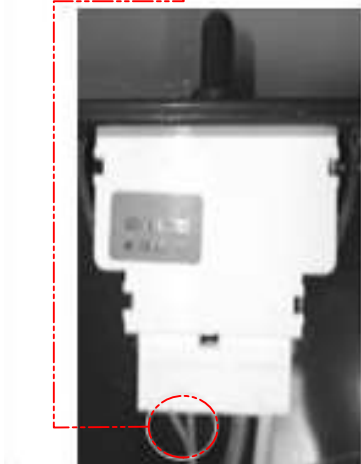
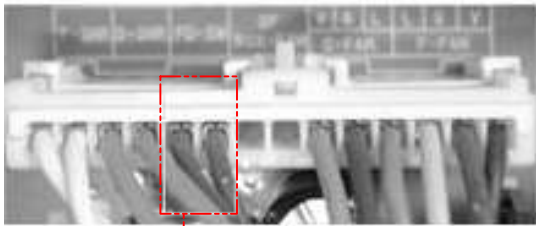
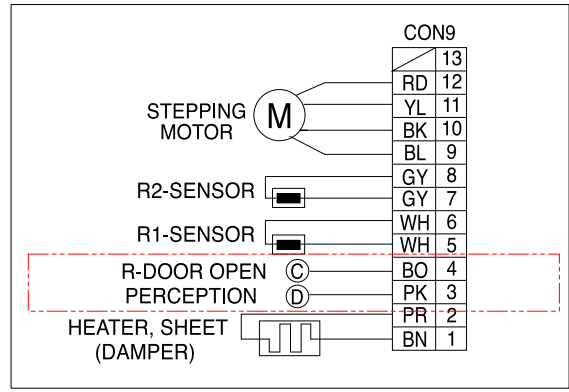
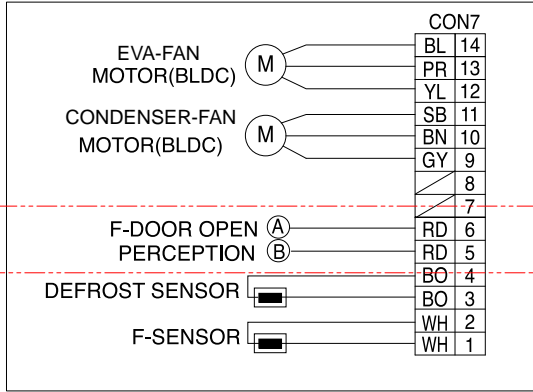

**CON7 (PIN5&6)**  
CONNECTOR 7  
F-DOOR S/W  
2\*RD  
PIN 5&6



**CON9 (PIN4&3)**  
CONNECTOR 9  
R-DOOR S/W  
BO, PK  
PIN 3&4

Measuring part	IC1 (MICOM) PIN 39, 40
<b>Door of Freezer / Refrigerator</b>	
Closing	5 V (A) - (B), (C) - (D) . Switch at both ends are at Off status)
Opening	0 V (A) - (B), (C) - (D) . Switch at both ends are at On status)

- Since door switches (A) and (B) are interconnected, if either fails, the other will not respond properly.
- If either switch fails, the light will not come on.

### 1-3 Temperature sensing circuit.

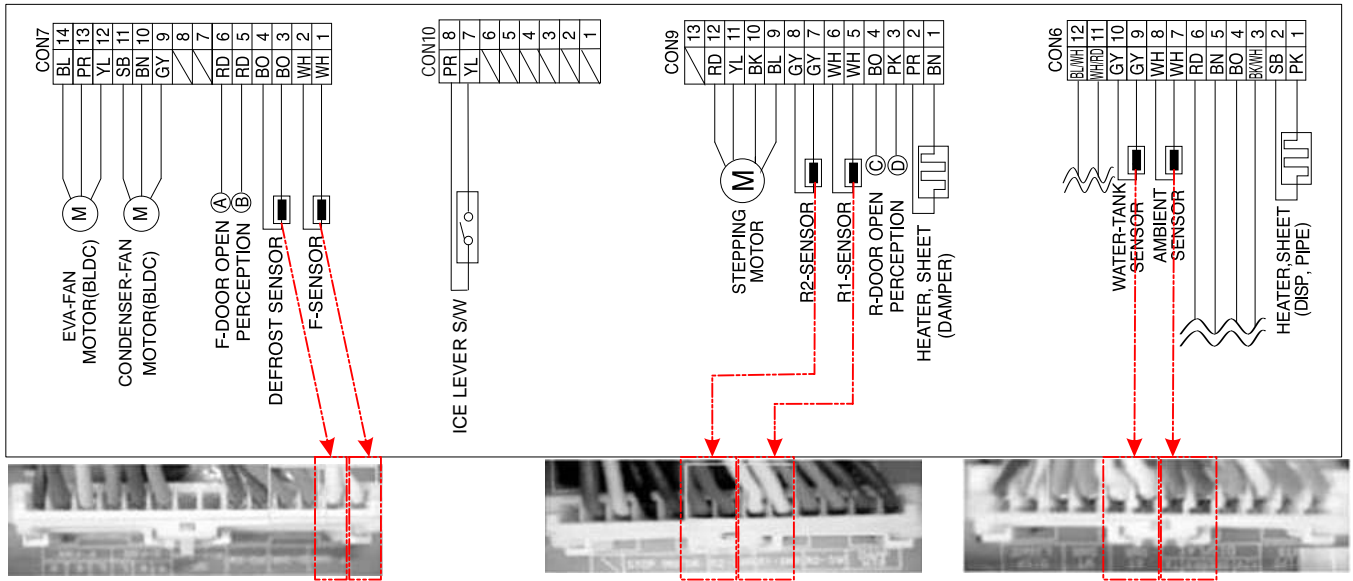

ITEM	SENSOR	LOCATION	COLOR
A	RT	CON6 PIN7,8	2*WH
B	WT	CON6 PIN9,10	2*GY
C	F	CON7 PIN1,2	2*WH
D	D	CON7 PIN3,4	2*BO
E	R1	CON9 PIN5,6	2*WH
F	R2	CON9 PIN7,8	2*GY

### 1-4 Switch entry circuit

The following circuit are sensing signal form the test switch , damper motor reed switch for testing and diagnosing the refrigerator.

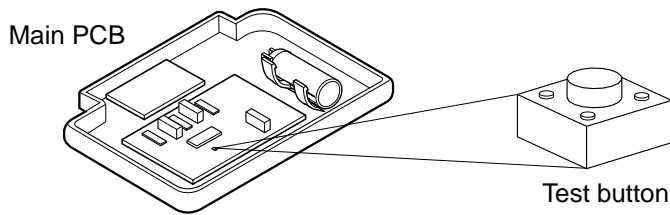

**1-5. Option designation circuit (model separation function)**

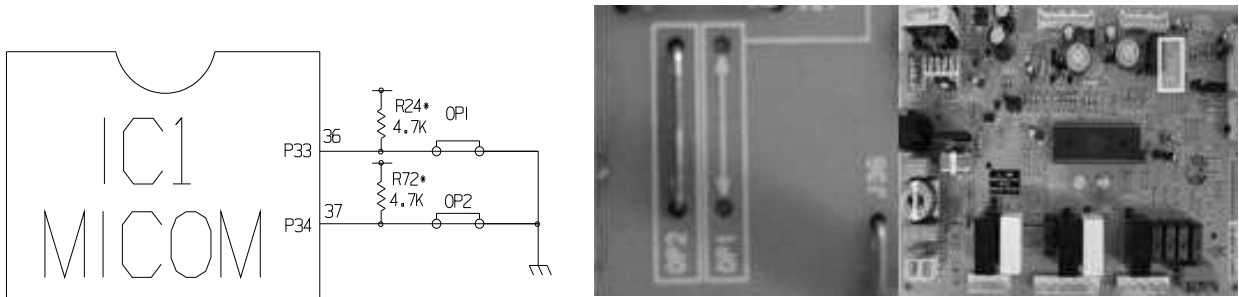

The circuit configuration is OP1 open and OP2 in short, these circuits are preset at the factory and can not be altered.

Separation	Connection Status	Application Standard
OP1	Short	M/Room
	Open	Non-M/Room
OP2	Short	Dispenser
	Open	Dispenser Less

**1-6. Stepping motor operation circuit**

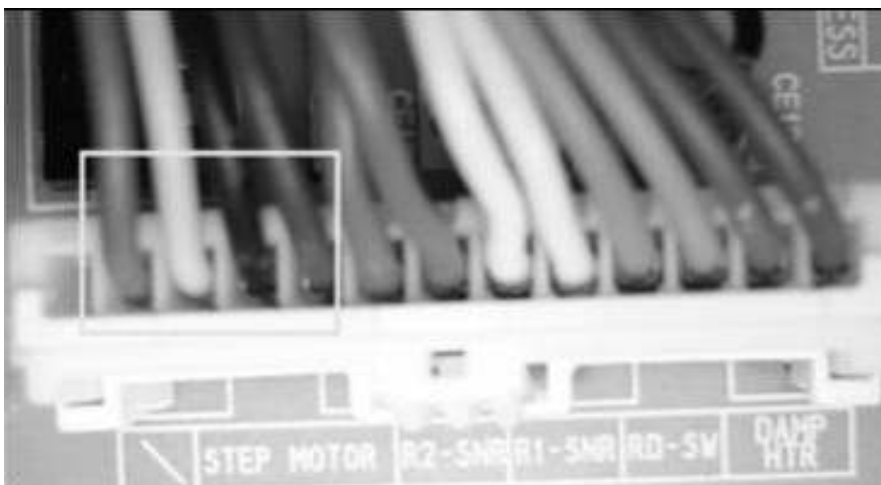
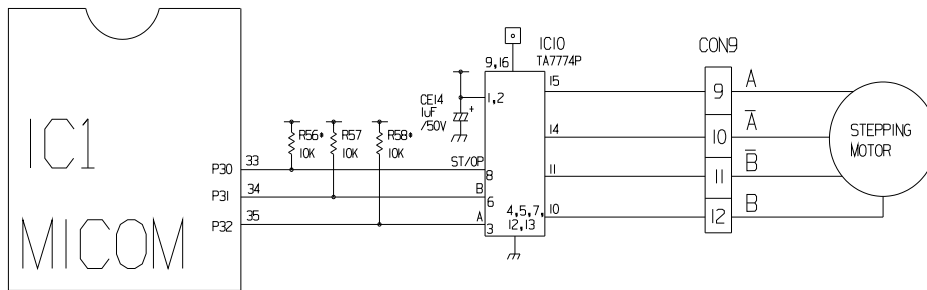

CONNECTOR 9  
 STEPPING MOTOR  
 PIN 9, 10, 11, 12  
 RD, YL, BK, BL

---

The motor is driven by magnetism formed in the areas of the coils and the stator. Rotation begins when a HIGH signal is applied to MICOM Pin 33 of IC10 (TA7774P). This causes an output of HIGH and LOW signals on MICOM pins 34 and 35.

**Explanation)** The stepping motor is driven by sending signals of 3.33 mSEC via MICOM pins 33, 34, and 35, as shown in the chart below. These signals are output via terminals 10, 11, 14, and 15 via input terminals 3, 6, and 8 of IC10 (TA7774P), the motor drive chip. The output signals allow the coils wound on each phase of the stator to form a magnetic field, which causes rotation. Input to the terminals INA and INB of IC10 as shown in the chart below drives the motor.

CCW (Reverse rotation) ←                      → (Positive rotation) CW

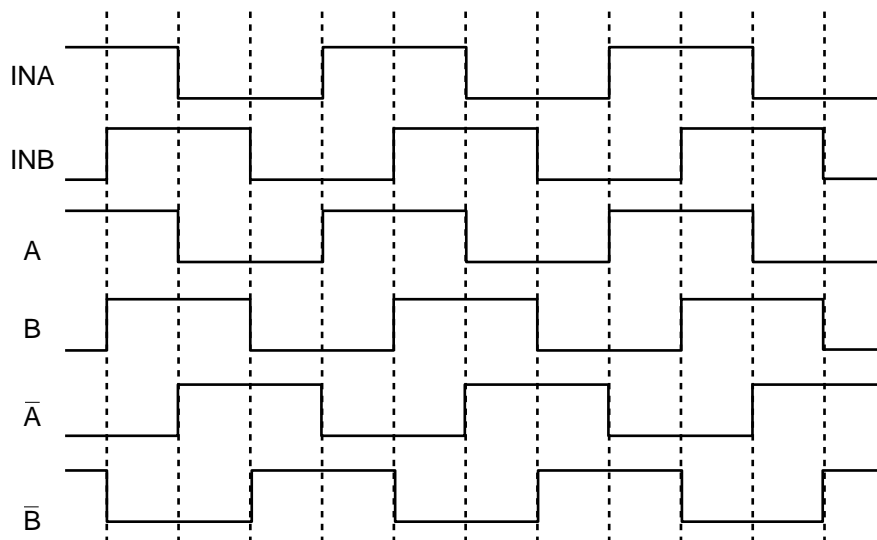

**1-7. Fan motor driving circuit (freezer, mechanical area)**

1. The circuit cuts all power to the fan drive IC, resulting in a standby mode.
2. This circuit changes the speed of the fan motor by varying the DC voltage between 7.5 Vdc and 16 Vdc.
3. This circuit stops the fan motor by cutting off power to the fan when it senses a lock-up condition.
4. The ground is connector 7, pin 2.

	Ⓐ, Ⓓ part	Ⓑ part	Ⓔ part
Motor OFF	5V	2V or less	2V or less
Motor ON	2 ~ 3V	12 ~ 14V	8 ~ 16V

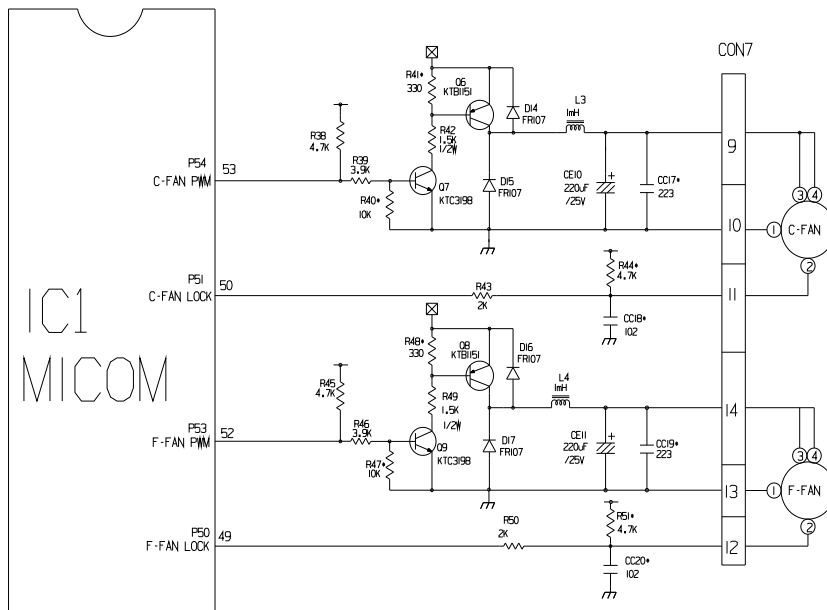

CON7	CON7
C-FAN	F-FAN
PIN 9, 10, 11	PIN 12, 13, 14
GY, BN, SB	YL, PR, BL



Temperature compensation table at the refrigerator is as follows:

	Modification resistance	470 Ω	2 kΩ	3.3 kΩ	5.6 kΩ	8.2 kΩ	10 kΩ	12 kΩ	18 kΩ	33 kΩ	56 kΩ	180 kΩ
	Current resistance											
Refrigerator (RCR1)	470Ω	No change	0.5 °C [0.9 °F] Up	1 °C [1.8 °F] Up	1.5 °C [2.7 °F] Up	2 °C [3.6 °F] Up	2.5 °C [4.5 °F] Up	3 °C [5.4 °F] Up	3.5 °C [6.3 °F] Up	4 °C [7.2 °F] Up	4.5 °C [8.1 °F] Up	5 °C [9 °F] Up
	2 kΩ	0.5 °C [0.9 °F] Down	No change	0.5 °C [0.9 °F] Up	1 °C [1.8 °F] Up	1.5 °C [2.7 °F] Up	2 °C [3.6 °F] Up	2.5 °C [4.5 °F] Up	3 °C [5.4 °F] Up	3.5 °C [6.3 °F] Up	4 °C [7.2 °F] Up	4.5 °C [8.1 °F] Up
	3.3 kΩ	1 °C [1.8 °F] Down	0.5 °C [0.9 °F] Down	No change	0.5 °C [0.9 °F] Up	1 °C [1.8 °F] Up	1.5 °C [2.7 °F] Up	2 °C [3.6 °F] Up	2.5 °C [4.5 °F] Up	3 °C [5.4 °F] Up	3.5 °C [6.3 °F] Up	4 °C [7.2 °F] Up
	5.6 kΩ	1.5 °C [2.7 °F] Down	1 °C [1.8 °F] Down	0.5 °C [0.9 °F] Down	No change	0.5 °C [0.9 °F] Up	1 °C [1.8 °F] Up	1.5 °C [2.7 °F] Up	2 °C [3.6 °F] Up	2.5 °C [4.5 °F] Up	3 °C [5.4 °F] Up	3.5 °C [6.3 °F] Up
	8.2 kΩ	2 °C [3.6 °F] Down	1.5 °C [2.7 °F] Down	1 °C [1.8 °F] Down	0.5 °C [0.9 °F] Drop	No change	0.5 °C [0.9 °F] Up	1 °C [1.8 °F] Up	1.5 °C [2.7 °F] Up	2 °C [3.6 °F] Up	2.5 °C [4.5 °F] Up	3 °C [5.4 °F] Up
	10 kΩ	2.5 °C [4.5 °F] Down	2 °C [3.6 °F] Down	1.5 °C [2.7 °F] Down	1 °C [1.8 °F] Down	0.5 °C [0.9 °F] Down	No change	0.5 °C [0.9 °F] Up	1 °C [1.8 °F] Up	1.5 °C [2.7 °F] Up	2 °C [3.6 °F] Up	2.5 °C [4.5 °F] Up
	12 kΩ	3 °C [5.4 °F] Down	2.5 °C [4.5 °F] Down	2 °C [3.6 °F] Down	1.5 °C [2.7 °F] Down	1 °C [1.8 °F] Down	0.5 °C [0.9 °F] Down	No change	0.5 °C [0.9 °F] Up	1 °C [1.8 °F] Up	1.5 °C [2.7 °F] Up	2 °C [3.6 °F] Up
	18 kΩ	3.5 °C [6.3 °F] Down	3 °C [5.4 °F] Down	2.5 °C [4.5 °F] Down	2 °C [3.6 °F] Down	1.5 °C [2.7 °F] Down	1 °C [1.8 °F] Down	0.5 °C [0.9 °F] Down	No change	0.5 °C [0.9 °F] Up	1 °C [1.8 °F] Up	1.5 °C [2.7 °F] Up
	33 kΩ	4 °C [7.2 °F] Down	3.5 °C [6.3 °F] Down	3 °C [5.4 °F] Down	2.5 °C [4.5 °F] Down	2 °C [3.6 °F] Down	1.5 °C [2.7 °F] Down	1 °C [1.8 °F] Down	0.5 °C [0.9 °F] Down	No change	0.5 °C [0.9 °F] Up	1 °C [1.8 °F] Up
	56 kΩ	4.5 °C [8.1 °F] Down	4 °C [7.2 °F] Down	3.5 °C [6.3 °F] Down	3 °C [5.4 °F] Down	2.5 °C [4.5 °F] Down	2 °C [3.6 °F] Down	1.5 °C [2.7 °F] Down	1 °C [1.8 °F] Down	0.5 °C [0.9 °F] Down	No change	0.5 °C [0.9 °F] Up
180 kΩ	5 °C [9 °F] Down	4.5 °C [8.1 °F] Down	4 °C [7.2 °F] Down	3.5 °C [6.3 °F] Down	3 °C [5.4 °F] Down	2.5 °C [4.5 °F] Down	2 °C [3.6 °F] Down	1.5 °C [2.7 °F] Down	1 °C [1.8 °F] Down	0.5 °C [0.9 °F] Down	No change	

Temperature compensation at the freezer is performed the same as at the refrigerator. The value for the freezer is twice that of the refrigerator.

This circuit enters the necessary level of temperature compensation for adjusting the appliance. The method is the same for every model in this appliance family.

2. Compensation circuit for temperature at freezer

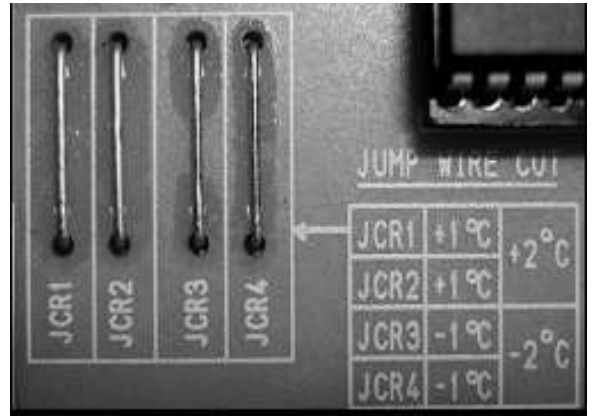
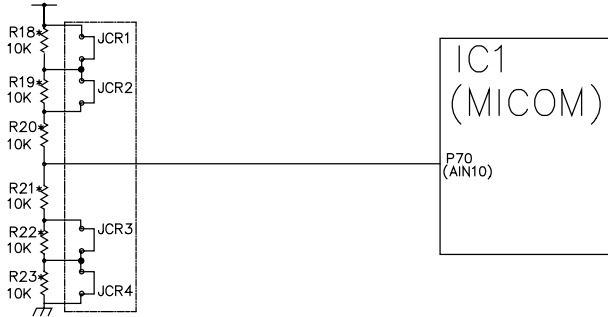

Temperature compensation in CUT		
JCR1	+1 °C [+1.8 °F]	+2 °C [+3.6 °F]
JCR2	+1 °C [+1.8 °F]	
JCR3	-1 °C [-1.8 °F]	-2 °C [-3.6 °F]
JCR4	-1 °C [-1.8 °F]	

Compensation for weak-cold		Compensation for over-cold		Temperature compensation value at refrigerator	Remarks
JCR3	JCR4	JCR1	JCR2		
<input type="checkbox"/>	<input type="checkbox"/>	<input type="checkbox"/>	<input type="checkbox"/>	0 °C (In shipment from factory)	
CUT	<input type="checkbox"/>	<input type="checkbox"/>	<input type="checkbox"/>	-1 °C [-1.8 °F]	
<input type="checkbox"/>	CUT	<input type="checkbox"/>	<input type="checkbox"/>	-1 °C [-1.8 °F]	
<input type="checkbox"/>	<input type="checkbox"/>	CUT	<input type="checkbox"/>	+1 °C [+1.8 °F]	
<input type="checkbox"/>	<input type="checkbox"/>	<input type="checkbox"/>	CUT	+1 °C [+1.8 °F]	
CUT	CUT	<input type="checkbox"/>	<input type="checkbox"/>	-2 °C [-3.6 °F]	
<input type="checkbox"/>	<input type="checkbox"/>	CUT	CUT	+2 °C [+3.6 °F]	
CUT	<input type="checkbox"/>	CUT	<input type="checkbox"/>	0 °C [0 °F]	
CUT	<input type="checkbox"/>	<input type="checkbox"/>	CUT	0 °C [0 °F]	
<input type="checkbox"/>	CUT	CUT	<input type="checkbox"/>	0 °C [0 °F]	
<input type="checkbox"/>	CUT	<input type="checkbox"/>	CUT	0 °C [0 °F]	
CUT	CUT	CUT	<input type="checkbox"/>	-1 °C [-1.8 °F]	
<input type="checkbox"/>	CUT	CUT	CUT	+1 °C [+1.8 °F]	
CUT	CUT	CUT	CUT	0 °C [0 °F]	

- This circuit allows adjustment of the set temperature for compensation by changing jumpers at locations JCR1~JCR4.

**1-8. Communication circuit and connection L/Wire between main PCB and display PCB**

The following communication circuit is used for exchanging information between the main MICOM of the Main PCB and the dedicated MICOM of the LED Display PCB.

A bi-directional lead wire assembly between the two boards is required for the display to function properly.

Poor communication occurs if a continuous information exchange fail to continue for more than 2 minutes between main MICOM of main PCB and LED dedicated MICOM for LED control of display PCB.

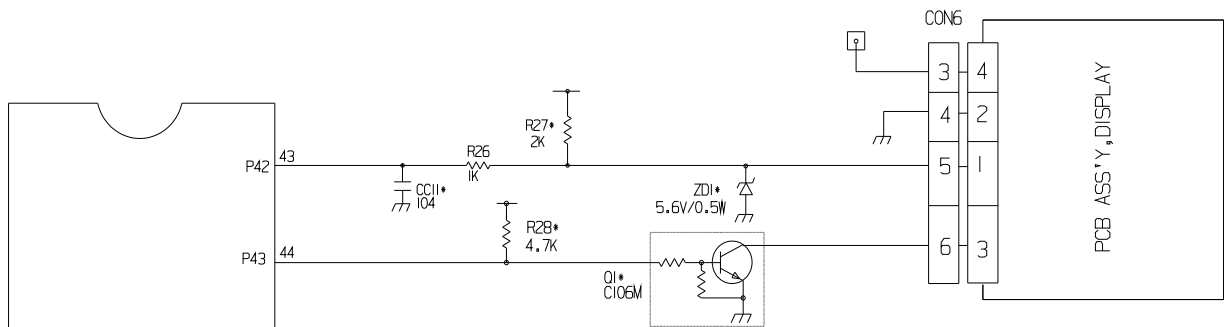
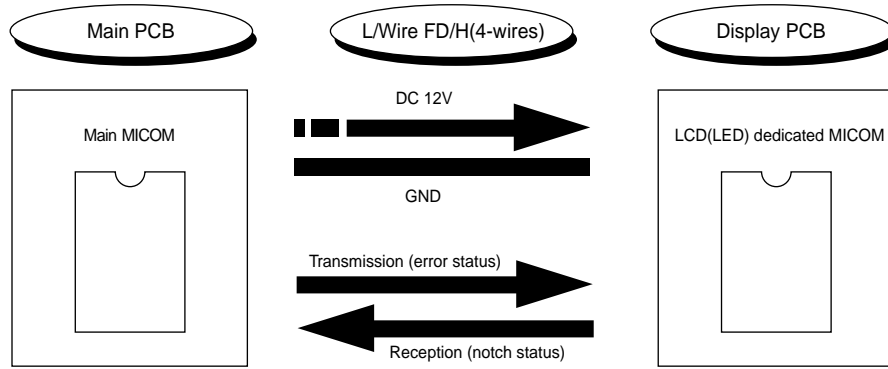

**1) Sensor resistance characteristics table**

<b>Measuring Temperature (°C)</b>	<b>Freezing Sensor</b>	<b>Cold storage sensor 1&amp;2 Frost removal sensor, Outside sensor</b>
-20 °C	22.3 kΩ	77 kΩ
-15 °C	16.9 kΩ	60 kΩ
-15 °C	13.0 kΩ	47.3 kΩ
-5 °C	10.1 kΩ	38.4 kΩ
0 °C	7.8 kΩ	30 k?
+5 °C	6.2 kΩ	24.1 kΩ
+10 °C	4.9 kΩ	19.5 kΩ
+15 °C	3.9 kΩ	15.9 kΩ
+20 °C	3.1 kΩ	13 k?
+25 °C	2.5 kΩ	11 kΩ
+30 °C	2.0 kΩ	8.9 kΩ
+40 °C	1.4 kΩ	6.2 kΩ
+50 °C	0.8 kΩ	4.3 kΩ

- Resistance value allowance of sensor is  $\pm 5\%$ .
- When measuring the resistance value of the sensor, allow the temperature of that sensor to stabilize for at least 3 minutes before measuring. This delay is necessary because of the sense speed relationship.
- Use a digital tester to measure the resistance. An analog tester has to great a margin of error.
- Resistance of the cold storage sensor 1 and 2 shall be measured with a digital tester
- Resistance of the freezing sensor shall be measured with a digital tester after separating CON7 of the PWB ASSEMBLY and the MAIN part.

# 7. ICEMAKER AND DISPENSER WORKING PRINCIPLES AND REPAIR

## 1. OPERATION PRINCIPLE

### 1-1. Operation Principle of Icemaker

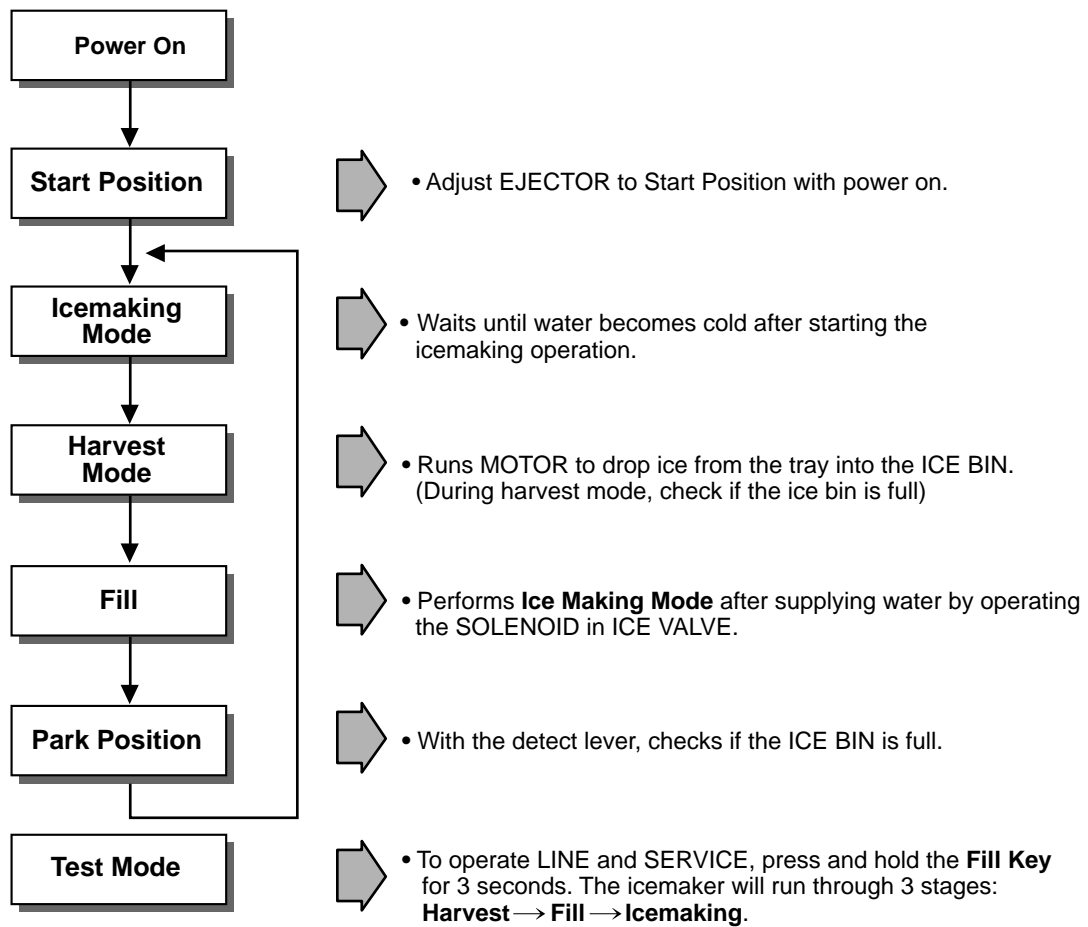

- Turning the Icemaker stop switch off (O) stops the ice making function.
- Setting the Icemaker switch to OFF and then turning it back on will reset the icemaker control.

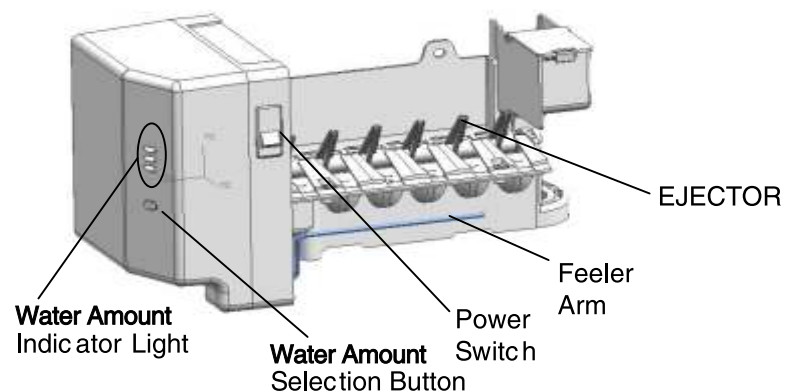

## 2. ICEMAKER FUNCTIONS

### 2-1. Start Position

1. After POWER OFF or power outage, check the EJECTOR's position with MICOM initialization to restart.
2. How to check if it is in place:
  - Check **HIGH/LOW** signals from HALL SENSOR in MICOM PIN.
3. Control Method to check if it is in place:
  - (1) EJECTOR is in place,
    - It is an initialized control, so the mode can be changed to icemaking mode.
  - (2) EJECTOR isn't in place:
    - A. If EJECTOR is back in place within 2 minutes with the motor on, it is being initialized. If not, go to Step B.
    - B. Control the heater using the temperature sensor until the EJECTOR reaches the correct location.

### 2-2. Icemaking Mode

1. Icemaking refers to the freezing of supplied water in the ice tray. Complete freezing is assured by measuring the temperature of the Tray with Icemaking SENSOR.
2. Icemaking starts after completion of the water fill operation.
3. The Ice Making function is completed when the sensor reaches 19°F (-7°C), 55 minutes after starting.
4. If the temperature sensor is defective, the ice-making function will be completed in 4 hours.

**NOTE :** After Icemaker Power is ON, the Icemaker heater will be on for test for 6 sec.

### 2-3. Harvest Mode



1. Harvest (Ice removing) refers to the operation of dropping ices into the ice bin from the tray when icemaking has completed.
2. Harvest mode:
  - (1) The Heater is ON for 30 seconds, then the motor starts.
  - (2) The feeler arm senses the quantity of ice in the ice storage bin while rotating with the EJECTOR.
    - A. Ice storage bin is full : The EJECTOR stops (heater off).
    - B. Ice storage bin is not full : The EJECTOR rotates twice to open for ice.

If the EJECTOR does not rotate once within 5 minutes in B mode, separate heater control mode starts operating to prevent the EJECTOR from being constrained. (It is recommended that the user open for ice to return to normal mode.)

### 2-4. Fill/Park position

1. Once a normal harvest mode has been completed, the water solenoid will be activated.
2. The amount of water is adjusted by pressing the Fill Key repeatedly. This changes the time allowed for fill as illustrated in the table below.





**Water supply amount TABLE**

STAGE	TIME TO SUPPLY	INDICATIONS	REMARKS
1	5 sec.		The water amount will vary depending on the water control switch setting, as well as the water pressure of the connected water line.
2	5.5 sec. (FIRST STAGE)		
3	6 sec.		

## 2-5. Function TEST

1. This is a forced operation for TEST, Service, cleaning, etc. It is operated by pressing and holding the Fill Key for 3 seconds.
2. The test works only in the Icemaking Mode. It cannot be entered from the Harvest or Fill mode. (If there is an ERROR, it can only be checked in the TEST mode.)
3. **Caution!** If the test is performed before water in the icemaker is frozen, the ejector will pass through the water. When the Fill mode begins (Stage 4), unless the water supply has been shut off, added water will overflow into the ice bin. If the control doesn't operate normally in the TEST mode, check and repair as needed.
4. After water is supplied, the normal CYCLE is followed: **icemaking** → **Harvest** → **Fill** → **Park Position**.
5. Five seconds after Stage 5 is completed, the Ice Maker returns to MICOM control. The time needed to supply water resets to the pre- test setting.

### Diagnosis TABLE

STAGE	ITEMS	INDICATOR	REMARKS
1	HEATER		Five seconds after heater starts, a heater will go off if the temperature by sensor is higher than 10°C
2	MOTOR		Five seconds after heater starts, you can confirm that a motor is moving.
3	HALL IC I (detection of position)		After the icemaker detects that ice has been made, the motor and heater are off but on standby until the cycle is cancelled.
4	HALL IC II (detection of position)		You can confirm HALL IC detection of position.
5	VALVE		Two seconds after detection of initial position, you can confirm that valve is on.
6	Reset	Return to Status prior to TEST MODE	Five seconds after fifth stage is completed, The icemaker resets to initial status.

## 3. DEFECT DIAGNOSIS FUNCTION

### 3-1. ERROR CODES shown on Icemaker water supply control panel

NO	DIVISION	INDICATOR	CONTENTS	REMARKS
1	Normal	Mark time to supply	None	Display switch operates properly
2	Icemaking Sensor malfunction		Open or short-circuited wire	Make sure that the wire on each sensor is connected.

ERROR indicators in table can be checked only in TEST mode.

# 8. TROUBLE DIAGNOSIS

## 1. TroubleShooting

CLAIMS.	CAUSES AND CHECK POINTS.	HOW TO CHECK
<p>1. Faulty start</p>	<p>1) No power at outlet.</p> <p>2) No power on cord.</p> <ul style="list-style-type: none"> <li>- Bad connection between adapter and outlet. (faulty adapter)               <ul style="list-style-type: none"> <li>- The Inner diameter of adapter.</li> <li>- The distance between holes.</li> <li>- The distance between terminals.</li> <li>- The thickness of terminal.</li> </ul> </li> <li>- Bad connection between plug and adapter (faulty plug).               <ul style="list-style-type: none"> <li>- The distance between pins.</li> <li>- Pin outer diameter.</li> </ul> </li> </ul> <p>3) Shorted start circuit.</p> <ul style="list-style-type: none"> <li>- No power on power cord.               <ul style="list-style-type: none"> <li>- Disconnected copper wire.                   <ul style="list-style-type: none"> <li>- Power cord is disconnected.</li> <li>- Faulty soldering.</li> </ul> </li> <li>- Internal electrical short.</li> <li>- Faulty terminal contact.                   <ul style="list-style-type: none"> <li>- Loose contact.                       <ul style="list-style-type: none"> <li>- Large distance between male terminal.</li> <li>- Thin female terminal.</li> </ul> </li> <li>- Terminal disconnected.</li> <li>- Bad sleeve assembly.</li> </ul> </li> <li>- Disconnected.                   <ul style="list-style-type: none"> <li>- Weak connection.</li> <li>- Short inserted cord length.</li> <li>- Worn out tool blade.</li> </ul> </li> </ul> </li> <li>- COMBO is off.               <ul style="list-style-type: none"> <li>- Capacity of COMBO is small.</li> <li>- Characteristics of COMBO is wrong.</li> <li>- Bad connection.</li> <li>- Power is disconnected.                   <ul style="list-style-type: none"> <li>- Inner Ni-Cr wire blows out.</li> <li>- Bad internal connection.</li> <li>- Faulty terminal caulking (Cu wire is cut).</li> <li>- Bad soldering.</li> </ul> </li> </ul> </li> <li>- No electric power on compressor. - Faulty compressor.</li> <li>- Faulty COMBO               <ul style="list-style-type: none"> <li>- Power does not conduct. - Damage.</li> <li>- Characteristics of COMBO is wrong</li> <li>- Bad connection with compressor.                   <ul style="list-style-type: none"> <li>- Too loose.</li> <li>- Assembly is not possible.</li> </ul> </li> <li>- Bad terminal connection.</li> </ul> </li> </ul> <p>4) During defrost.         <ul style="list-style-type: none"> <li>- Start automatic defrost.</li> <li>- Cycle was set at defrost when the refrigerator was produced.</li> </ul> </p>	<p>* Measuring instrument: Multi tester</p> <p>Check the voltage. If the voltage is within <math>\pm 85\%</math> of the rated voltage, it is OK.</p> <p>Check the terminal movement.</p> <p>Check both terminals of power cord. Power conducts:OK. No power conducts:NG</p> <p>Check rating of OLP OLP: 4TM437NFBYY Temp. 120°C If rating different: change it If not: OK</p> <p>Check the resistance of both terminals. Take the combo off and install it again.</p>



CLAIMS.	CAUSES AND CHECK POINTS.	HOW TO CHECK
2. No cooling.	<p>2) Refrigeration system is clogged.</p> <ul style="list-style-type: none"> <li>Moisture clogged. <ul style="list-style-type: none"> <li>Residual moisture in the evaporator. <ul style="list-style-type: none"> <li>Air Blowing. <ul style="list-style-type: none"> <li>Not performed.</li> <li>Too short.</li> <li>Impossible moisture confirmation.</li> <li>Low air pressure.</li> </ul> </li> <li>Leave it in the air. <ul style="list-style-type: none"> <li>During rest time.</li> <li>After work.</li> </ul> </li> <li>Caps are missed.</li> </ul> </li> <li>Residual moisture. <ul style="list-style-type: none"> <li>Not dried in the compressor.</li> <li>Elapsed more than 6 months after drying</li> <li>Caps are missed.</li> <li>No pressure when it is open.</li> </ul> </li> </ul> </li> <li>No electric power on thermostat. <ul style="list-style-type: none"> <li>Insufficient drier capacity. <ul style="list-style-type: none"> <li>Dry drier - Drier temperature.</li> <li>Leave it in the air. <ul style="list-style-type: none"> <li>Check on package condition.</li> <li>Good storage after finishing.</li> </ul> </li> </ul> </li> <li>Residual moisture in pipes. <ul style="list-style-type: none"> <li>Caps are missed. <ul style="list-style-type: none"> <li>During transportation.</li> <li>During work.</li> </ul> </li> <li>Air blowing. <ul style="list-style-type: none"> <li>Not performed.</li> <li>Performed. <ul style="list-style-type: none"> <li>Too short time.</li> <li>Low air pressure.</li> <li>Less dry air.</li> </ul> </li> </ul> </li> </ul> </li> <li>Moisture penetration - Leave it in the air. - Moisture penetration into the refrigeration oil.</li> </ul> </li> <li>Weld joint clogged. <ul style="list-style-type: none"> <li>Short pipe insert.</li> <li>Pipe gaps. <ul style="list-style-type: none"> <li>Too large.</li> <li>Damaged pipes.</li> </ul> </li> <li>Too much solder.</li> </ul> </li> <li>Drier clogging. <ul style="list-style-type: none"> <li>The capillary tube inserted depth. - Too much.</li> <li>Capillary tube melts. - Over heat.</li> <li>Clogged with foreign materials. <ul style="list-style-type: none"> <li>Desiccant powder.</li> <li>Weld oxides.</li> <li>Drier angle.</li> </ul> </li> <li>Reduced cross section by cutting. - Squeezed.</li> </ul> </li> <li>Foreign material clogging. <ul style="list-style-type: none"> <li>Compressor cap is disconnected.</li> <li>Foreign materials are in the pipe.</li> </ul> </li> </ul>	<ul style="list-style-type: none"> <li>Heat a clogged evaporator to check it. As soon as the cracking sound starts, the evaporator will begin to freeze.</li>   <li>The evaporator does not cool from the beginning (no evidence of moisture attached). The evaporator is the same as before even heat is applied.</li> </ul>

CLAIMS.	CAUSES AND CHECK POINTS.	HOW TO CHECK
<p>3. Refrigeration is weak.</p>	<p>1) Refrigerant Partly leaked. <span style="margin-left: 20px;">┌ Weld joint leak.</span>  <span style="margin-left: 40px;">└ Parts leak.</span></p> <p>2) Poor defrosting capacity.</p> <p style="margin-left: 20px;">┌ Drain path (pipe) clogged. <span style="margin-left: 20px;">┌ Inject adiabatics into drain</span>  <span style="margin-left: 40px;">└ Inject through the</span>  <span style="margin-left: 60px;">└ Seal with drain.</span></p> <p style="margin-left: 40px;">┌ Foreign materials <span style="margin-left: 20px;">┌ Adiabatics lump input.</span>  <span style="margin-left: 40px;">penetration. <span style="margin-left: 20px;">└ Damage by a screw or</span>  <span style="margin-left: 60px;">└ Other foreign materials input.</span></span></p> <p style="margin-left: 20px;">└ Cap drain is not disconnected.</p> <p style="margin-left: 20px;">┌ Defrost heater does not <span style="margin-left: 20px;">┌ Parts</span>  <span style="margin-left: 40px;">generate heat. <span style="margin-left: 20px;">└ disconnected.</span></span></p> <p style="margin-left: 40px;">┌ Plate <span style="margin-left: 20px;">┌ Wire is cut.</span>  <span style="margin-left: 40px;">heater <span style="margin-left: 20px;">└ Heating wire.</span>  <span style="margin-left: 60px;">└ Contact point</span>  <span style="margin-left: 80px;">└ between heating</span>  <span style="margin-left: 100px;">└ and electric wire.</span></span></p> <p style="margin-left: 40px;">└ Dent by fin evaporator.</p> <p style="margin-left: 40px;">└ Poor terminal contacts.</p> <p style="margin-left: 40px;">┌ Cord <span style="margin-left: 20px;">┌ Wire is cut.</span>  <span style="margin-left: 40px;">heater <span style="margin-left: 20px;">└ Lead wire.</span>  <span style="margin-left: 60px;">└ Heating wire.</span>  <span style="margin-left: 80px;">└ Contact point</span>  <span style="margin-left: 100px;">└ between heating and</span>  <span style="margin-left: 120px;">└ electric wire.</span></span></p> <p style="margin-left: 40px;">└ Heating wire is corroded</p> <p style="margin-left: 40px;">└ Water penetration.</p> <p style="margin-left: 40px;">└ Bad terminal connection.</p>	<ul style="list-style-type: none"> <li>• Check visually.</li>   <li>• Check terminal  Conduction: OK.  No conduction: NG.  If wire is not cut, refer to  resistance.  P=Power  V=Voltage  R=Resistance</li> </ul> $P = \frac{V^2}{R}$ $R = \frac{V^2}{P}$

CLAIMS.	CAUSES AND CHECK POINTS.	HOW TO CHECK
<p>3. Refrigeration is weak.</p>	<ul style="list-style-type: none"> <li>Residual frost. <ul style="list-style-type: none"> <li>Weak heat from heater. <ul style="list-style-type: none"> <li>Sheath Heater - rated.</li> <li>Heater plate <ul style="list-style-type: none"> <li>No contact to drain.</li> <li>Loosened stopper cord.</li> </ul> </li> <li>Heater cord-L <ul style="list-style-type: none"> <li>Not touching the evaporator pipe.</li> <li>Location of assembly (top and middle).</li> </ul> </li> </ul> </li> <li>Too short defrosting time. <ul style="list-style-type: none"> <li>Defrost Sensor. <ul style="list-style-type: none"> <li>- Faulty characteristics.</li> </ul> </li> <li>Seat-D (missing, location, thickness).</li> </ul> </li> <li>Structural fault. <ul style="list-style-type: none"> <li>Gasket gap.</li> <li>Air inflow through the fan motor.</li> <li>Bad insulation of case door.</li> </ul> </li> </ul> </li> <li>No automatic defrosting.</li> <li>Defrost does not return.</li> </ul> <p>3) Cooling air leak.</p> <ul style="list-style-type: none"> <li>Bad gasket adhesion <ul style="list-style-type: none"> <li>Gap.</li> <li>Bad attachment.</li> <li>Contraction.</li> </ul> </li> <li>Door sag. <ul style="list-style-type: none"> <li>Bad adhesion.</li> <li>Weak binding force at hinge.</li> </ul> </li> </ul> <p>4) No cooling air circulation.</p> <ul style="list-style-type: none"> <li>Faulty fan motor. <ul style="list-style-type: none"> <li>Fan motor. <ul style="list-style-type: none"> <li>Self locked.</li> <li>Wire is cut.</li> <li>Bad terminal contact.</li> </ul> </li> <li>Door switch. <ul style="list-style-type: none"> <li>Faults. <ul style="list-style-type: none"> <li>Contact distance.</li> <li>Button pressure.</li> <li>Melted contact.</li> <li>Contact.</li> </ul> </li> <li>Refrigerator and freezer switch reversed.</li> <li>Button is not pressed. <ul style="list-style-type: none"> <li>Poor door attachment.</li> <li>Door liner (dimension).</li> <li>Contraction inner liner.</li> <li>Misalignment.</li> <li>Bad terminal connection.</li> <li>Adiabatics liquid leak.</li> </ul> </li> </ul> </li> </ul> </li> </ul>	<ul style="list-style-type: none"> <li>• Check the fan motor conduction: OK.</li> <li>No conduction: NG.</li> </ul>

CLAIMS.	CAUSES AND CHECK POINTS.	HOW TO CHECK
<p>3. Refrigeration is weak.</p>	<p>4) No cooling air circulation.</p> <ul style="list-style-type: none"> <li>— Faulty fan motor. — Fan is constrained. <ul style="list-style-type: none"> <li>— Fan shroud contact. - Clearance.</li> <li>— Damping evaporator contact.</li> <li>— Accumulated residual frost.</li> </ul> </li> <li>— Small cooling air discharge. — Insufficient motor RPM <ul style="list-style-type: none"> <li>— Fan overload. - Fan misuse.</li> <li>— Bad low temperature RPM characteristics.</li> <li>— Rated power misuse.</li> <li>— Low voltage.</li> </ul> </li> <li>— Faulty fan. — Fan misuse. <ul style="list-style-type: none"> <li>— Bad shape.</li> <li>— Loose connection. - Not tightly connected.</li> <li>— Insert depth.</li> </ul> </li> <li>— Shroud. — Bent.</li> <li>— Ice and foreign materials on rotating parts.</li> </ul> <p>5) Compressor capacity. <ul style="list-style-type: none"> <li>— Rating misuse.</li> <li>— Small capacity.</li> <li>— Low voltage.</li> </ul> </p> <p>6) Refrigerant too much or too little. <ul style="list-style-type: none"> <li>— Malfunction of charging cylinder.</li> <li>— Wrong setting of refrigerant.</li> <li>— Insufficient compressor. - Faulty compressor.</li> </ul> </p> <p>7) Continuous operation <ul style="list-style-type: none"> <li>- No contact of temperature controller. - Foreign materials.</li> </ul> </p> <p>8) Damper opens continuously. <ul style="list-style-type: none"> <li>— Foreign materials jammed. <ul style="list-style-type: none"> <li>— Adiabatics liquid dump.</li> <li>— The EPS (styrofoam) drip tray has sediment in it.</li> <li>— A screw or other foreign material has fallen into the drip tray or damper.</li> </ul> </li> <li>— Failed sensor. - Position of sensor.</li> <li>— Characteristics of damper. <ul style="list-style-type: none"> <li>— Bad characteristics of its own temperatue.</li> <li>— Parts misuse.</li> <li>— Charge of temperature - Impact. characteristics.</li> </ul> </li> </ul> </p> <p>9) Food storing place. - Near the outlet of cooling air.</p>	<ul style="list-style-type: none"> <li>• Check visually after disassembly.</li> <li>• Check visually after disassembly.</li> </ul>

CLAIMS.	CAUSES AND CHECK POINTS.	HOW TO CHECK
<p>4. Warm refrigerator compartment temperature.</p> <p>5. No automatic operation. (faulty contacts)</p>	<p>1) Colgged cooling path.</p> <ul style="list-style-type: none"> <li>└ Adiabatics liquid leak.</li> <li>└ Foreign materials. — Adiabatics dump liquid.</li> </ul> <p>2) Food storate.</p> <ul style="list-style-type: none"> <li>└ Store hot food.</li> <li>└ Store too much at once.</li> <li>└ Door open.</li> <li>└ Packages block air flow.</li> </ul> <p>1) Faulty temperature sensor in freezer or refrigerator compartment.</p> <ul style="list-style-type: none"> <li>└ Faulty contact.</li> <li>└ Faulty temperature characteristics.</li> </ul> <p>2) Refrigeration load is too much.</p> <ul style="list-style-type: none"> <li>└ Food. <ul style="list-style-type: none"> <li>└ Too much food.</li> <li>└ Hot food.</li> </ul> </li> <li>└ Frequent opening and closing.</li> <li>└ Cool air leak.</li> <li>└ Poor door close. — Partly opens.</li> </ul> <p>3) Poor insulation.</p> <p>4) Bad radiation.</p> <ul style="list-style-type: none"> <li>└ High ambient temperature.</li> <li>└ Space is secluded.</li> </ul> <p>5) Refrigerant leak.</p> <p>6) Inadequate of refrigerant.</p> <p>7) Weak compressor discharging power.</p> <ul style="list-style-type: none"> <li>└ Different rating.</li> <li>└ Small capacity.</li> </ul> <p>8) Fan does not work.</p> <p>9) Button is set at strong .</p>	<ul style="list-style-type: none"> <li>• Inspect parts measurements and check visually.</li> </ul>
<p>6. Condensation and ice formation.</p>	<p>1) Ice in freeezer compartment.</p> <ul style="list-style-type: none"> <li>└ External air inflow.— Bushing installed incorrectly.</li> <li>└ Door opens but not closes. <ul style="list-style-type: none"> <li>└ Weak door closing power.</li> <li>└ Stopper malfunction.</li> <li>└ Door sag.</li> <li>└ Food hinders door closing.</li> </ul> </li> <li>└ Gap around gasket. — Contraction, distortion, loose, door twisted, comer not fully inserted.</li> <li>└ Food vapor. — Storing hot food. — Unsealed food.</li> </ul> <p>2) Condensation in the refrigerator compartment.</p> <ul style="list-style-type: none"> <li>└ Door opens but not closes. <ul style="list-style-type: none"> <li>└ Insufficient closing.</li> <li>└ Door sag.</li> <li>└ Food hinders door closing.</li> </ul> </li> <li>└ Gasket gap.</li> </ul> <p>3) Condensation on liner foam.</p> <ul style="list-style-type: none"> <li>└ Cool air leak and transmitted. <ul style="list-style-type: none"> <li>└ Not fully filled. <ul style="list-style-type: none"> <li>└ Top table part.</li> <li>└ Out plate Ref/Lower part.</li> </ul> </li> <li>└ Flange gap. — Not sealed.</li> <li>└ Gasket gap.</li> </ul> </li> </ul>	

CLAIMS.	CAUSES AND CHECK POINTS.	HOW TO CHECK
<p>6. Condensation and ice formation.</p>	<p>4) Condensation on door.</p> <ul style="list-style-type: none"> <li>Condensation on the duct door. - Duct door heater is cut.</li> <li>Condensation on the dispense recess. <ul style="list-style-type: none"> <li>Recess Heater is cut.</li> <li>Duct door is open. / Foreign material clogging.</li> </ul> </li> <li>Condensation on the door surface. <ul style="list-style-type: none"> <li>Not fully filled. <ul style="list-style-type: none"> <li>Surface. } Liquid shortage.</li> <li>Corner. } Liquid leak.</li> </ul> </li> <li>Adiabatics liquid contraction.</li> </ul> </li> <li>Condensation on the gasket surface. <ul style="list-style-type: none"> <li>Bad wing adhesion. <ul style="list-style-type: none"> <li>Wing sag(lower part).</li> <li>Door liner shape mismatch.</li> </ul> </li> <li>Comer. <ul style="list-style-type: none"> <li>Too much notch.</li> <li>Broken.</li> </ul> </li> <li>Home Bar heater is cut.</li> </ul> </li> </ul> <p>5) Water on the floor.</p> <ul style="list-style-type: none"> <li>Condensation in the refrigerator compartment.</li> <li>Defrosted water overflows. — Clogged discharging hose.</li> <li>Discharging hose — Evaporation tray located at wrong place. location.</li> <li>Tray drip. <ul style="list-style-type: none"> <li>Damaged.</li> <li>Breaks, holes.</li> <li>Small Capacity.</li> </ul> </li> <li>Position of drain.</li> </ul>	
<p>7. Sounds</p>	<p>1) Compressor compartment operating sounds.</p> <ul style="list-style-type: none"> <li>Compressor sound inserted. <ul style="list-style-type: none"> <li>Sound from machine itself.</li> <li>Sound from vibration. <ul style="list-style-type: none"> <li>Restrainer.</li> <li>Bushing seat. <ul style="list-style-type: none"> <li>Too hard.</li> <li>Distorted.</li> <li>Aged.</li> <li>Burnt.</li> </ul> </li> <li>Stopper.—Bad Stopper assembly. <ul style="list-style-type: none"> <li>Not fit (inner diameter of stopper).</li> <li>Tilted.</li> <li>Not</li> </ul> </li> <li>Compressor base not connected.</li> <li>Bad welding compressor stand(fallen).</li> <li>Foreign materials in the compressor compartment.</li> </ul> </li> <li>COMBO sound — Chattering sound. Insulation paper vibration.</li> <li>Capacitor noise. Pipe sound. <ul style="list-style-type: none"> <li>Pipe contacts each other. .- Narrow interval.</li> <li>No vibration damper. <ul style="list-style-type: none"> <li>Damping Bushing-Q.</li> <li>Damping Bushing-S.</li> </ul> </li> <li>Capillary tube unattached.</li> </ul> </li> </ul> </li></ul>	

CLAIMS.	CAUSES AND CHECK POINTS.	HOW TO CHECK
7. Sounds	<p>1) Compressor compartment operating sounds.</p> <ul style="list-style-type: none"> <li>Transformer sound. <ul style="list-style-type: none"> <li>Its own fault. - Core gap.</li> <li>Bad connection. - Correct screw connection.</li> </ul> </li> <li>Drip tray vibration sound. <ul style="list-style-type: none"> <li>Bad assembly.</li> <li>Distortion.</li> <li>Foreign materials inside.</li> </ul> </li> <li>Back cover machine sound. <ul style="list-style-type: none"> <li>Bad connection.</li> <li>Partly damaged.</li> </ul> </li> <li>Condenser drain sound. <ul style="list-style-type: none"> <li>Not connected.</li> <li>Bad pipe caulking.</li> </ul> </li> </ul> <p>2) Freezer compartment sounds.</p> <ul style="list-style-type: none"> <li>Fan motor sound. <ul style="list-style-type: none"> <li>Normal operating sound.</li> <li>Vibration sound. <ul style="list-style-type: none"> <li>Aged rubber seat.</li> <li>Bad torque for assembling motor bracket.</li> </ul> </li> </ul> </li> <li>Sounds from fan contact. <ul style="list-style-type: none"> <li>Fan guide contact.</li> <li>Shroud burr contact.</li> <li>Damping evaporator contact.</li> <li>Residual frost contact. <ul style="list-style-type: none"> <li>Damaged heater cord.</li> <li>Narrow evaporator interval.</li> </ul> </li> </ul> </li> <li>Unbalance fan sounds. <ul style="list-style-type: none"> <li>Unbalance. <ul style="list-style-type: none"> <li>Surface machining conditions.</li> <li>Fan distortion.</li> <li>Misshappen.</li> <li>Burr.</li> </ul> </li> <li>Ice on the fan. - Air intake (opposite to motor bushing assembly)</li> </ul> </li> <li>Motor shaft contact sounds. <ul style="list-style-type: none"> <li>Supporter disorted.</li> <li>Tilted during motor assembly.</li> </ul> </li> <li>Resonance.</li> <li>Evaporator noise. <ul style="list-style-type: none"> <li>Evaporator pipe contact. - No damping evaporator.</li> <li>Sound from refrigerant. - Stainless steel pipe shape in accumulator.</li> <li>Sound from fin evaporator and pipe during expansion and contraction.</li> </ul> </li> </ul> <p>3) Bowls and bottles make contact on top shelf.</p> <p>4) Refrigerator roof contact.</p> <p>5) Refrigerator side contact.</p> <p>6) Insufficient lubricants on door hinge.</p>	

CLAIMS.	CAUSES AND CHECK POINTS.	HOW TO CHECK
8. Faulty lamp (freezer and refrigerator compartment).	<p>1) Lamp problem. — Filament blows out. — Glass is broken.</p> <p>2) Bad lamp assembly. — Not inserted. — Loosened by vibration.</p> <p>3) Bad lamp socket.</p> <ul style="list-style-type: none"> <li>— Disconnection. — Bad soldering. — Bad rivet contact.</li> <li>— Short. — Water penetration. — Low water level in tray.</li> <li>— Bad elasticity of contact.</li> <li>— Bad contact (corrosion).</li> </ul> <p>4) Door switch. — Defective. — Refrigerator and freezer switches are reversed. — Travel distance. — Bad connection. — Bad terminal contact. — Adiabatics liquid leak..</p>	
9. Faulty internal voltage (short).	<p>1) Lead wire is damaged.</p> <ul style="list-style-type: none"> <li>— Wire damage when assembling Bracket Cover.</li> <li>— Outlet burr in the bottom plate.</li> <li>— Pressed by cord heater. lead wire, evaporator pipe.</li> </ul> <p>2) Exposed terminal.</p> <ul style="list-style-type: none"> <li>— Compressor Compartment terminal. - Touching other components.</li> <li>— Freezer compartment terminal. - Touching evaporator pipe.</li> </ul> <p>3) Faulty parts.</p> <ul style="list-style-type: none"> <li>— Transformer. — Coil contacts cover. — Welded terminal parts contact cover.</li> <li>— Compressor. — Bad coil insulation.</li> <li>— Plate heater.</li> <li>— Melting fuse. — Sealing is broken. — Moisture penetration.</li> <li>— Cord heater. — Pipe damaged. — Moisture penetration. — Bad sealing.</li> <li>— Sheath heater.</li> </ul>	<ul style="list-style-type: none"> <li>• Connect conduction and non-conduction parts and check with tester.</li> <li>Conduction: NG.</li> <li>Resistance° : OK.</li> </ul>



CLAIMS.	CAUSES AND CHECK POINTS.	HOW TO CHECK
<p>10. Structure, appearance, and others.</p>	<p>1) Door foam.</p> <ul style="list-style-type: none"> <li>Sag. <ul style="list-style-type: none"> <li>Hinge loose <ul style="list-style-type: none"> <li>Bolt is loosened during transportation.</li> <li>Not tightly fastened.</li> <li>Screw worn out .</li> </ul> </li> <li>Weak gasket adhesion. <ul style="list-style-type: none"> <li>Adhesion surface.</li> </ul> </li> <li>Fixed tape. <ul style="list-style-type: none"> <li>Not well fixed.</li> </ul> </li> </ul> </li> <li>Noise during operation. <ul style="list-style-type: none"> <li>Hinge interference. <ul style="list-style-type: none"> <li>Bigger door foam.</li> <li>Hinge-Pin tilted-Poor flatness.</li> <li>No washer.</li> <li>No grease.</li> </ul> </li> </ul> </li> <li>Malfunction. <ul style="list-style-type: none"> <li>Not closed Refrigerator compartment is opened when freezer compartment is closed (faulty stopper). <ul style="list-style-type: none"> <li>Interference between door liner and inner liner. <ul style="list-style-type: none"> <li>Stopper worn out.</li> <li>Bad freezer compartment door assembly.</li> <li>No stopper.</li> </ul> </li> </ul> </li> </ul> </li> </ul> <p>2) Odor.</p> <ul style="list-style-type: none"> <li>Temperature of refrigerator compartment. <ul style="list-style-type: none"> <li>High. <ul style="list-style-type: none"> <li>Faulty damper control.</li> <li>Button is set atweak.</li> <li>Door is open (interference by food).</li> </ul> </li> </ul> </li> <li>Deodorizer. <ul style="list-style-type: none"> <li>No deodorizer.</li> <li>Poor capacity.</li> </ul> </li> <li>Food Storage. <ul style="list-style-type: none"> <li>Seal condition.</li> <li>Storage of fragrant foods.</li> <li>Long term storage.</li> </ul> </li> <li>Others. <ul style="list-style-type: none"> <li>Odors from cleaners or items which shroud not be stored in a refrigerator.</li> </ul> </li> </ul>	

## 2. Faults

### 2-1. Power

Problems	Causes	Checks	Measures
No power on outlet.	<ul style="list-style-type: none"> <li>- Power cord cut.</li> <li>- Faulty connector insertion.</li> <li>- Faulty connection between plug and adapter.</li> </ul>	<ul style="list-style-type: none"> <li>- Check the voltage with tester.</li> <li>- Check visually.</li> <li>- Check visually.</li> </ul>	<ul style="list-style-type: none"> <li>- Replace the components.</li> <li>- Reconnect the connecting parts.</li> <li>- Reconnect the connecting parts.</li> </ul>
Fuse blows out.	<ul style="list-style-type: none"> <li>- Short circuit by wrong connection.</li> <li>- Low voltage products are connected to high voltage.</li> <li>- Short circuit by insects.</li> <li>- Electricity leakage.</li> <li>- High voltage.</li> <li>- Short circuit of components (tracking due to moisture and dust penetration).</li> </ul>	<ul style="list-style-type: none"> <li>- Check the fuse with tester or visually.</li> <li>- Check the input volt are with tester (between power cord and products).</li> <li>- Check the resistance of power cord with tester (if it is <math>0\Omega</math>, it is shorted).</li> </ul>	<ul style="list-style-type: none"> <li>- Find and remove the cause of problem (ex. short, high voltage, low voltage).</li> <li>- Replace with rated fuse.</li> </ul>

### 2-2. Compressor

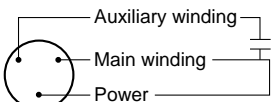
Problems	Causes	Checks	Measures
Compressor does not operate.	- Faulty Combo.	<ul style="list-style-type: none"> <li>- Check the resistance.</li> </ul> Value: $\infty$ is defective.	<ul style="list-style-type: none"> <li>- If resistance is infinite, replace with new one.</li> <li>- If it is not infinite, it is normal.</li> <li>- Check other parts.</li> </ul>
	- Compressor is frozen.	<ul style="list-style-type: none"> <li>- If compressor assembly parts are normal (capacitor, PTC, OLP), apply power directly to the compressor to force operation.</li> </ul>  <p>OLP It starts as soon as it is contacted.</p>	<ul style="list-style-type: none"> <li>- During forced operation:</li> <li>- Operates: Check other parts.</li> <li>- Not operate: Replace the frozen compressor with new one, weld, evacuate, and recharge refrigerator.</li> </ul> <ul style="list-style-type: none"> <li>• Refer to weld repair procedures</li> </ul>

### 2-3. Temperature

Problems	Causes	Checks	Measures
High temperature in the freezer compartment.	Poor cool air circulation due to faulty fan motor.	<ul style="list-style-type: none"> <li>- Lock — Check resistance with a tester. 0Ω: short. ∞Ω : cut.</li> <li>- Rotate rotor manually and check rotation.</li> <li>- Wire is cut.</li> <li>- Bad terminal contact: Check terminal visually.</li> <li>- Fan constraint. - Fan shroud contact: Confirm visually.</li> <li>- Fan icing: Confirm visually.</li> </ul>	<ul style="list-style-type: none"> <li>- Replace fan motor.</li> <li>- Reconnect and reinsert.</li> <li>- Maintain clearance and remove dust (Repair and/or replace shroud if fan is constrained by shroud deformation).</li> </ul>
	Faulty fan motor due to faulty door switch operation.	<ul style="list-style-type: none"> <li>- Iced button (faulty) operation: Press button to check</li> <li>- Faulty button pressure and contact: Press button to check operation.</li> <li>- Door cannot press door switch button: Check visually.</li> </ul>	<ul style="list-style-type: none"> <li>- Confirm icing causes and repair.</li> <li>- Replace door switch.</li> <li>- Door sag: fix door.</li> <li>- Door liner bent: replace door or attach sheets.</li> </ul>
	Bad radiation conditions in compressor compartment.	<ul style="list-style-type: none"> <li>- Check the clearance between the refrigerator and wall (50 mm in minimum).</li> <li>- Check dust on the grill in compressor compartment.</li> <li>- Check dust on the condenser coils.</li> </ul>	<ul style="list-style-type: none"> <li>- Keep clearance between refrigerator and walls (minimum 50mm).</li> <li>- Remove dust and contaminants from grill for easy heat radiation.</li> <li>- Remove the dust with vacuum cleaner from the coils condenser while the refrigerator is off.</li> </ul>

## 2-4. Cooling

Problems	Causes	Checks	Measures
High temperature in the freezer compartment.	Refrigerant leak.	<p><u>Check sequence</u></p> <ol style="list-style-type: none"> <li>1. Check the welded parts of the drier inlet and outlet and drier auxiliary in the compressor compartment (high pressure side).</li> <li>2. Check the end of compressor sealing pipe (low pressure side).</li> <li>3. Check silver soldered parts. (Cu + Fe / Fe + Fe).</li> <li>4. Check bending area of wire condenser pipe in compressor compartment (cracks can happen during bending).</li> <li>5. Check other parts (compressor compartment and evaporators in freezer compartment).</li> </ol>	Weld the leaking part, recharge the refrigerant.
	Shortage of refrigerant.	<p>Check frost formation on the surface of evaporator in the freezer compartment.</p> <ul style="list-style-type: none"> <li>- If the frost forms evenly on the surface, it is OK.</li> <li>- If it does not, it is not good.</li> </ul>	<ul style="list-style-type: none"> <li>- Find out the leaking area, repair, evacuate, and recharge the refrigerant.</li> <li>- No leaking, remove the remaining refrigerant, and recharge new refrigerant.</li> </ul>

<b>Problems</b>	<b>Causes</b>	<b>Checks</b>	<b>Measures</b>
High temperature in the freezer compartment.	Cycle pipe is clogged.	<p>Check sequence.</p> <p>1. Check temperature of condenser manually. If it is warm, OK. If it is not, compressor discharging joints might be clogged.</p> <p>2. Manually check whether hot line pipe is warm. If it is warm, OK. If it is not, condenser outlet weld joints might be clogged.</p>	<p>- Heat up compressor discharging weld joints with touch, disconnect the pipes, and check the clogging. Remove the causes of clogging, weld, evacuate, and recharge the refrigerant.</p> <p>- If it's warm, OK. If it's not, condenser discharging line weld joints might be clogged. Disconnect with torch, remove the causes, evacuate, and recharge seal refrigerant.</p>
	Leak at loop pipe weld joint (discharge) in compressor.	<p>Check sequence.</p> <p>1. Manually check whether condenser is warm, It is not warm and the frost forms partly on the evaporator in the freezer compartment.</p>	<p>Replace the compressor, weld, evacuate, and recharge refrigerant.</p>
	Faulty cooling fan in the compressor compartment.	<p>Check sequence.</p> <p>1. Check cooling fan operation.</p> <p>2. Check that cooling fan is disconnected from the motor.</p>	<p>- Replace if motor does not operate.</p> <p>- If fan is disconnected, check fan damage and reassemble it. Refer to fan motor disassembly and assembly sequence.</p>

## 2-5. Defrosting failure

Problems	Causes	Checks	Measures
No defrosting.	<p>Heater does not generate heat as the heating wire is cut or the circuit is shorted.</p> <p>1) Heating wire is damaged when inserting into the evaporator.</p> <p>2) Lead wire of heater is cut.</p> <p>3) Heating wire at lead wire contacts is cut.</p>	<p>1. Check the resistance of heater. 0Ω: Short. ∞Ω: Cut. Tens to thousands Ω: OK.</p> <p>2. Check the resistance between housing terminal and heater surface. 0Ω: Short. ∞Ω: Cut. Tens to thousands Ω: Short.</p>	<p>Heating wire is short and wire is cut.</p> <ul style="list-style-type: none"> <li>• Parts replacement: Refer to parts explanations.</li> </ul>
	<p>Suction tube and discharge orifice:</p> <p>1. Impurities.</p> <p>2. Ice.</p>	<p>1. Confirm foreign materials. In case of ice, insert the copper line through the hole to check.</p> <p>2. Put hot water into the drain (check drains outside).</p>	<p>1) Push out impurities by inserting copper wire. (Turn off more than 3 hours and pour in hot water if frost is severe.)</p> <p>2) Put in hot water to melt down frost.</p> <p>3) Check the water outlet.</p> <p>4) Push the heater plate to suction duct manually and assemble the disconnected parts.</p>
	<p>Gap between Suction duct and Heater plate (Ice in the gap).</p>	<p>1. Confirm in the Suction duct.</p>	<p>1) Turn off the power, confirm impurities and ice in the gap, and supply hot water until the ice in gap melts down.</p> <p>2) Push the Heater plate to drain bottom with hand and assemble the disconnected parts.</p>
	<p>Wrong heater rating (or wrong assembly).</p>	<p>1. Check heater label.</p> <p>2. Confirm the capacity after substituting the resistance value into the formula.</p> $P = \frac{V^2}{R}$ <p>(V: Rated voltage of user country) (R: Resistance of heater)</p> <p>Compare P and level capacity. Tolerance: ±7%</p>	<p>Faults: replace.</p> <p>- How to replace : Refer to main parts.</p>

Problems	Causes	Checks	Measures
No defrosting	Melting fuse blows. 1) Lead wire is cut. 2) Bad soldering.	- Check melting fuse with tester. - If $0\Omega$ : OK. If $\infty\Omega$ : wire is cut.	Faulty parts: parts replacement. - Check wire color when measuring resistance with a tester.
	Ice in the Suction duct. 1) Icing by foreign materials in the duct. 2) Icing by cool air inflow through the gap of heater plate. 3) Icing by the gap of heater plate.	1. Check the inner duct with mirror.  2. Check by inserting soft copper wire into the duct (soft and thin copper not to impair heating wire).	1) Turn power off. 2) Raise the front side (door side), support the front side legs, and the ice melt naturally. (If power on, melt the frost by forced defrosting.) 3) Reassemble the heater plate.
	Bad cool air inflow and discharge, and bad defrosting due to faulty contact and insertion (bad connector insertion into housing of heater, melting, fuse, and motor fan).	1. Turn on power, open or close the door, check that motor fan operates (If it operates, motor fan is OK). 2. Disconnect parts in the refrigerator compartment, check the connection around the housing visually, defrost, and confirm heat generation on the heater. Do not put hands on the sheath heater. 3. Check the parts which have faults described in 1 & 2 (mechanical model: disconnect thermostat from the assembly).	1) Check the faulty connector of housing and reassemble wrong assembled parts. 2) If the parts are damaged, remove the parts and replace it with a new one.

## 2-6. Icing

Problems	Causes	Checks	Measures
<p>Icing in the refrigerator compartment.</p> <ul style="list-style-type: none"> <li>- Damper icing.</li> <li>- Pipe icing.</li> <li>- Discharging pipe icing.</li> </ul>	<p>1) Bad circulation of cool air.</p> <ul style="list-style-type: none"> <li>- Clogged intake port in the refrigerator compartment.</li> <li>- Sealing is not good.</li> <li>- Too much food is stored and clogs the discharge port.</li> <li>- Bad defrosting.</li> </ul>	<ul style="list-style-type: none"> <li>- Check the food is stored properly (check discharge and intake port are clogged).</li> <li>- Check icing on the surface of baffle and cool air path (pipe) after disassembling the container box.</li> <li>- Check icing at intake ports of freezer and refrigerator compartment.</li> </ul>	<ul style="list-style-type: none"> <li>- Be acquainted with how to use.</li> <li>- Sealing on connecting parts.</li> <li>- Check the damper and replace it if it has defects.</li> <li>- Check defrost. (After forced defrosting, check ice in the evaporator and pipes.)</li> </ul>
	<p>2) Faulty door or refrigerator compartment.</p> <ul style="list-style-type: none"> <li>- Faulty gasket.</li> <li>- Faulty assembly.</li> </ul>	<ul style="list-style-type: none"> <li>- Check gasket attached conditions.</li> <li>- Check door assembly conditions.</li> </ul>	<ul style="list-style-type: none"> <li>- Correct the gasket attachment conditions and replace it.</li> <li>- Door assembly and replacement</li> </ul>
	<p>3) Overcooling in the refrigerator compartment.</p> <ul style="list-style-type: none"> <li>- Faulty damper in the refrigerator compartment.</li> <li>- Faulty MICOM (faulty sensor)</li> </ul>	<ul style="list-style-type: none"> <li>- Check refrigerator compartment is overcooled (when button pressed on weak).</li> <li>- Check parts are faulty.</li> </ul>	<ul style="list-style-type: none"> <li>- Replace faulty parts.</li> </ul>
	<p>4) Bad defrosting</p> <ul style="list-style-type: none"> <li>- Heater wire is cut.</li> <li>- Defective defrost sensor.</li> <li>- Defrosting cycle.</li> </ul>	<ul style="list-style-type: none"> <li>- Check frost on the evaporator after disassembling shroud and fan grille.</li> <li>- Check ice on intake port of freezer and refrigerator compartment.</li> </ul>	<ul style="list-style-type: none"> <li>- Check parts related to defrosting</li> <li>- Check defrosting. (Check ice on evaporator and pipe.)</li> </ul>
	<p>5) Customers are not familiar with this machine.</p> <ul style="list-style-type: none"> <li>- Door opens.</li> <li>- High temperature, high moisture, and high load.</li> </ul>	<ul style="list-style-type: none"> <li>- Check food interferes with door closing.</li> <li>- Check ice on the ceilings.</li> </ul>	<ul style="list-style-type: none"> <li>- Be acquainted with how to use.</li> </ul>



Problem	Cause	Check	Measure
Ice in the freezer compartment. - Surface of fan grille. - Wall of freezer compartment. - Cool air discharging port. - Basket(rack) area. - Food surface. - Icing in the shute.	1) Bad cooling air circulation. - Intake port is clogged in the freezer compartment. - Discharging port is Clogged. - Too much food is stored. - Bad defrosting.	- Check food storage conditions visually.(Check clogging at intake and discharging port of cooling air.) - Check food occupation ratio in volume (Less than 75%). - Check frost on the evaporator after dissembling shroud and fan grille. - Check icing at intake port of refrigerator compartment.	- Be acquainted with how to use. - Check defrost (Check ice on the evaporator and pipes after forced defrosting).
	2) Bad freezer compartment door - Faulty gasket - Faulty assembly	- Check gasket attachment conditions. - Check door assembly conditions.	- Correct the gasket attachment conditions and replace it. - Door assembly and replacement
	3) Over freezing in the freezer compartment. - Faulty MICOM.	- Refrigerator operates pull down. (Check if it is operated intermittently) - The Temperature of freezer compartment is satisfactory, but over freezing happens in the refrigerator compartment even though the notch is set at <b>weak</b> .	-Replace defective parts.
	4) Bad defrosting. - Heater wire is cut. - Faulty defrost sensor. - Defrosting cycle	- Check frost on the evaporator after dissembling shroud and grille. - Check ice on the intake port in the refrigerator compartment.	- Check parts related to defrosting - Check defrosting. Check ice on the evaporator and pipes after forced defrosting.
	5) User is not familiar with how to use. - Door opens. - High moisture food water is stored.	- Check food holds door open. - Check ice on the ice tray.	- Be acquainted with how to use.

## 2-7. Sound

Problems	Causes	Checks	Measures
Hiss sound	1. Loud sound of compressor operation.	1.1 Check the level of the refrigerator. 1.2 Check the bushing seat conditions (sagging and aging).	1) Maintain horizontal level. 2) Replace bushing and seat if they are sagged and aged. 3) Touch the piping at various places along its route. Install a damper at the point where your touch reduces the noise. 4) Avoid pipe interference. 5) Replace defective fan and fan motor. 6) Adjust fan to be in the center of the fan guide. 7) Leave a clearance between interfering parts and seal gaps between the structures. 8) Reassemble the parts which make sound. 9) Leave a clearance if evaporator pipes and suction pipe touch freezer shroud.
	2. Pipes resonate sound which is connected to the compressor.	2.1 Check the level of pipes connected to the compressor and their interference. 2.2 Check bushing inserting conditions in pipes. 2.3 Touch pipes with hands or screw-driver (check the change of sound).	
	3. Fan operation sound in the freezer compartment.	3.1 Check fan insertion depth and blade damage. 3.2 Check the interference with structures. 3.3 Check fan motor. 3.4 Check fan motor bushing insertion and aging conditions.	
	4. Fan operation sound in the compressor compartment.	4.1 Same as fan confirmation in the refrigerator. 4.2 Check drip tray leg insertion. 4.3 Check the screw fastening conditions at condenser and drip tray.	

Problems	Causes	Checks	Measures
Vibration sound. Clack.	1. Vibration of shelves and foods in the refrigerator. 2. Pipes interference and capillary tube touching in the compressor compartment. 3. Compressor stopper vibration. 4. Moving wheel vibration. 5. Other structure and parts vibration.	1-1. Remove and replace the shelves in the refrigerator 1-2. Check light food and container on the shelves. 2-1. Touch pipes in the compressor compartment with hands. 2-2. Check capillary tube touches cover back. 3-1. Check compressor stopper Vibration. 4-1. Check vibration of front and rear moving wheels. 5-1. Touch other structures and parts.	1) Reassemble the vibrating parts and insert foam or cushion when vibration is severe. 2) Leave a clearance where parts interfere with each other. 3) Reduce vibration with bushing and restrainer if it is severe. (especially compressor and pipe) 4) Replace compressor stopper if vibrates severely.
Irregular sound. Click .	1. It is caused by heat expansion and contraction of evaporator, shelves, and pipes in the refrigerator.	1-1 Check time and place of sound sources.	1) Explain the principles of refrigeration and that the temperature difference between operation and defrosting can make sounds. 2) If evaporator pipe contacts with other structures, leave a clearance between them (freezer shroud or inner case).

<b>Problems</b>	<b>Causes</b>	<b>Checks</b>	<b>Measures</b>
Sound Popping (almost the same as animals crying sound).	It happens when refrigerant expands at the end of capillary tube.	<ul style="list-style-type: none"> <li>- Check the sound of refrigerant at the initial installation.</li> <li>- Check the sound when the refrigerator starts operation after forced defrosting.</li> <li>- Check the restrainer attachment conditions on the evaporator and capillary tube weld joints.</li> </ul>	<ul style="list-style-type: none"> <li>- Check the restrainer attached on the evaporator and capillary tube weld joints and attach another restrainer.</li> <li>- If it is continuous and severe, insert capillary tube again (depth 15±3mm)</li> <li>- Fasten the capillary tube to suction pipes or detach in the compressor compartment.</li> <li>- Explain the principles of freezing cycles.</li> </ul>
Water boiling or flowing sound.	It happens when refrigerant passes orifice in accumulator internal pipes by the pressure difference between condenser and evaporator.	<ul style="list-style-type: none"> <li>- Check the sound when compressor is turned on.</li> <li>- Check the sound when compressor is turned off.</li> </ul>	<ul style="list-style-type: none"> <li>- Explain the principles of freezing cycle and refrigerant flowing phenomenon and internal pressure difference.</li> <li>- If sound is severe, wrap the accumulator with foam and restrainer</li> </ul>
Sound of whistle when door closes.	When door closes, the internal pressure of the refrigerator decreases sharply below atmosphere and sucks air into the refrigerator, making the whistle sound.	<ul style="list-style-type: none"> <li>- Check the sound by opening and closing the refrigerator or freezer doors.</li> </ul>	<ul style="list-style-type: none"> <li>- Broaden the cap of discharge hose for defrosting in the compressor compartment.</li> <li>- Seal the gap with sealant between outer and inner cases of hinge in door.</li> </ul>

## 2-8. Odor

Problems	Causes	Checks	Measures
Food Odor.	Food (garlic, kimchi, etc)	<ul style="list-style-type: none"> <li>- Check the food is not wrapped.</li> <li>- Check the shelves or inner wall are stained with food juice.</li> <li>- Be sure food is securely covered with plastic wrap.</li> <li>- Check food cleanliness.</li> </ul>	<ul style="list-style-type: none"> <li>- Dry the deodorizer in a sunny place with adequate ventilation.</li> <li>- Store the food in the closed container instead of vinyl wraps.</li> <li>- Clean the refrigerator and set button at <b>strong</b>.</li> </ul>
Plastic Odor.	Odors of mixed food and plastic odors.	<ul style="list-style-type: none"> <li>- Check wet food is wrapped with plastic bowl and bag.</li> <li>- It happens in the new refrigerator.</li> </ul>	<ul style="list-style-type: none"> <li>- Clean the refrigerator.</li> <li>- Persuade customers not to use plastic bag or wraps with wet food or odorous foods.</li> </ul>
Odor from the deodorizer.	Odor from the old deodorizer.	<ul style="list-style-type: none"> <li>- Check the deodorizer odors.</li> </ul>	<ul style="list-style-type: none"> <li>- Dry the deodorizer with dryer and then in the shiny and windy place.</li> <li>- Remove and replace the deodorants.</li> </ul>

## 2-9. Micom

Problems	Symptom	Causes		Checks	Meas
Bad PCB electric power.	All display LCD are off.	Bad connection between Main PCB and display circuit.	Bad connector connection from main PCB to display PCB.	Visual check on connector connection.	Reconnect connector
		Defective PCB transformer.	PCB transformer winding is cut.	Check resistance of PCB transformer input and output terminals with a tester. (If resistance is infinity, transformer winding is cut).	Replace PCB transformer
			PCB transformer temperature fuse is burnt out.		
		Defective PCB electric circuit parts.	Defective regulator IC (7812, 7805).	Check voltage at input/output terminals.	Replace regulator
			PCB electric terminal fuse is burnt out.	Check fuse in PCB electric terminal with a tester.	Replace fuse
			STR Parts are damaged.	Check if STR No. 2 and 3 pins are cut when power is off.	Replace STR
Abnormal display LCD operation	Bad connection between Main PCB and display circuit.	Lead Wire connecting main PCB and display PCB is cut or connector terminal connection is bad.	Check Lead Wire terminals connecting Main PCB and display PCB with a tester.	Reconnect Wire and connect display contact terminal. Lead Wire	
	Defective LCD.	Defective LCD.	Check if all LCD are on when Main PCB Test switch is pressed (or when both freezer key and power freezer key are pressed at the same time for more than one second.)	Replace LCD PCB.	

Problems	Symptom	Causes		Checks	Measur
Bad cooling.	Freezer temperature is high.	Compressor does not start.	Compressor Lead Wire is cut.	Check compressor Lead Wire with a tester.	Reconnect Wire.
			Defective compressor driving relay.	Measure voltage at PCB CON2 (3&9) after pressing main PCB test switch once. It is OK if voltage is normal.	Replace relay and RY2.
		Defective freezer sensor.	Defective Freezer sensor parts.	Check resistance of freezer sensor with a tester.	Replace freezer sensor.
			The wrong sensor has been installed. Order by model number and part number.	Confirm the color of sensor in circuits (main PCB sensor housing).	Repair main sensor housing.
		Defective freezer fan motor.	Fan motor lead wire is cut.	Check fan motor lead wire with a tester.	Reconnect wire.
				<ul style="list-style-type: none"> <li>• Defective door switch (freezer, refrigerator, home bar).</li> <li>• Defective fan motor.</li> <li>• Defective fan motor driving relay.</li> </ul>	Measure the voltage between PCB power blue line and fan motor after pressing test switch of Main PCB. If the voltage is normal, it is OK.
Faulty defrost.		Refer to faulty defrost items in trouble diagnosis functions.			

Problem	Sympto	Cause		Check	Meas
Bad cooling	Wrong Refrigerator temperature.	Defective Step Motor Damper.	Check Step Motor damper motor and reed switch and lead wire are cut. Check Step Motor damper part.	Check if Step Motor damper motor and reed switch lead wire are cut with a tester.	Reconnect wire.
				Refer to Step Motor damper in parts repair guide.	Replace Step Motor damper or control board.
			Check Step Motor damper Motor driving relay in PCB.	Refer to Step Motor damper in parts repair guide.	Replace motor PCB.
			Foreign materials in Step Motor damper baffles.	Check Step Motor damper baffle visually.	Remove foreign materials.
			Ice formation on Step Motor damper baffles.	Check if Step Motor damper Heater wire is cut with a tester.	Replace Step Motor damper or control Board.
		Defective refrigerator sensor	Defective refrigerator sensor parts.	Check the resistance of refrigerator sensor with a tester.	Replace refrigerator sensor.
			Refrigerator sensor is substituted for other sensor.	Check the sensor color in the circuit. (main PCB sensor housing.)	Repair main sensor housing.
			Defective refrigerator sensor assembly condition.	Check if refrigerator sensor is not fixed at cover sensor but inner case visually.	Fix again refrigerator sensor.









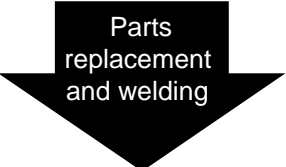

Problems	Symptom	Causes	Checks	Measur
Bad defrost.	Defrost is not working.	Defrost lead wire is cut.	Check if defrost lead wire is cut with a tester.	Reconnect Wire.
		Defective defrost driving relay.	Check the voltage of CON2 (1 and 7) with a tester after pressing main PCB test switch twice. If the voltage is normal then it is OK.	Replace relay and RY 3
		Defective defrost sensor parts.	Check the resistance of defrost sensor with a tester.	Replace defrost sensor.
Defective buzzer	Buzzer continuously rings or door opening alarm does not work.	Defective connecting lead wire from main PCB to door switch.	Check lead wire related to door switch with a tester.	Repair lead wire.
		Defective door switch parts.	Refer to door switch in parts repair guide.	Replace door switch.
Defective display button	Buzzer does not sound and buttons do not operate.	Key input wire is cut or bad connector terminal contact in main PCB and display PCB connecting lead wire.	Check input wire with a tester.	Reconnect wire and test directly contact terminal lead wire.
		Key is continuously depressed due to structural interference.	Disassemble frame display and confirm visually.	Adjust or remove interfering structures.

<b>Problems</b>	<b>Symptom</b>	<b>Causes</b>	<b>Checks</b>	<b>Meas</b>
Defective display button.	Buzzer does not sound and buttons do not operate.	Trouble mode indication.	Check trouble diagnosis function.	Repair tro
Door Buzzer	Buzzer continuously rings or door opening alarm does not work.	Defective connecting lead wire from main PCB to door switch.	Check lead wire associated with door switch.	Repair lea
		Defective freezer compartment door switch parts.	Refer to door switch in parts repair guide.	Replace f compartment switch.
Bad water/ice dispenser.	Ice and water are not dispensed.	Defective connecting lead wire from Main PCB to lever switch.	Check Lead Wire associated with lever switch with a tester.	Repair lea
		Defective lever switch parts	Refer to door switch in parts repair guide.	Replace l
		Defective photo coupler IC parts.	Check voltage change at photo coupler output terminals with lever switch pressed. It is OK if voltage change is between 0V - 5V.	Replace p coupler IC
		Defective relay associated with ice dispense (geared motor, cube, and dispenser solenoid).	Check relay (RY4, RY5, RY12) with a tester.	Replace o relay.
		Defective parts associated with ice dispense (geared motor, cube, and dispenser solenoid).	Check resistance of parts with a tester.	Replace o parts.
		Defective relay associated with water dispense.	Check relay (RY7) with a tester	Replace o relay.
		Defective parts associated with water dispenser.	Check resistance of parts with a tester.	Replace o parts.

### 3. Sealed System Heavy Repair

#### Summary Of Heavy Repair

Process	Contents	Tools
		
	<ul style="list-style-type: none"> <li>- Cut charging pipe ends and discharge refrigerant from drier and compressor.</li> </ul>	Filter, side cutters
	<ul style="list-style-type: none"> <li>- Use R134a oil and refrigerant for compressor and drier</li> <li>- Confirm N<sub>2</sub> sealing and packing conditions before use. Use good one for welding and assembly.</li> <li>- Weld under nitrogen gas atmosphere. (N<sub>2</sub> gas pressure: 0.1-0.2kg/cm<sup>2</sup>).</li> <li>- Repair in a clean and dry place.</li> </ul>	Pipe Cutter, Gas welder, N <sub>2</sub> gas
	<ul style="list-style-type: none"> <li>- Evacuate for more than forty minutes after connecting manifold gauge hose and vacuum pump to high (drier) and low (compressor refrigerant discharging parts) pressure sides.</li> <li>- Evacuation Speed: 113 liters/minute.</li> </ul>	Vacuum pump R134a exclusively, Manifold gauge.
	<ul style="list-style-type: none"> <li>- Weigh and control the allowance of R134a charging canister in a vacuum conditions to be <math>\pm 5</math> g with electronic scales and charge through compressor inlet (Charge while compressor operates).</li> <li>- Weld carefully after pinching off the inlet pipe.</li> </ul>	R134a exclusive charging canister (mass cylinder), refrigerant R134a manifold gauge, electronic scales, pinch-off plier, gas welding machine
	<ul style="list-style-type: none"> <li>- Check leak at weld joints.                             <ul style="list-style-type: none"> <li>□ Minute leak : Use electronic leak detector</li> <li>□ Big leak : Check visually.</li> </ul> </li> <li>Note: Do not use soapy water for check.</li> <li>- Check cooling capacity                             <ol style="list-style-type: none"> <li>1. Check radiator manually to see if warm.</li> <li>2. Check hot line pipe manually to see if warm.</li> <li>3. Check frost formation on the whole surface of the evaporator.</li> </ol> </li> </ul>	Electronic Leak Detector, Driver (Ruler).
	<ul style="list-style-type: none"> <li>- Remove flux from the silver weld joints with soft brush or wet rag. Flux may be the cause of corrosion and leaks.</li> <li>- Clean R134a exclusive tools and store them in a clean tool box or in their place.</li> </ul>	Copper brush, Rag, Tool box
	<ul style="list-style-type: none"> <li>- Installation should be conducted in accordance with the standard installation procedure. Leave space of more than 5 cm (2 inches) from the wall for compressor compartment cooling fan mounted model.</li> </ul>	

### 3-3. Precautions During Heavy Repair

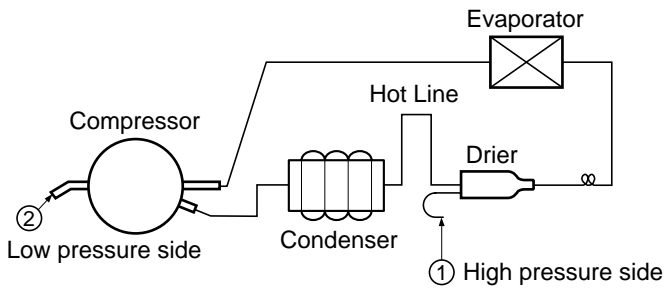
Items	Precautions
1. Use of tools.	1) Use special parts and tools for R134a.
2. Recovery of refrigerant.	<p>1) Continue to recover the refrigerant for more than 5 minutes after turning the refrigerator off.</p> <p>2) Install a piercing type valve on the high pressure line (drier side). Then use the appropriate recovery equipment to recover the refrigerant from the system. When the refrigerant has been recovered, install a piercing type valve on the low pressure side. <b>IT IS IMPORTANT TO OPEN THE SYSTEM IN THIS ORDER TO KEEP THE OIL FROM BEING FORCED OUT.</b></p> <p>The use of piercing type valves will allow future servicing and eliminates the possibility of a defective pinch off.</p>  <p>The diagram illustrates a refrigeration cycle. On the left is a circular compressor. A line from the compressor goes to a condenser, represented by a coil of four cylinders. From the condenser, a line goes up and then right, labeled 'Hot Line'. This line passes through a drier, which is a rectangular component with a small circle inside. After the drier, the line goes up and then right to an evaporator, represented by a square with an 'X' inside. The line then goes down and back to the compressor. A circled '2' is placed at the low pressure side (between the compressor and condenser), and a circled '1' is placed at the high pressure side (between the condenser and drier).</p>
3. Replacement of drier.	1) Be sure to replace drier with R134a only when repairing pipes and injecting refrigerant.
4. Nitrogen blowing welding.	1) Use pressurized nitrogen to prevent oxidation inside the piping. (Nitrogen pressure : 0.1~0.2 kg/cm <sup>2</sup> .)
5. Others.	<p>1) Only nitrogen or R134a should be used when cleaning the inside of piping of the sealed system.</p> <p>2) Check leakage with an electronic leakage tester.</p> <p>3) Be sure to use a pipe cutter when cutting pipes.</p> <p>4) Be careful not the water let intrude into the inside of the cycle.</p>

**3-4. Practical Work For Heavy Repair**

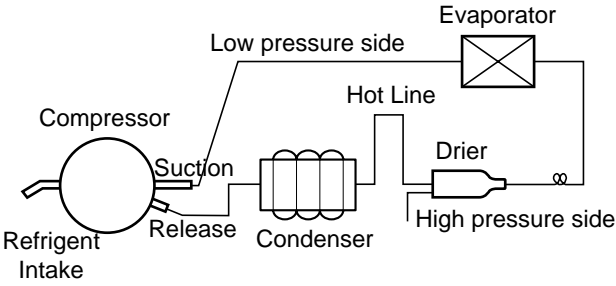
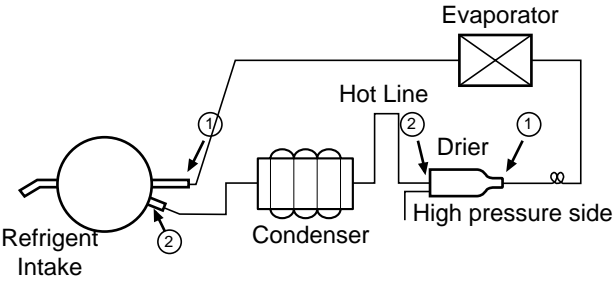
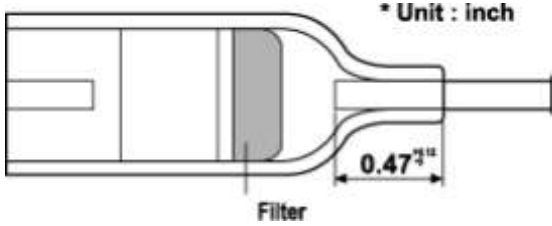
Items	Precautions
<p>1. Removal of residual refrigerant.</p>	<div style="display: flex; justify-content: space-between; align-items: flex-start;"> <div style="text-align: center;">  </div> <div style="width: 25%;"> <p><b>KEY POINT</b> Observe the sequence for removal of refrigerant. (If not, compressor oil may leak.)</p> </div> </div> <p>1) Continue to recover the refrigerant for more than 5 minutes after turning the refrigerator off.</p> <p>2) Install a piercing type valve on the high pressure line (drier side). Then use the appropriate recovery equipment to recover the refrigerant from the system. When the refrigerant has been recovered, install a piercing type valve on the low pressure side. <b>IT IS IMPORTANT TO OPEN THE SYSTEM IN THIS ORDER TO KEEP THE OIL FROM BEING FORCED OUT.</b></p> <p>The use of piercing type valves will allow future servicing and eliminates the possibility of a defective pinch off.</p>
<p>2. Nitrogen blowing welding.</p>	<div style="display: flex; justify-content: space-between; align-items: flex-start;"> <div style="text-align: center;">  </div> <div style="width: 25%;"> <p><b>KEY POINT</b> Welding without nitrogen blowing produces oxidized scales inside a pipe, which affect performance and reliability of a product.</p> </div> </div> <p><b>When replacing a drier:</b> Weld ① And ② parts by blowing nitrogen (0.1~0.2kg/cm<sup>2</sup>) to high pressure side after assembling a drier.</p> <p><b>When replacing a compressor:</b> Weld ① And ② parts by blowing nitrogen to the low pressure side.</p> <p>Note) For other parts, nitrogen blowing is not necessary because it does not produce oxidized scales inside pipe because of its short welding time.</p>
<p>3. Replacement of drier.</p>	<div style="display: flex; justify-content: space-between; align-items: flex-start;"> <div style="text-align: center;">  </div> <div style="width: 25%;"> <p><b>KEY POINT</b> Be sure to check the inserted length of capillary tube when it is inserted. (If inserted too far, the capillary tube will be blocked by the filter.)</p> </div> </div> <p><b>Inserting a capillary tube</b> Measure distance with a ruler and put a mark(12<sup>+3/-0</sup>)on the capillary tube. Insert tube to the mark and weld it</p>

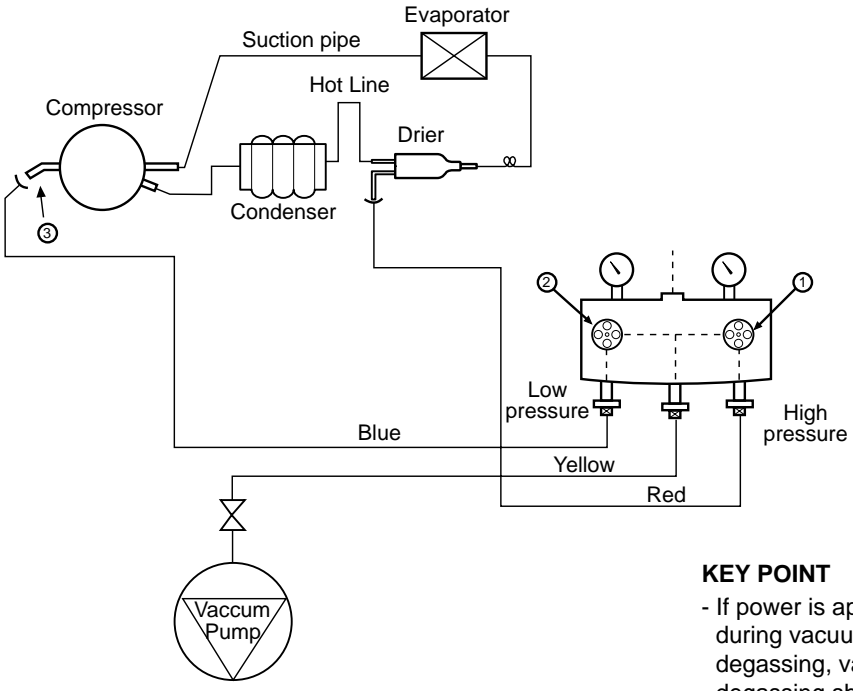
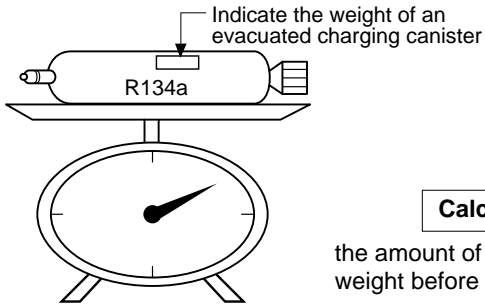
Items	Precautions
4. Vacuum degassing.	<div style="text-align: center;">  </div> <p><b>KEY POINT</b></p> <ul style="list-style-type: none"> <li>- If power is applied during vacuum degassing, vacuum degassing shall be more effective.</li> <li>- Run the compressor while charging the system. It is easier and works better.</li> </ul> <p><b>Pipe Connection</b> Connect the red hose to the high pressure side and the blue hose to the low pressure side.</p> <p><b>Vacuum Sequence</b> Open valves ① and ② and evacuate for 40 minutes. Close valve ①.</p>
5. Refrigerant charging.	<p><b>Charging sequence</b></p> <ol style="list-style-type: none"> <li>1) Check the amount of refrigerant supplied to each model after completing vacuum degassing.</li> <li>2) Evacuate charging canister with a vacuum pump.</li> <li>3) Measure the amount of refrigerant charged. <ul style="list-style-type: none"> <li>- Measure the weight of an evacuated charging canister with an electronic scale.</li> <li>- Charge refrigerant into a charging canister and measure the weight. Calculate the weight of refrigerant charged into the charging canister by subtracting the weight of an evacuated charging canister.</li> </ul> </li> </ol> <div style="text-align: center;">  </div> <p><b>KEY POINT</b></p> <ul style="list-style-type: none"> <li>- Be sure to charge the refrigerant at around 25°C [77°F].</li> <li>- Be sure to keep -5g in the winter and +5g in summer.</li> </ul> <div style="border: 1px solid black; padding: 5px; text-align: center; margin: 10px auto; width: fit-content;"> <b>Calculation of amount of refrigerant charged</b> </div> <p>the amount of refrigerant charged= weight after charging - weight before charging (weight of an evacuated cylinder)</p>

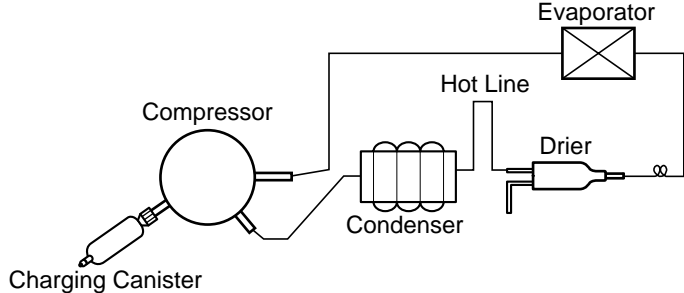
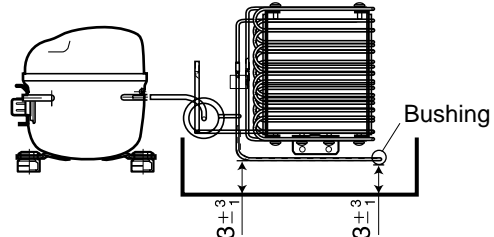
Items	Precautions
	 <p>4) Refrigerant Charging Charge refrigerant while operating a compressor as shown above.</p> <p>5) Pinch the charging pipe with a pinch-off plier after completion of charging.</p> <p>6) Braze the end of a pinched charging pipe with copper brazer and take a gas leakage test on the welded parts.</p>
6. Gas-leakage test	* Test for leaks on the welded or suspicious area with an electronic leakage tester.
7. Pipe arrangement in each cycle	<p>When replacing components, be sure each pipe is replaced in its original position before closing the cover of the mechanical area.</p> 

### 3-5. Standard Regulations For Heavy Repair

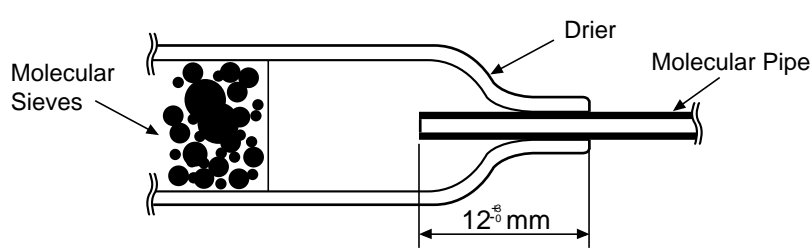
<ol style="list-style-type: none"> <li>1) Observe the safety precautions for gas handling.</li> <li>2) Use JIG (or a wet towel) in order to prevent electric wires from burning during welding. (In order to prevent insulation break and accident.)</li> <li>3) The inner case will melt and the insulation will burn.</li> <li>4) The copper piping will oxidize.</li> <li>5) Do not allow aluminum and copper pipes to touch. (In order to prevent corrosion.)</li> <li>6) Observe that the inserted length of a capillary tube into a drier should be <math>12^{+3}_{-0}</math> mm.</li> </ol>  <ol style="list-style-type: none"> <li>7) Make sure that the inner diameter is not distorted while cutting a capillary tube.</li> <li>8) Be sure that the suction pipe and the filling tube should not be substituted each other during welding. (High efficiency pump.)</li> </ol>
---

3-6. Brazing Reference Drawings

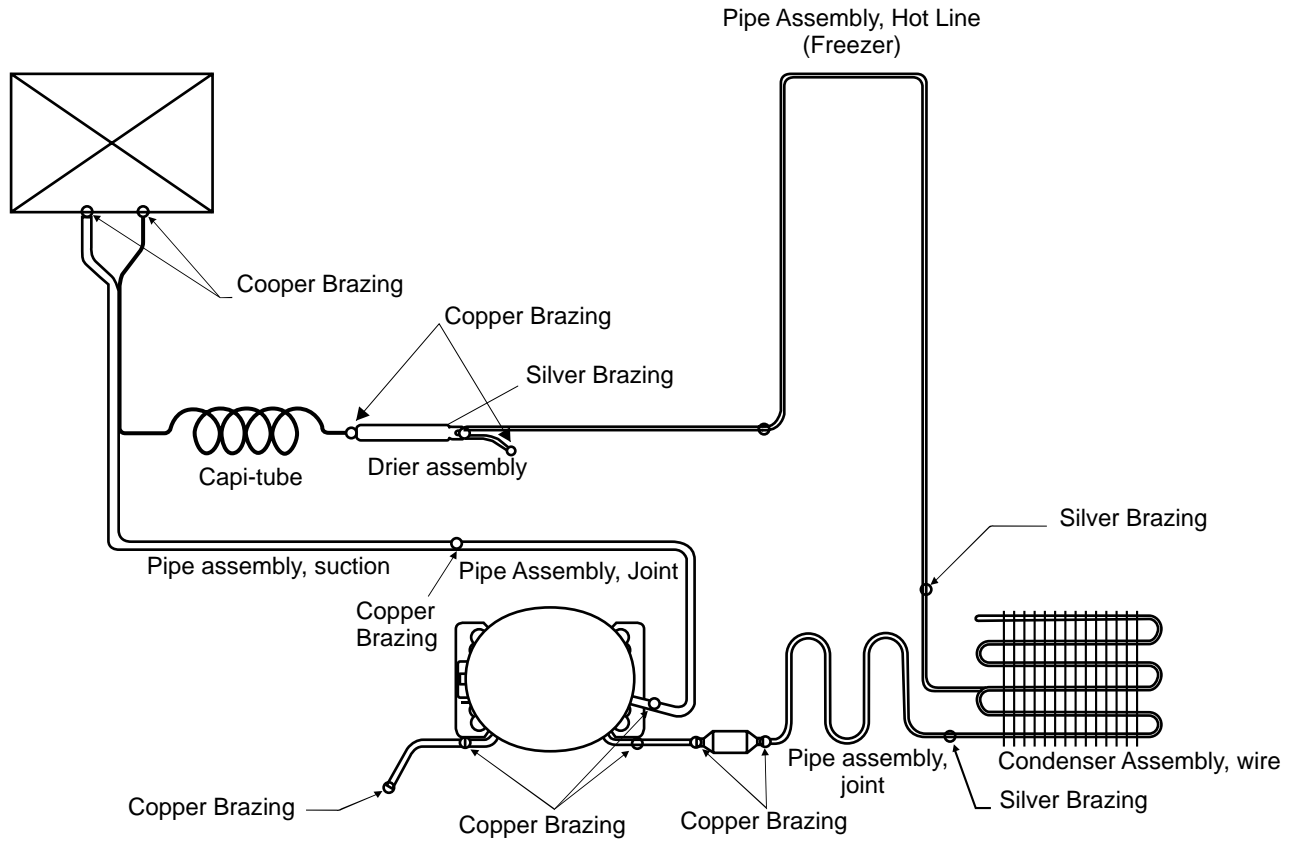



## 4. HOW TO DEAL WITH CLAIMS

### 4-1. Sound

Problems	Checks and Measures
Hiss sounds	<p><b>Explain general principles of sounds.</b></p> <ul style="list-style-type: none"> <li>• All refrigerators make noises when they run. The compressor and fan produce sounds. There is a fan in the freezer compartment which blows cool air to freezer and refrigerator compartments. <b>Hiss</b> sounds are heard when the air passes through the narrow holes into the freezer and refrigerator compartments.</li> </ul> <p><b>Cooling Fan sound in the compressor compartment.</b></p> <ul style="list-style-type: none"> <li>• There is a fan on the back of the refrigerator which cools the compressor compartment. If there is a small space between the refrigerator and the wall, the air circulation sounds may be noticeable.</li> </ul> <p><b>Noise of Compressor.</b></p> <ul style="list-style-type: none"> <li>• This operating sound happens when the compressor compresses the refrigerant. The compressor rotates at 3600 RPM. The sound of compressor. Bigger refrigerators make more noise than small ones</li> </ul>
Click sounds	<p><b>Explain the principles of temperature change.</b></p> <ul style="list-style-type: none"> <li>• The sounds happens when pipes and internal evaporator in the refrigerator compartment expand and contract as the temperature changes during the refrigerator operation. This sound also happens during defrosting, twice a day, when the ice on the evaporator melts.</li> </ul>
Clunk sound	<p><b>Explain that it comes from the compressor when the refrigerator starts.</b></p> <ul style="list-style-type: none"> <li>• When the refrigerator operates, the piston and motor in the compressor rotate at 3600 RPM. This sound is caused by the vibration of motor and piston when they start and finish their operation. This phenomenon can be compared with that of cars. When an automobile engine starts, it is loud at first but quiets down quickly. When the engine stops, so does the vibration.</li> </ul>
Vibration sound	<p><b>Check the sound whether it comes from the pipes vibration and friction.</b></p> <ul style="list-style-type: none"> <li>• Insert bushing or leave a space between pipes to avoid the noise.</li> <li>• Fix the fan blade if it is hitting on the shroud</li> <li>• Fix the drip tray if it is loosened.</li> </ul> <p><b>Sound depends on the installation location.</b></p> <ul style="list-style-type: none"> <li>• Sound becomes louder if the refrigerator is installed on a wooden floor or near a wooden wall. Move it to the another location.</li> <li>• If the refrigerator is not leveled properly, a small vibration can make a loud sound. Please adjust the level of the refrigerator.</li> </ul>

Problems	Checks and Measures
Sounds of water flowing	<p>Explain the flow of refrigerant.</p> <ul style="list-style-type: none"> <li>• When the refrigerator stops, the water flowing sound happens. This sound happens when the liquid or vapor refrigerant flows from the evaporator to compressor.</li> </ul>
Click sounds	<p>Explain the characteristics of moving parts.</p> <ul style="list-style-type: none"> <li>• This noise comes from the MICOM controller's switch on the top of the refrigerator when it is turned on and off.</li> </ul>
<p>Noise of Icemaker operation (applicable to model with Icemaker).</p> <ul style="list-style-type: none"> <li>- Noise produced by ice dropping and hitting ice bin.</li> <li>- Noise from motor sounds Hiss .</li> </ul>	<p>Explain the procedure and principles of Icemaker operation.</p> <ul style="list-style-type: none"> <li>• Automatic Icemaker repeats the cycle of water supplying → Icemaking → ice ejection. When water is supplied, the water supply valve in the machine room makes sounds like Hiss and water flowing also makes sound. When water freezes, clicking sounds are heard. When ice is being ejected, sounds like Hiss produced by a motor to rotate an ice tray and ice dropping and hitting ice bin sounds are also heard.</li> </ul>
Noise when supplying water.	<p>Explain the principles of water supplied to dispenser.</p> <ul style="list-style-type: none"> <li>• When the water supply button in the dispenser is pressed, the water supply valve in the compressor compartment opens and let the water flow to the water tank in the lower part of the refrigerator compartment. The water is dispensed by this pressure. When this happens, motor sound and water flowing sound are heard.</li> </ul>
Noise when supplying ice.	<p>Explain the principles of ice supply and procedure of crushed icemaking in a dispenser.</p> <ul style="list-style-type: none"> <li>• When ice cube button is pressed, ice stored in the ice bin is moved by an auger and dispensed. If crushed ice button is pressed, the ice cube is crushed. When this happens, ice crushing and hitting ice bin sounds are heard.</li> </ul>

#### 4-2. Measures for Symptoms on Temperature

Problems	Checks and Measures
Refrigeration is weak.	<p><b>Check temperature set in the temperature control knob.</b></p> <ul style="list-style-type: none"> <li>• Refrigerator is generally delivered with the button set at <b>normal use</b> (MID). But customer can adjust the temperature set depending on their habit and taste. If you feel the refrigeration is weak, then set the temperature control button at <b>strong</b> position. If you adjust the button in the freezer compartment as well, the refrigeration is stronger than adjusting refrigerator only.</li> </ul>
The food in the chilled drawer is . not frozen but defrosted	<p><b>The chilled drawer does not freeze food.</b></p> <ul style="list-style-type: none"> <li>• Use chilled drawer for storing fresh meat or fish for short periods. For storing for a long periods or freezing food, use a freezer compartment. It is normal that frozen foods thaw above the freezing temperature (in the chilled drawer).</li> </ul>
Refrigerator water is not cool.	<p><b>Check the water storage location.</b></p> <ul style="list-style-type: none"> <li>• If water is kept in the door rack, move it to a refrigerator shelf. It will then become cooler.</li> </ul>
Ice cream softens.	<p><b>Explain the characteristics of ice cream.</b></p> <ul style="list-style-type: none"> <li>• The freezing point of ice cream is below -15°C[5°F]. Therefore ice cream may melt if it is stored in the door rack.</li> <li>• Store ice cream in a cold place or set the temperature control button of a freezer at <b>strong</b> position.</li> </ul>
Refrigeration is too strong.	<p><b>Check the position of temperature control button.</b></p> <ul style="list-style-type: none"> <li>• Check if refrigeration is strong in whole area of the refrigerator or partly near the outlet of the cooling air. If it is strong in whole area, set the control button at <b>weak</b>. If it is strong only near the outlet of cool air, keep food (especially damp foods and easily frozen foods) away from the outlet.</li> </ul>
Vegetables are frozen.	<p><b>Check the vegetables storage.</b></p> <ul style="list-style-type: none"> <li>• If vegetables are stored in the refrigerator shelf or chilled drawer instead of vegetable drawer, they will be frozen. Set the control button at <b>weak</b> if they are also frozen in the vegetable drawer.</li> </ul>
The food stored at inside of the shelf freezes even the control button is set at <b>MID</b> .	<p><b>Check if food is stored near the outlet of the cooling air.</b></p> <ul style="list-style-type: none"> <li>• The temperature at cooling air outlet is always below the freezing point. Do not store food near the outlet of the cooling air as it block the air circulation. Do not block the outlet. If the outlet of the cooling air is blocked, the refrigerator compartment will not be cooled.</li> </ul>

### 4-3. Odor and Frost

Problems	Checks and Measures
Odor in the refrigerator compartment.	<p>Explain the basic principles of food odor.</p> <ul style="list-style-type: none"> <li>• Each food has its own particular odor. Therefore it is impossible to prevent or avoid food odor completely when food is stored in the completely sealed refrigerator compartment. The deodorizer can absorb some portions of the odor but not completely. The intensity of odor depends on refrigerator conditions and environments.</li> </ul> <p>Check the temperature control button and set at strong.</p> <ul style="list-style-type: none"> <li>• Clean inside of the refrigerator with detergent and remove moisture. Dry inside the refrigerator by opening the door for about 3 or 4 hours and then set the temperature control button at strong .</li> </ul>
Frost in the freezer compartment	<p>Explain the basic principles of frost formation.</p> <ul style="list-style-type: none"> <li>• The main causes for frosting:               <ul style="list-style-type: none"> <li>- Door was left open.</li> <li>- Air penetration through the gasket</li> <li>- Too frequent door opening. (parties. etc.)</li> <li>- Hot foods are stored before they are cooled down. The temperature of freezer is -19°C[-2.2°F]. if temperature is set at MID. If hot air comes into the refrigerator, fine frost forms as cold air mixes with hot air. If this happens quite often, much frost forms inside of the refrigerator. If the door is left open in Summer, ice may form inside of the refrigerator.</li> </ul> </li> </ul>
Frost in ice tray.	<p>Explain basic principles of frost formation.</p> <ul style="list-style-type: none"> <li>• When ice tray with full of water is put into a freezer compartment, the water evaporates. If cool air fan operates, the moisture attached to the jaw (protruded part) of ice mold will freeze and form frost. If warm water was put into the ice mold, the situation will become worse.</li> </ul>

#### 4-4. Others

Problems	Checks and Measures
The refrigerator case is hot.	<p>Explain the principles of radiator.</p> <ul style="list-style-type: none"> <li>The radiator pipes are installed in the refrigerator case and partition plate between the refrigerator and the freezer compartment in order to prevent condensation formation. Particularly in summer or after installation of refrigerator, it may feel hot but it is normal. If there is not enough space to dissipate heat, it can be hotter due to lack of heat radiation. Please install a refrigerator in a well-ventilated place and leave the clearance between refrigerator and wall:</li> </ul>
Small holes in a door liner	<p>Explain that the hole is for releasing gas.</p> <ul style="list-style-type: none"> <li>A small hole in the door liner is for releasing gas during insulation materials lining work. With a releasing hole, forming can be easily done .</li> </ul>
Electric bills are too much.	<p>Explain that the hole is to allow the air to escape when vacuum forming plastic parts and pumping foam insulation into cavities.</p> <p><b>NOTE!</b> Holes and releasing gas appear to be very crude and would not be acceptable in a manual.</p> <p>There are small holes in the plastic liner of some parts of the refrigerator. These holes allow plastic parts to be injection molded and vacuum formed by allowing air bubbles to be expelled. They also allow foam insulation to be pumped into cavities where air bubbles may build up.</p>
Condensation on the inside wall of the refrigerator compartment and the cover of properly vegetable drawer.	<p>Explain how to store foods</p> <ul style="list-style-type: none"> <li>Condensation forms when refrigerator is installed at damp area, door is frequently opened, and wet foods are not stored in the air tight container or wrapped. Be sure to store wet foods in airtight containers or securely covered in plastic wrap.</li> </ul>
When is the power connected?	<p>When should the power be connected ?</p> <ul style="list-style-type: none"> <li>You can connect the power immediately after installation. However, if the refrigerator was laid flat before or during installation, you must stand it upright for 6 hours before plugging it in. This allows the refrigerant oils to return to the sump in the compressor. If you operate the refrigerator before the oil has had a chance to settle, you could damage the compressor.</li> </ul>
Door does not open properly.	<p>Refrigerator compartment door does not open properly.</p> <ul style="list-style-type: none"> <li>When the door is open, warm open air comes into the compartment and is mixed up with cool air. This mixed air shall be compressed and increase the internal pressure when door is closed. This causes the door stucked closely to the refrigerator in a moment. (If the refrigerator is used for a long time, it will open smoothly.)</li> </ul> <p>When the refrigerator compartment door is opened and closed, the freezer compartment door moves up and down.</p> <ul style="list-style-type: none"> <li>When the refrigerator compartment door is opened and closed, fresh air comes into the freezer compartment and moves up and down the freezer compartment door.</li> </ul> <p>Door opens too easily.</p> <ul style="list-style-type: none"> <li>There is a magnet in the gasket so it closes securely without a gap. It can be held open easily if something is in the way and obstructs the door's closing</li> </ul> <p>A door does not close properly.</p> <ul style="list-style-type: none"> <li>If the refrigerator is not properly leveled, the doors will not close easily. Adjust the level using the leveling screws under the front of the refrigerator.</li> </ul>

# 9. HOW TO DISASSEMBLE AND ASSEMBLE

## 1. DOOR

### 1) Remove lower cover and then disconnect water supply tube in the lower part of freezer door.

- Pull the water supply tube (2) forward while pressing on the coupling (1) as shown in the drawing.

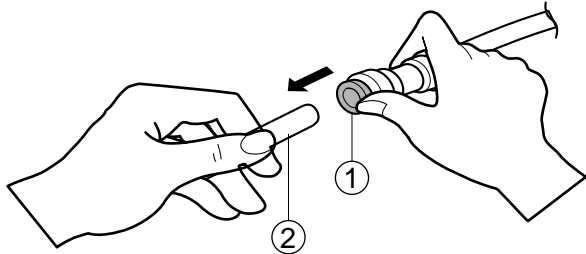

**!** Disconnecting the tube under the door causes about 1.5 liters water to flow out. Please put up a big container to prevent it.

### 2) Remove a freezer door.

- (1) Loosen hinge cover screw of freezer door and remove cover.  
Disconnect all connecting lines except grounding cord.

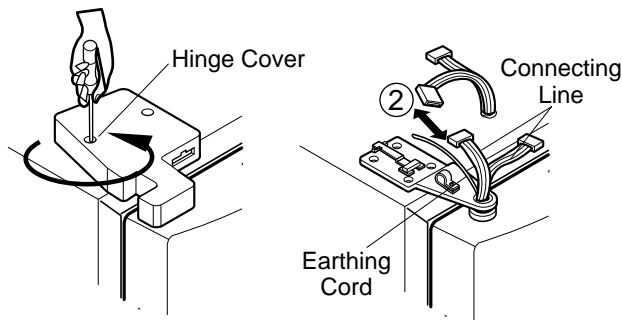

- (2) Turn hinge lever in arrow (A) direction until it is loosened and take it out in arrow (B) direction.

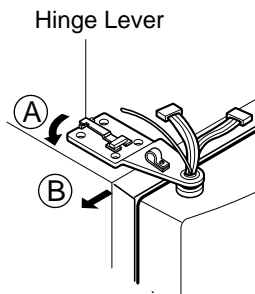

**Note :** • When disconnecting refrigerator door, turn hinge lever counterclockwise.

- If the hinge or bracket are bent during assembly, use two extra screws (Tap Tite M6, Left Hinge attaching screw) in the holes of the upper hinge.

- (3) Disconnect upper hinge (1) from the hinge supporter (2) by grasping the front part of upper hinge and lifting up (Hinge Assembly, U) in arrow direction (A) and pull forward in arrow (B) direction. Be careful because the door may fall, damaging the door, the floor, or injuring you.

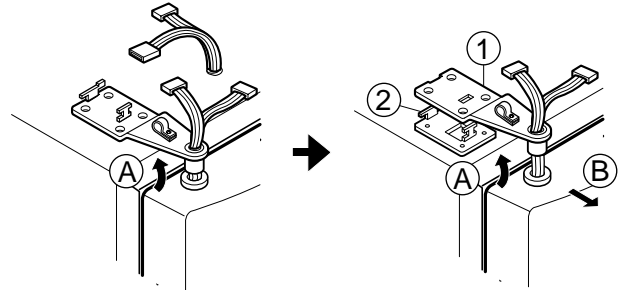

- (4) Lift up the freezer door (1) in arrow direction and disconnect the door from the lower hinge (2). Don't pull the door forward.

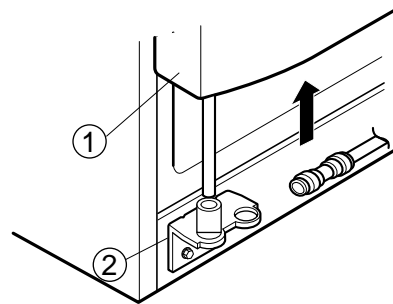

**Note :** • Lift up the freezer door until a water supply tube is fully taken out.

- (5) Assembly is the reverse order of disassembly

## 2. HANDLE

To move the refrigerator through a house door, could be necessary to get off door handle.

### 1. Removing the door handle

-Loosen the set screws with the 3/32" Allen wrench and remove the handle.

Note: If the handle mounting fasteners need to be tightened or removed, use a 1/4" Allen wrench.

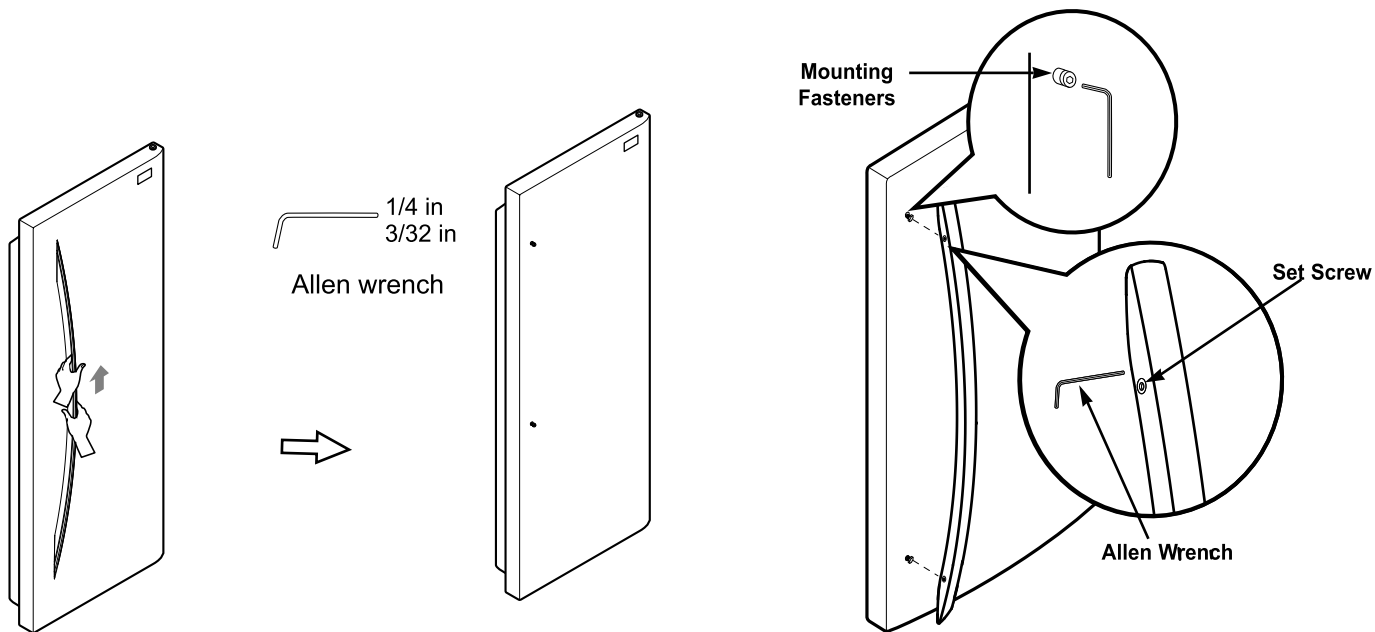

## 3. FAN SHROUD GRILLE

- 1) Loosen two screws after disconnecting a cap screw of a grille fan (U) with a screwdriver blade.
- 2) Disassembly of a grille fan (U): Pull forward after opening hook at part with a screwdriver blade.
- 3) Disconnect housing A of a grille fan (L) from the main body.
- 4) Disassembly of a grille fan (L): Hold upper part of a grille fan (L) and pull forward carefully.
- 5) Loosen two screws.
- 6) Disassembly of shroud. F(U): Disconnect housing of B after removing two rail guides with a screwdriver blade.
- 7) Disassembly of shroud. F(U): Hold upper part and pull forward.
- 8) Check foam sticking conditions around a shroud, F(U) and F(L) during assembling. If damaged, torn, or badly stuck, assemble with a new one after sealing well.

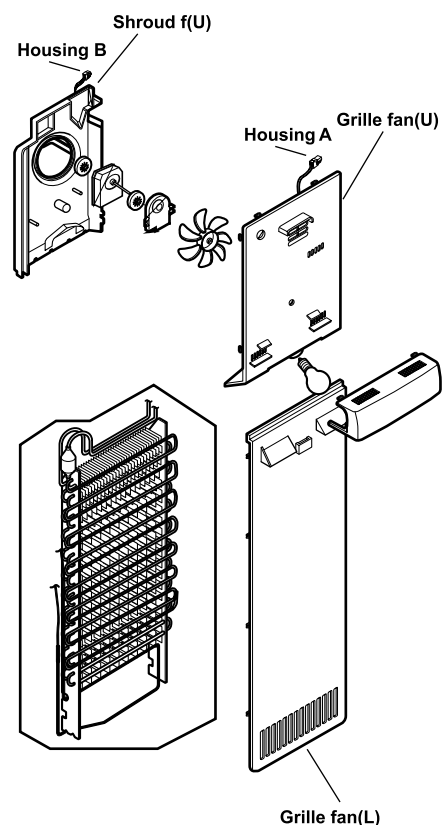

#### 4. DISPENSER

1) Disconnect funnel and button assembly by pulling down and forward.

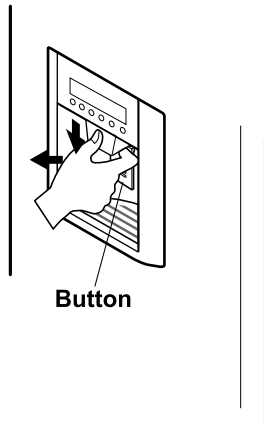

4) Loosen four screws with a phillips screwdriver and pull the funnel assembly to disconnect.

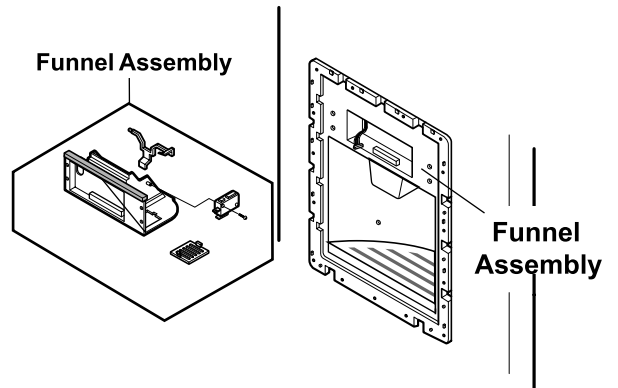

2) Remove the Display Frame moving out with both hands in one side and make the same process in the other side and pulling it forward like shows the picture.

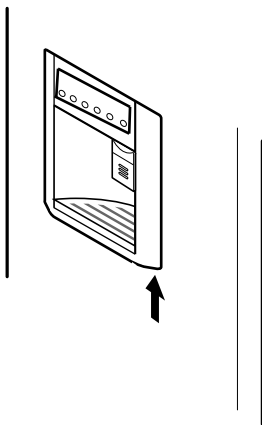

5) The Cap Duct Assembly can be disconnected if the hold lever connecting screw is loosened with a phillips driver.

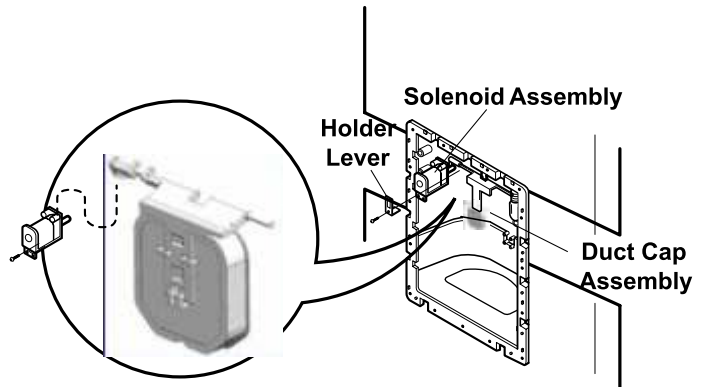

3) The Display Assembly can be connected by pressing the top of the Dispenser Cover and pushing it after separating the Display Frame from its housing.

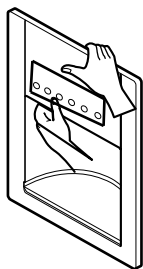

6) To install the Cap Duct Assembly, insert one end of the spring into the right hole of the dispenser lever and insert the other end into the right hole in the top part of the dispenser. Then attach the holder at the solenoid switch.

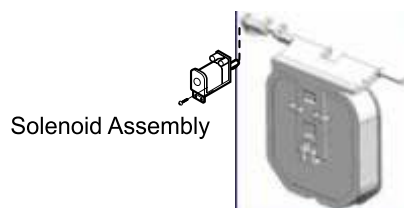



7) Dispenser Related Parts

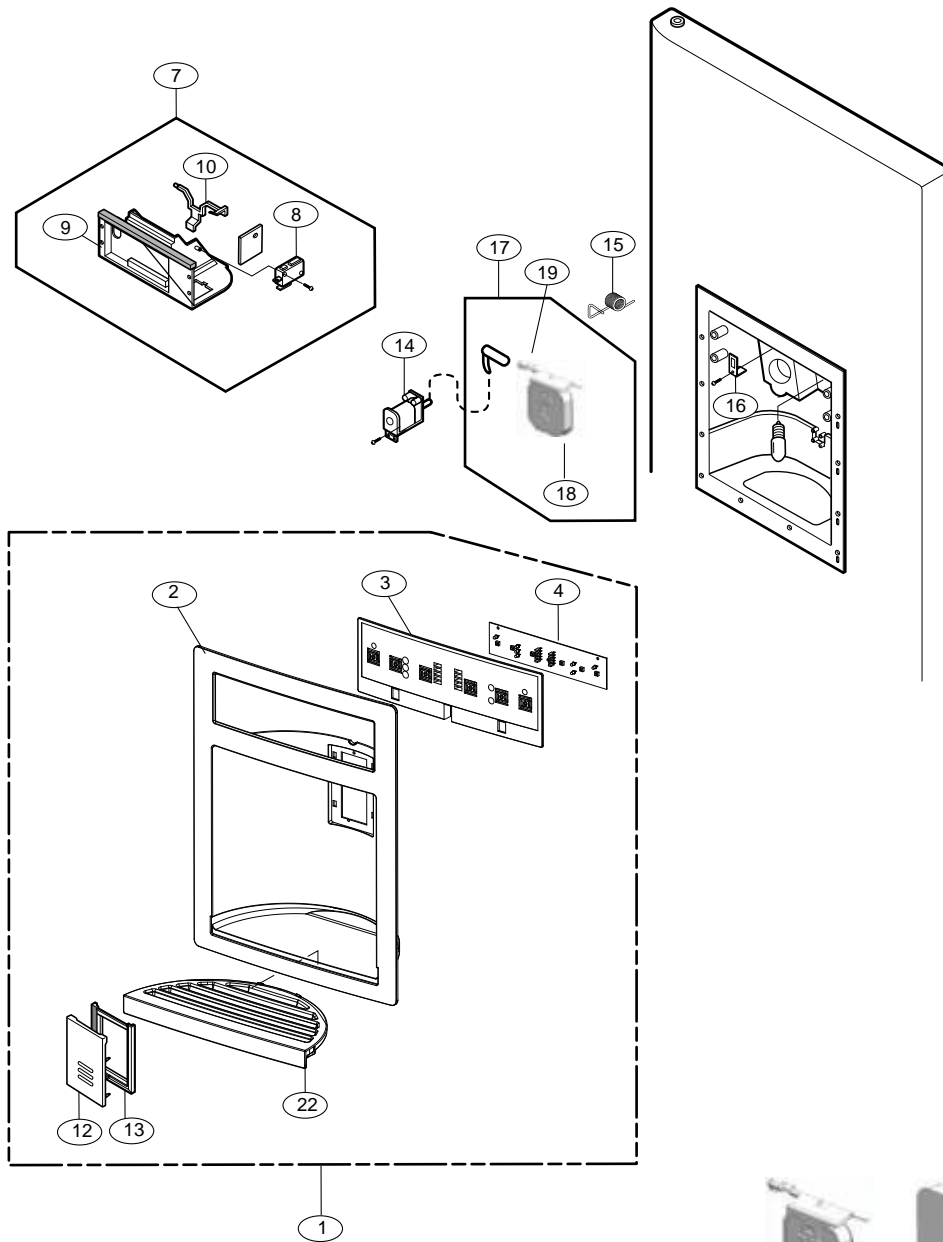

1	FRAME ASSEMBLY, DISPLAY
2	COVER, DISPENSER
3	DECO, FRAME DISPLAY
4	PWB(PCB) ASSEMBLY, DISPLAY
7	FUNNEL ASSEMBLY
8	MICRO SWITCH
9	FRAME, FUNNEL
10	LEVER(SWITCH)
11	FUNNEL
12	BUTTON LEVER
13	HOLLDER BUTTON
14	SOLENOID ASSEMBLY
15	SPRING
16	LEVER HOLDER
17	CAP ASSEMBLY, DUCT
18	CAP, DUCT
19	DISPENSER LEVER
20	FOAM, NEW
21	RUBBER, CAP
22	DECO, DRAIN



⑰ Cap Assembly, Duct Detailed Drawings

## 5. WATER-VALVE DISASSEMBLY METHOD

- 1) Turn off the power of the refrigerator (pull out the plug).  
Open the F/R Door and disassemble the Lower Cover.



- 2) Lay a dry towel on the floor and get ready to pour water from the water tank.  
Then press the collet to separate the tube from the connector and pour out the water until emptied.  
(Refer to the label attached on Front L on how to separate the tube.)

### \*Disassembly

1. Remove clip. (Retire la abrazadera)
2. Pull out tube while presiona  
(Extraiga el tubo mientras presiona los anillos metalcos y desmontelo.)

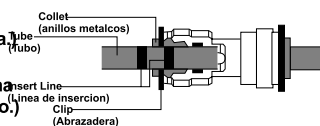

### \*Assembly

1. Insert tube until you can see only one line.  
(Inserte el tubo hasta que solo puesa ver una linea.)
2. After inserting, pull out tube to check if s properly inserted.  
(Tras insertarlo, extraiga el tubo para comprobar si ha sido insertado correctamente.)
3. Assemcic clip. (Monte la abrazadera.)



- 3) Lock the water being supplied. Then separate the Water Connection connected to the Water Valve.



- 4). Separate the Cover Back M/C and Valve Screw



- 5) Separate the housing and pull out the valve.

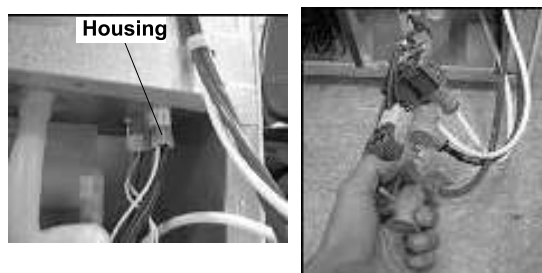

# 10. EXPLODED VIEW

## FREEZER DOOR PART

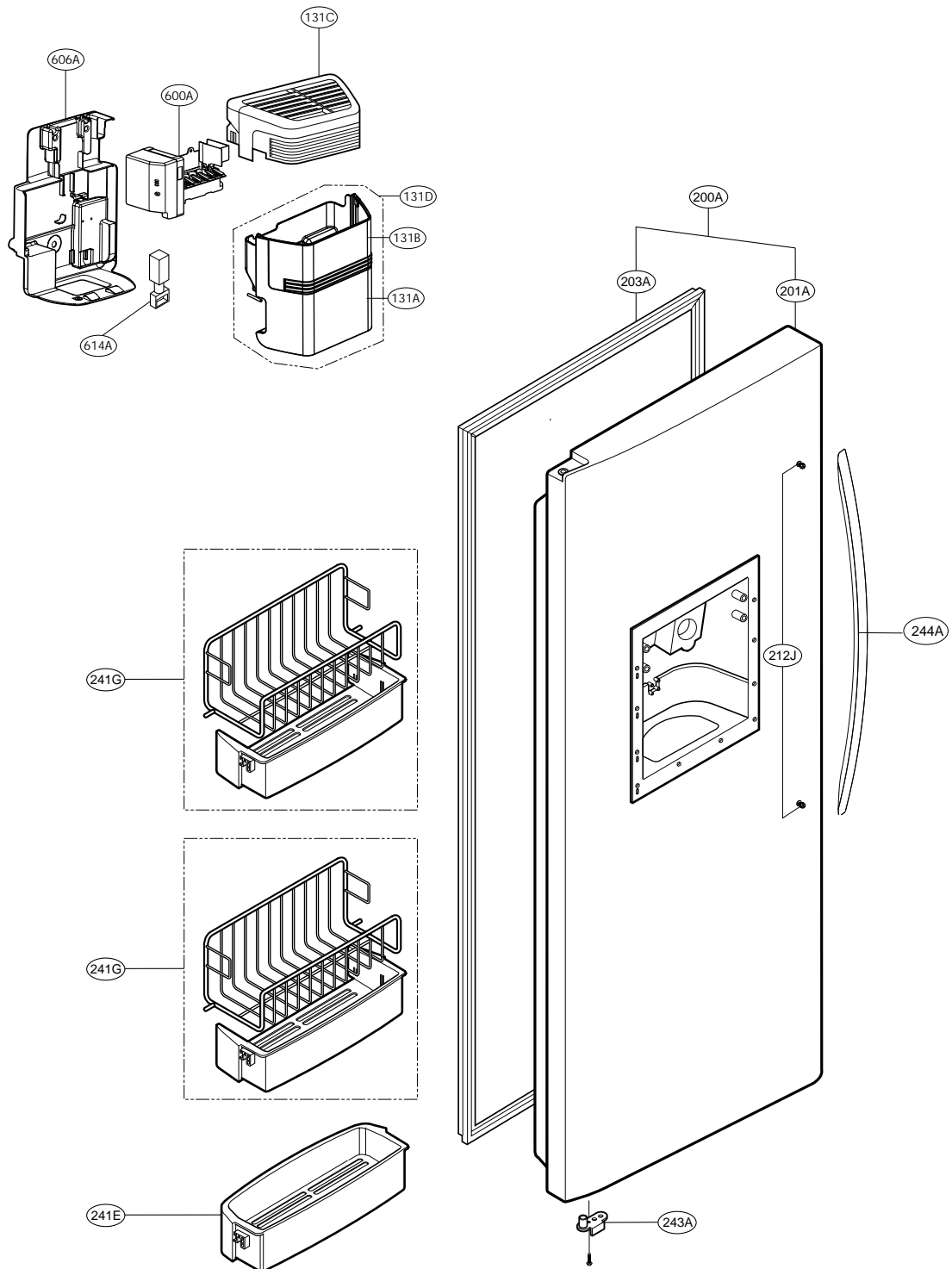

# EXPLODED VIEW

## REFRIGERATOR DOOR

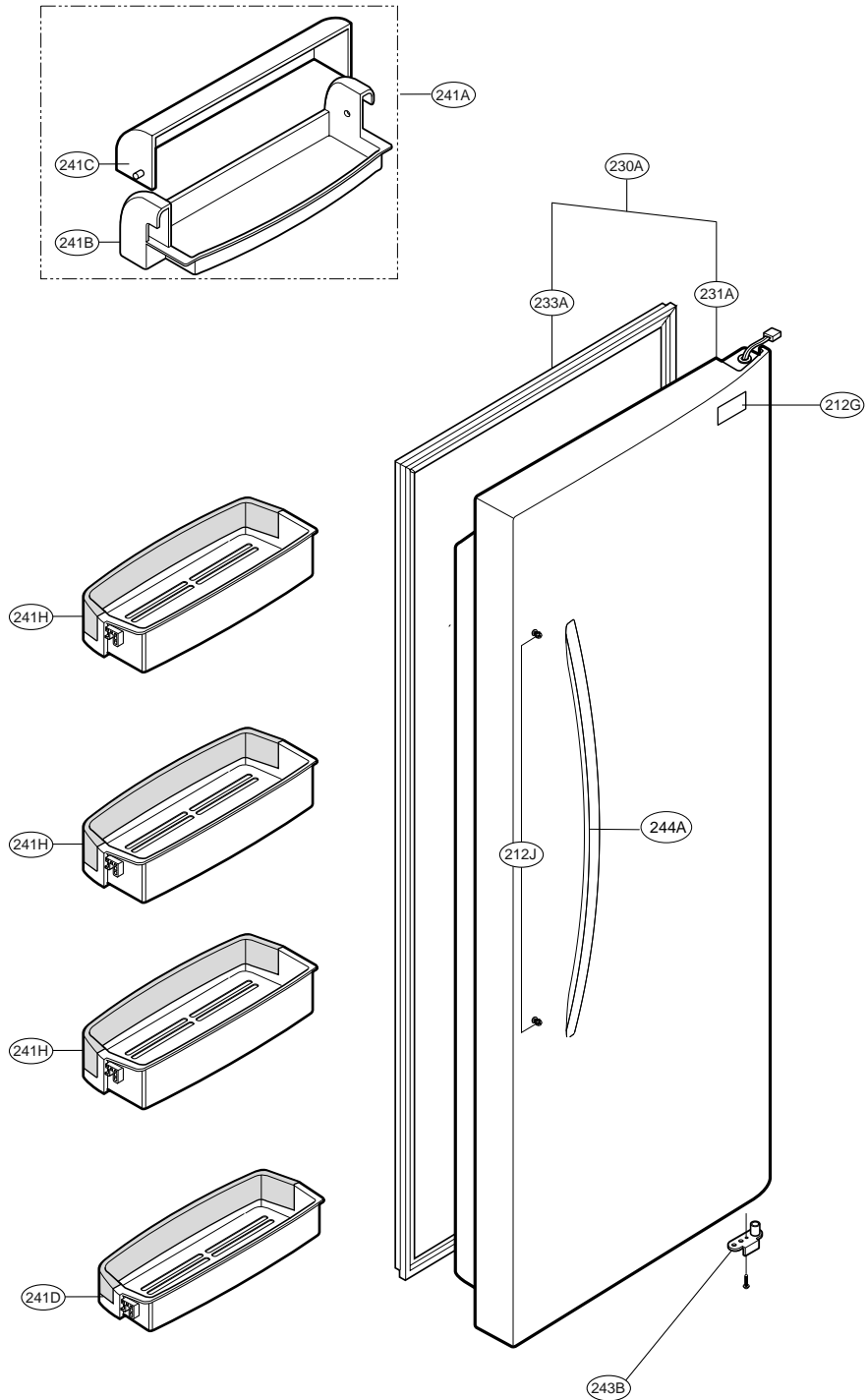

# EXPLODED VIEW

## FREEZER COMPARTMENT

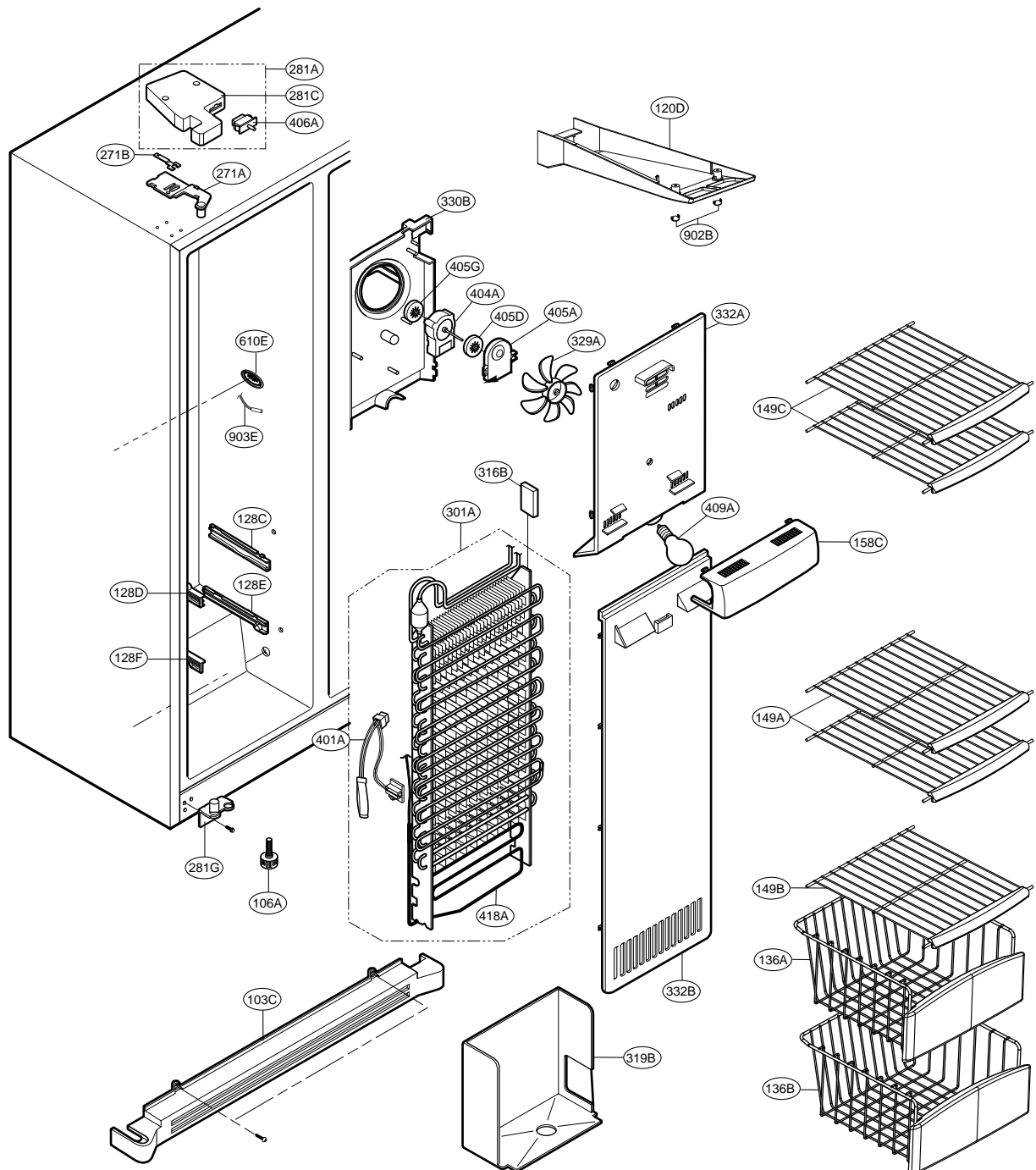

# EXPLODED VIEW

## REFRIGERATOR COMPARTMENT

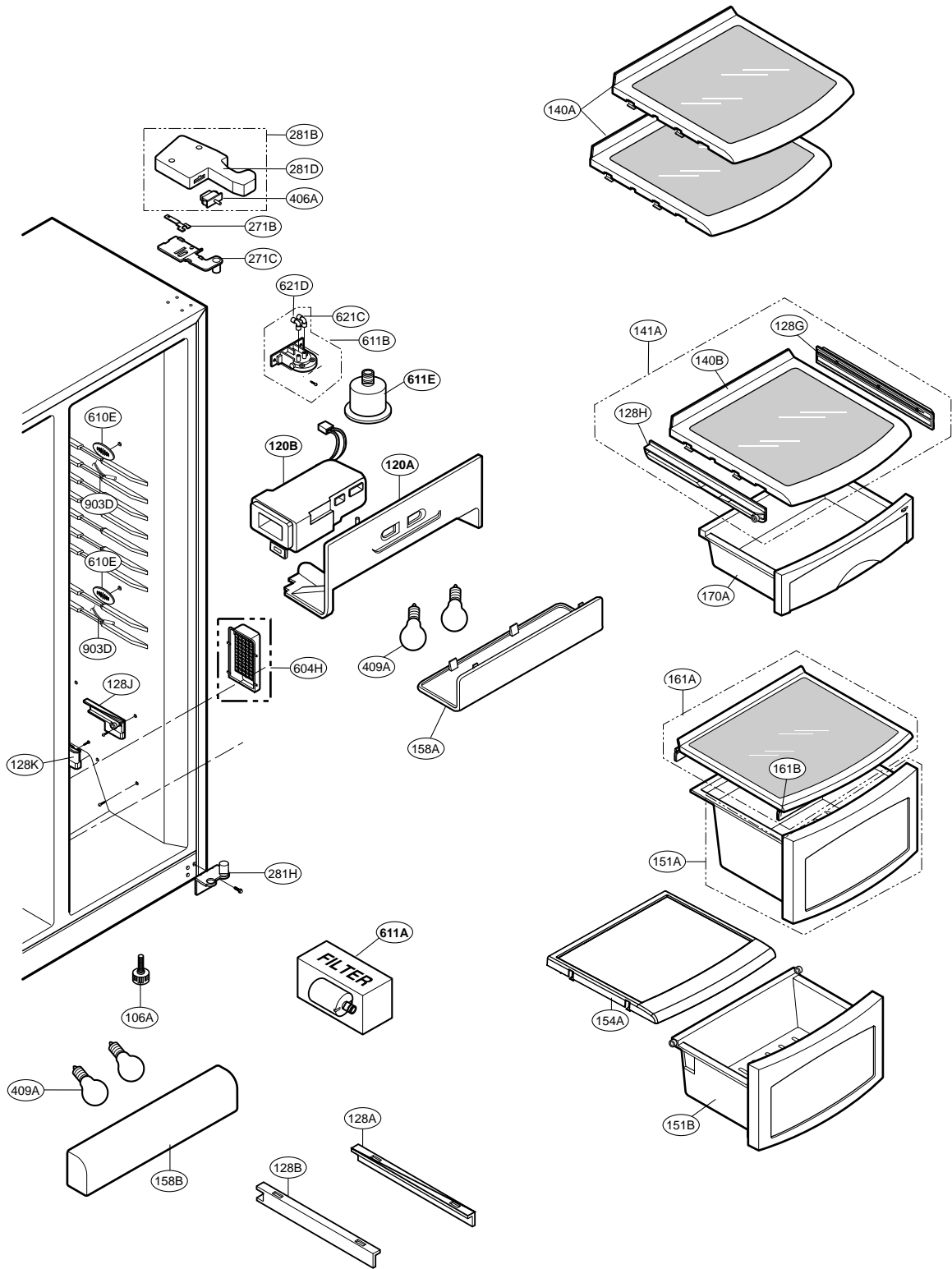

# EXPLODED VIEW

## ICE & WATER PART DISPENSER PARTS

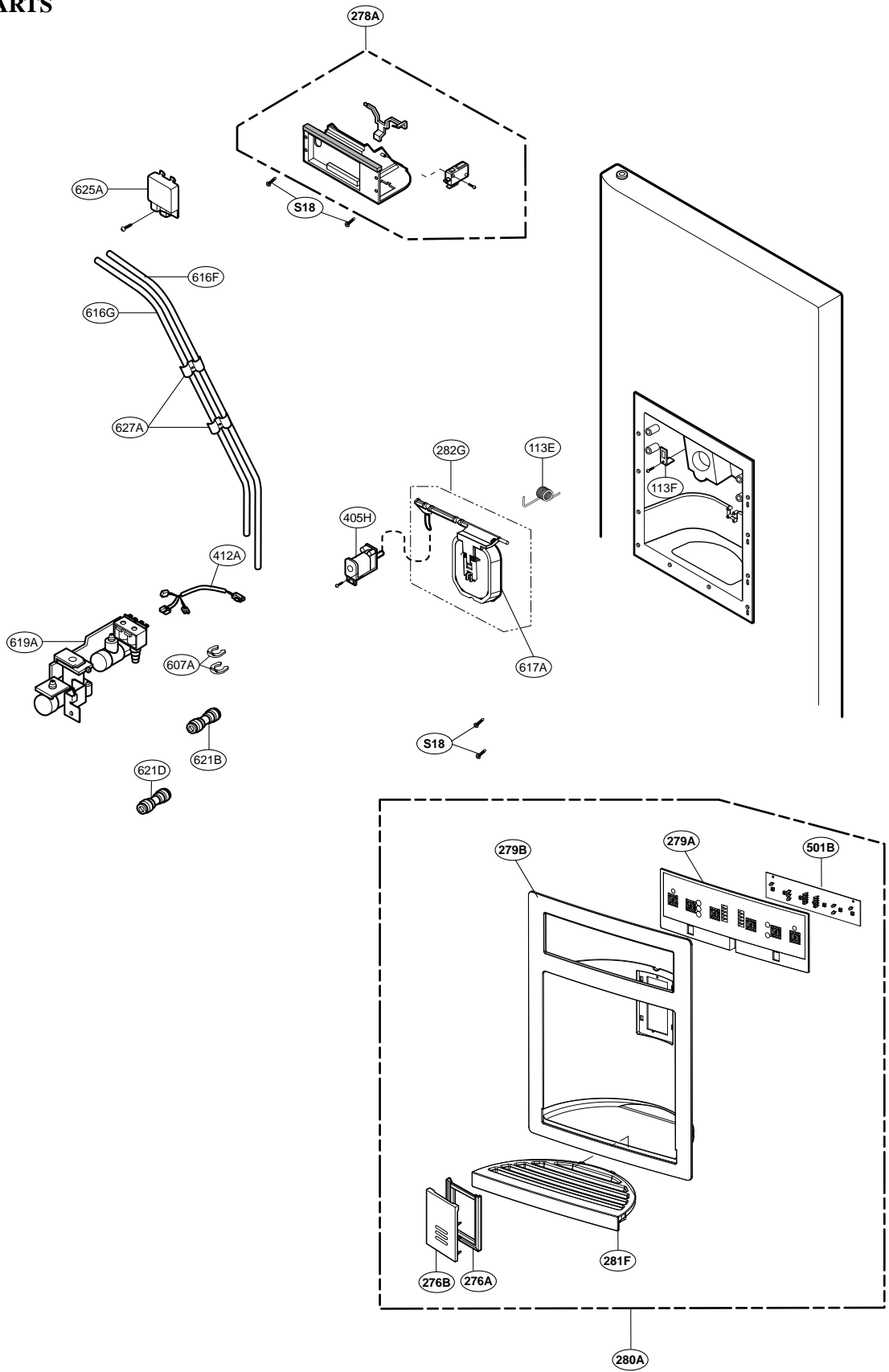

# EXPLODED VIEW

## MACHINE COMPARTMENT

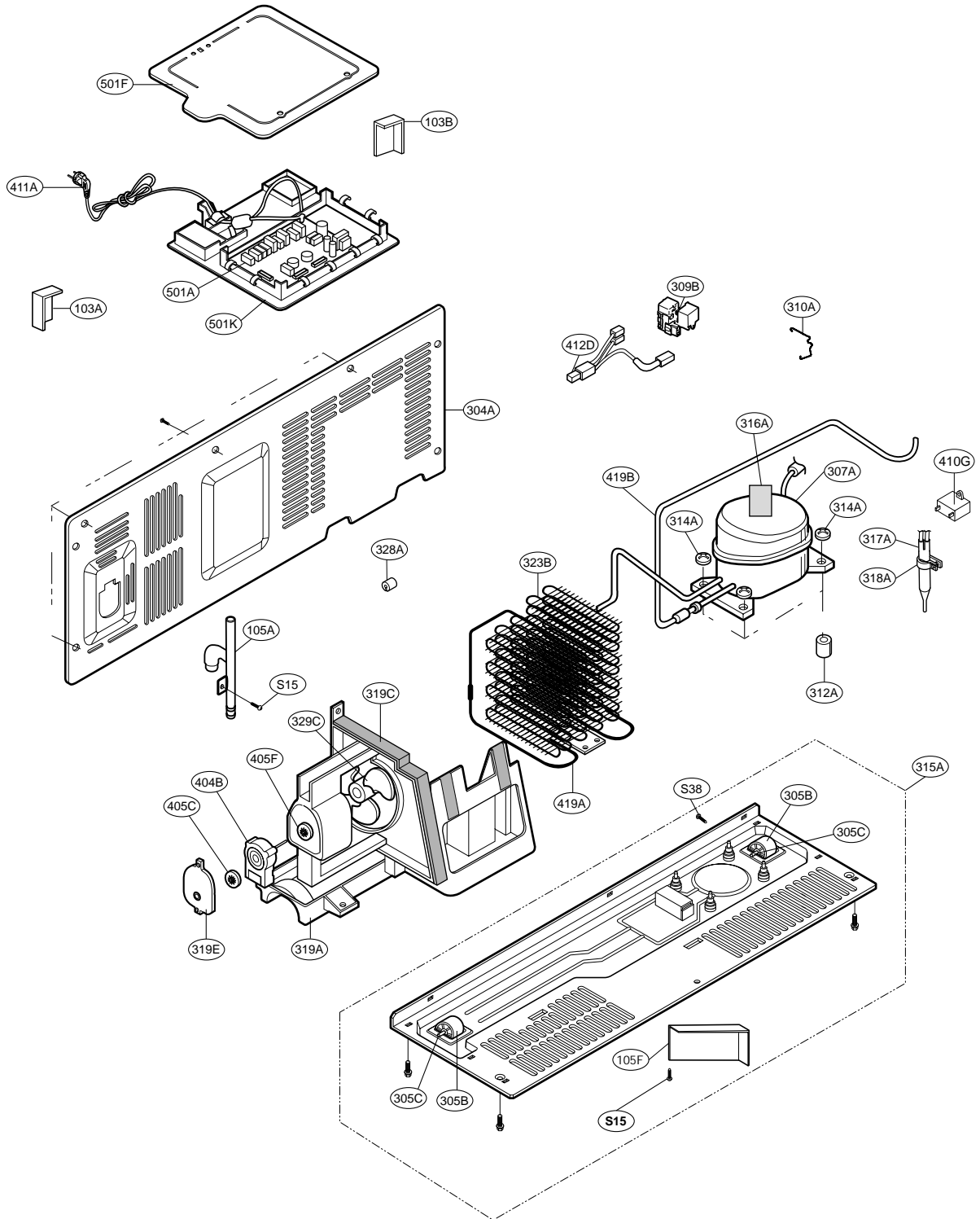



Loc No.	Part No.	Description	Loc No.	Part No.	Description
103A	3650JA3032Q	Handle,Rear	281G	4775JA2104A	Hinge Assembly,Lower
103B	3650JA3032R	Handle,Rear	281H	4775JA2113A	Hinge Assembly,Lower
103C	3550JJ0073A	Cover,Lower	282G	ABN32648401	Cap Assembly,Duct
105A	5251JA3004A	Tube Assembly,Drain	301A	ADL72916201	Evaporator Assembly
105F	5070JJ3004C	Skirt,Lower	304A	3551JA1071A	Cover Assembly,Machinery(Rear)
106A	4779JA3001E	Leg Assembly,Adjust	305B	4580JA3024B	Roller
113E	4970JA3011C	Spring,Lever	305C	1PZZJA3013A	Pin,Common
113F	4930JA3043A	Holder,Lever	307A	TCA32241801	Compressor,Set Assembly
120A	4995JJ1039B	Case Assembly,Control Refrigerator	309B	EBG44336202	Thermistor Assembly,PTC
120B	5209JJ1013B	Duct Assembly,Insulation	310A	4810JJ3033B	Bracket,Cover
120D	ADJ56976201	Duct Assembly,Multi	312A	5040JA3073A	Damper,Compressor
128A	4975JA1021A	Guide Assembly,Rail	314A	4J032777A	Stopper,Compressor
128B	4975JA1021B	Guide Assembly,Rail	315A	3103JJ1004A	BASE ASSEMBLY,COMPRESSOR
128C	4974JA1084B	Guide,Rail	316A	5072JA3003F	Damper,Noise
128D	4974JA1084A	Guide,Rail	316B	5072JA3003M	Damper,Noise
128E	4974JA1086B	Guide,Rail	317A	5851JJ2002F	Drier Assembly
128F	4974JA1086A	Guide,Rail	318A	4930JA3034A	Holder,Drier
128G	MEA40002601	Guide,Rail	319A	3390JJ1109A	Tray,Drip
128H	MEA40002602	Guide,Rail	319B	3391JA2036A	Tray Assembly,Drain
128J	4975JA1022A	Guide Assembly,Rail	319C	4974JJ1053A	Guide,Fan
128K	4975JA1022B	Guide Assembly,Rail	319E	3550JA2147A	Cover,Motor
131A	MCK51199702	Cover,Bucket Ice	323B	5403JA1003A	Condenser Assembly,Wire
131B	MKC42511501	Window,Tray	328A	4J03020A	Damper,Pipe
131C	ACQ55756501	Cover Assembly,Bucket	329A	5901JJ1018A	FAN ASSEMBLY
131D	AKC55858902	Bucket Assembly,Ice	329C	5901JJ1019A	FAN ASSEMBLY
136A	3391JJ1081A	Tray Assembly,Drawer	330B	4999JJ2004A	SHROUD ASSEMBLY,FREEZER
136B	3391JJ1081B	Tray Assembly,Drawer	332A	3531JJ1010B	Grille Assembly,Fan
140A	5027JJ1095E	Shelf Assembly,Refrigerator	332B	3531JJ1011A	GRILLE ASSEMBLY,FAN
140B	5027JJ1095F	Shelf Assembly,Refrigerator	401A	6615JB2002R	Controller Assembly
141A	AHT33603902	Shelf Assembly,Refrigerator	404A	4681JB1029A	Motor,DC
149A	5027JJ1100A	Shelf Assembly,Freezer	404B	4681JB1029B	DC Motor Assembly
149B	5027JJ1100B	Shelf Assembly,Freezer	405A	4810JA2055A	Bracket,Motor
149C	5027JJ1100H	Shelf Assembly,Freezer	405C	5040JA2004A	Damper,Motor Support
151A	3391JJ1041C	Tray Assembly,Vegetable	405D	5040JA2009B	Damper,Motor Support
151B	3391JJ1042C	Tray Assembly,Vegetable	405F	5040JA2009A	Damper,Motor Support
154A	3551JJ1067A	Cover Assembly,Tray	405G	5040JA2004B	Damper,Motor Support
158A	MCK34620601	Cover,Lamp	405H	6421JB2002D	Solenoid,Reversing,Valve
158B	3550JA1496A	Cover,Lamp	406A	6600JB3007A	Switch,Push Button
158C	MCK35849501	Cover,Lamp	406A	6600JB3007A	Switch,Push Button
161A	3551JJ1063B	Cover Assembly,Tray	409A	6912JK2002E	Lamp,Incandescent
161B	4986JA3015A	Gasket,Cover Tray	410G	0CZZJB2014G	Capacitor,Electric Appliance Film,Box
170A	3391JJ1040C	Tray Assembly,Snack	411A	EAD56779002	Power Cord Assembly
200A	ADC30116545	Door Assembly,Freezer	412A	6877JB3053D	Harness Assembly
201A	ADC30170446	Door Assembly,Semi Freezer	412D	EAD37941001	Harness Assembly
203A	4987JJ1010A	Gasket Assembly,Door	418A	5300JB1102D	Heater,Sheath
212G	3846JD1019A	Name Plate	419A	5200JA1019A	Pipe,Joint
212J	4620JJ2010C	STOPPER,HANDLE	419B	MGE58810301	Pipe,Joint
230A	ADC30116616	Door Assembly,Refrigerator	501A	EBR62357901	PCB Assembly,Main
231A	ADC30170517	Door Assembly,Semi Refrigerator	501B	EBR43358503	PCB Assembly,Display
233A	4987JJ1010B	Gasket Assembly,Door	501F	3551JA1110A	Cover Assembly,PCB
241A	5005JJ1004C	Basket Assembly,Door	501K	3110JA1071A	Case,PCB
241B	5004JJ1183A	BASKET,DOOR	600A	AEQ36756908	Ice Maker Assembly,Kit
241C	5004JJ1184A	Basket,Window	604H	3551JA2053E	Cover Assembly,Deodorizer
241D	AAP34518101	Basket Assembly,Door	606A	EAU50644302	Motor,AC
241E	5004JJ1199A	BASKET,DOOR	607A	4930JA3091A	Holder,Bracket
241G	5005JJ1003A	Basket Assembly,Door	610E	3550JA2035D	Cover,Sensor
241H	AAP34518202	Basket Assembly,Door	611A	5231JA2002A	Filter Assembly,Water
243A	4621JA3003A	Stopper Assembly,Door	611B	5231JA2004C	Filter Assembly,Head
243B	4621JA3002H	Stopper Assembly,Door	611E	5007JA3007B	Cap Assembly,Head
244A	AED37083003	Handle Assembly,Refrigerator	614A	6421JA3001Y	Solenoid,Reversing,Valve
271A	4775JA2105A	Hinge Assembly,Upper	616F	5210JA3004U	Tube,Plastic
271B	4510JA3004A	Lever,Hinge	616G	5210JA3005Q	Tube,Plastic
271C	4775JA2084A	Hinge Assembly,Upper	617A	MBL37073101	Cap,Rubber
276A	4930JA2074B	Holder,Button	619A	AJU34125513	Valve Assembly,Water
276B	5020JA2040F	Button,Lever	621B	MCD38280802	Connector,Tube
278A	ADW34028004	Funnel Assembly	621C	4932JA3009A	Connector,Tube
278G	3016JA2002C	Funnel	621D	4932JA3009B	Connector,Tube
279A	MDQ61865401	Frame,Display	625A	3550JA2184A	Cover,Tube
279B	MCK42651801	Cover,Dispenser	627A	4930JA3054A	Holder,Pipe
280A	ACQ55641807	Cover Assembly,Dispenser	902B	5006JA3123A	Cap,Duct
281A	3551JA1084D	Cover Assembly,Hinge	903D	6500JK1003A	Sensor,Temperature
281B	3551JA1084C	Cover Assembly,Hinge	903E	6500JK1004A	Sensor,Temperature
281C	3550JA1299D	Cover,Hinge	S15	4J00415D	Screw,Customized
281D	3550JA1299C	Cover,Hinge	S18	1TTG0303118	Screw,Tapping
281F	MJS42652001	Tray,Drain	S38	4000W4A003A	Screw,Customized

Loc No.	Part No.	Description	Loc No.	Part No.	Description
103A	3650JA3041W	Handle,Rear	281G	4775JA2104A	Hinge Assembly,Lower
103B	3650JA3041X	Handle,Rear	281H	4775JA2113A	Hinge Assembly,Lower
103C	3550JJ0073B	Cover,Lower	282G	ABN32648401	Cap Assembly,Duct
105A	5251JA3004A	Tube Assembly,Drain	301A	ADL72916201	Evaporator Assembly
105F	5070JJ3004C	Skirt,Lower	304A	3551JA1071A	Cover Assembly,Machinery(Rear)
106A	4779JA3001E	Leg Assembly,Adjust	305B	4580JA3024B	Roller
113E	4970JA3011C	Spring,Lever	305C	1PZZJA3013A	Pin,Common
113F	4930JA3043A	Holder,Lever	307A	TCA32241801	Compressor,Set Assembly
120A	4995JJ1039B	Case Assembly,Control Refrigerator	309B	EBG44336202	Thermistor Assembly,PTC
120B	5209JJ1013B	Duct Assembly,Insulation	310A	4810JJ3033B	Bracket,Cover
120D	ADJ56976201	Duct Assembly,Multi	312A	5040JA3073A	Damper,Compressor
128A	4975JA1021A	Guide Assembly,Rail	314A	4J03277A	Stopper,Compressor
128B	4975JA1021B	Guide Assembly,Rail	315A	3103JJ1004A	BASE ASSEMBLY,COMPRESSOR
128C	4974JA1084B	Guide,Rail	316A	5072JA3003F	Damper,Noise
128D	4974JA1084A	Guide,Rail	316B	5072JA3003M	Damper,Noise
128E	4974JA1086B	Guide,Rail	317A	5851JJ2002F	Drier Assembly
128F	4974JA1086A	Guide,Rail	318A	4930JA3034A	Holder,Drier
128G	MEA40002601	Guide,Rail	319A	3390JJ1109A	Tray,Drip
128H	MEA40002602	Guide,Rail	319B	3391JA2036A	Tray Assembly,Drain
128J	4975JA1022A	Guide Assembly,Rail	319C	4974JJ1053A	Guide,Fan
128K	4975JA1022B	Guide Assembly,Rail	319E	3550JA2147A	Cover,Motor
131A	MCK51199702	Cover,Bucket Ice	323B	5403JA1003A	Condenser Assembly,Wire
131B	MKC42511501	Window,Tray	328A	4J03020A	Damper,Pipe
131C	ACQ55756501	Cover Assembly,Bucket	329A	5901JJ1018A	FAN ASSEMBLY
131D	AKC55858902	Bucket Assembly,Ice	329C	5901JJ1019A	FAN ASSEMBLY
136A	3391JJ1081A	Tray Assembly,Drawer	330B	4999JJ2004A	SHROUD ASSEMBLY,FREEZER
136B	3391JJ1081B	Tray Assembly,Drawer	332A	3531JJ1010B	Grille Assembly,Fan
140A	5027JJ1095E	Shelf Assembly,Refrigerator	332B	3531JJ1011A	GRILLE ASSEMBLY,FAN
140B	5027JJ1095F	Shelf Assembly,Refrigerator	401A	6615JB2002R	Controller Assembly
141A	AHT33603902	Shelf Assembly,Refrigerator	404A	4681JB1029A	Motor,DC
149A	5027JJ1100A	Shelf Assembly,Freezer	404B	4681JB1029B	DC Motor Assembly
149B	5027JJ1100B	Shelf Assembly,Freezer	405A	4810JA2055A	Bracket,Motor
149C	5027JJ1100H	Shelf Assembly,Freezer	405C	5040JA2004A	Damper,Motor Support
151A	3391JJ1041C	Tray Assembly,Vegetable	405D	5040JA2009B	Damper,Motor Support
151B	3391JJ1042C	Tray Assembly,Vegetable	405F	5040JA2009A	Damper,Motor Support
154A	3551JJ1067A	Cover Assembly,Tray	405G	5040JA2004B	Damper,Motor Support
158A	MCK34620601	Cover,Lamp	405H	6421JB2002D	Solenoid,Reversing,Valve
158B	3550JA1496A	Cover,Lamp	406A	6600JB3007B	Switch,Push Button
158C	MCK35849501	Cover,Lamp	406A	6600JB3007B	Switch,Push Button
161A	3551JJ1063B	Cover Assembly,Tray	409A	6912JK2002E	Lamp,Incandescent
161B	4986JA3015A	Gasket,Cover Tray	410G	0CZZJB2014G	Capacitor,Electric Appliance Film,Box
170A	3391JJ1040C	Tray Assembly,Snack	411A	EAD56779002	Power Cord Assembly
200A	ADC30116544	Door Assembly,Freezer	412A	6877JB3053D	Harness Assembly
201A	ADC30170445	Door Assembly,Semi Freezer	412D	EAD37941001	Harness Assembly
203A	4987JJ1010E	Gasket Assembly,Door	418A	5300JB1102D	Heater,Sheath
212G	3846JD1019A	Name Plate	419A	5200JA1019A	Pipe,Joint
212J	4620JJ2010C	STOPPER,HANDLE	419B	MGE58810301	Pipe,Joint
230A	ADC30116615	Door Assembly,Refrigerator	501A	EBR62357901	PCB Assembly,Main
231A	ADC30170516	Door Assembly,Semi Refrigerator	501B	EBR43358503	PCB Assembly,Display
233A	4987JJ1010F	Gasket Assembly,Door	501F	3551JA1110B	Cover Assembly,PCB
241A	5005JJ1004C	Basket Assembly,Door	501K	3110JA1071A	Case,PCB
241B	5004JJ1183A	BASKET,DOOR	600A	AEQ36756908	Ice Maker Assembly,Kit
241C	5004JJ1184A	Basket,Window	604H	3551JA2053E	Cover Assembly,Deodorizer
241D	AAP34518101	Basket Assembly,Door	606A	EAU50644302	Motor,AC
241E	5004JJ1199A	BASKET,DOOR	607A	4930JA3091A	Holder,Bracket
241G	5005JJ1003A	Basket Assembly,Door	610E	3550JA2035D	Cover,Sensor
241H	AAP34518202	Basket Assembly,Door	611A	5231JA2002A	Filter Assembly,Water
243A	4621JA3003A	Stopper Assembly,Door	611B	5231JA2004C	Filter Assembly,Head
243B	4621JA3002H	Stopper Assembly,Door	611E	5007JA3007B	Cap Assembly,Head
244A	AED37083001	Handle Assembly,Refrigerator	614A	6421JA3001Y	Solenoid,Reversing,Valve
271A	4775JA2105A	Hinge Assembly,Upper	616F	5210JA3004U	Tube,Plastic
271B	4510JA3004A	Lever,Hinge	616G	5210JA3005Q	Tube,Plastic
271C	4775JA2084A	Hinge Assembly,Upper	617A	MBL37073101	Cap,Rubber
276A	4930JA2074B	Holder,Button	619A	AJU34125513	Valve Assembly,Water
276B	5020JA2040E	Button,Lever	621B	MCD38280802	Connector,Tube
278A	ADW34028004	Funnel Assembly	621C	4932JA3009A	Connector,Tube
278G	3016JA2002K	Funnel	621D	4932JA3009B	Connector,Tube
279A	MDQ61865401	Frame,Display	625A	3550JA2184A	Cover,Tube
279B	MCK62031301	Cover,Dispenser	627A	4930JA3054A	Holder,Pipe
280A	ACQ55641810	Cover Assembly,Dispenser	902B	5006JA3123A	Cap,Duct
281A	3551JA1084F	Cover Assembly,Hinge	903D	6500JK1003A	Sensor,Temperature
281B	3551JA1084E	Cover Assembly,Hinge	903E	6500JK1004A	Sensor,Temperature
281C	3550JA1299F	Cover,Hinge	S15	4J00415D	Screw,Customized
281D	3550JA1299E	Cover,Hinge	S18	1TTG0303118	Screw,Tapping
281F	MJS42652003	Tray,Drain	S38	4000W4A003A	Screw,Customized

Loc No.	Part No.	Description	Loc No.	Part No.	Description
103A	3650JA3041W	Handle,Rear	281G	4775JA2104A	Hinge Assembly,Lower
103B	3650JA3041X	Handle,Rear	281H	4775JA2113A	Hinge Assembly,Lower
103C	3550JJ0073B	Cover,Lower	282G	ABN32648401	Cap Assembly,Duct
105A	5251JA3004A	Tube Assembly,Drain	301A	ADL72916201	Evaporator Assembly
105F	5070JJ3004C	Skirt,Lower	304A	3551JA1071A	Cover Assembly,Machinery(Rear)
106A	4779JA3001E	Leg Assembly,Adjust	305B	4580JA3024B	Roller
113E	4970JA3011C	Spring,Lever	305C	1PZZJA3013A	Pin,Common
113F	4930JA3043A	Holder,Lever	307A	TCA32241801	Compressor,Set Assembly
120A	4995JJ1039B	Case Assembly,Control Refrigerator	309B	EBG44336202	Thermistor Assembly,PTC
120B	5209JJ1013B	Duct Assembly,Insulation	310A	4810JJ3033B	Bracket,Cover
120D	ADJ56976201	Duct Assembly,Multi	312A	5040JA3073A	Damper,Compressor
128A	4975JA1021A	Guide Assembly,Rail	314A	4J03277A	Stopper,Compressor
128B	4975JA1021B	Guide Assembly,Rail	315A	3103JJ1004A	BASE ASSEMBLY,COMPRESSOR
128C	4974JA1084B	Guide,Rail	316A	5072JA3003F	Damper,Noise
128D	4974JA1084A	Guide,Rail	316B	5072JA3003M	Damper,Noise
128E	4974JA1086B	Guide,Rail	317A	5851JJ2002F	Drier Assembly
128F	4974JA1086A	Guide,Rail	318A	4930JA3034A	Holder,Drier
128G	MEA40002601	Guide,Rail	319A	3390JJ1109A	Tray,Drip
128H	MEA40002602	Guide,Rail	319B	3391JA2036A	Tray Assembly,Drain
128J	4975JA1022A	Guide Assembly,Rail	319C	4974JJ1053A	Guide,Fan
128K	4975JA1022B	Guide Assembly,Rail	319E	3550JA2147A	Cover,Motor
131A	MCK51199702	Cover,Bucket Ice	323B	5403JA1003A	Condenser Assembly,Wire
131B	MKC42511501	Window,Tray	328A	4J03020A	Damper,Pipe
131C	ACQ55756501	Cover Assembly,Bucket	329A	5901JJ1018A	FAN ASSEMBLY
131D	AKC55858902	Bucket Assembly,Ice	329C	5901JJ1019A	FAN ASSEMBLY
136A	3391JJ1081A	Tray Assembly,Drawer	330B	4999JJ2004A	SHROUD ASSEMBLY,FREEZER
136B	3391JJ1081B	Tray Assembly,Drawer	332A	3531JJ1010B	Grille Assembly,Fan
140A	5027JJ1095E	Shelf Assembly,Refrigerator	332B	3531JJ1011A	GRILLE ASSEMBLY,FAN
140B	5027JJ1095F	Shelf Assembly,Refrigerator	401A	6615JB2002R	Controller Assembly
141A	AHT33603902	Shelf Assembly,Refrigerator	404A	4681JB1029A	Motor,DC
149A	5027JJ1100A	Shelf Assembly,Freezer	404B	4681JB1029B	DC Motor Assembly
149B	5027JJ1100B	Shelf Assembly,Freezer	405A	4810JA2055A	Bracket,Motor
149C	5027JJ1100H	Shelf Assembly,Freezer	405C	5040JA2004A	Damper,Motor Support
151A	3391JJ1041C	Tray Assembly,Vegetable	405D	5040JA2009B	Damper,Motor Support
151B	3391JJ1042C	Tray Assembly,Vegetable	405F	5040JA2009A	Damper,Motor Support
154A	3551JJ1067A	Cover Assembly,Tray	405G	5040JA2004B	Damper,Motor Support
158A	MCK34620601	Cover,Lamp	405H	6421JB2002D	Solenoid,Reversing,Valve
158B	3550JA1496A	Cover,Lamp	406A	6600JB3007B	Switch,Push Button
158C	MCK35849501	Cover,Lamp	406A	6600JB3007B	Switch,Push Button
161A	3551JJ1063B	Cover Assembly,Tray	409A	6912JK2002E	Lamp,Incandescent
161B	4986JA3015A	Gasket,Cover Tray	410G	OCZZJB2014G	Capacitor,Electric Appliance Film,Box
170A	3391JJ1040C	Tray Assembly,Snack	411A	EAD56779002	Power Cord Assembly
200A	ADC30116546	Door Assembly,Freezer	412A	6877JB3053D	Harness Assembly
201A	ADC30170448	Door Assembly,Semi Freezer	412D	EAD37941001	Harness Assembly
203A	4987JJ1010E	Gasket Assembly,Door	418A	5300JB1102D	Heater,Sheath
212G	3846JD1019A	Name Plate	419A	5200JA1019A	Pipe,Joint
212J	4620JJ2010C	STOPPER,HANDLE	419B	MGE58810301	Pipe,Joint
230A	ADC30116634	Door Assembly,Refrigerator	501A	EBR62357901	PCB Assembly,Main
231A	ADC30170526	Door Assembly,Semi Refrigerator	501B	EBR43358503	PCB Assembly,Display
233A	4987JJ1010F	Gasket Assembly,Door	501F	3551JA1110B	Cover Assembly,PCB
241A	5005JJ1004C	Basket Assembly,Door	501K	3110JA1071A	Case,PCB
241B	5004JJ1183A	BASKET,DOOR	600A	AEQ36756908	Ice Maker Assembly,Kit
241C	5004JJ1184A	Basket,Window	604H	3551JA2053E	Cover Assembly,Deodorizer
241D	AAP34518101	Basket Assembly,Door	606A	EAU50644302	Motor,AC
241E	5004JJ1199A	BASKET,DOOR	607A	4930JA3091A	Holder,Bracket
241G	5005JJ1003A	Basket Assembly,Door	610E	3550JA2035D	Cover,Sensor
241H	AAP34518202	Basket Assembly,Door	611A	5231JA2002A	Filter Assembly,Water
243A	4621JA3003A	Stopper Assembly,Door	611B	5231JA2004C	Filter Assembly,Head
243B	4621JA3002H	Stopper Assembly,Door	611E	5007JA3007B	Cap Assembly,Head
244A	AED37083001	Handle Assembly,Refrigerator	614A	6421JA3001Y	Solenoid,Reversing,Valve
271A	4775JA2105A	Hinge Assembly,Upper	616F	5210JA3004U	Tube,Plastic
271B	4510JA3004A	Lever,Hinge	616G	5210JA3005Q	Tube,Plastic
271C	4775JA2084A	Hinge Assembly,Upper	617A	MBL37073101	Cap,Rubber
276A	4930JA2074B	Holder,Button	619A	AJU34125513	Valve Assembly,Water
276B	5020JA2040E	Button,Lever	621B	MCD38280802	Connector,Tube
278A	ADW34028004	Funnel Assembly	621C	4932JA3009A	Connector,Tube
278G	3016JA2002K	Funnel	621D	4932JA3009B	Connector,Tube
279A	MDQ61865401	Frame,Display	625A	3550JA2184A	Cover,Tube
279B	MCK42651803	Cover,Dispenser	627A	4930JA3054A	Holder,Pipe
280A	ACQ55641809	Cover Assembly,Dispenser	902B	5006JA3123A	Cap,Duct
281A	3551JA1084F	Cover Assembly,Hinge	903D	6500JK1003A	Sensor,Temperature
281B	3551JA1084E	Cover Assembly,Hinge	903E	6500JK1004A	Sensor,Temperature
281C	3550JA1299F	Cover,Hinge	S15	4J00415D	Screw,Customized
281D	3550JA1299E	Cover,Hinge	S18	1TTG0303118	Screw,Tapping
281F	MJS42652003	Tray,Drain	S38	4000W4A003A	Screw,Customized

Loc No.	Part No.	Description	Loc No.	Part No.	Description
103A	3650JA3041Y	Handle,Rear	281G	4775JA2104A	Hinge Assembly,Lower
103B	3650JA3041Z	Handle,Rear	281H	4775JA2113A	Hinge Assembly,Lower
103C	3550JJ0073D	Cover,Lower	282G	ABN32648401	Cap Assembly,Duct
105A	5251JA3004A	Tube Assembly,Drain	301A	ADL72916201	Evaporator Assembly
105F	5070JJ3004C	Skirt,Lower	304A	3551JA1071A	Cover Assembly,Machinery(Rear)
106A	4779JA3001E	Leg Assembly,Adjust	305B	4580JA3024B	Roller
113E	4970JA3011C	Spring,Lever	305C	1PZZJA3013A	Pin,Common
113F	4930JA3043A	Holder,Lever	307A	TCA32241801	Compressor,Set Assembly
120A	4995JJ1039B	Case Assembly,Control Refrigerator	309B	EBG44336202	Thermistor Assembly,PTC
120B	5209JJ1013B	Duct Assembly,Insulation	310A	4810JJ3033B	Bracket,Cover
120D	ADJ56976201	Duct Assembly,Multi	312A	5040JA3073A	Damper,Compressor
128A	4975JA1021A	Guide Assembly,Rail	314A	4J03277A	Stopper,Compressor
128B	4975JA1021B	Guide Assembly,Rail	315A	3103JJ1004A	BASE ASSEMBLY,COMPRESSOR
128C	4974JA1084B	Guide,Rail	316A	5072JA3003F	Damper,Noise
128D	4974JA1084A	Guide,Rail	316B	5072JA3003M	Damper,Noise
128E	4974JA1086B	Guide,Rail	317A	5851JJ2002F	Drier Assembly
128F	4974JA1086A	Guide,Rail	318A	4930JA3034A	Holder,Drier
128G	MEA40002601	Guide,Rail	319A	3390JJ1109A	Tray,Drip
128H	MEA40002602	Guide,Rail	319B	3391JA2036A	Tray Assembly,Drain
128J	4975JA1022A	Guide Assembly,Rail	319C	4974JJ1053A	Guide,Fan
128K	4975JA1022B	Guide Assembly,Rail	319E	3550JA2147A	Cover,Motor
131A	MCK51199702	Cover,Bucket Ice	323B	5403JA1003A	Condenser Assembly,Wire
131B	MKC42511501	Window,Tray	328A	4J03020A	Damper,Pipe
131C	ACQ55756501	Cover Assembly,Bucket	329A	5901JJ1018A	FAN ASSEMBLY
131D	AKC55858902	Bucket Assembly,Ice	329C	5901JJ1019A	FAN ASSEMBLY
136A	3391JJ1081A	Tray Assembly,Drawer	330B	4999JJ2004A	SHROUD ASSEMBLY,FREEZER
136B	3391JJ1081B	Tray Assembly,Drawer	332A	3531JJ1010B	Grille Assembly,Fan
140A	5027JJ1095E	Shelf Assembly,Refrigerator	332B	3531JJ1011A	GRILLE ASSEMBLY,FAN
140B	5027JJ1095F	Shelf Assembly,Refrigerator	401A	6615JB2002R	Controller Assembly
141A	AHT33603902	Shelf Assembly,Refrigerator	404A	4681JB1029A	Motor,DC
149A	5027JJ1100A	Shelf Assembly,Freezer	404B	4681JB1029B	DC Motor Assembly
149B	5027JJ1100B	Shelf Assembly,Freezer	405A	4810JA2055A	Bracket,Motor
149C	5027JJ1100H	Shelf Assembly,Freezer	405C	5040JA2004A	Damper,Motor Support
151A	3391JJ1041C	Tray Assembly,Vegetable	405D	5040JA2009B	Damper,Motor Support
151B	3391JJ1042C	Tray Assembly,Vegetable	405F	5040JA2009A	Damper,Motor Support
154A	3551JJ1067A	Cover Assembly,Tray	405G	5040JA2004B	Damper,Motor Support
158A	MCK34620601	Cover,Lamp	405H	6421JB2002D	Solenoid,Reversing, Valve
158B	3550JA1496A	Cover,Lamp	406A	6600JB3007E	Switch,Push Button
158C	MCK35849501	Cover,Lamp	406A	6600JB3007E	Switch,Push Button
161A	3551JJ1063B	Cover Assembly,Tray	409A	6912JK2002E	Lamp,Incandescent
161B	4986JA3015A	Gasket,Cover Tray	410G	0CZZJB2014G	Capacitor,Electric Appliance Film,Box
170A	3391JJ1040C	Tray Assembly,Snack	411A	EAD56779002	Power Cord Assembly
200A	ADC30116546	Door Assembly,Freezer	412A	6877JB3053D	Harness Assembly
201A	ADC30170447	Door Assembly,Semi Freezer	412D	EAD37941001	Harness Assembly
203A	4987JJ1010C	Gasket Assembly,Door	418A	5300JB1102D	Heater,Sheath
212G	3846JD1019A	Name Plate	419A	5200JA1019A	Pipe,Joint
212J	4620JJ2010C	STOPPER,HANDLE	419B	MGE58810301	Pipe,Joint
230A	ADC30116634	Door Assembly,Refrigerator	501A	EBR62357901	PCB Assembly,Main
231A	ADC30170537	Door Assembly,Semi Refrigerator	501B	EBR43358503	PCB Assembly,Display
233A	4987JJ1010D	Gasket Assembly,Door	501F	3551JA1110D	Cover Assembly,PCB
241A	5005JJ1004C	Basket Assembly,Door	501K	3110JA1071A	Case,PCB
241B	5004JJ1183A	BASKET,DOOR	600A	AEQ36756908	Ice Maker Assembly,Kit
241C	5004JJ1184A	Basket,Window	604H	3551JA2053E	Cover Assembly,Deodorizer
241D	AAP34518101	Basket Assembly,Door	606A	EAU50644302	Motor,AC
241E	5004JJ1199A	BASKET,DOOR	607A	4930JA3091A	Holder,Bracket
241G	5005JJ1003A	Basket Assembly,Door	610E	3550JA2035D	Cover,Sensor
241H	AAP34518202	Basket Assembly,Door	611A	5231JA2002A	Filter Assembly,Water
243A	4621JA3003A	Stopper Assembly,Door	611B	5231JA2004C	Filter Assembly,Head
243B	4621JA3002H	Stopper Assembly,Door	611E	5007JA3007B	Cap Assembly,Head
244A	AED37083002	Handle Assembly,Refrigerator	614A	6421JA3001Y	Solenoid,Reversing, Valve
271A	4775JA2105A	Hinge Assembly,Upper	616F	5210JA3004U	Tube,Plastic
271B	4510JA3004A	Lever,Hinge	616G	5210JA3005Q	Tube,Plastic
271C	4775JA2084A	Hinge Assembly,Upper	617A	MBL37073101	Cap,Rubber
276A	4930JA2074B	Holder,Button	619A	AJU34125513	Valve Assembly,Water
276B	5020JA2040K	Button,Lever	621B	MCD38280802	Connector,Tube
278A	ADW34028005	Funnel Assembly	621C	4932JA3009A	Connector,Tube
278G	3016JA2002G	Funnel	621D	4932JA3009B	Connector,Tube
279A	MDQ61865401	Frame,Display	625A	3550JA2184A	Cover,Tube
279B	MCK42651802	Cover,Dispenser	627A	4930JA3054A	Holder,Pipe
280A	ACQ55641808	Cover Assembly,Dispenser	902B	5006JA3123A	Cap,Duct
281A	3551JA1084H	Cover Assembly,Hinge	903D	6500JK1003A	Sensor,Temperature
281B	3551JA1084G	Cover Assembly,Hinge	903E	6500JK1004A	Sensor,Temperature
281C	3550JA1299G	Cover,Hinge	S15	4J00415D	Screw,Customized
281D	3550JA1299H	Cover,Hinge	S18	1TTG0303118	Screw,Tapping
281F	MJS42652002	Tray,Drain	S38	4000W4A003A	Screw,Customized



*'You Can Count on me . . .  
to Work Safely.'*