

This Owner's Manual is provided and hosted by [Appliance Factory Parts](#).



FIELD CONTROLS TM-90R Owner's Manual

[Shop genuine replacement parts for FIELD CONTROLS
TM-90R](#)



[Find Your FIELD CONTROLS Humidifier Parts - Select From 14 Models](#)

----- Manual continues below -----

TM-90R/TM-2000 HUMIDISTAT INSTALLATION INSTRUCTIONS

CAUTION: DISCONNECT THE TM-90R/TM-2000 TRANSFORMER FROM THE RECEPTACLE AND SWITCH "OFF" THE FURNACE ELECTRICAL SUPPLY PRIOR TO INSTALLING THIS HUMIDISTAT.

1. Remove Humidity Control from front side of Base Plate and re-attach to back side of Base Plate. The Adjustment Knob must

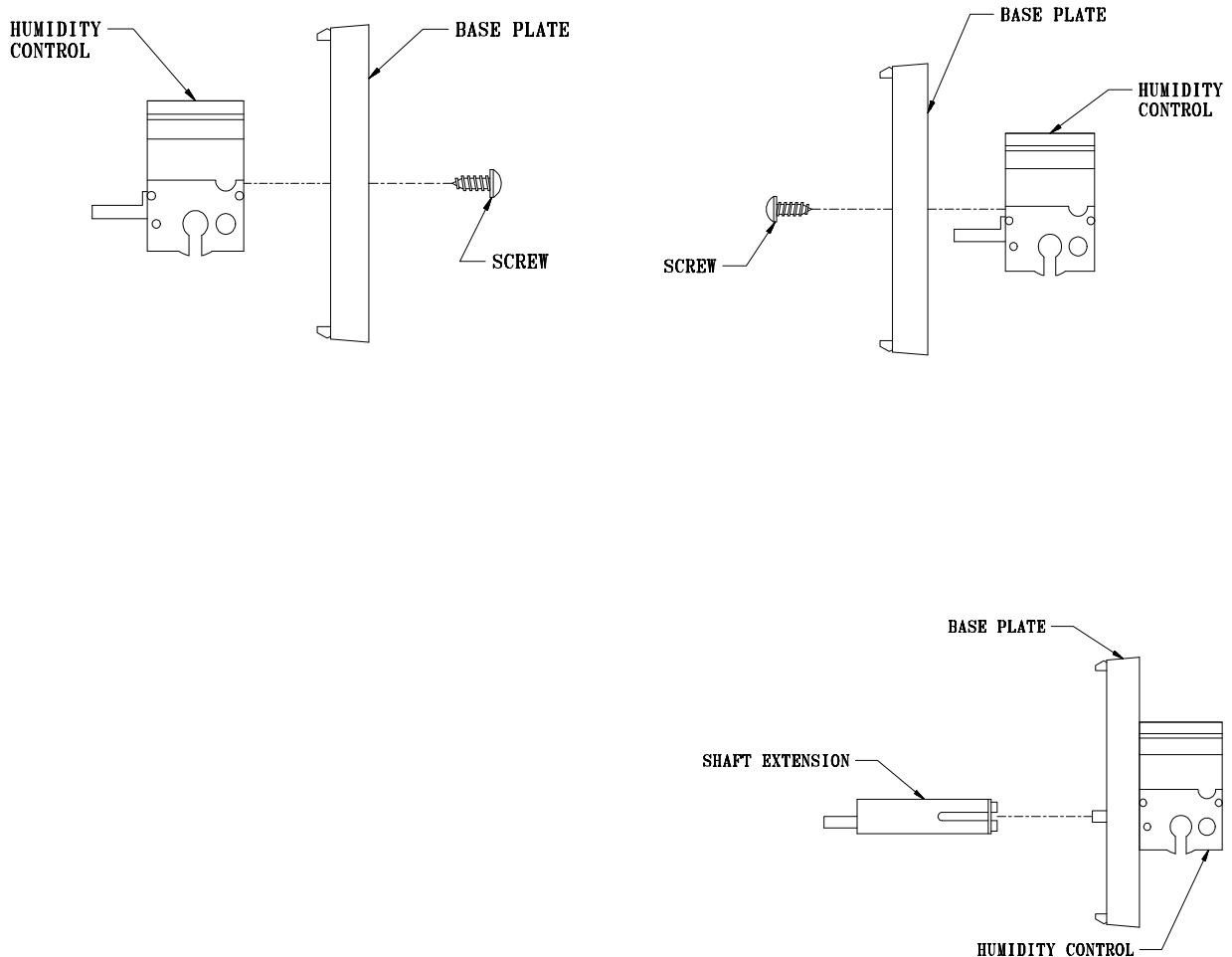

2. Attach Shaft Extension to Humidity Control Adjustment Knob. (Fig. 3)
 3. Place Mounting Template on a smooth, vertical surface of the furnace return air plenum. This location should be close enough to the TM-90R/TM-2000 housing that the 10' length of
 4. Cut away the plastic material which partially covers the wiring slot on the base plate. (Fig. 5)
- protrude through the hole in the Base Plate. (Figs. 1 & 2)
2-conductor thermostat wire can be connected to each device and secured along the length. Follow all Template Instructions. (Fig. 4)

5. Refer to the Wiring Diagram and attach the wires to the Humidity Control terminals #2 and #3, both Transformer terminals and both TM-90R/TM-2000 terminals, as indicated. The Wiring Diagram shows the proper wire termination required for each connection.

CAUTION: All wiring should conform to The National Electrical Code, NEC, and any applicable local codes.

FIG. A

EXISTING TM-90R/TM-2000 WIRING

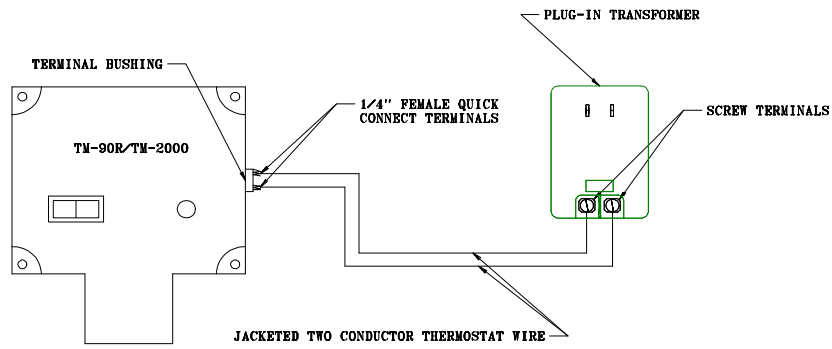

1. UNPLUG TRANSFORMER AND DISCONNECT BOTH CONDUCTORS FROM THE SCREW TERMINALS.
2. REMOVE BOTH CONDUCTORS FROM TM-90R/TM-2000 TERMINAL BUSHING. CUT OFF ONE QUICK CONNECT TERMINAL AND STRIP APPROXIMATELY 3/8" OF THE INSULATION.
3. STRIP APPROXIMATELY 3/8" OF THE INSULATION FROM ALL FOUR ENDS OF THE NEW THERMOSTAT WIRE IN THIS KIT.
4. CRIMP THE THREE QUICK CONNECT TERMINALS ONTO THE NEW THERMOSTAT WIRE IN THIS KIT AS SHOWN. (FIG. B)
5. ATTACH THE WIRES TO THE TERMINALS AND CONNECT THE BUTT SPLICE AS SHOWN. (FIG. C)

FIG. B

NEW JACKETED TWO CONDUCTOR THERMOSTAT WIRE WITH THREE QUICK CONNECT TERMINALS ATTACHED

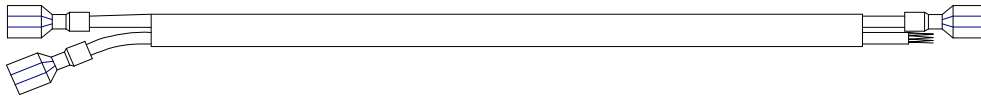
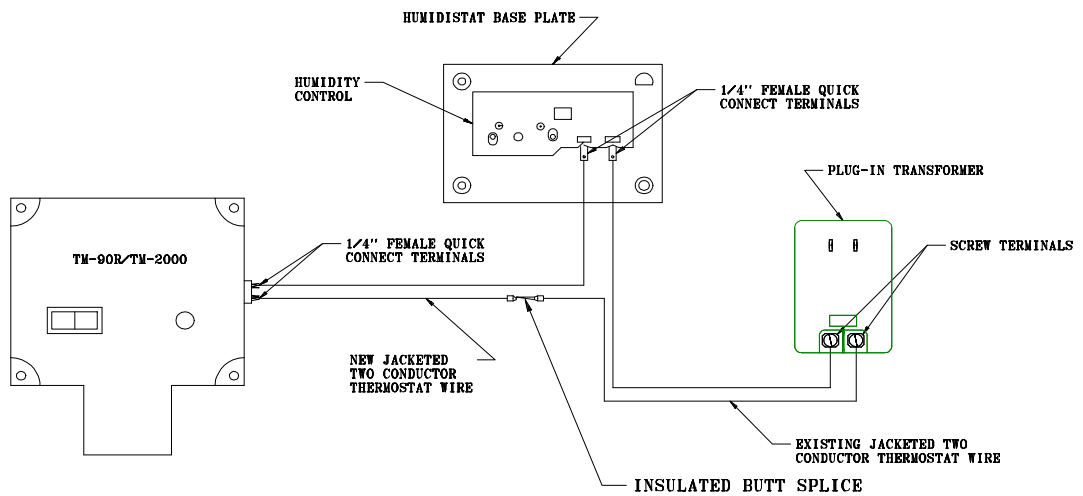
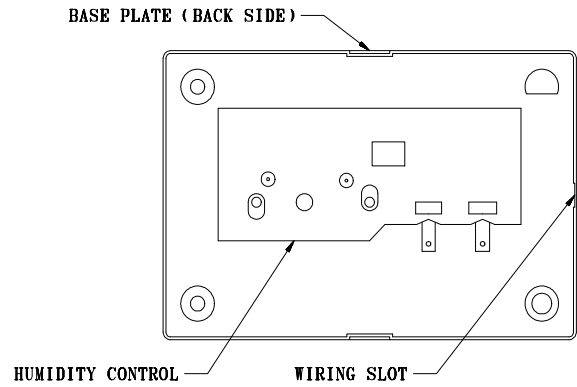
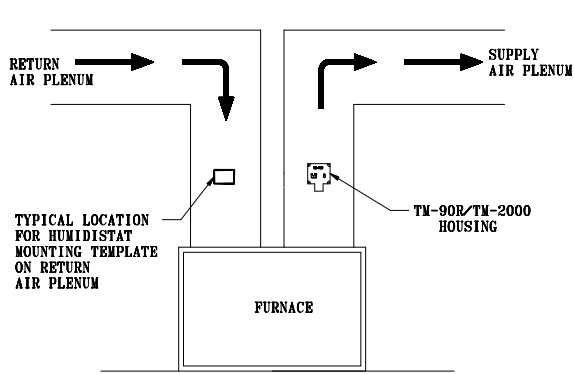

FIG. C

NEW WIRING WITH HUMIDISTAT





6. Attach the Foam Mounting Gasket to the Return Air Plenum around the opening which was previously cut. Secure the Base Plate to the furnace plenum using the two screws supplied. Be sure that the wires are placed through the wiring slot. Do not pull the wires tight. (Figs. 6 & 7)
7. Attach the Cover to the Humidistat into the receptacle. Base Plate, then attach the

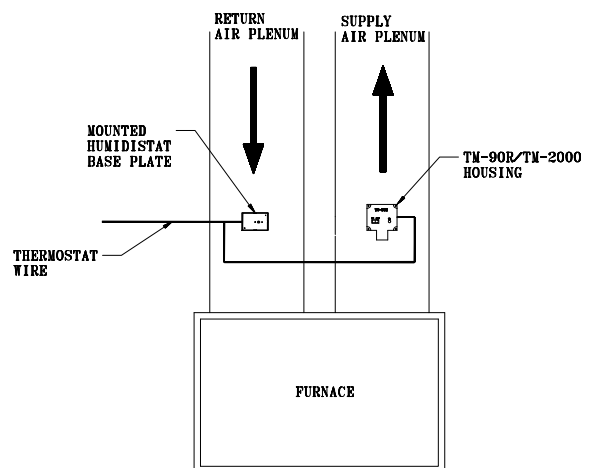
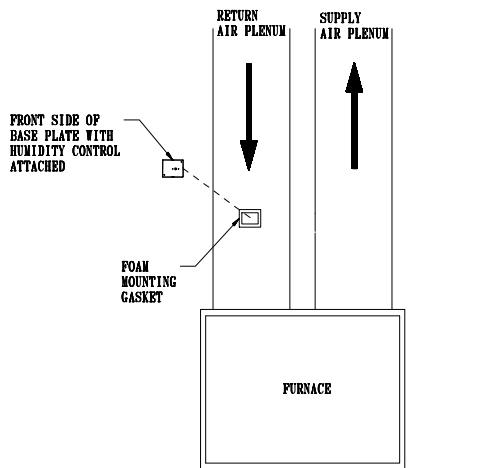

Adjustment Knob to the Knob Extension. (Fig. 8)

8. Set the Adjustment Knob to the desired humidity level.

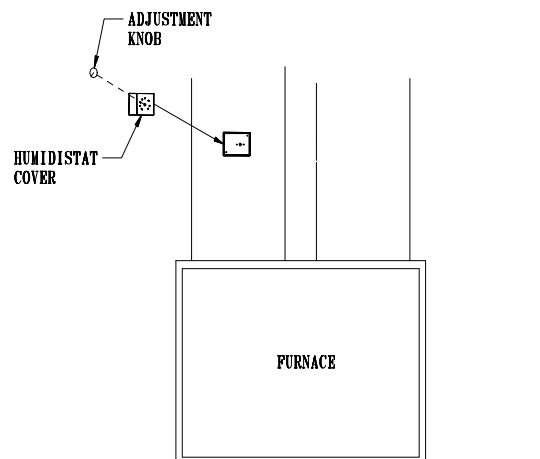

9. Switch "ON" the electrical supply to the furnace and plug the TM-90R/TM-2000 Transformer

NOTE: The Humidistat will allow the electrical current supplied by the Transformer to flow to the TM-90R/TM-2000 when there the return air plenum humidity drops below the Humidity setting. The TM-90R/TM-2000 "ON/OFF" action is still controlled by the thermal switch which senses warm air flow. The TM-90R/TM-2000 will operate only when the furnace is operating AND the Humidistat senses a need for humidity. This will prevent the TM-90R/TM-2000 from operating if there is sufficient humidity in the air and also allow greater humidity control during weather variation.

NOTE: The Humidity level indications on the Humidistat Cover are for reference only. It may be necessary to adjust the Knob to a higher or lower setting based upon the actual humidity level within the home.

ITEMS INCLUDED IN THIS KIT

HUMIDISTAT KIT: 1. (1) BOXED HUMIDISTAT
2. (1) 10' TWO CONDUCTOR THERMOSTAT WIRE
3. (1) BUTT SPLICE CONNECTOR
4. (3) 1/4" INSULATED FEMALE DISCONNECT TERMINALS
5. (1) INSTRUCTION SHEET

BOXED HUMIDISTAT: 1. (1) MOUNTING TEMPLATE
2. (1) INSTRUCTION SHEET
3. (1) MOUNTING GASKET
4. (1) KNOB EXTENSION
5. (2) SCREW ANCHOR
6. (2) MOUNTING SCREW
7. (2) TERMINAL ADAPTER
8. (2) TERMINAL SCREW
9. (1) ADJUSTMENT KNOB
10. (1) HUMIDISTAT MOUNTED ON BASE PLATE
11. (1) HUMIDISTAT COVER



THE FIELD CONTROLS COMPANY

2308 AIRPORT ROAD KINSTON, NC 28501 (919) 522-3031

P/N 46259500