

READ AND SAVE THESE INSTRUCTIONS

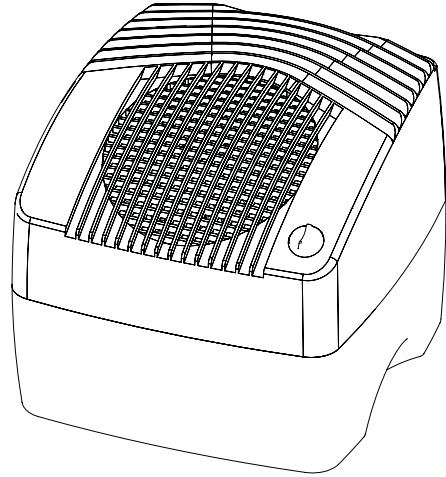

**EVAPORATIVE
TABLETOP
HUMIDIFIER**

OWNERS CARE & USE MANUAL



MODEL:

E27 000 – European Styling

- 2-speed Fan
- Portable for Versatility
- Ideal for Home, Office, Dorms, or Vacation Spots
- Easy to Clean
- Bucket Fill Design
- Removable Dishwasher Safe Base
- Safety
- Assembly
- Operation
- Care
- Parts
- Español, p.11
- Françias, p.17



**SAVE THE ENVIRONMENT
RECYCLE APPROPRIATE MATERIALS**
Patents: 5,037,583; 5,110,511; 5,133,904
Other Patents Pending



To order parts and accessories call **1-800-547-3888**

Part No. 1B71893

4/09

Printed in China

General Safety Instructions

READ BEFORE USING YOUR HUMIDIFIER

DANGER: means if the safety information is not followed someone will be seriously injured or killed.

WARNING: means if the safety information is not followed someone could be seriously injured or killed.

CAUTION: means if the safety information is not followed someone may be injured.

1. To reduce the risk of fire or shock hazard, this humidifier has a polarized plug (one blade is wider than the other.) Plug humidifier directly into a 120V, A.C. electrical outlet. Do not use extension cords. If the plug does not fully fit into the outlet, reverse plug. If it still does not fit, contact a qualified electrician to install the proper outlet. Do not change the plug in any way.
2. Keep the electric cord out of traffic areas. To reduce the risk of fire hazard, never put the electric cord under rugs, near heat registers, radiators, stoves or heaters.
3. Always unplug the unit before moving, cleaning or removing the fan assembly section from the humidifier, or whenever it is not in service.
4. Keep the humidifier clean.
5. Do not put foreign objects inside the humidifier.
6. Do not allow unit to be used as a toy. Close attention is necessary when used by or near children.
7. Never use your humidifier while any part is missing or damaged in any manner.
8. To reduce the risk of electrical hazard or damage to humidifier, do not tilt, jolt or tip humidifier while unit is running.
9. To reduce the risk of damage to humidifier, unplug when not in use.
10. To reduce the risk of accidental electrical shock, do not touch the cord or controls with wet hands.
11. To reduce the risk of fire, do not use near an open flame such as a candle or other flame source.
12. Note the warning label shown below.

WARNING: To reduce risk of fire, electric shock, or injury always unplug before servicing or cleaning.

Know Your Humidifier

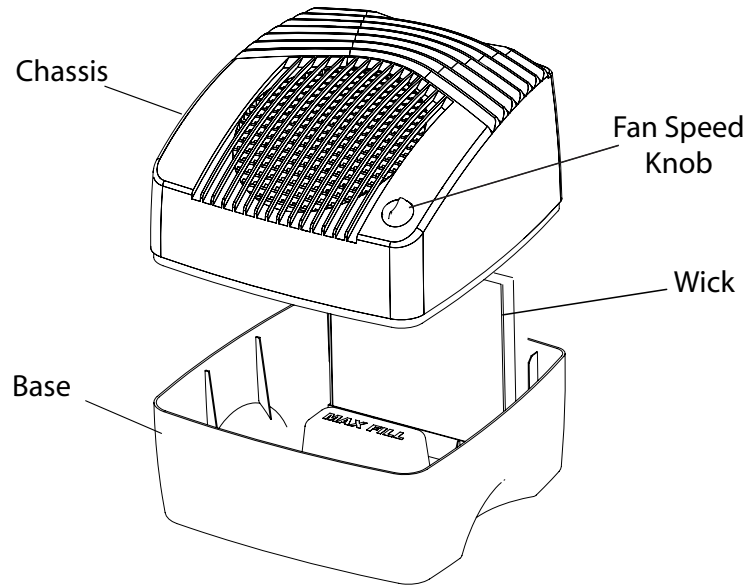

Description	E27 000
*Output per 24 hrs	2.7 gallons
Capacity of Unit	2 gallons
Sq. ft. coverage	640
Fan Speeds	2
Replacement Wick	1044 or 1040†
Controls	Analog
ETL Listed	Yes
Volts	120
Hertz	60
Watts	60

* Based on an area with average insulation and an 8' ceiling height.

Replacement Parts Available For Purchase	
Description	Part Number
Chassis (Entire top portion of unit)	1B71889
Base	1B71891
Knob	1B71892
Wick	1044 or 1040†

† We recommend using the higher performance 1040 wick as replacement.

Parts and accessories may be ordered by calling **1-800-547-3888**. Please have model number of humidifier available when calling.

How Your Humidifier Works

Your new Essick Air® Evaporative humidifier is designed to satisfy home humidity requirements through the principle of evaporation of water in the air.

Once the wick becomes saturated, air is drawn in, passes through the wick and moisture is absorbed into the air. All evaporation occurs in the humidifier so any residue remains in the wick. This natural process of evaporation creates no white dust like some other humidifiers.

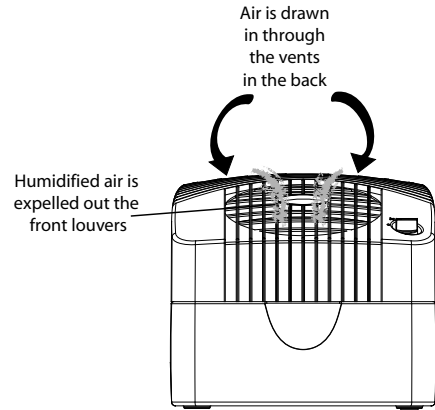

Set Up and Location

- 1) Unpack humidifier from carton and remove all packaging material, wick, etc. from box.
- 2) Place humidifier on a flat level surface. Position the humidifier where the most humidity is needed or where the most air will be circulated throughout the house such as near a cold air return. If the unit is positioned close to a window, condensation may form on the window pane. If this occurs the unit should be repositioned in another location.

For Reference Only

When Outdoor Temperature is:		Recommended Indoor Relative Humidity (RH) is
F	C	
-10°	-24°	20%
2°	-18°	25%
10°	-12°	30%
20°*	-6°*	35%

* or higher

CAUTION: Do NOT position the unit directly in front of a hot air duct or radiator. Do NOT place on soft carpet. We suggest placing the unit on a table or on a bookshelf.

NOTE: Due to release of cool, moist air from humidifier, it is best to direct air away from thermostat and hot air registers, and to position humidifier next to an inside wall. Unit should not be placed where cold air from outside walls or warm air from a hot air register blows directly on it.

- 3) Place the humidifier at least 4 inches from the wall.

Filling

CAUTION: Disconnect power before filling, cleaning or servicing unit. Keep grille dry at all times.

- 1) Lift chassis (top section) off base. Position wick in the notch at the back of the base.

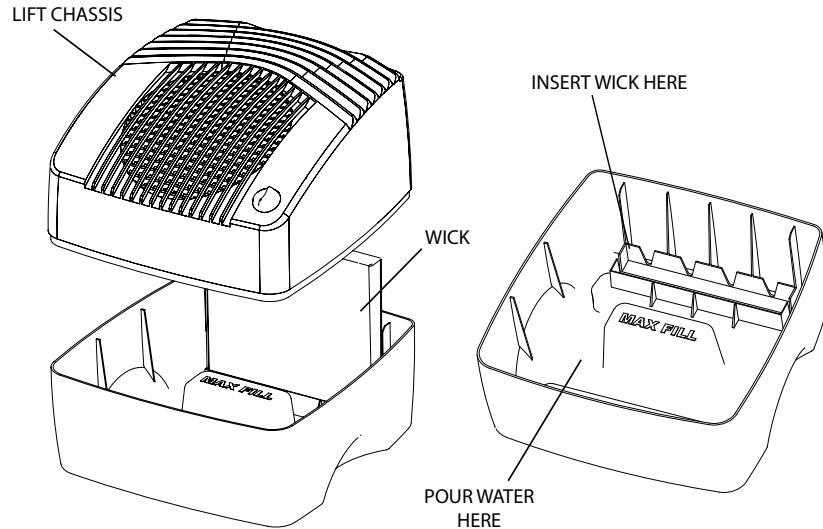

- 2) Before replacing the chassis, fill the base with unsoftened water. **DO NOT POUR WATER OVER THE ELECTRICAL CHASSIS.** Fill the base only through the opening provided (See illustration), to the level marked "MAX FILL" on the center bottom of the base. **If water spills on the chassis, it must be allowed to dry completely before turning on the humidifier.** If you have only softened water available in your home, you can use it, but you will notice a build up of minerals on the evaporative wicks much sooner. Base capacity is 2.0 gallons. **DO NOT OVERFILL.**

CAUTION: Do not spill water on fan motor. Electrical components must be kept dry.

- 3) We recommend using only EPA registered bacteriostat treatment such as Essick Air Bacteriostat, Part Number 1970 whenever you refill the humidifier base to eliminate bacterial growth. Add bacteriostat according to the instructions on the bottle.
- 4) Reposition the chassis on the base and the unit is ready for operation.
- 5) Plug cord into wall receptacle.

Controls and Operation

NOTE: The humidifier should be placed at least FOUR inches away from any walls and away from heat registers. Do not place on soft carpet. Unrestricted airflow into the unit will result in the best efficiency and performance.

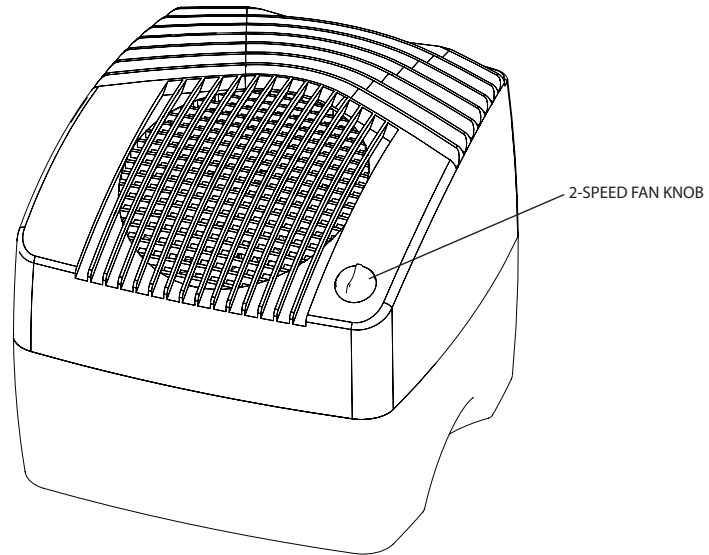

1) This unit has two fan speeds controlled by the lower right hand knob.

NOTE: If excessive condensation occurs, reduce fan to a lower speed setting.

Care and Maintenance

Cleaning your humidifier regularly helps eliminate odors, bacterial and fungal growth. Ordinary household bleach is a good disinfectant and can be used to wipe out the humidifier base after cleaning.

We recommend cleaning your humidifier at least once a week to maintain optimum environmental conditions from your humidifier.

We also recommend using Essick Air Bacteriostat Treatment each time you refill your humidifier to eliminate bacterial growth. Add bacteriostat according to the instructions on the bottle. Please call 1-800-547-3888 to order Bacteriostat Treatment reference part number 1970.

Cleaning Instructions

- 1) Turn unit off at switch then unplug electrical cord from the wall outlet.
- 2) Lift off chassis from base and set aside. Carry base to cleaning basin/sink.
- 3) Lift wick from base, allow water to drain from wick into base and then set aside.
- 4) Empty base into sink. Remove any remaining water from base with a sponge.
- 5) Fill base to "MAX FILL" line with water and then add 8oz. (1cup) of white vinegar. Let solution stay 20 minutes, then empty.
- 6) Clean all interior surfaces of base with a soft brush. Dampen soft cloth with white vinegar and wipe out base to remove scale.
- 7) Rinse base thoroughly with fresh water and remove scale and cleaning solution.

Disinfecting Base

- 8) Fill base with water to "MAX FILL" line and add 3 teaspoons of chlorine bleach. Let solution stand for 20 minutes.
- 9) Empty and rinse thoroughly. Refill base with water and reassemble unit.

Summer Storage

- 1) Clean unit as outlined in Care & Maintenance section.
- 2) Discard used wicks and any water in the base and allow unit to dry thoroughly before storage. **Do not** store with water inside unit.
- 3) Do not store unit in an attic or other high-temperature area.
- 4) Install new wick at beginning of season.

**ESSICK AIR PRODUCTS
HUMIDIFIER WARRANTY POLICY**

**EFFECTIVE APRIL 1, 2008
SALES RECEIPT REQUIRED AS PROOF OF PURCHASE
FOR ALL WARRANTY CLAIMS.**

This product is warranted against defects in workmanship and materials for one year from the date of sale except for motors, which are warranted for two years. This warranty does not apply to filters or wicks which are customer replaceable parts.

This warranty applies only to the original purchaser of the product when it is purchased from a reputable retailer/dealer.

This warranty does not apply to damage from accident, misuse, alterations, unauthorized repairs, unauthorized use, mishandling, unreasonable use, abuse, including failure to perform reasonable maintenance, normal wear and tear, nor where the connected voltage is more than 5% above the nameplate voltage, nor to the equipment or products being improperly installed or wired or maintained in violation of this Owner's Manual.

Alterations include the substitution of name brand components including, but not limited to wicks and bacteria treatment.

THIS PRODUCT IS NOT INTENDED FOR COMMERCIAL USE. THIS IS THE SOLE AND EXCLUSIVE WARRANTY GIVEN BY MANUFACTURER WITH RESPECT TO THE PRODUCTS AND, TO THE MAXIMUM EXTENT PERMITTED BY LAW, IS IN LIEU OF AND EXCLUDES ALL OTHER WARRANTIES AND CONDITIONS, EXPRESS OR IMPLIED, ARISING BY OPERATION OF LAW OR OTHERWISE. INCLUDING WITHOUT LIMITATION, MERCHANTABILITY AND/OR FITNESS FOR A PARTICULAR PURPOSE.

No employee, agent, dealer or other person is authorized to give any warranties or conditions on behalf of the manufacturer. The customer shall be responsible for all costs incurred in the removal or reinstallation and shipping of the product for repairs.

Within the limitations of this warranty, purchaser with inoperative units should contact customer service @ 800-547-3888 for paperwork and instructions on the return of the unit for repair. A copy of the sales receipt is required before authorization to return a unit for repair is approved. The manufacturer will repair or replace the product, at its discretion, with return freight paid by the manufacturer. It is agreed that such repair or replacement is the exclusive remedy available from the manufacturer and that TO THE MAXIMUM EXTENT PERMITTED BY LAW, THE MANUFACTURER IS NOT RESPONSIBLE FOR DAMAGES OF ANY KIND, INCLUDING INCIDENTAL AND CONSEQUENTIAL DAMAGE OR LOSS OF PROFITS OR REVENUES.

This warranty will be null & void if purchaser attempts to repair or replace any parts which are mechanical or electrical.

The warranty gives the customer specific legal rights, and the customer may also have other rights which vary from province to province, or state to state.