

This Owner's Manual is provided and hosted by [Appliance Factory Parts](#).

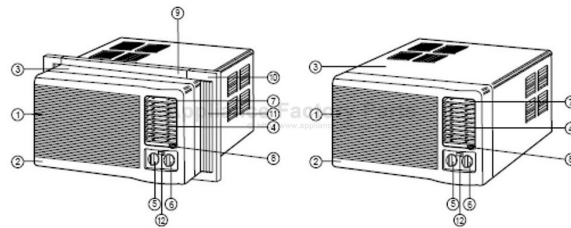

Daewoo DWA-150CS Owner's Manual

[Shop genuine replacement parts for Daewoo
DWA-150CS](#)



[Find Your Daewoo Air Conditioner Parts - Select From 15 Models](#)

----- Manual continues below -----

TABLE OF CONTENTS

1. PRECAUTION.....	2
2. GENERAL SPECIFICATIONS	3
3. NAMES OF MAJOR COMPONENTS	4
4. FUNCTION OF MAIN COMPONENTS	5
5. GENERAL INFORMATIONS	6
6. CARE AND MAINTENANCE	7
7. TROUBLE SHOOTING GUIDE	8
8. HOW TO DISASSEMBLE	10
9. WIRING DIAGRAM	11
10. REFRIGERANT CYCLE	12
11. EXPLODED DIAGRAM AND PARTS LIST	13

1. PRECAUTION

Please observe the following instructions.

1. Turn off unit.

Make sure the unit is OFF and the AC cord is unplugged before repairing or servicing.

2. In case of checking the circuit unavoidably while the unit is connected with power source, be careful not to connect with the part of electric charge.

You may cause electric shock.

3. Use of proper part if you need to replace the part, be sure to use genuine part of servicing model.

Do not repair or replace the electric contact part.

Consumer must not repair the unit, because it is dangerous.

4. Use of proper tool.

You must use the proper tool to repair the unit, and use the measuring appliance adjusted accurately.

5. Damage of electric wire and power cord when servicing.

Check electric wire and a surely replace a damage electric wire and a damage power cord.

6. Never use connecting the middle of wire, after cutting the middle of wire.

It may cause a fire and trouble.

7. Checking the insulation resistance.

After you complete the assembly of unit, surely check the insulation resistance.

Confirm that the insulation resistance of the power line and the ground terminal is over 30M Ω by measuring insulation resistance.

8. Checking the ground.

After checking the ground, servicing it completely.

9. Checking the installation.

After checking the installation, servicing it completely.

10. Care children.

When servicing, do not make the children approach the air-conditioner.

2. GENERAL SPECIFICATIONS

ITEM		MODEL	DWC-121C/CS	DWA-150C/CS
Function			Cooling only	
Power source			AC 115V, 60Hz Single Phase	AC 220V, 60Hz Single Phase
Cooling Capacity	Btu/h		12,100 Btu/h	14,300 Btu/h
	Kcal/h		3,050 Kcal/h	3,604 Kcal/h
Energy Efficiency Ratio	Btu/wh		10.1 Btu/wh	9.8 Btu/wh
	Kcal/wh		2.55 Kcal/wh	2.47 Kcal/wh
Dehumidification	Pts/h		2.36 Pts/h	3.04 Pts/h
Electrical Data	Power Input		1,172 W	1,460 W
	Running Current		11A	6.6A
Compressor	Type		Rotary	
	Model		QK164CN12	QJ196KC23
	Capacitor		40 μ F-370VAC	25 μ F-370VAC
Motor	Model		AM12DIOD10	AM12 DIOD11
	Capacitor		12 μ F-370VAC	4 μ F-370VAC
	Indoor-Fan		Blower-Fan	
	Outdoor-Fan		Propeller-Fan	
Dimensions	Unit(W x H x D)		23.6(W) x 14.9(H) x 21.0(D) Inch (600(W) x 380(H) x 535(D) mm)	
	PACKING(W x H x D)		26.1(W) x 18.1(H) x 22.6(D) inch (663(W) x 460(H) x 573(D) mm)	
Weight	Net Weight		88 lbs (38.8Kg)	92 lbs (42Kg)
	Gross Weight		89 lbs (40.3 Kg)	96 lbs (43.5Kg)

3.NAMES OF MAJOR COMPONENTS

• DWC-121C / DWA-150C

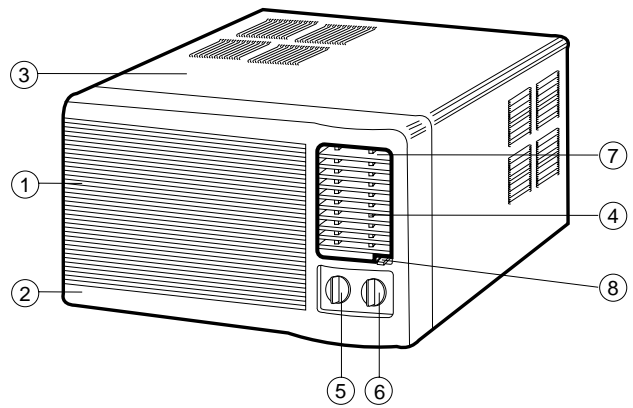
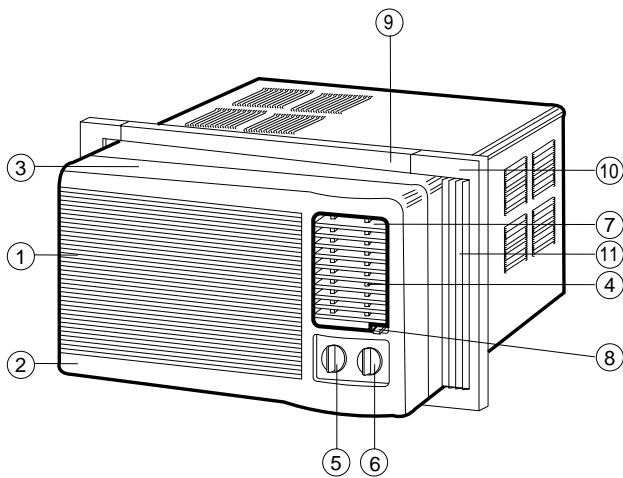

• DWC-121CS / DWA-150CS

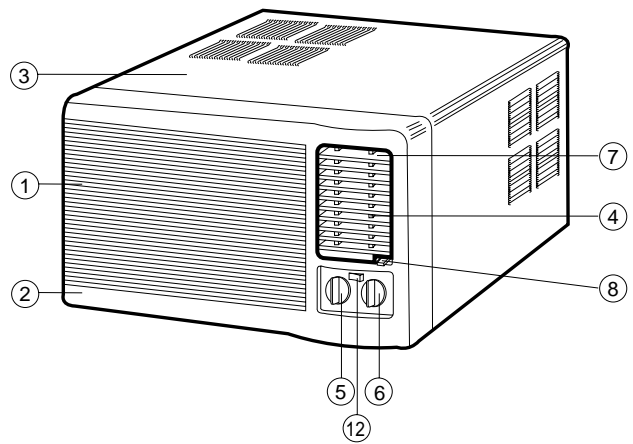
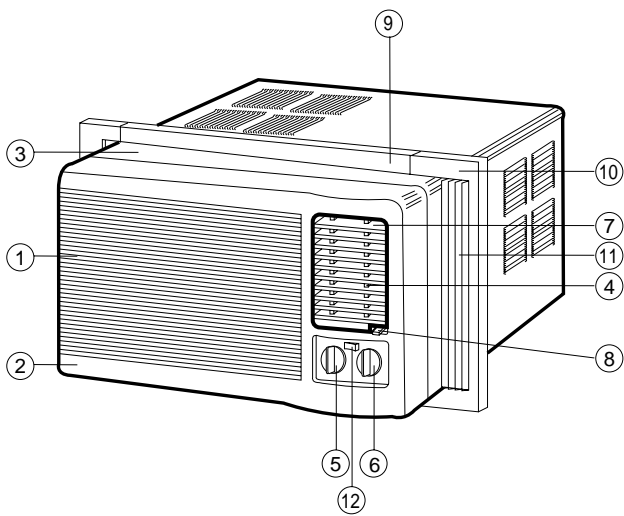

NO	PART NAME	NO	PART NAME
1	AIR FILTER	7	BLADE HORIZONTAL
2	GRILL FRONT	8	AIR VENT
3	CABINET	9	PLATE WINDOW TOP
4	BLADE VERTICAL	10	FRAME WINDOW KIT
5	KNOB THERMOSTAT	11	SHUTTER WINDOW
6	KNOB SELECTOR	12	AUTO LOUVER SW (DWC-121CS/DWA-150CS)

4. FUNCTION OF MAIN COMPONENTS

1. ROTARY SWITCH (SELECTOR)

Please refer to the part of selector in the chapter 9 (Wiring Diagram).

The rotary switch (selector) controls the fan motor's rotation speed, and has six positions.

The function of the six position is as follow.

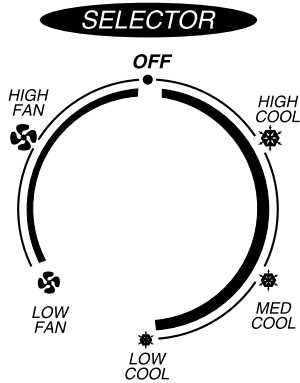

- OFF: This position stops all operations of the air conditioner.
- HIGH COOL: This position provides the maximum air flow for rapid cooling, dehumidifying and dust removing operations. (Use this position on sultry summer days.)
- MED COOL: This position provide the edium air flow for cooling dehumidifying and dust removing operations
- LOW COOL: This position provides the minimum air flow for quiet cooling, dehumidifying operations. (Use this position on suitable for night-time.)
- HIGH FAN: This position provides the maximum air flow alone fan operation without cooling operation.
- LOW FAN: This position provides the minimum air flow air flow alone fan operation without cooling operation.

2. THERMOSTAT (TEMPERATURE CONTROL)

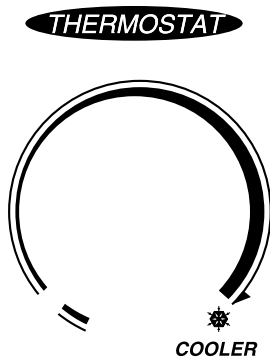

- The Thermostat automatically starts and stops operation in order to keep the room temperature at a proper level, and this results in efficient use of power and economical cooling.
- Turn clockwise for a cooler room temperature.
- Turn counter-clockwise for a warmer room temperature.

3. MOTOR

The motor is used to rotate the indoor and outdoor fan so that the room air can be recirculated.

4. FAN

- BLOWR FAN: The Blower draws hot air from the room through the Evaporator and then discharges it back into the cool air. It circulates the room air.
- PROPELLER FAN: The propeller draws outdoor air through louvering and cools Condenser, and then blows the hot air out.

5. CAPACITOR

The Capacitor enlarges the difference of phase between main coil and sub coil so that the Compressor and Fan Motor starts well.

6. ACCUMULATOR

The Accumulator blocks the unflow of liquid refrigerant and impurities into the Compressor.

5. GENERAL INFORMATIONS

1. CHANGING AIR FLOW DIRECTION

Air flow deflectors divert air from center flow to left or right.
Adjust deflectors for desired air flow pattern.

2. AIR FLOW AROUND UNIT

Check in door grill and outdoor louvers for air flow obstructions. Do not block air flow to and from unit. The outdoor coil should be checked and periodically cleaned for debris that may collect and block unit air flow. If air flow is obstructed or deflected back into unit, the compressor may cycle on and off rapidly, causing early compressor failure.

3. Electrical Grounding Instructions.

This appliance is equipped with a three-prong(grounding) plug for protection against possible shock hazards. If a two-prong wall receptacle is encountered, the customer is required to contact a qualified electrician and have the two-prong wall receptacle replaced with a properly grounded three-prong wall receptacle in accordance with the National Electrical Code.

4. USE OF EXTENSION CORDS

Because of potential safety hazards under certain conditions we strongly recommend against the use of an extension cord. However, if you still elect to use an extension cord, it is absolutely necessary that it be a UL listed 3-wire grounding type appliance extension cord rated has a 3-blade grounding plug and a 3-slot receptacle that will plug into appliance. The marked rating of the extension cord should be 115V 13A, 220V 10A or more.

5. DRAIN HOLE AND WATER DRIPPING OUTSIDE

Locate drain hole at the rear of unit. Water in base pan is picked up by the fan blade and thrown onto the warm outdoor coil where it evaporates. The air conditioner must be installed level or tilted or slightly to the outside for proper water disposal. On exceptionally hot and humid days the air conditioner may permit excess water to pass thru rear drain hole or overflow. This should be considered normal.

6. CARE AND MAINTENANCE

1. AIR FILTER

Clean the air filter, which removes dust inside the room.

It should be washed at least once every week during operation.

1. Remove the Air Filter from the front grill by pulling up.
2. Clean Air Filter with a vacuum cleaner or lukewarm, soapy water.
3. Shake it when clean to remove moisture completely. Replace it.

2. CLEANING THE AIR CONDITIONER

1. At least once a year, remove cabinet and thoroughly clean air conditioner. Have the unit inspected by an authorized servicer to ensure unit is functioning properly.
2. Wash air conditioner with lukewarm, soapy water as needed. Rinse and dry thoroughly.
3. If using concentrated liquid detergent, dilute in warm water first.
4. Front grill may be wiped off with a cloth dampened in a mild detergent solution.
5. Cabinet may be washed with mild soap or detergent and lukewarm water, then polished with liquid wax for appliances.
6. Condenser and Evaporator coils should be cleaned at the beginning of each cooling season. Use a soft brush or vacuum cleaner to clean them, making sure that the Condenser and Evaporator coils are not damaged.
7. Do not use abrasive cleaners. These items scratch, crack and discolor surfaces.

7. TROUBLE SHOOTING GUIDE

TROUBLE	SITUATION	ANALYSIS	CAUSE	REMEDY
Fan motor and compressor do not run	1. Power failure	1) Power plug 2) Circuit breaker	1) Power failure 2) Circuit breaker is tripped 3) Power plug is not contacting	<ul style="list-style-type: none"> ● Consult your electric company ● In case of a breaker, turn it on and off a few times ● Replace the power plug
	2. Power is supplied, but the equipment does not run	1) receptacle 2) Operation switch 3) Cord or lead wire to the switch	<ul style="list-style-type: none"> ● Disconnection ● Mechanical failure of switch 1) Disconnection 2) Malfunction of contact	<ul style="list-style-type: none"> ● Repair or replace the receptacle ● Replace the cord or lead wire
Switch is in "cool" position but the compressor does not run	1. Not operating at all	1) Compressor 2) Thermostat	<ul style="list-style-type: none"> ● Disconnection or burned-out 1) Failure 2) Malfunction 3) Knob is not set to the proper setting	<ul style="list-style-type: none"> ● Replace the compressor or connection wire ● Replace ● Repair or replace ● Turn knob for cooler setting
		3) Selector switch 4) O.L.P 5) Capacitor	<ul style="list-style-type: none"> ● Failure of malfunction of proper setting 1) Disconnection 2) Malfunction of contact <ul style="list-style-type: none"> ● Lack of capacity ● Disconnection 	<ul style="list-style-type: none"> ● Repair or replace the swtting ● Repair ● Repair or replace ● Replace ● Repair
	2. Compressor	1) Electricity 2) Room temperature and outside temperature 3) Compressor 4) O.L.P 5) Capacitor	1) The voltage exceeded allowed range 2) Capacity of wire is not sufficient <ul style="list-style-type: none"> ● Extremely high ● Burned-out ● Malfunction ● Lack of capacity 	<ul style="list-style-type: none"> ● Consult your electric company ● Check the capacity of wire ● Ventilate well and remove the heat source ● Replace ● Replace ● Replace
3. Frequent start and stop	1) Thermostat 2) Capacitor 3) O.L.P	1) Thermostat	● Malfunction	● Replace
		2) Capacitor	● Lack of capacity	● Replace
		3) O.L.P	● Malfunction	● Replace

TROUBLE	SITUATION	ANALYSIS	CAUSE	REMEDY
The compressor runs but the motor doesn't run		<ol style="list-style-type: none"> 1) Fan 2) Fan motor 3) Capacitor 4) Fan motor circuit 	<ul style="list-style-type: none"> ● Blocked by others ● Disconnection or burned-out electric cord ● Failure malfunction of contact ● Disconnection of malfunction of contact 	<ul style="list-style-type: none"> ● Repair ● Replace the fan motor ● Replace ● Check the circuit
Both fan motor and compressor are running but cooling is bad	Not cooling at all	Refrigerant system	<ol style="list-style-type: none"> 1) Refrigerant system is choked 2) Compressor failure 3) Leakage of refrigerant gas 	<ul style="list-style-type: none"> ● Repair ● Repair ● Recharge refrigerant gas
	Insufficient cooling	<ol style="list-style-type: none"> 1) Refrigerant system 2) Filter 3) Heat exchanger of condenser 	<ol style="list-style-type: none"> 1) Refrigerant system is choked 2) Compressor failure 3) Leakage of refrigerant gas 4) Refrigerant charge is too high <ul style="list-style-type: none"> ● Clogged up with dust <ol style="list-style-type: none"> 1) Fin is clogged up with dust 2) The ventilation is not good 3) The unit is exposed to the sunlight 4) Other heat source is added in the room 	<ul style="list-style-type: none"> ● Check and repair refrigerant system ● Replace ● Check a part of Leakage and repair ● Repair and recharge ● Clean the air filter ● Clean the unit ● Shade the unit from the sunlight ● Remove the added heat source
Vibration & Noise		<ol style="list-style-type: none"> 1) Installation place 2) Fan 3) Fixing screws 4) Electric components 	<ul style="list-style-type: none"> ● Installation of the unit is imperfectly done <ol style="list-style-type: none"> 1) Fan is contacted with obstacles 2) Fixing bolt <ul style="list-style-type: none"> ● Have a screw loose ● Electrical noise 	<ul style="list-style-type: none"> ● Install the unit perfectly ● Remove obstacles ● Tighten the bolt ● Tighten the screw ● Exchange the components
Water leakage into room		● Installation condition	● The front is lower than rear side	● Make rear side of the unit lower than the front
Electric shock (Leakage of current)		● Insulation of components	<ol style="list-style-type: none"> 1) Insulation defect of wiring and lead wire 2) Leakage of current due to the dew or rust 	<ul style="list-style-type: none"> ● Check the unit's Leakage of current. ● Replace the defective parts or components

8. HOW TO DISASSEMBLE

Please refer to the chapter 11 (Exploded diagram and parts list).

1	Before service of any part.	<ol style="list-style-type: none"> 1. Stop the unit, remove the power cord from the receptacles. 2. Move the unit to the safe location for the suitable work.
2	Ass'y Fan Motor - Fan Motor - Propeller Fan - Blower Fan	<ol style="list-style-type: none"> 1. Remove Front Grill <ul style="list-style-type: none"> - Remove Filter Pre. - Remove screw(2 point) in Front Grill. 2. Remove Cabinet from the unit. <ul style="list-style-type: none"> - Remove screws (2 point) from the unit's sides. 3. Remove Holder Screll. 4. Remove Scroll upper <ul style="list-style-type: none"> - Remove screws (3 point) from Plate Scroll's sides. 5. Remove Ass'y Control Box <ul style="list-style-type: none"> - Remove screws (4 point). - Remove wires in the each components. 6. Remove wires in the Panel Housing. 7. Remove screws (4 point) from Ass'y Fan Motor's sides. <ul style="list-style-type: none"> - Ass'y Fan Motor is assembly of Fan Motor, Propeller and Blower Fan, Orifice and Panel Housing. 8. Lift the Ass'y Fan Motor from the unit. 9. Remove clip han (2 point) from the shaft of Fan Motor. 10. Remove Propeller Fan from the shaft of Fan Motor. 11. Remove Blower Fan from the shaft of Fan Motor. 12. Remove Fan Motor from Panel Housing. <ul style="list-style-type: none"> - Remove screws (4 point).
3	Ass'y Control Box - Rotary Switch (selector) - Thermostat - Capacitor - Power Cord	<ol style="list-style-type: none"> 1. Same as the procedure 1 to 5 in the Item 2.
4	O.L.P	<ol style="list-style-type: none"> 1. Same as the procedure 1 to 2 in the Item 2. 2. Remove Terminal Cover from Compressor. <ul style="list-style-type: none"> - Remove hex-nut (1 point).

9. WIRING DIAGRAM

• DWC-121C / CS WIRING DIAGRAM

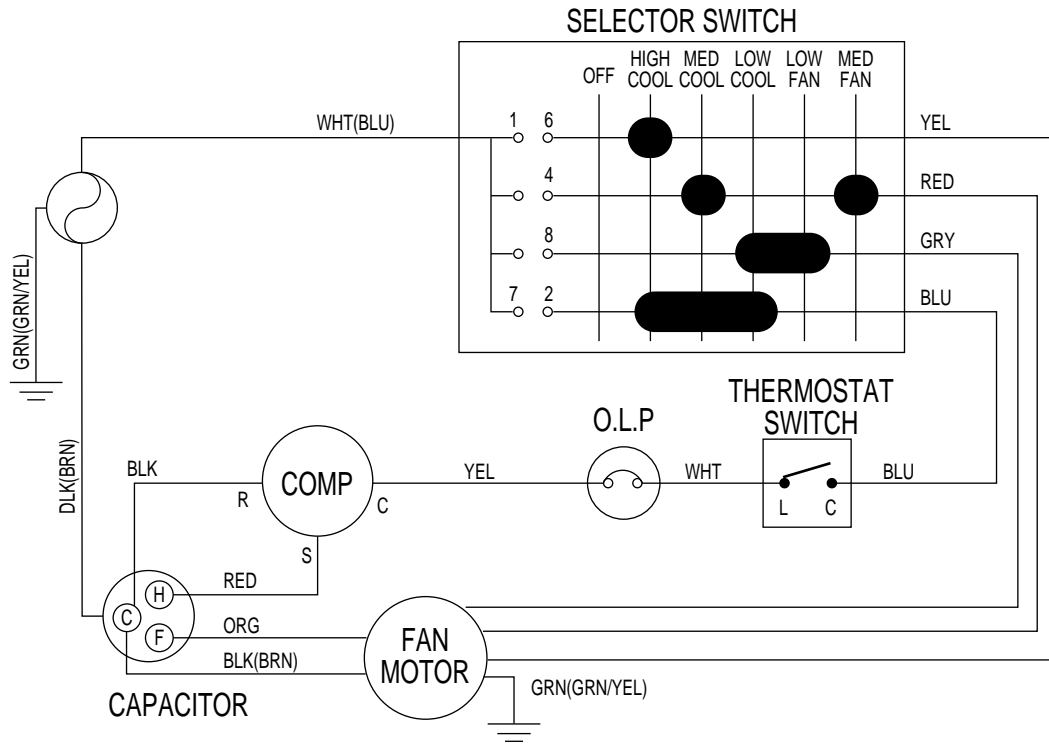

• DWC-121C / CS WIRING DIAGRAM

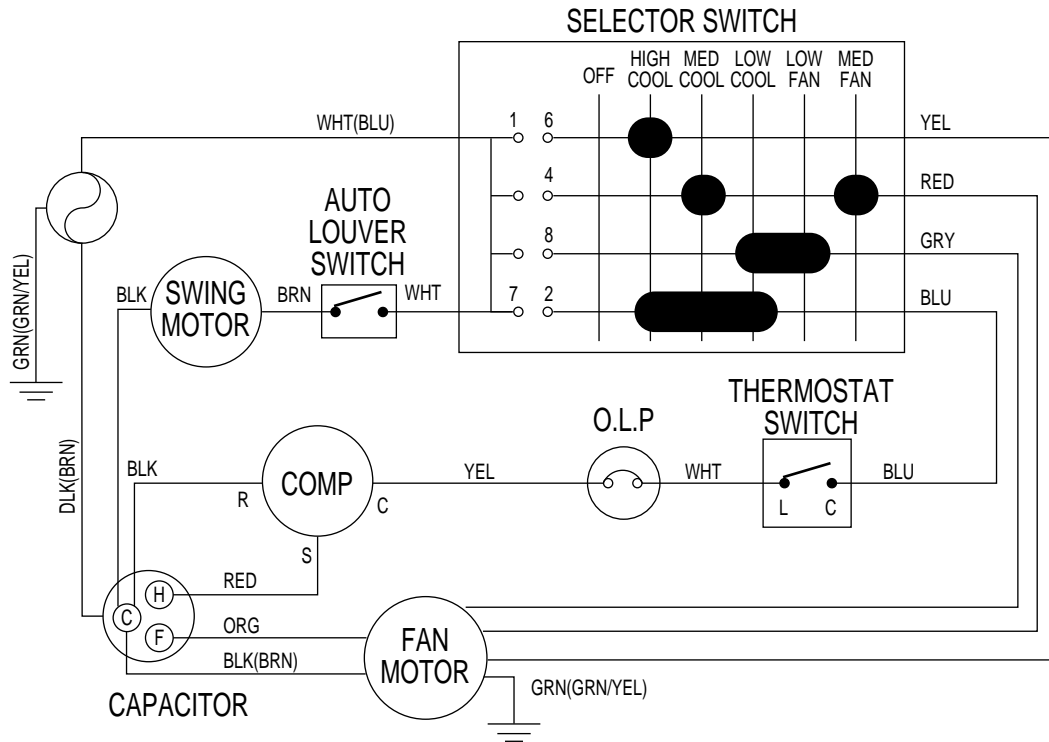

10. REFRIGERANT CYCLE

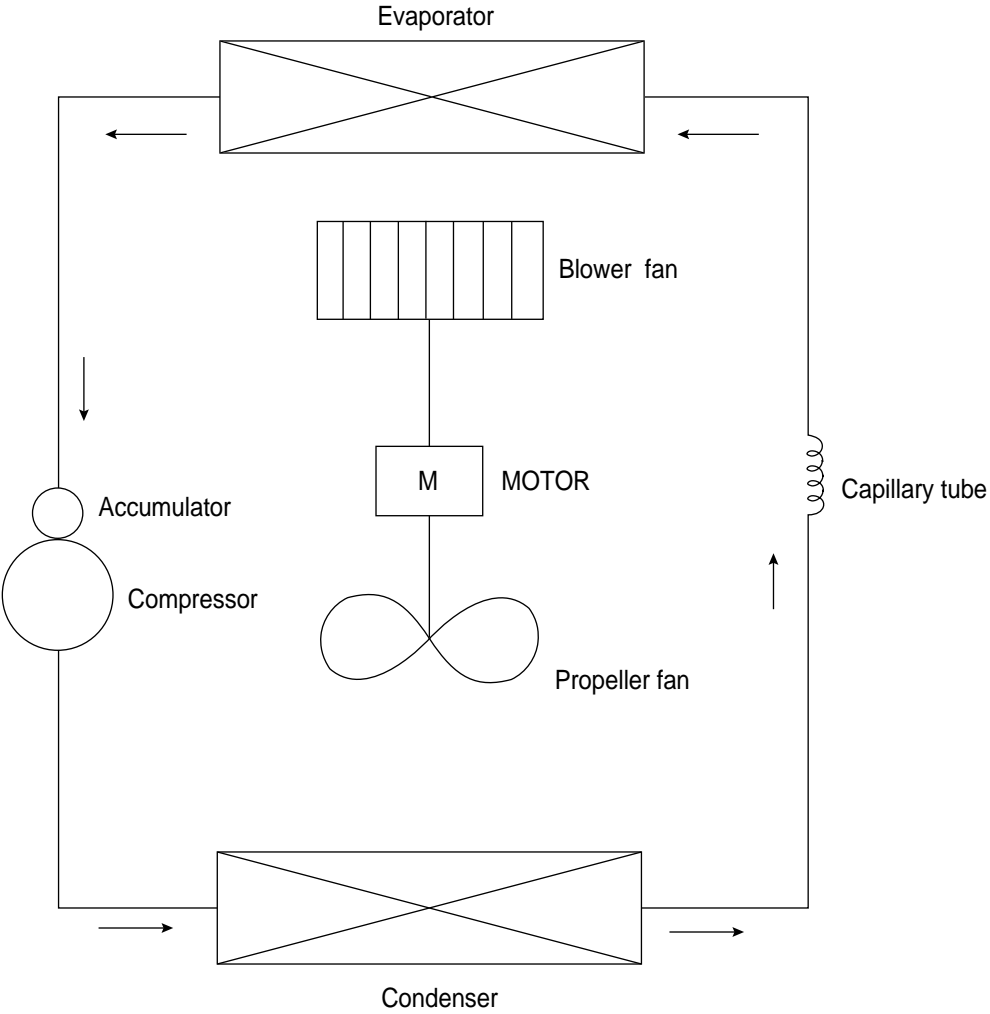

11. EXPLODED DIAGRAM AND PARTS LIST

■ DWC-121C/CS, DWA-150C/CS PART LIST

No.	CODE	COMPONENTS	Q'TY	SPECIFICATION	REMARK
1	3102402400	GRILL FRONT	1	HIPS	
2	3103400700	KNOB	2	HIPS	
3	3101600600	DECORATE FRONT	1	PC FILM	
4	3101902100	FILTER PRE	1	HIPS	
5	3106501800	BLADE VERTICAL	1	HIPS	
6	3106501700	BLADE HORIZONTAL	2	PP	
7	3108503600	SEAL GRILLE	1	F-US	
8	3108100900	PAN BASE	1	SGCC T1.0	
9	3107400800	ASS'Y EVAPORATOR	1	350X330.2(ø9.52 2R2C)	DWC-121C/CS(ONLY)
	3107400810	ASS'Y EVAPORATOR	1	350X330.2(ø7 3R4C)	DWA-150C/CS(ONLY)
10	3104421100	PIPE EVA IN	1	C1220T-O OD9.52	DWC-121C/CS(ONLY)
	3104421110	PIPE EVA IN	1	C1220T-O OD7	DWA-150C/CS(ONLY)
11	3100063600	PIPE EVA OUT AS	1	C1220T-O OD9.52	DWC-121C/CS(ONLY)
	3100063610	PIPE EVA OUT AS	1	C1220T-O OD7	DWA-150C/CS(ONLY)
12	3104421700	PIPE EVA OUT 1	1	C1220T-O OD9.52	DWC-121C/CS(ONLY)
	3104421710	PIPE EVA OUT 1	1	C1220T-O OD7	DWA-150C/CS(ONLY)
13	3104423100	PIPE SUNCTION	1	C1220T-O OD12.7	DWC-121C/CS(ONLY)
	3104423110	PIPE SUNCTION	1	C1220T-O OD12.7	DWA-150C/CS(ONLY)
14	3100061600	PIPE CAPILLARY AS	1	C1220T-O ID1.6 L800	DWC-121C/CS(ONLY)
	3100061610	PIPE CAPILLARY AS	1	C1220T-O	DWA-150C/CS(ONLY)
15	3107101190	COMP AS	1	LG-QK164CN12	DWC-121C/CS(ONLY)
	-	COMP AS	1	LG-QJ196KC23	DWA-150C/CS(ONLY)
16	3104425800	PIPE DISCHARGE	1	C1220T-O OD7.94	DWC-121C/CS(ONLY)
	3104425810	PIPE DISCHARGE	1	C1220T-O OD7.94	DWA-150C/CS(ONLY)
17	3100063500	PIPE COND OUT AS	1	C1220T-O OD7	DWC-121C/CS(ONLY)
	3100063510	PIPE COND OUT AS	1	C1220T-O OD7	DWA-150C/CS(ONLY)
18	3100063400	PIPE COND IN AS	1	C1220T-O OD7	DWC-121C/CS(ONLY)
	3100063410	PIPE COND IN AS	1	C1220T-O	DWA-150C/CS(ONLY)
19	3106800300	ASS'Y CONDESOR	1	515X341.5 (ø7 3R2C)	DWC-121C/CS(ONLY)
	3106800310	ASS'Y CONDESOR	1	515X341.5 (ø7 3R2C)	DWA-150C/CS(ONLY)
19-1	3108504300	SEAL COND TOP	1	F-US	DWC-121C/CS(ONLY)
	3108504300	SEAL COND TOP	1	F-US	DWA-150C/CS(ONLY)
20	3101202800	CLIP FAN	2	SK-5	
21	3101802600	PAN BLOWER	1	ABS	
22	3101404100	COVER MOTOR	1	EPS	
23	3104202000	PANEL HOUSING	1	SGCC T1.0	
24	3102000500	FIXTURE RUBBER	1	NBR	
24-1	3100000010	BUSHING GUIDE	1	NBR	
25	3108004900	MOTOR FAN	1	DAEWOO MOTOR (AM 12DWD10)	DWC-121C/CS(ONLY)
	3108005100	MOTOR FAN	1	DAEWOO MOTOR (AM 12DWD11)	DWA-150C/CS(ONLY)
26	7007501211	SCREW HEX	4	SX12MFZN	
27	3101802700	FAN PROPELLER	1	ABS + GF20%	
28	3102201100	WINDOW KIT FRAME(L)	1	HIPS	
29	3102201000	WINDOW KIT FRAME(R)	1	HIPS	
30	3100604200	PLATE WINDOW TOP	1	SGCC T1.2	
31	3100801400	CABINET AS	1	SGCC T0.8	
32	3100604300	BRACKET WINDOW LOWER	2	SGCC T0.8	
33	3100604500	BRACKET SILL	2	SGCC T1.6	
34	3106600600	SCROLL LOWER	1	EPS	
35	3103700100	LEVER VENT	1	PP	
36	3103700100	WASHER VENT	1	PP	
37	3104600100	RING VENT	1	NBR	
38	3106700400	CAM	1	POM	DWC-121CS
39	5S10405620	S/W ROCKER	1	R19A-2(250VAC 6A)	DWA-150CS(ONLY)
40	3107000100	CLIP THERMO	1	ABS	

No.	CODE	COMPONENTS	Q'TY	SPECIFICATION	REMARK
41	5SM0101700	THERMOSTAT AS	1	PFA 602GF	
42	5S10405100	SWITCH ROTARY	1	SR6B41610D	
43	3101300100	POWER CORD	1	16A 250V	
44	3109503100	CAPACITOR	1	40uF/370VAC	DWC-121C/CS(ONLY)
	3109503200	CAPACITOR	1	-	DWA-150C/CS(ONLY)
45	3101201600	CLAMP CAPACITOR	1	SGCC T0.6	
46	3108004800	MOTOR SWING	1	120VAC 60Hz	DWC-121CS(ONLY)
	3108002900	MOTOR SWING	1	220VAC 50/60Hz	DWA-150CS(ONLY)
47	3100508500	BOX CONTROL	1	SGCC T0.8	
48	3106600500	SCROLL UPPER	1	EPS	
49	3103002800	HOLDER SCROLL	2	SGCC	
50	3104409300	PIPE RUBBER BUTYL	1	-	
51	3102707500	HANESS COMP AS	1	UL1015-14,BLK,RED,WHT	
52	3103200500	CAP DRAIN	1	ABS	

■ DWC-121C EXPLODED DIAGRAM

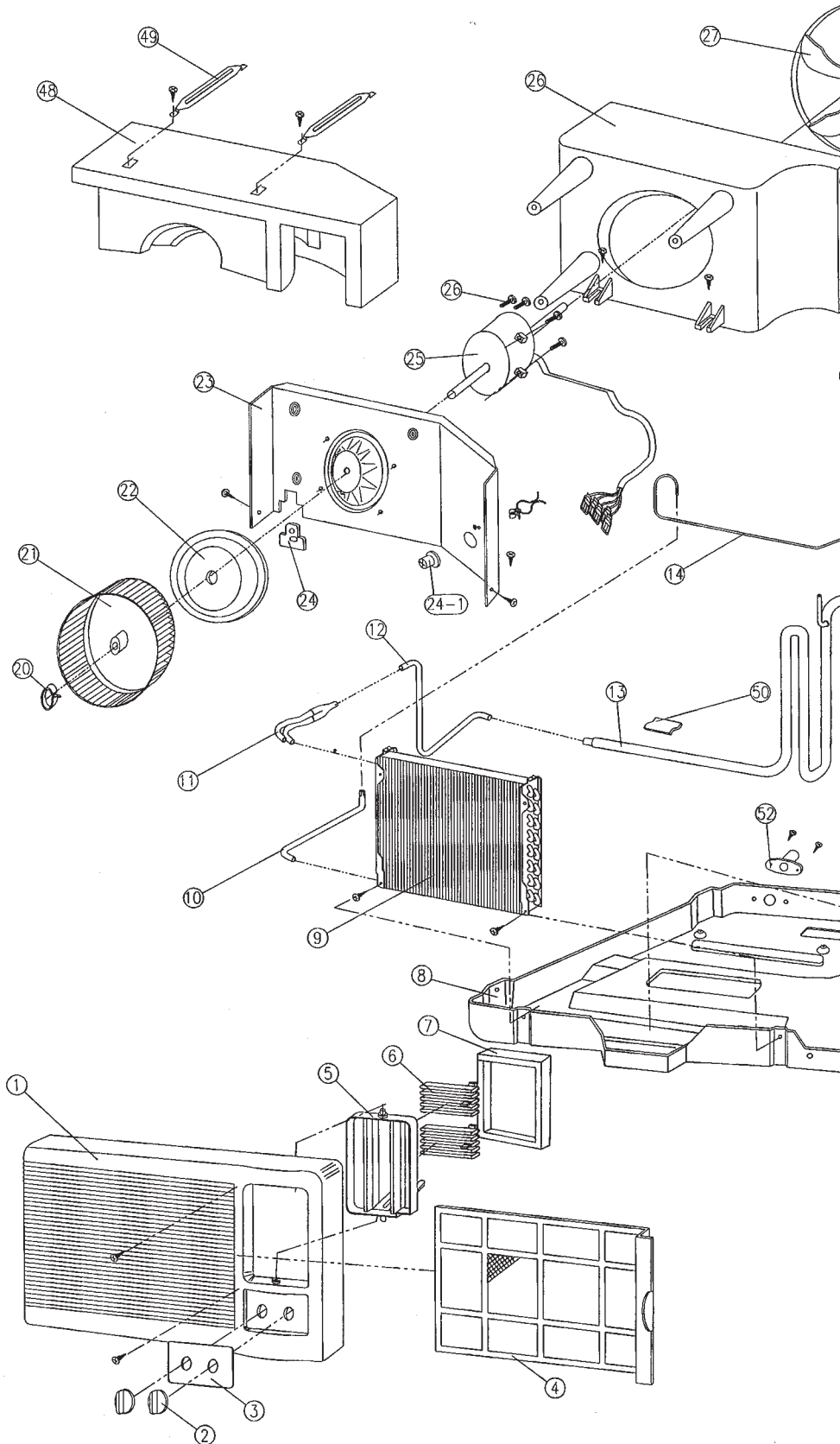

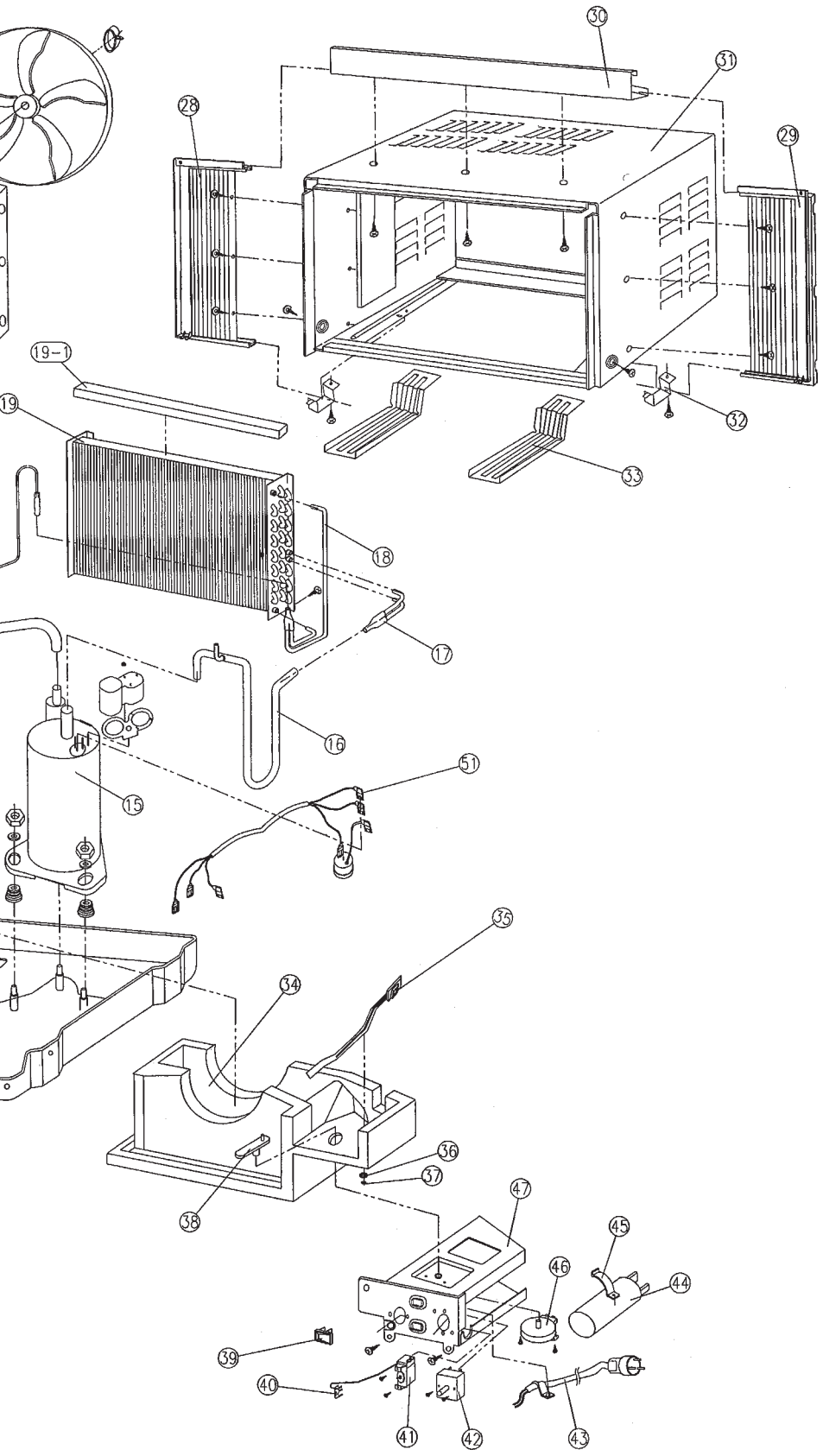

S/M NO.:

DAEWOO ELECTRONICS CO., LTD.

686, AHYEON-DONG MAPO-GU SEOUL, KOREA

C.P.O. BOX 8003 SEOUL, KOREA

TELEX: DWELEC K28177-8

CABLE: "DAEWOOELEC"

FAX: 02) 590-6291

TEL: 02) 360-7114/590-6151~5

<http://www.dwe.daewoo.co.kr>

PRINTED DATE: JAN.1999

DAEWOO

Service Manual

Window Type Room Air Conditioner

Model: DWC-121C/121CS

DWA-150C/150CS



This instrument is listed by Underwriter's Laboratories, Inc. It is designed and manufactured to meet rigid U.L. safety standards against X-radiation, fire, casualty and electrical hazards.

DAEWOO ELECTRONICS CO., LTD.



ABOUT THIS MANUAL

VISION CREATIVE, INC.

1. 2. 3. 4. 5. 6. 7. 8. 9. 10. 11. 12. 13. 14. 15. 16.

| MODEL | DWC-121C/121CS | | DWA-150C/150CS | |
|----------------|----------------|------------|----------------|--|
| BUYER | | | | |
| 1. 2. 3. 4. 5. | 1. | 99.1.12 | 6. | |
| | 2. | 99.1.20() | 7. | |
| | 3. | 99.4.22 | 8. | |
| | 4. | | 9. | |
| | 5. | | 10. | |
| MEMO | | | | |

VISION
 TEL: 757-9340 FAX: 774-1039

ABOUT THIS MANUAL

VISION CREATIVE, INC.

51526
16

| MODEL | DWC-121C/121CS DWA-150C/150CS | | |
|-------|-------------------------------|------------|----|
| BUYER | | | |
| | 1 | 99.1.12 | 6 |
| | 2 | 99.1.20() | 7 |
| | 3 | 99.4.22 | 8 |
| | 4 | | 9 |
| | 5 | | 10 |
| | | | |
| MEMO | | | |

VISION
TEL: 757-9340 FAX: 774-1039