

This Owner's Manual is provided and hosted by [Appliance Factory Parts](#).



Nexgrill T005-COPP Owner's Manual

**[Shop genuine replacement parts for Nexgrill
T005-COPP](#)**



[Find Your Nexgrill Grill Parts - Select From 922 Models](#)

----- Manual continues below -----

Nexgrill Industries ,Inc.
145, Brea Canyon Road
Walnut, CA 91789, U.S.A.

GAS-FIRED INFRARED OUTDOOR PATIO HEATER INSTALLATION, OPERATION MAINTENANCE INSTRUCTIONS



FOR MODEL T-005

TABLE OF CONTENTS	Page
IMPORTANT	1
TOOLS & PARTS.....	2
PRECAUTIONS.....	3
ASSEMBLY INSTRUCTIONS	4
GAS REQUIREMENTS & LEAK TESTING	7
LOCATING HEATER FOR USE	8
LIGHTING INSTRUCTION.....	9
SHUTDOWN INSTRUCTION.....	10
STORAGE & BURNER REMOVAL.....	11
TROUBLE SHOOTING	12
EXPLODED VIEW.....	13
WARRANTY	14

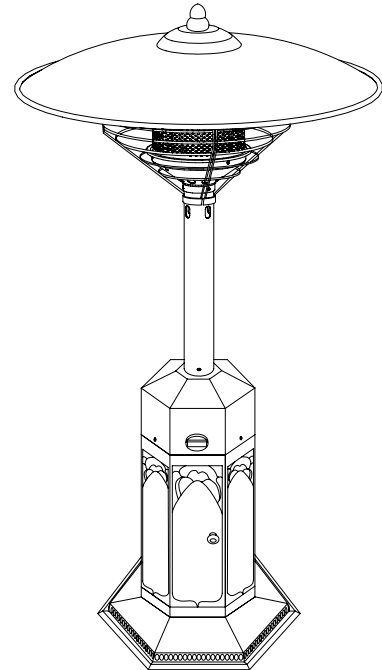

**PLEASE CONTACT 1-800-913-8999 FOR ASSISTANCE
DO NOT RETURN TO PLACE OF PURCHASE**

*** * * IMPORTANT NOTICE:**
DO NOT return to place of purchase!!!
Please contact Customer Service hotline at 800-913-8999 for help.

IMPORTANT

*** * * WARNING * * ***

For outdoor use only (outside any enclosure)

Improper operation, installation, adjustment, alteration, servicing or maintenance can cause severe property damage or serious injury or death. Please read the installation, operation & maintenance instructions thoroughly before installing or servicing this equipment.

*** * * FOR YOUR SAFETY * * ***

If you smell gas:

- Shut off gas to appliance.
- Extinguish any open flame.
- If odor continues, immediately call your gas supplier.

For your safety:

Do not store or use gasoline or other flammable vapor and liquids in the vicinity of this or any other appliance.

TOOLS AND PARTS NEEDED FOR ASSEMBLY

NOTE: Propane Gas Tank is not supplied

Tools Needed:

Phillips Screwdriver

Spray Bottle Of Soapy Water (To Check For Leaks)

Parts Supplied:

Base Assembly with Tank Cover

Post & Burner Assembly

Emitter Assembly

Emitter Screen (2)

Reflector

Reflector Dome Cap

Hardware Bag { Tank Enclosure 3/16" Screw (3)
Emitter Base 3/16" Screw (3)
Emitter Screen 3/16" Screw (4)
Reflector cap nut (1pc)

For Service Questions Replacement parts or other Assistance, Please call
VAI Customer Service Hotline at:

VAI
145 Brea Canyon Road
Walnut, CA 91789
(800)913-8999

PRECAUTION

- Do not use this space heater in an explosive atmosphere. Keep heater away from areas where gasoline or other flammable liquids or vapors are stored.
- Do not attempt to alter unit in any manner. EXAMPLE: using the heater without the top canopy reflector or radiant screen. Do not shorten the burner post assembly.
- Heater must always be placed on a solid and level surface.
- Always ensure there is ample fresh air ventilation for outdoors use ONLY.
- Never replace or substitute the regulator with any regulator other than the factory suggested replacement.
- Do not paint radiant screen, control panel or top canopy reflector.
- All leak test should be done with a soapy solution. NEVER USE AN OPEN FLAME TO CHECK FOR LEAKS.
- At least once a year the unit should be inspected for the presence of spider, spider web or other insects haven and can damage the heater and render it unsafe for use,

Check the heater immediately if any of the following exists:

1. The smell of gas in conjunction with extreme yellow tipping of the burner flames.
 2. The heater does not reach temperature.
 3. The burner makes popping noise during use (a slight popping noise is normal when the burner is extinguished).
- Children and adults should be aware of hazards of high surface temperature and shall stay away to avoid burns of clothing ignition.
 - Young children should be carefully supervised when they are in the area of the heater.
 - Clothing or other flammable material should not be hung from the heater, or placed on or near the heater.
 - Repair and services should be done by a qualified service person, the heater must be inspected before use and at least annually by a qualified service person. More frequent cleaning may be required as necessary. It is imperative that control compartment, burner and circulating air passageways of the heater be kept clean.
 - Keep the appliance area clear and free of combustion material.
 - Do not obstruct the flow of combustion and ventilation air.
 - Keep the ventilation opening of the cylinder enclosure free and clear of debris.

ASSEMBLY INSTRUCTION

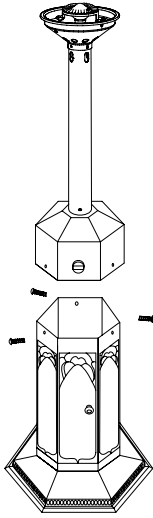

STEP 1: Connect Top Portion to Tank Enclosure

- Place top portion on of tank enclosure. Insert the three 3/16" truss head screws in three holes until tight.

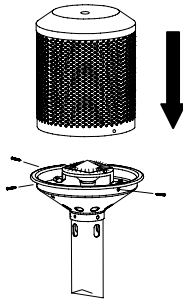

STEP 2: Attach Emitter Grid

- Line up three holes on bottom of Emitter Grid with corresponding holes in emitter bottom, fasten three 3/16"truss head screws to the emitter base.

ASSEMBLY INSTRUCTION

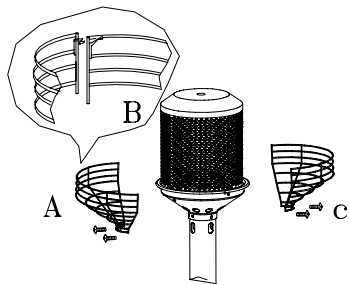

STEP 3: Attach Emitter Screen

- Attach one piece emitter screen with two truss head 3/16" screws to the post.
- Hook up two emitter screen together.
- Screw the other emitter screen on post with two truss head 3/16" screws.

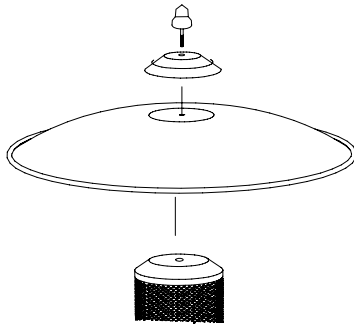

STEP 4: Attach the Reflector

- Insert threaded end of final cap nut through cap and screw into center of dome until secure.

ASSEMBLY INSTRUCTION

STEP 5: Cylinder Attachment To Heater

- Make sure gas control knob is in “OFF” position.
- Open the tank enclosure door to locate the regulator.
- Rotate gas pressure regulator outwards.
- Attach propane gas to regulator inlet fitting by turning the propane gas clockwise.
- The LP-Gas supply cylinder must be disconnected when this appliance is not in use.
- Disconnect it by turning the propane gas counter-clockwise.

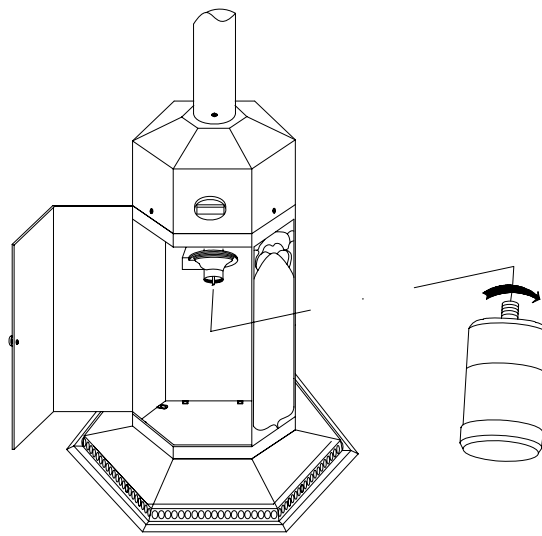

GAS REQUIREMENTS & LEAK TESTING

Gas Requirements

- The gas pressure regulator provided with this heater must be used. This regulator is set for L.P Propane units at 10.0" W.C.
- Maximum inlet pressure to propane regulator must not exceed 100 PSI.
- The pressure regulator provided with this heater must be used. This regulator is set for L.P. / Propane units at 10.0" W.C.
- The propane tank must be constructed and marked in accordance with the specifications for LP gas cylinders of the US Department of Transportation.

- A dented, rusted or damaged propane tank may be hazardous and should be checked by your tank supplier. Never use a gas tank with a damaged valve connection.

Leak Testing

- Make a soap solution of one part liquid detergent and one part water. The solution can be applied with a spray bottle, brush or rag. Soap bubbles will appear where a leak is present.
- Once the gas cylinder is securely attached make certain the control valve knob is in the 'OFF' position then check for leaks.
- If a leak is present detach the gas cylinder, tighten any leaking fitting, re-attached the gas cylinder and recheck.



Warning: Never connect an unregulated gas supply to the heater.

LOCATING HEATER FOR USE

Be Careful: When certain materials or items are left under this heater while in use, they will be subjected to radiant heat and could be seriously damaged.

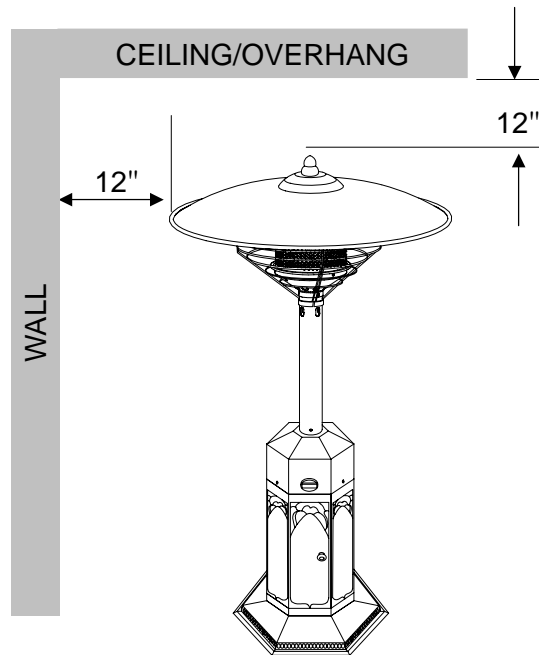

- The heater is primarily for heating of outdoor patios, decks, spas, pool and working areas.
- The minimum clearances to combustible construction shown in above must be maintained at all times
- The installation must conform to local codes or in the absence of local codes with the standard for the storage and handling of liquid petroleum gases:

In the US use : ANSI/NFPA58 on National Fuel Gas Code ANSI Z223-1998

In Canada use: National Standards of Canada. CAN/CGA B149.1 & 2-M86

LIGHTING INSTRUCTION

BEFORE TURNING ON THE GAS SUPPLY:

- Be sure all gas connections are tight and there are no leaks.
- Make sure surrounding areas are free of combustible materials, gasoline, and other flammable vapors or liquids.

BEFORE RE-LIGHTING:

For your safety, if re-lighting a hot heater, always wait at least five (5) minutes.

NOTE: 16.4 oz Propane tank must be used

TO LIGHT:

- (A) Open tank enclosure door.
- (B) Make certain regulator is connected to the gas tank. Check the connection to ensure they are tight and leak proof.
- (C) Check for leaks by applying soapy water to the tank and regulator connections.
- (D) Push and turn the gas control knob to 'HIGH' position for several seconds. It might take 2 or 3 trials to light the burner.



Warning: Keep a safe distance of at least 3 feet when attempting to ignite unit.



Avoid inhaling fumes emitted from the heater's first use. Smoke and odor from the burning of oils used in manufacturing will appear. Both smoke and odor will dissipate after approximately 30 minutes. The heater should NOT produce thick black smoke.

SHUTDOWN INSTRUCTION

WHEN HEATER IS ON:

- Emitter grid will become brighter due to intense heat. The color is more visible at night.
- Burner will display tones of blue and yellow flame. These flames should not be yellow or produce thick black smoke, indicating an obstruction of airflow through the burners. The flame should be blue with straight yellow tips.
- The flame pattern at the emitter grid should be visually checked whenever heater is operated (see figure 2). If flames extend more than 1/2 inch beyond surface of the emitter grid or reflector the heater should be turned off immediately and the heater should not be operated again until repairs are made.

FIGURE 2
NORMAL FLAME POSITION

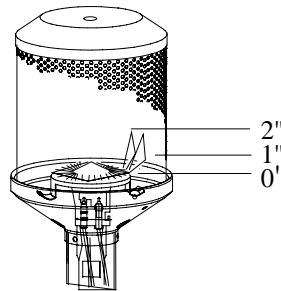

RELIGHTING

- Turn the control knob to off position.
- Wait five (5) minutes before attempting to relight burner.
- Repeat "To Light" Step (D) on prior page.

SHUT DOWN INSTRUCTIONS:

- Turn control knob clockwise to 'OFF' position. The burner may make a slight popping sound when extinguished. This is normal.
- Turn control knob clockwise to 'OFF' position when heater is not in use



This Heater contains the Tilt Safety Switch which is designed to provide safe use of the patio heater. The tilt safety switch will automatically shut-off the heater when it tilts in the trip angle over 45-60 degrees from vertical position.

TROUBLE SHOOTING

Problem	Possible Causes	Correction
Pilot won't light	<ul style="list-style-type: none">■ Air in gas line■ Low gas pressure■ Blockage in gas line	<ul style="list-style-type: none">■ Purge gas line and repeat ignition operation■ Check gas pressure■ Check gas passage way
Pilot won't stay lit	<ul style="list-style-type: none">■ Tilt switch in trip angle/OFF position■ Bad thermocouple■ Corrosion of thermocouple contact■ Safety interlock is triggered■ Bad gas valve■ Thermocouple connection loose at gas control or damaged■ Pilot flame not touching the thermocouple	<ul style="list-style-type: none">■ Reset the Heater keep in vertical position■ Replace thermocouple■ Clean thermocouple contact■ Wait a minute repeat ignition operation■ Replace gas valve■ Tighten connection or replace thermocouple■ Contact a qualified service person
Main burner won't light	<ul style="list-style-type: none">■ Low gas pressure■ Blockage in burner■ Control knob not in 'HIGH' position	<ul style="list-style-type: none">■ Check gas supply pressure■ Clean burner inside and outside■ Turn control knob to 'HIGH' position

EXPLODED VIEW

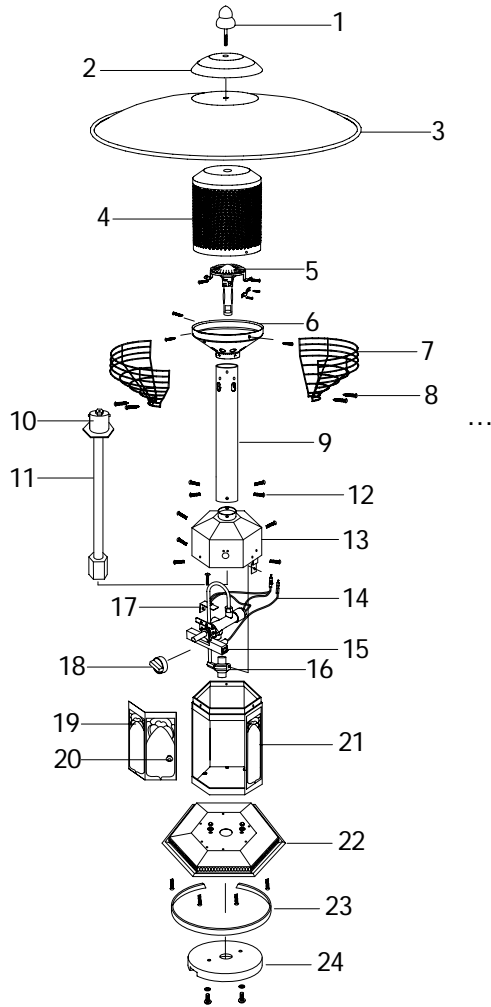

PARTS LIST

NO.	DESCRIPTIO	Q'TY
1	REFLECTOR CAP NUT	1
2	DOME CAP	1
3	REFLECTOR	1
4	EMITTER GRID	1
5	MAIN BURNER ASSEMBLY	1
6	EMITTER BASE	1
7	EMITTER SCREEN	2
8	3/16" TRUSS HEAD SCREW	17
9	POST	1
10	ORIFICE	1
11	GAS PIPE	1
12	3/16" SCREW	7
13	SHROUD COVER	1
14	PILOT ASSEMBLY	1
15	GAS VALVE CONTROL	1
16	REGULATOR	1
17	TILT SAETY SWITCH	1
18	VALVE KNOB	1
19	CYLINDER HOUSING DOOR	1
20	DOOR LATCH	1
21	CYLINDER HOUSING PANEL	1
22	BASE ASSEMBLY	1
23	RUBBER BAND	1
24	WEIGHTED BASE	

LIMITED WARRANTY
FOR T – 005
GAS-FIRED INFRARED OUTDOOR PATIO HEATER

Nexgrill Industries , Inc. warrants to the original consumer purchaser of each Outdoor Patio Heater that when subject to normal residential use, it is free from defects in workmanship and materials under normal conditions of use in a commercial application for a period of 90 days from purchase and in a residential application for a period of 1 year. Any work or repair of the heater must be performed by qualified service personal. There will be a shipping and handling charge for the delivery of the warranty part(s).

Component	Warranty Period
Burner :	3 Years
Valve :	1 Year
Pilot Kit :	1 Year
All Other Parts:	1 Year

Our obligation under this warranty is limited to repair or replacement at our option of the product during the warranty period. The extent of any liability of Nexgrill Industries , Inc. under this warranty is limited to repair or replacement. This warranty does not cover normal wear of parts, damage resulting from any of the following: negligent use or misuse of the product, use on improper fuel/gas supply, use contrary to operating instructions, or alteration by any person other than our factory service center. The warranty period is not extended by such repair or replacement.

Warranty claim procedure: If you require service or parts for your Mini Table-Top Heater, please contact our Warranty Service Center for factory direct assistance. Our hours of operation are 8 AM to 5 PM PST. Our number is 1-800-913-8999 and our FAX number is 1-909-598-7699. Please direct all correspondence to: Nexgrill Industries, Inc. *145 Brea Canyon Road, Walnut, CA 91789 ATTN: Warranty Service Center.*

Product repair as provided under this warranty is your exclusive remedy. Nexgrill Industries ,Inc.shall not be liable for any incidental or consequential damages for breach of any express or implied warranty on its products. Except to the extent prohibited by applicable law, any implied warranty or merchantability or fitness for a particular purpose on this product to the duration of the above warranty. Some states do not allow the exclusion or limitation of incidental or consequential damages or allow limitations on how long an implied warranty lasts, so the above limitations or exclusions may not apply to you. This warranty gives you specific legal rights, and you may have other rights which vary from state to state.