

This Owner's Manual is provided and hosted by [Appliance Factory Parts](#).

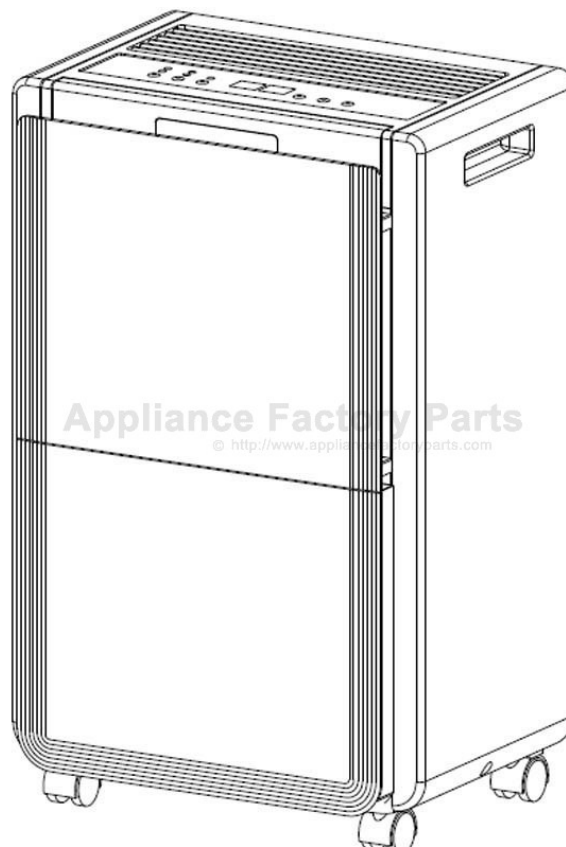

FRIEDRICH D25D Owner's Manual

[Shop genuine replacement parts for FRIEDRICH D25D](#)



[Find Your FRIEDRICH Dehumidifier Parts - Select From 35 Models](#)

----- Manual continues below -----



F R I E D R I C H

Service & Parts Manual

Dehumidifier

Models D25D, D50D, D70D

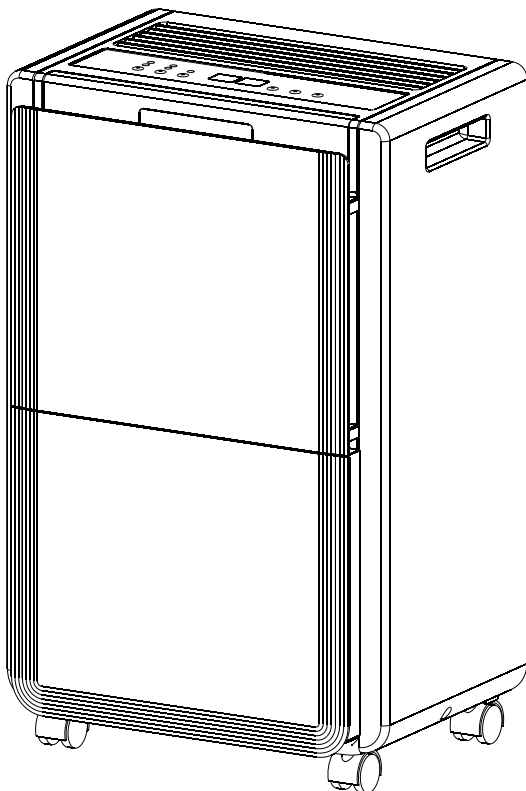

Dehumidifier-2010 Svc Parts (4-2010)

| | |
|--|------|
| Important points on service, and Flow chart for inspecting and repairing the unit | 1 |
| Troubleshooting | 2 |
| Appearance and Control panel..... | 3 |
| Technical specifications | 4-6 |
| Refrigerator system diagram | 7 |
| Schematic wiring diagram | 8 |
| Exploded view and Parts Lists | 9-12 |
| Warranty | 13 |

IMPORTANT POINTS ON SERVICE OPERATING SAFETY

Please follow these instructions carefully :

- Unplug the unit to avoid any danger from electric shock before disassembling the unit for repair.
- If there is any sound of the refrigerant circulating when in operation, avoid touching the cooling coils.
- If you need to perform any welding or soldering, be sure you are in a well ventilated area.
- Only a qualified professional should perform any welding on the unit.
- When repairing the unit, the specifications listed in this manual must be strictly adhered to when replacing any components.
- When replacing any electrical components they should be factory approved units.
- Be sure that any electrical components are properly wired and in place.

FLOW CHART FOR INSPECTING AND REPAIRING THE UNIT

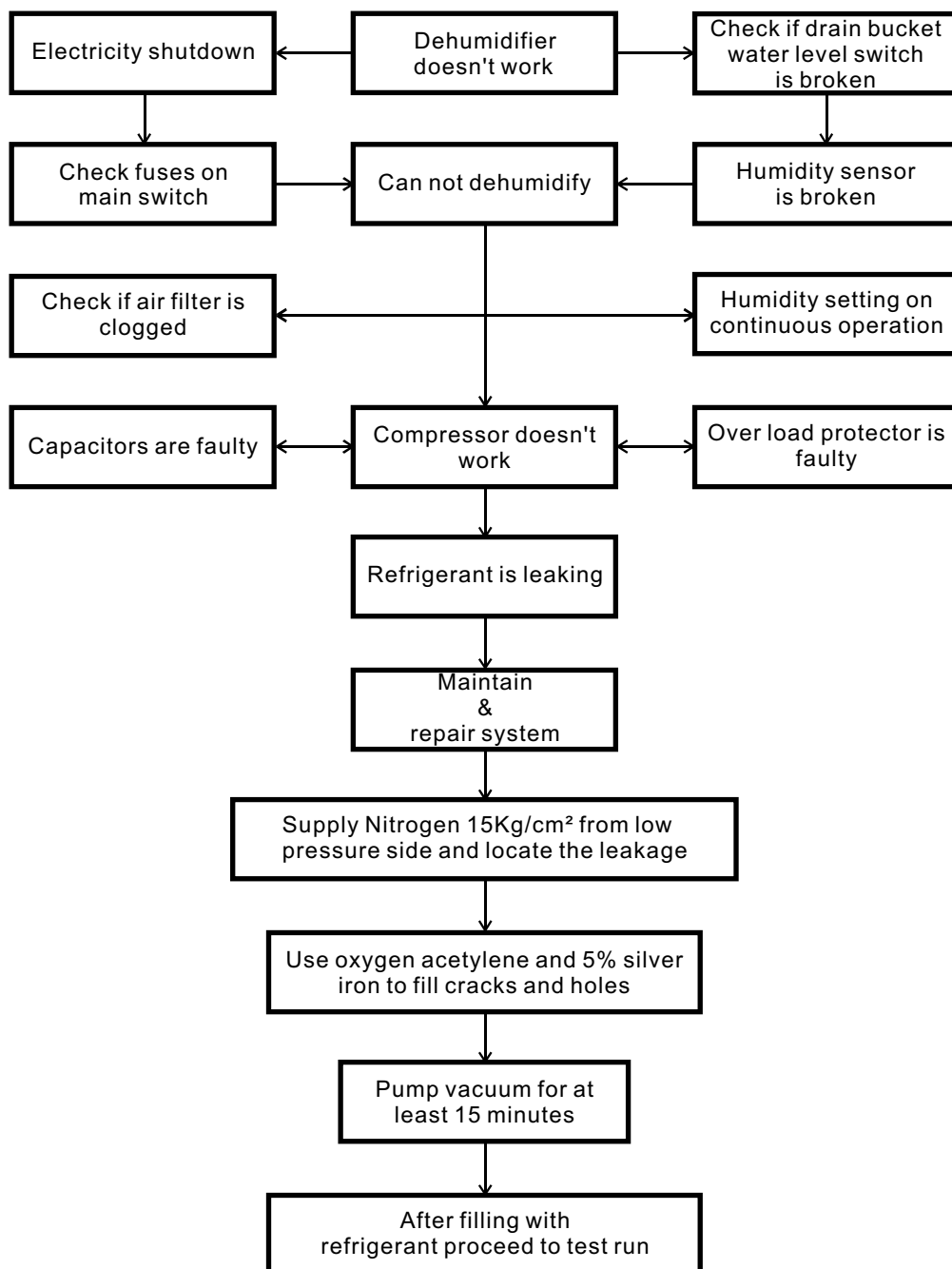

TROUBLESHOOTING

| Problem | Possible causes | Solution |
|--|-------------------------------------|---|
| Dehumidifier doesn't work | Electricity shutdown or low voltage | Wait for electricity to be restored |
| | Bad plug or wire is broken | Repair or replace |
| Fan doesn't work | Motor is broken | Repair or replace |
| Compressor doesn't work | Low voltage | Call the local electricity company |
| | Still under the 3 min protection | Wait until it goes back to function after 3 min |
| | Compressor is broken | Repair or replace |
| Can not dehumidify or the dehumidification volume is too low | Filter is dirty | Clean filter |
| | Refrigerant is leaking | Detect the leakage and fill with refrigerant |
| | Low temp and humidity | Normal |
| Loud noise and vibration | Uneven floor | Move to level place or use blocks |
| | Motor or compressor is loose | Tighten screws |
| | Sound of flowing water | Normal, it is the sound when the refrigerant is flowing |
| Evaporator is frosted | Filter is too dirty | Clean filter |
| | Environment temp is too low | Stop use temporarily |
| Dehumidification water overflows | Drain bucket is broken | Repair or replace |
| | Micro switch is broken | Repair or replace |

APPEARANCE

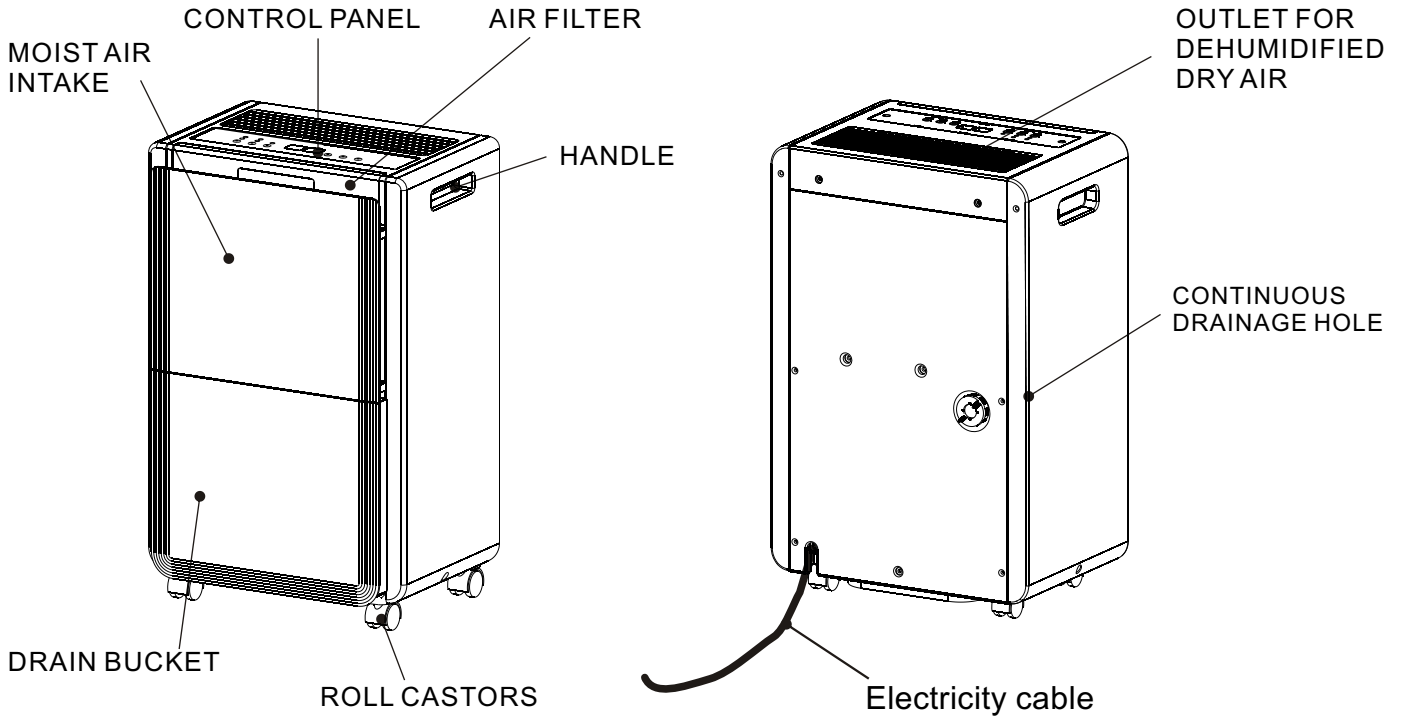

CONTROL PANEL

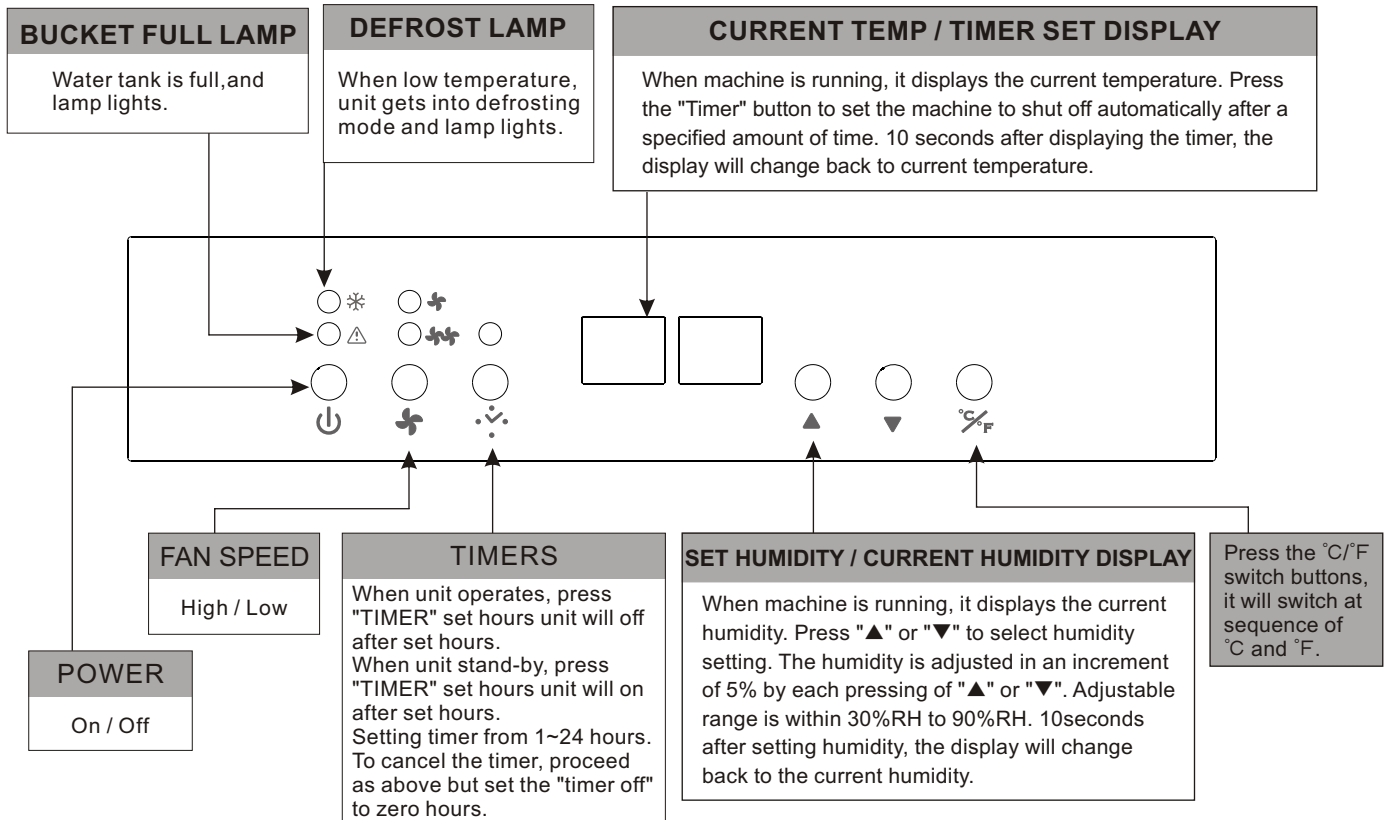

TECHNICAL SPECIFICATIONS

| ITEM | | UNIT | D25D |
|------------------------|-----------------|----------|-----------------------------------|
| DEHUMIDIFYING CAPACITY | | Pint/day | 25 (at 80°F , 60%RH) |
| OUTER DIMENSION | | Inches | 13.46(W) * 21.46(H) * 9.84(D) |
| RATED VOLTAGE | | V/Hz | 115 / 60 |
| RUNNING CURRENT | | A | 4.6 |
| WIRE SPECIFICATION | | | 10A 125V 18AWG*3C |
| COMPRESSOR | MODEL | | 35D042-A2-ABDA |
| | INPUT POWER | W | 300 |
| | OPERATING CYCLE | uF/V | 35/300 |
| | PROTECTOR | | MRA12228-12095 |
| FAN MOTOR | MODEL | | LS-16T2-04 |
| | INPUT POWER | W | 47 |
| | OPERATING CYCLE | uF/V | 5/250 |
| CAPILLARY | | Inches | 0.086(O.D.)*0.047(I.D.)*19.685(L) |
| EVAPORATOR | | | 1R10S21FPI |
| CONDENSER | | | 2R10S21FPI |
| REFRIGERANT | | R410A/oz | 5.28 |
| WEIGHT | | Lbs | 32 |
| WATER TANK CAPACITY | | Pint | 11 |
| | | | |
| | | | |

TECHNICAL SPECIFICATIONS

| ITEM | | UNIT | D50D |
|------------------------|-----------------|----------|----------------------------------|
| DEHUMIDIFYING CAPACITY | | Pint/day | 50 (at 80°F , 60%RH) |
| OUTER DIMENSION | | Inches | 14.96(W) * 23.43(H) * 12.01(D) |
| RATED VOLTAGE | | V/Hz | 115 / 60 |
| RUNNING CURRENT | | A | 5.9 |
| WIRE SPECIFICATION | | | 10A 125V 18AWG*3C |
| COMPRESSOR | MODEL | | 35D052-A2-ABLL |
| | OPERATING CYCLE | uF/V | 40/300 |
| | PROTECTOR | | MRA12274-12095 |
| | | | |
| FAN MOTOR | MODEL | | LS-16T2-02-N2 |
| | INPUT POWER | W | 47 |
| | OPERATING CYCLE | uF/V | 6/250 |
| CAPILLARY | | Inches | 0.086(O.D.)*0.047(I.D.)*39.37(L) |
| EVAPORATOR | | | 2R12S21FPI |
| CONDENSER | | | 2R12S21FPI |
| REFRIGERANT | | R410A/oz | 9.32 |
| WEIGHT | | Lbs | 44 |
| WATER TANK CAPACITY | | Pint | 16 |
| | | | |
| | | | |

TECHNICAL SPECIFICATIONS

| ITEM | | UNIT | D70D |
|------------------------|-----------------|----------|----------------------------------|
| DEHUMIDIFYING CAPACITY | | Pint/day | 70 (at 80°F , 60%RH) |
| OUTER DIMENSION | | Inches | 14.96(W) * 23.43(H) * 12.01(D) |
| RATED VOLTAGE | | V/Hz | 115 / 60 |
| RUNNING CURRENT | | A | 7.7 |
| WIRE SPECIFICATION | | | 10A 125V 18AWG*3C |
| COMPRESSOR | MODEL | | 41T068-A2-AMLI |
| | OPERATING CYCLE | uF/V | 40/300 |
| | PROTECTOR | A | MRA12272-12082 |
| | | | |
| FAN MOTOR | MODEL | | LS-16T2-06 |
| | INPUT POWER | W | 47 |
| | OPERATING CYCLE | uF/V | 6/250 |
| CAPILLARY | | Inches | 0.086(O.D.)*0.047(I.D.)*31.50(L) |
| EVAPORATOR | | | 2R12S21FPI |
| CONDENSER | | | 2R12S21FPI |
| REFRIGERANT | | R410A/oz | 12.03 |
| WEIGHT | | Lbs | 44 |
| WATER TANK CAPACITY | | Pint | 16 |
| | | | |
| | | | |

REFRIGERATOR SYSTEM DIAGRAM

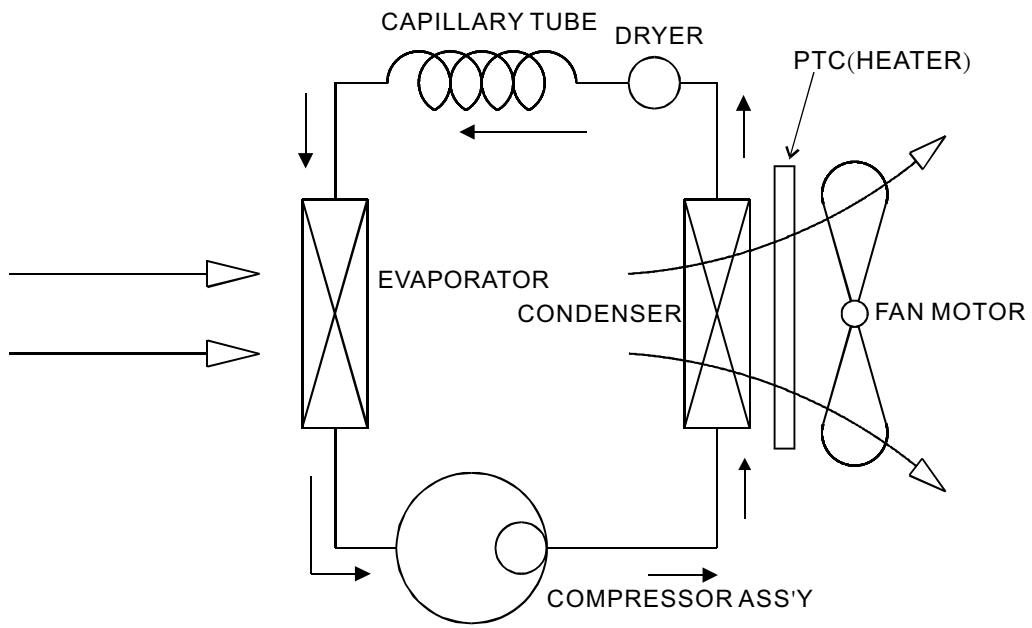

SCHEMATIC WIRING DIAGRAM

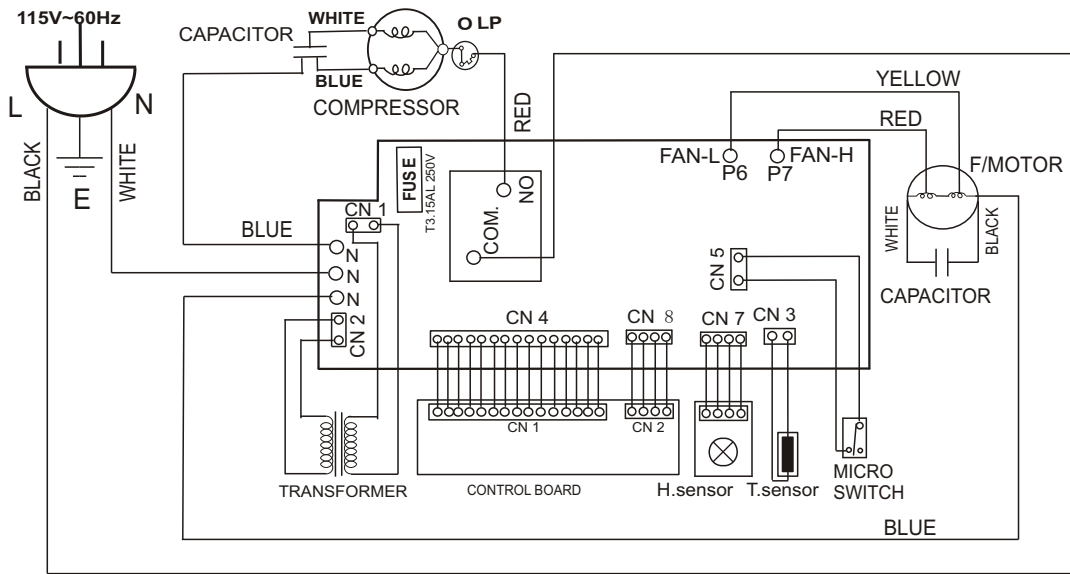

D6951-870

SCHEMATIC WIRING DIAGRAM

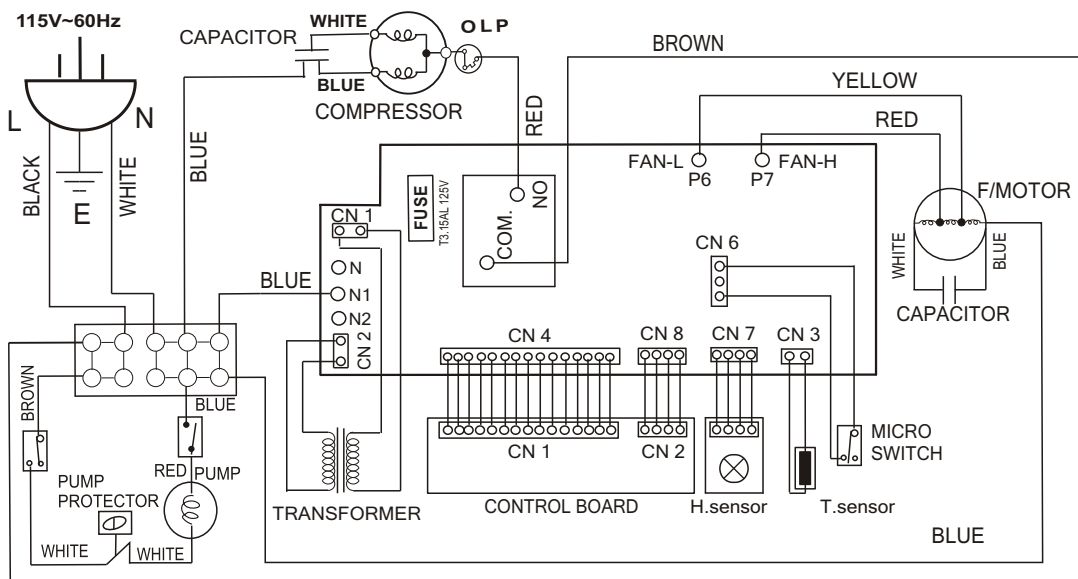

D6951-900

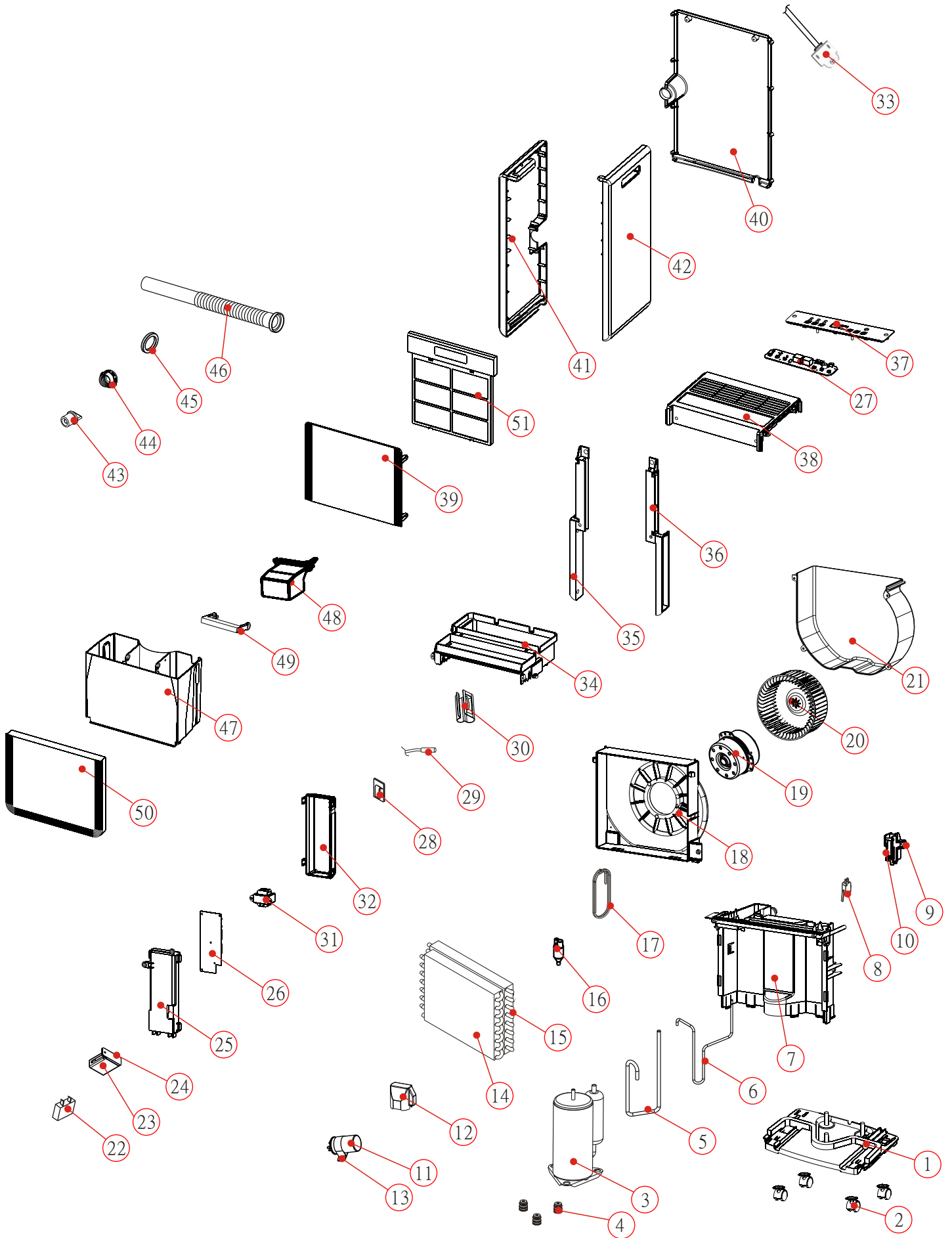

D25D Service Parts List

| Ref # | Friedrich Part # | Description | Qty | Notes |
|-------|------------------|------------------------------|-----|-------|
| 1 | 679-041-52 | BASE PAN | 1 | |
| 2 | 679-042-07 | CASTERS | 4 | |
| 3 | 679-041-24 | COMPRESSOR ASS'Y | 1 | |
| 4 | 679-041-65 | COMPRESSOR GROMMETS | 3 | |
| 7 | 679-041-68 | PLATE | 1 | |
| 8 | 679-041-00 | MICRO SWITCH | 1 | |
| 9 | 679-041-76 | FIXTURE | 1 | |
| 10 | 679-042-08 | BAR | 1 | |
| 11 | 679-041-11 | CAPACITOR (35uF/300V) | 1 | |
| 12 | 679-041-08 | COVER | 1 | |
| 13 | 679-041-05 | CAPACITOR STRAP | 1 | |
| 14 | 679-041-29 | EVAPORATOR ASS'Y | 1 | |
| 15 | 679-041-32 | CONDENSER ASS'Y | 1 | |
| 16 | 679-041-28 | STRAINER | 1 | |
| 17 | 679-041-85 | CAPILLARY TUBE | 1 | |
| 18 | 679-041-54 | INNER WALL (MOTOR MOUNT) | 1 | |
| 19 | 679-041-21 | FAN MOTOR | 1 | |
| 20 | 679-041-57 | BLOWER WHEEL | 1 | |
| 21 | 679-041-55 | FAN SHROUD | 1 | |
| 22 | 679-041-13 | PLASTIC CAPACITOR (5uF/250V) | 1 | |
| 23 | 679-041-84 | CAPACITOR COVER | 1 | |
| 24 | 679-041-81 | CAPACITOR MOUNT | 1 | |
| 25 | 679-041-77 | CONTROL HOUSING | 1 | |
| 26 | 679-041-15 | ELECTRONIC CONTROL BOARD | 1 | |
| 27 | 679-041-16 | CONTROL PANEL BOARD | 1 | |
| 28 | 679-041-19 | SENSOR | 1 | |
| 29 | 679-041-17 | THERMISTOR SENSOR | 1 | |
| 31 | 679-041-20 | TRANSFORMER | 1 | |
| 32 | 679-041-82 | CONTROL HOUSING COVER | 1 | |
| 33 | 679-041-34 | POWER SUPPLY CORD | 1 | |
| 34 | 679-041-79 | FIX TUBE | 1 | |
| 35 | 679-041-71 | LEFT RAIL | 1 | |
| 36 | 679-041-73 | RIGHT RAIL | 1 | |
| 37 | 679-041-50 | CONTROL PANEL OVERLAY | 1 | |
| 38 | 679-041-46 | DISCHARGE GRILLE | 1 | |
| 39 | 679-041-42 | DECORATIVE PANEL | 1 | |
| 40 | 679-041-39 | REAR PANEL | 1 | |
| 41 | 679-041-35 | LEFT SIDE PLATE | 1 | |
| 42 | 679-041-37 | RIGHT SIDE PLATE | 1 | |
| 43 | 679-042-06 | SOFT PLUG CAP | 1 | |
| 44 | 679-042-05 | SCREW-IN PLUG CAP | 1 | |
| 45 | 679-041-17 | WASHER | 1 | |
| 46 | 679-042-01 | DRAIN PIPE | 1 | |
| 47 | 679-041-60 | DRAIN BUCKET | 1 | |
| 48 | 679-041-62 | FLOAT | 1 | |
| 49 | 679-041-48 | TANK HANDLE | 1 | |
| 50 | 679-041-44 | DECORATING TANK FRONT | 1 | |
| 51 | 679-042-02 | AIR FILTER | 1 | |

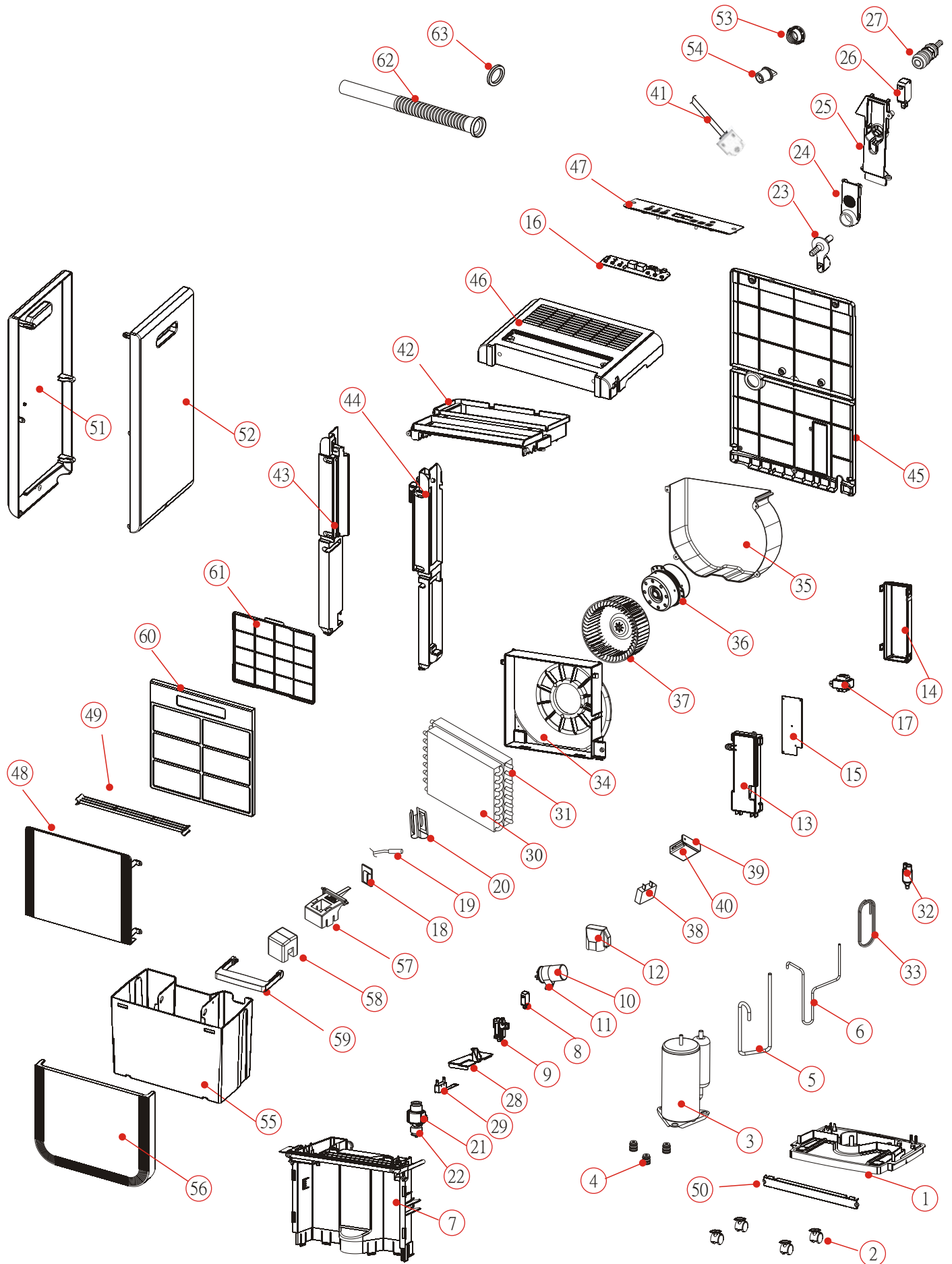

D50D & D70D Service Parts List

| Ref # | Friedrich Part # | | Description | Qty | Notes |
|-------|------------------|------------|------------------------------|-----|-------|
| | D50D | D70D | | | |
| 1 | 679-041-53 | 679-041-53 | BASE PAN | 1 | |
| 2 | 679-042-07 | 679-042-07 | CASTERS | 4 | |
| 3 | 679-041-25 | 679-041-26 | COMPRESSOR ASS'Y | 1 | |
| 4 | 679-041-67 | 679-041-67 | COMPRESSOR GROMMETS | 3 | |
| 7 | 679-041-69 | 679-041-69 | PLATE | 1 | |
| 8 | 679-041-00 | 679-041-00 | MICRO SWITCH | 1 | |
| 9 | 679-041-76 | 679-041-76 | FIXTURE | 1 | |
| 10 | 679-041-12 | 679-041-12 | CAPACITOR (40uF/300V) | 1 | |
| 11 | 679-041-06 | 679-041-06 | CAPACITOR STRAP | 1 | |
| 12 | 679-041-09 | 679-041-09 | COVER | 1 | |
| 13 | 679-041-78 | 679-041-78 | CONTROL HOUSING | 1 | |
| 14 | 679-041-82 | 679-041-82 | CONTROL HOUSING COVER | 1 | |
| 15 | 679-041-15 | 679-041-15 | ELECTRONIC CONTROL BOARD | 1 | |
| 16 | 679-041-16 | 679-041-16 | CONTROL PANEL | 1 | |
| 17 | 679-041-20 | 679-041-20 | TRANSFORMER | 1 | |
| 18 | 679-041-19 | 679-041-19 | SENSOR | 1 | |
| 19 | 679-041-18 | 679-041-18 | THERMISTOR SENSOR | 1 | |
| 20 | 679-041-75 | 679-041-75 | FIX METAL | 1 | |
| 21 | 679-041-01 | 679-041-01 | WATER PUMP | 1 | |
| 22 | 679-041-66 | 679-041-66 | GROMMETS FOR PUMP | 2 | |
| 23 | 679-041-04 | 679-041-04 | PUMP HOSE CONNECTOR | 1 | |
| 24 | 679-041-03 | 679-041-03 | PUSH BUTTON SWITCH FOR PUMP | 1 | |
| 25 | 679-041-07 | 679-041-07 | FIX TUBE | 1 | |
| 26 | 679-041-00 | 679-041-00 | MICRO SWITCH | 1 | |
| 27 | 679-041-02 | 679-041-02 | QUICK CONNECTOR FOR PUMP | 1 | |
| 28 | 679-041-83 | 679-041-83 | DRAIN BUCKET COVER | 1 | |
| 29 | 679-041-10 | 679-041-10 | MICRO SWITCH | 1 | |
| 30 | 679-041-30 | 679-041-31 | EVAPORATOR ASS'Y | 1 | |
| 31 | 679-041-33 | 679-041-33 | CONDENSER ASS'Y | 1 | |
| 32 | 679-041-28 | 679-041-28 | STRAINER | 1 | |
| 33 | 679-041-86 | 679-041-87 | CAPILLARY TUBE | 1 | |
| 34 | 679-041-59 | 679-041-59 | INNER WALL / MOTOR MOUNT | 1 | |
| 35 | 679-041-56 | 679-041-56 | FAN SHROUD | 1 | |
| 36 | 679-041-22 | 679-041-23 | FAN MOTOR | 1 | |
| 37 | 679-041-58 | 679-041-58 | BLOWER WHEEL | 1 | |
| 38 | 679-041-14 | 679-041-14 | PLASTIC CAPACITOR (6uF/250V) | 1 | |
| 39 | 679-041-81 | 679-041-81 | CAPACITOR MOUNT | 1 | |
| 40 | 679-041-84 | 679-041-84 | CAPACITOR COVER | 1 | |
| 41 | 679-041-34 | 679-041-34 | POWER SUPPLY CORD | 1 | |
| 42 | 679-041-80 | 679-041-80 | FIX TURE | 1 | |
| 43 | 679-041-70 | 679-041-70 | LEFT RAIL | 1 | |
| 44 | 679-041-72 | 679-041-72 | RIGHT RAIL | 1 | |
| 45 | 679-041-40 | 679-041-40 | REAR PANEL | 1 | |
| 46 | 679-041-47 | 679-041-47 | DISCHARGE GRILLE | 1 | |
| 47 | 679-041-51 | 679-041-51 | CONTROL PANEL OVERLAY | 1 | |
| 48 | 679-041-43 | 679-041-43 | DECORATIVE PANEL | 1 | |
| 49 | 679-041-74 | 679-041-74 | STRIKE | 1 | |
| 50 | 679-041-45 | 679-041-45 | DECORATING PLATE FOR BASE | 1 | |
| 51 | 679-041-36 | 679-041-36 | LEFT SIDE PLATE | 1 | |
| 52 | 679-041-38 | 679-041-38 | RIGHT SIDE PLATE | 1 | |
| 53 | 679-042-05 | 679-042-05 | SCREW IN PLUG CAP | 1 | |
| 54 | 679-042-06 | 679-042-06 | SOFT PLUG CAP | 1 | |
| 55 | 679-041-61 | 679-041-61 | DRAIN BUCKET | 1 | |
| 56 | 679-041-41 | 679-041-41 | DECORATIVE TANK FRONT | 1 | |
| 57 | 679-041-63 | 679-041-63 | FLOAT | 1 | |
| 58 | 679-041-64 | 679-041-64 | FLOAT CAP | 1 | |
| 59 | 679-041-49 | 679-041-49 | TANK HANDLE | 1 | |
| 60 | 679-042-03 | 679-042-03 | AIR FILTER | 1 | |
| 62 | 679-042-01 | 679-042-01 | DRAIN PIPE | 1 | |
| 63 | 679-041-27 | 679-041-27 | WASHER | 1 | |



Friedrich Air Conditioning Company
P.O. Box 1540
San Antonio, TX 78295
210.357.4400
www.friedrich.com

DEHUMIDIFIERS LIMITED WARRANTY

FIRST YEAR

ANY PART: If any part supplied by FRIEDRICH fails because of a defect in workmanship or material within twelve months from date of original purchase, FRIEDRICH will repair the product at no charge, provided the product is transported to a Friedrich Authorized Service Center for repair. ALL transportation charges are the sole responsibility of the owner. This remedy is expressly agreed to be the exclusive remedy within twelve months from the date of the original purchase.

SECOND THROUGH FIFTH YEAR

SEALED REFRIGERANT SYSTEM: If the Sealed Refrigeration System (defined for this purpose as the compressor, condenser coil, dehumidifying coil, capillary, filter drier, and all interconnecting tubing) supplied by FRIEDRICH in your dehumidifier fails because of a defect in workmanship or material within sixty months from date of purchase, FRIEDRICH will pay a labor allowance and parts necessary to repair the Sealed Refrigeration System; **PROVIDED** FRIEDRICH will not pay the cost of diagnosis of the problem, removal, freight charges, and transportation of the dehumidifier to and from the Service Agency, and the reinstallation charges associated with repair of the Sealed Refrigeration System. All such cost will be the sole responsibility of the owner. This remedy is expressly agreed to be the exclusive remedy within sixty months from the date of the original purchase.

APPLICABILITY AND LIMITATIONS: This warranty is applicable only to units retained within the Fifty States of the U.S.A., District of Columbia, and Canada. This warranty is not applicable to:

1. Air filters or fuses.
2. Products on which the model and serial numbers have been removed.
3. Products which have defects or damage which results from improper installation, wiring, electrical current characteristics, or maintenance; or caused by accident, misuse or abuse, fire, flood, alterations and/or misapplication of the product and/or units installed in a corrosive atmosphere, default or delay in performance caused by war, government restrictions or restraints, strikes, material shortages beyond the control of FRIEDRICH, or acts of God.

OBTAINING WARRANTY PERFORMANCE: Service will be provided by the **FRIEDRICH Authorized Dealer or Service Organization** in your area. They are listed in the Yellow Pages. If assistance is required in obtaining warranty performance, write to: Room Air Conditioner Service Manager, Friedrich Air Conditioning Co., P.O. Box 1540, San Antonio, TX 78295-1540.

LIMITATIONS: THIS WARRANTY IS GIVEN IN LIEU OF ALL OTHER WARRANTIES. Anything in the warranty notwithstanding, ANY IMPLIED WARRANTIES OF FITNESS FOR PARTICULAR PURPOSE AND/OR MERCHANTABILITY SHALL BE LIMITED TO THE DURATION OF THIS EXPRESS WARRANTY. MANUFACTURER EXPRESSLY DISCLAIMS AND EXCLUDES ANY LIABILITY FOR CONSEQUENTIAL OR INCIDENTAL DAMAGE FOR BREACH OF ANY EXPRESSED OR IMPLIED WARRANTY.

NOTE: Some states do not allow limitations on how long an implied warranty lasts, or do not allow the limitation or exclusion of consequential or incidental damages, so the foregoing exclusions and limitations may not apply to you.

OTHER: This warranty gives you specific legal rights, and you may also have other rights which vary from state to state.

PROOF OF PURCHASE: Owner must provide proof of purchase in order to receive any warranty related services.

All service calls for explaining the operation of this product will be the sole responsibility of the consumer.

All warranty service must be provided by an **Authorized FRIEDRICH Service Agency**, unless authorized by FRIEDRICH prior to repairs being made.

(2-10)