

This Owner's Manual is provided and hosted by [Appliance Factory Parts](#).



# Koblenz RM1715 Owner's Manual

[Shop genuine replacement parts for Koblenz RM1715](#)



[Find Your Koblenz Vacuum Cleaner Parts - Select From 30 Models](#)

----- Manual continues below -----

## VII.- ASSEMBLY POLISHER

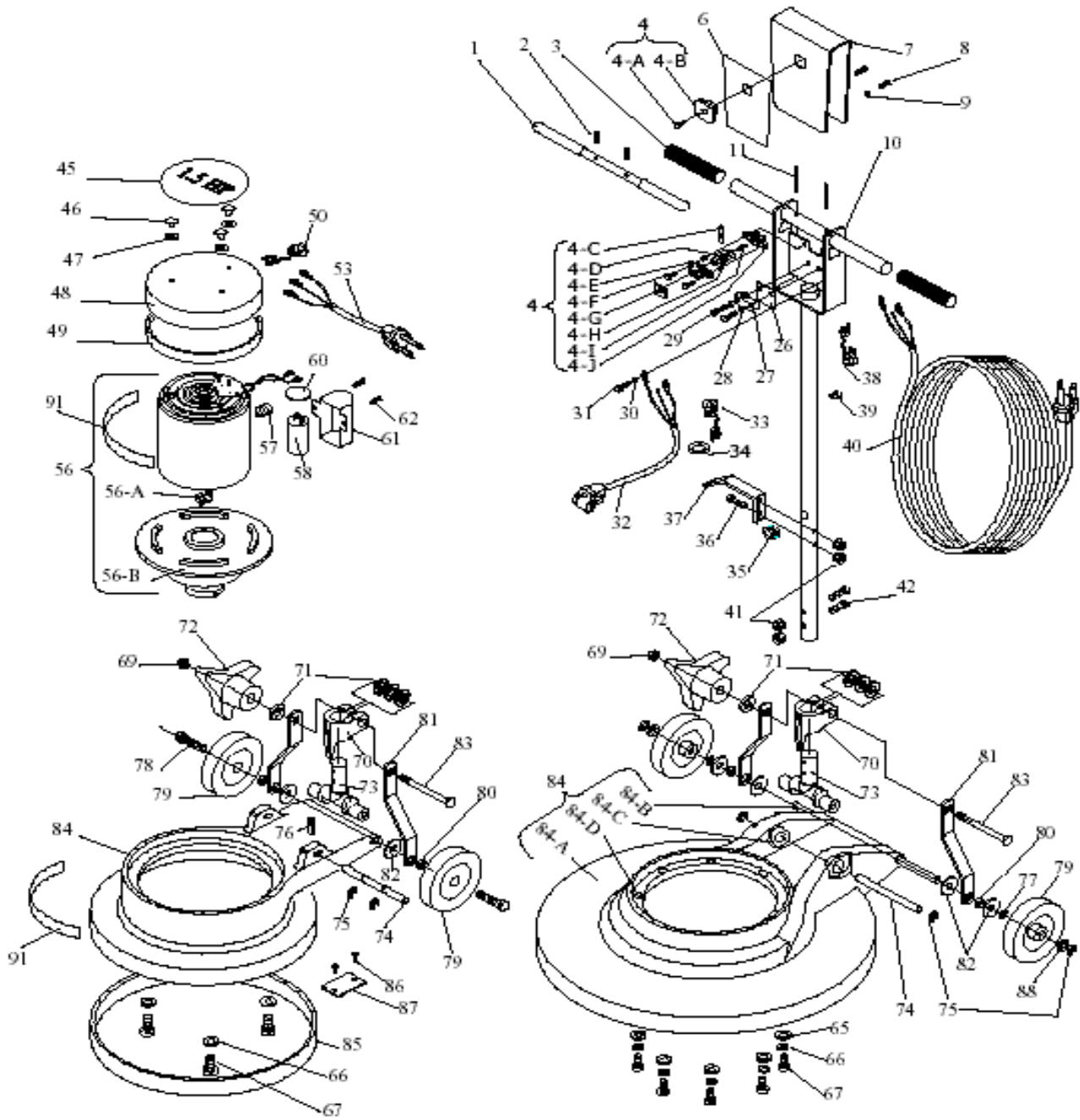

**INDUSTRIAL POLISHER SERIES "DP Y RM "**

September / 2006

## VI.- PART LIST

No	PART	DESCRIPTION	TP 1334	TP 1710	TP 1715	TP 2010	TP 2015	TP 2S 2015 DC	RM 1715	RM 2015
1	05-3979-1	Starter Lever	1	1	1	1	1	1	1	1
2	24-0292-3	Spring	2	2	2	2	2	2	2	2
3	12-0830-5	handle Tube Upper	2	2	2	2	2	2	2	2
4	45-0534-3	Kit spare Assembles Sure	1	1	1	1	1	1	1	1
4-A	01-0272-3	Screw # 6x ½	1	1	1	1	1	1	1	1
4-B	13-2209-8	Sure Button	1	1	1	1	1	1	1	1
4-C	13-2205-6	Piston of the Insurance	1	1	1	1	1	1	1	1
4-D	13-2206-4	Sure	1	1	1	1	1	1	1	1
4-E	13-2208-0	It cover Box it Guides of the insurance	1	1	1	1	1	1	1	1
4-F	01-1732-5	Screw # 8-32x1/2	2	2	2	2	2	2	2	2
4-G	37-0225-5	Dust Cover	1	1	1	1	1	1	1	1
4-H	05-3536-9	Tubular Separator	2	2	2	2	2	2	2	2
4-I	24-0292-3	Spring	1	1	1	1	1	1	1	1
4-J	13-2207-2	Box Guides Of the Insurance	1	1	1	1	1	1	1	1
6	17-3782-4	Switch Box Label Polisher	1	1	1	1	1	1	1	1
7	05-3975-9	Switch Box Cover Black	1	1	1	1	1	1	1	1
8	01-1984-2	Screw #8-32x1"	2	2	2	2	2	2	2	2
9	04-0276-8	Star Washer # 8	2	2	2	2	2	2	2	2
10	23-0655-3	Assemble handle		1	1	1	1	1		
10	23-0704-9	Assemble handle	1						1	1
11	03-0593-8	Bolt with Head	2	2	2	2	2	2	2	2
26	08-1857-5	Insulator Switch	1	1	1	1	1	1	1	1
27	11-0096-5	Micro Switch	1	1	1	1	1	1	1	1
28	04-0275-0	Star Washer # 6	2	2	2	2	2	2	2	2
29	01-0851-4	Screw Hexagonal # 6-32 x 1"	2	2	2	2	2	2	2	2
30	04-0493-9	Star Washer # 8	1	1	1	1	1	1	1	1
31	01-0852-2	Screw Hexagonal #6-32x3/8"	1	1	1	1	1	1	1	1
32	28-0672-7	Motor Cable /Contact assembly	1	1	1	1	1	1	1	1
33	12-0414-8	Grommet Heyco 0.062	1	1	1	1	1	1	1	1
34	04-0036-6	Washer	1	1	1	1	1	1	1	1
35	12-0115-1	Grommet of Rubber	1	1	1	1	1	1	1	1
36	01-1724-2	Allen Screw 5/16-24x3/4"		1	1	1	1	1		
36	01-0870-4	Screw Hexagonal ¼-20x3/4"	2						2	2
37	06-0486-8	Hook Cord		1	1	1	1	1		
37	05-4275-3	Hook Cord	1					1	1	1
38	45-0456-9	Grommet Assembly		1	1	1	1	1		
38	12-0313-2	Grommet Heyco 0.187	1						1	1
39	10-0140-3	Connector of Pressure 2 x 14	1	1	1	1	1	1	1	1
40	28-1078-6	Line Cord Assembly	1	1	1	1	1	2	1	1
41	02-0092-3	Elastic Nut ¼-20	2	2	2	2	2	2	2	2
42	01-1769-7	Screw Hexagonal Head	2	2	2	2	2	1	2	2

No	PART	DESCRIPTION	TP 1334	TP 1710	TP 1715	TP 2010	TP 2015	TP 2S 2015 DC	RM 1715	RM 2015
45	17-3035-7	1.0 HP Label		1		1				
45	17-3845-9	¾ HP Label	1							
45	17-3036-5	1.5 HP Label			1		1	1	1	1
45	17-3882-2	2 Speed Label		1				1		
46	01-1731-7	Screw ( 10-32x ¼ " )	3						3	3
47	04-0100-0	Washer	3						3	3
48	05-3998-1	Motor Cover Black	1							
48	05-3765-4	Motor Cover		1	1	1	1			
48	05-4373-6	Motor Cover Gray							1	1
48	05-3981-7	2 Speed Motor Cover		1						
49	12-0829-7	Motor Top Cover Gasket	1						1	1
49	12-0692-9	Motor Top Cover Gasket		1	1	1	1	1		
50	12-0414-8	Grommet Heyco 0.062	1	1	1	1	1	1	1	1
51	10-0140-3	Pressure Connector		1				1		
52	01-1626-9	Screw		1				1		
53	28-0671-9	Motor Cable / Contact Assembly	1	1	1	1	1		1	1
53	28-1079-4	Motor Cable /Contact Assembly 2 Speed		1				1		
54	17-3788-1	Label Speed Low / High		1				1		
55	11-0181-5	Switch On-Off		2				1		
56	46-2793-1	Motor/Trans Gear Box 3/4	1							
56	46-2372-4	Motor/Trans Gear Box 1.0 HP		1		1				
56	46-2373-2	Motor/Trans Gear Box 1.5 HP		1		1				
56	44-0346-5	Motor/Trans Gear Box 1.5 HP 2 Speed						1		
56	46-3114-9	Motor/Trans Gear Box 1.5 HP							1	1
56-A	45-0394-2	Reduction Coupling	1	1	1	1	1	1	1	1
56-B	46-2887-1	¾ reduction Assembly	1	1	1	1	1			
56-B	46-2214-8	Reduction Assembly								
56-B	46-3117-2	1.5 Reduction Assembly							1	1
57	12-0024-5	Grommet	1	1	2	1	2		1	1
58	15-0012-3	Capacitor 540-648-MF		1		1			1	1
58	15-0011-5	Capacitor 400-480 MF	1							
58	15-0013-1	Capacitor 590-708 MF			1		1			
59	15-0678-1	Capacitor 40 MF			1		1			
60	08-0979-8	Capacitor Insulator	1	1	2	1	2		1	1
61	05-0211-2	Capacitor Cover Black	1							
61	05-3567-4	Capacitor Cover Chromed		1	2	1	2			
61	05-3568-2	Capacitor Cover Gray							1	1
62	01-1093-2	Tapping Screw 8x3/8 "	2	2	4	2	4		2	2

No	PART	DESCRIPTION	TP 1334	TP 1710	TP 1715	TP 2010	TP 2015	TP 2S 2015 DC	RM 1715	RM 2015
63	23-0587-8	Motor Cover 1.5 HP			1		1			
63	23-0588-6	Motor Cover 1.5 HP		1		1				
63	23-0677-7	Motor Cover 2 Speed						1		
64	02-0071-7	Fast Nut		3	3	3	3	3		
65	01-0068-5	Screw 8x3/8"		3	3	3	3	3	8	8
66	04-0144-8	Pressure Washer 5/16	4	4	4	4	4	4	8	8
67	01-1777-0	Screw (5/16-18 x 1 1/2 " )							8	8
67	01-1771-3	Screw (5/16-18 x 1 " )	4	4	4	4	4	4		
68	46-2231-2	Lever Sub Assembly		1	1	1	1	1		
68-A	12-0617-6	Lever Grip		1	1	1	1	1		
69	02-0119-4	Nut Acorn	1						1	1
69	05-3582-3	Washer		1	1	1	1	1		
70	06-0404-1	Tub Clamp	1	1	1	1	1	1	1	1
71	04-0073-9	Flat Washer 3/8"	1	1	1	1	1	1	1	1
72	06-0865-3	Knob butterflies	1						1	1
72	45-0451-0	Pressure Adjusting Nov Assembly		1	1	1	1	1		
73	06-0771-3	Tube Socket	1	1	1	1	1	1	1	1
74	25-0155-9	Socket Axle	1	1	1	1	1	1	1	1
75	04-0352-7	Lock Truarc 5103-50	2	2	2	2	2	2		
75	04-0585-2	Clamp Truarc							4	4
76	01-1012-2	Oppressor Allen (3/8-16x3/8 )	1	1	1	1	1	1		
77	04-0397-2	Washer							2	2
78	01-1704-4	Screw Hexagonal Heat ½-13x3	2	2	2	2	2	2		
79	45-0396-7	Wheel Assembly	2	2	2	2	2	2		
79	45-0573-1	Wheel Polisher							2	2
80	25-1210-1	Separator of the brace	2	2	2	2	2	2		
80	25-1291-1	Separator of the brace							2	2
81	05-1975-1	Tube	2	2	2	2	2	2		
81	05-4304-1	Tube							2	2
82	04-0074-7	Flat Washer	2	2	2	2	2	2	4	4
83	01-1746-5	Screw (3/8-16x5 )	1						1	1
84	06-0843-0	Polisher Base 13"	1							
84	06-0732-5	Polisher Base		1	1	1	1	1		
84	46-2995-2	Polisher Base 17 "							1	
84	46-2996-0	Polisher Base 20"								1
84-A	13-2626-3	Chassis 17"							1	
84-A	13-2627-1	Chassis 20"								1
84-B	25-1314-1	Axis Grooved for Wheel							1	1
84-C	26-0229-0	Bushing Axis Yoke							2	2
84-D	05-2330-0	Separating Motor Fixation							8	8
85	12-0667-1	Molding chassis 13 "	1							
85	46-2540-6	Assembly. Plate 17 "		1						
85	46-2541-4	Assembly. Plate 20 "				1	1			
85-A	23-0663-7	Assembly Black plate 17 "		1	1					
85-A	23-0664-5	Assembly Black plate 20 "				1	1	1		
85-B	12-0807-3	17" Plate Gasket		1	1					
85-B	12-0808-1	20" Plate Gasket				1	1	1		
86	03-0119-2	U Type Rivet	2	2	2	2	2	2		
87	17-3550-5	WARNING Plate	1	1	1	1	1	1		
88	04-0545-6	Washer Stainless Steel							2	2
89	04-0078-8	Flat Washer		5	5	5	5	5		
90	01-1775-4	Screw Hexagonal Heat ¼-20x3/4		5	5	5	5	5		
91	17-3025-8	KOBLLENZ Label	1	1	1	1	1	1	1	1