

This Owner's Manual is provided and hosted by [Appliance Factory Parts](#).

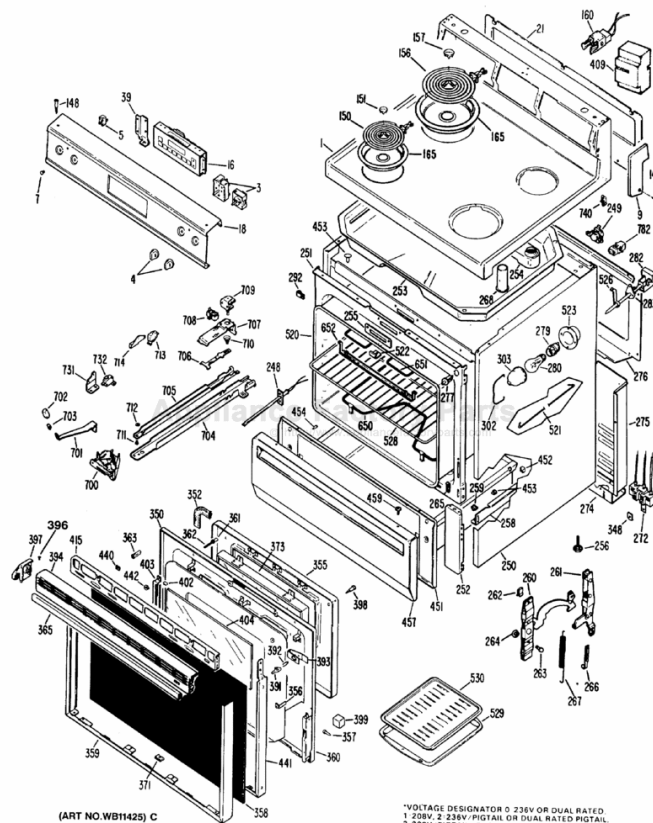

GE JB450G*P1 Owner's Manual

[Shop genuine replacement parts for GE JB450G*P1](#)



[Find Your GE Electric Range Parts - Select From 348 Models](#)

----- Manual continues below -----



Use and Care & Installation Guide

Self-Cleaning Electric Range

Contents

Aluminum Foil	20	Power Outage?	9
Anti-Tip Device	3,30,32	Problem Solver	28, 29
Appliance Registration	2	Safety Instructions	2-4
Canning Tips	11	Set the Clock	9
Care and Cleaning	25-27	Set the Timer	9
Clock/Timer	8, 9	Surface Cooking	10-13
Consumer Services	35	Control Settings	10
Energy-Saving Tips	5	Cookware Tips	12,13
Features	6,7	Surface Light	14
Installation Instructions	30-32	Surface Light Replacement	26
Leveling	5	3-in-1 Burners	10
Model and Serial Numbers	2	Warranty	Back Cover
Oven	14-25		
Baking/Baking Guide	15-17		
Broiling/Broiling Guide	20,21		
Control Panel	8		
Control Settings	8,15-24		
Door Removal	25		
Light; Bulb Replacement	14,25		
Preheating	5,17		
Roasting/Roasting Guide	18, 19		
Self-Cleaning Instructions	22-24		
Thermostat Adjustment	24	GE Answer Center®	
Vent Duct	25	80(7.626.2000)	

**Models JB450GP
JB550GP
JB551GP**

GE Appliances

Help us help you...

Before using your range, read this book carefully.

It is intended to help you operate and maintain your new range properly.

Keep it handy for answers to your questions.

If you don't understand something or need more help, write (include your phone number):

Consumer Affairs
GE Appliances
Appliance Park
Louisville, KY 40225

Write down the model and serial numbers.

You'll find them on a label on the front of the range behind the oven door.

These numbers are also on the Consumer Product Ownership Registration Card that came with your range. Before sending in this card, please write these numbers here:

Model Number

Serial Number

Use these numbers in any correspondence or service calls concerning your range.

If you received a damaged range...

Immediately contact the dealer (or builder) that sold you the range.

Save time and money. Before you request service...

Check the Problem Solver in the back of this book. It lists causes of minor operating problems that you can correct yourself.

If you need service...

To obtain service, see the Consumer Services page in the back of this book.

We're proud of our service and want you to be pleased. If for some reason you are not happy with the service you receive, here are three steps to follow for further help.

FIRST, contact the people who serviced your appliance. Explain why you are not pleased. In most cases, this will solve the problem.

NEXT, if you are still not pleased, write all the details—including your phone number—to:

Manager, Consumer Relations
GE Appliances
Appliance Park
Louisville, KY 40225

FINALLY, if your problem is still not resolved, write:

Major Appliance Consumer
Action Panel
20 North Wacker Drive
Chicago, IL 60606

IMPORTANT SAFETY INSTRUCTIONS

Read all instructions before using this appliance.

IMPORTANT SAFETY NOTICE

The California Safe Drinking Water and Toxic Enforcement Act requires the Governor of California to publish a list of substances known to the state to cause birth defects or other reproductive harm, and requires businesses to warn customers of potential exposure to such substances.

The fiberglass insulation in self-clean ovens gives off a very small amount of carbon monoxide during the cleaning cycle. Exposure can be minimized by venting with an open window or using a ventilation fan or hood.

IMPORTANT SAFETY INSTRUCTIONS

Read all instructions before using this appliance.

When using electrical appliances, basic safety precautions should be followed, including the following:

- Use this appliance only for its intended use as described in this manual.

- Be sure your appliance is properly installed and grounded by a qualified technician in accordance with the provided installation instructions.

- Don't attempt to repair or replace any part of your range unless it is specifically recommended in this book. All other servicing should be referred to a qualified technician.

- Before performing any service, DISCONNECT THE RANGE POWER SUPPLY AT THE HOUSEHOLD DISTRIBUTION PANEL BY REMOVING THE FUSE OR SWITCHING OFF THE CIRCUIT BREAKER.

WARNING—All ranges

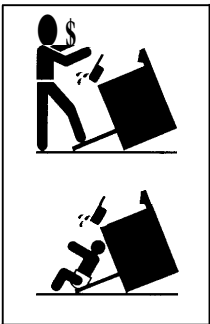

can tip and injury could result. To prevent accidental tipping of the range, attach it to the wall and floor by installing the Anti-Tip

device supplied. (See Installation Instructions.) To check if the device is installed and engaged properly, carefully tip the range forward until it engages the device.

If you pull the range out from the wall for any reason, make sure the device engages the range when you push the range back.

- Do not leave children alone—children should not be left alone or unattended in an area where an appliance is in use. They should never be allowed to sit or stand on any part of the appliance.

- Don't allow anyone to climb, stand or hang on the door, drawer or range top. They could damage the range and even tip it over, causing severe personal injury.

- **CAUTION: ITEMS OF INTEREST TO CHILDREN SHOULD NOT BE STORED IN CABINETS ABOVE A RANGE OR ON THE BACKSPASH OF A RANGE—CHILDREN CLIMBING ON THE RANGE TO REACH ITEMS COULD BE SERIOUSLY INJURED.**

- Never wear loose-fitting or hanging garments while using the appliance. Flammable material could be ignited if brought in contact with hot heating elements and may cause severe burns.

- Use only dry pot holders—moist or damp pot holders on hot surfaces may result in burns from steam. Do not let pot holders touch hot heating elements. Do not use a towel or other bulky cloth.

- For your safety, never use your appliance for warming or heating the room.

- Do not store flammable materials in an oven or near the cooktop.

- **DO NOT STORE OR USE COMBUSTIBLE MATERIALS, GASOLINE OR OTHER FLAMMABLE VAPORS AND LIQUIDS IN THE VICINITY OF THIS OR ANY OTHER APPLIANCE.**

- Keep hood and grease filters clean to maintain good venting and to avoid grease fires.

- Do not let cooking grease or other flammable materials accumulate in or near the range.

- Do not use water on grease fires. Never pick up a flaming pan. Smother flaming pan on surface unit by covering pan completely with well-fitting lid, cookie sheet or flat tray. Flaming grease outside a pan can be put out by covering with baking soda or, if available, a multi-purpose dry chemical or foam type fire extinguisher.

- Do not touch heating elements or interior surface of oven. These surfaces may be hot enough to burn even though they are dark in color. During and after use, do not touch, or let clothing or other flammable materials contact surface units, areas nearby surface units or any interior area of the oven; allow sufficient time for cooling, first.

Potentially hot surfaces include the cooktop and areas facing the cooktop, oven vent opening and surfaces near the opening, and crevices around the oven door. Remember: The inside surface of the oven may be hot when the door is opened.

- When cooking pork, follow the directions exactly and always cook the meat to an internal temperature of at least 170°F. This assures that, in the remote possibility that trichina may be present in the meat, it will be killed and the meat will be safe to eat.

(continued on next page)

IMPORTANT SAFETY INSTRUCTIONS (continued)

Oven

• **Stand away from range when opening oven door. Hot air or steam which escapes can cause burns to hands, face and/or eyes.**

• **Don't heat unopened food containers in the oven. Pressure could build up and the container could burst, causing an injury.**

• **Keep oven vent duct unobstructed.**

• **Keep oven free from grease buildup.**

• **Place oven shelf in desired position while oven is cool. If shelves must be handled when hot, do not let pot holder contact heating units in the oven.**

• **Pulling out shelf to the shelf stop is a convenience in lifting heavy foods. It is also a precaution against burns from touching hot surfaces of the door or oven walls.**

• **When using cooking or roasting bags in oven, follow the manufacturer's directions.**

• **Do not use your oven to dry newspapers. If overheated, they can catch fire.**

• **Do not use oven for a storage area. Items stored in an oven can ignite.**

Self-Cleaning Oven

• **Do not clean door gasket.** The door gasket is essential for a good seal. Care should be taken not to rub, damage or move the gasket.

• **Do not use oven cleaners.** No commercial oven cleaner or oven liner protective coating of any kind should be used in or around any part of the oven.

• **Clean only parts listed in this Use and Care Book.**

• **Before self-cleaning the oven, remove broiler pan and other cookware.**

Surface Cooking Units

• **Use proper pan size**—This appliance is equipped with one or more surface units of different size. Select cookware having flat bottoms large enough to cover the surface unit heating element. The use of undersized cookware will expose a portion of the heating element to direct contact and may result in ignition of clothing. Proper relationship of cookware to burner will also improve efficiency.

• **Never leave surface units unattended at high heat settings.** Boilover causes smoking and greasy spillovers that may catch on fire.

• **Be sure drip pans and vent ducts are not covered and are in place.** Their absence during cooking could damage range parts and wiring.

• **Don't use aluminum foil to line drip pans** or anywhere in the oven except as described in this book. Misuse could result in a shock, fire hazard or damage to the range.

• **Only certain types of glass, glass/ceramic, earthenware or other glazed containers are suitable for range-top service;** others may break because of the sudden change in temperature. (See section on "Surface Cooking" for suggestions.)

• **To minimize the possibility of burns, ignition of flammable materials, and spillage, the handle of a container should be turned toward the center of the range without extending over nearby surface units.**

• **Always turn surface unit to OFF before removing cookware.**

• **Keep an eye on foods being fried at HI or MED HI heat settings.**

• **To avoid the possibility of a burn or electric shock, always be certain that the controls for all surface units are at OFF position and all coils are cool before attempting to lift or remove the unit.**

• **Don't immerse or soak removable surface units. Don't put them in a dishwasher. Do not self-clean the surface units in the oven.**

• **When flaming foods are under the hood, turn the fan off. The fan, if operating, may spread the flame.**

• **Foods for frying should be as dry as possible.** Frost on frozen foods or moisture on fresh foods can cause hot fat to bubble up and over sides of pan.

• **Use little fat for effective shallow or deep-fat frying.** Filling the pan too full of fat can cause spillovers when food is added.

• **If a combination of oils or fats will be used in frying,** stir together before heating. Oil as fats melt slowly.

• **Always heat fat slowly, and watch as it heats.**

• **Use deep fat thermometer whenever possible** to prevent overheating fat beyond the smoking point.

SAVE THESE INSTRUCTIONS

Installing Your Range

Your range, like many other household items, is heavy and can settle into soft floor coverings such as cushioned vinyl or carpeting. When moving the range on this type of flooring, use care, and it is recommended that these simple and inexpensive instructions be followed.

The range should be installed on a 1/4-inch-thick sheet of plywood (or similar material) as follows: *When the floor covering ends at the front of the range*, the area that the range will rest on should be built up with plywood to the same level or higher than the floor covering. This will allow the range to be removed for cleaning or servicing. For complete information, see the Installation Instructions in the back of this book.

Leveling the Range

Leveling screws are located on each corner of the base of the range. Remove the bottom drawer and you can level the range on an uneven floor with the use of a nutdriver.

To remove drawer, pull drawer out **all the way**, tilt up the front and **take it out**. To replace drawer, insert glides at back of drawer beyond stop on range glides. Lift drawer if necessary to insert easily. Let front of drawer down, then push in to close.

One **of** the rear leveling screws will engage the Anti-Tip device (allow for some side to side adjustment). Allow a minimum clearance of 1/8" between the range and the leveling screw that is to be installed into the Anti-Tip device.

Energy-Saving Tips

Surface Cooking

- Use cookware of medium-weight aluminum, with tight-fitting covers, and flat bottoms which completely cover the heated portion of the surface unit.

- Cook fresh vegetables with a minimum amount of water in a covered pan.

- Watch foods when bringing them quickly to cooking temperatures at high heat. When food reaches cooking temperature, reduce heat immediately to lowest setting that will keep it cooking.

- Use residual heat with surface cooking whenever possible. For example, when cooking eggs in their shells, bring water and eggs to a boil, then turn control knob to OFF position and cover cookware with lid to complete the cooking.

- Use correct heat setting for cooking task:

HI—to start cooking (if time allows, do not use high heat to start).

MEDIUM HI—for quick browning.

MED—for slow frying.

WARM—to finish cooking most quantities, simmer-double boiler heat, and special for small quantities.

LO—to maintain serving temperature of most foods.

- When boiling water for tea or coffee, heat only amount needed. It is not economical to boil a container full of water for one or two CLIPS.

Oven Cooking

- Preheat oven only when necessary. Most foods will cook satisfactorily without preheating. If you find preheating is necessary, watch the electronic oven display, and put food in oven promptly after the selected temperature is displayed and the oven signals.

- Always turn oven off before removing food.

- During baking, avoid frequent door openings. Keep door open as short a time as possible if it is opened,

- Be sure to wipe up excess spillage before starting the self-cleaning operation.

- Cook complete oven meals instead of just one food item. Potatoes, other vegetables, and some desserts will cook together with a main-dish casserole, meat loaf, chicken or roast. Choose foods that cook at the same temperature and in approximately the same amount of time.

- Use residual heat in the oven whenever possible to finish cooking casseroles, oven meals, etc. Also add rolls or precooked desserts to a warm oven, using residual heat to warm them.

Features of Your Range

JB450GP
JB550GP
JB551GP

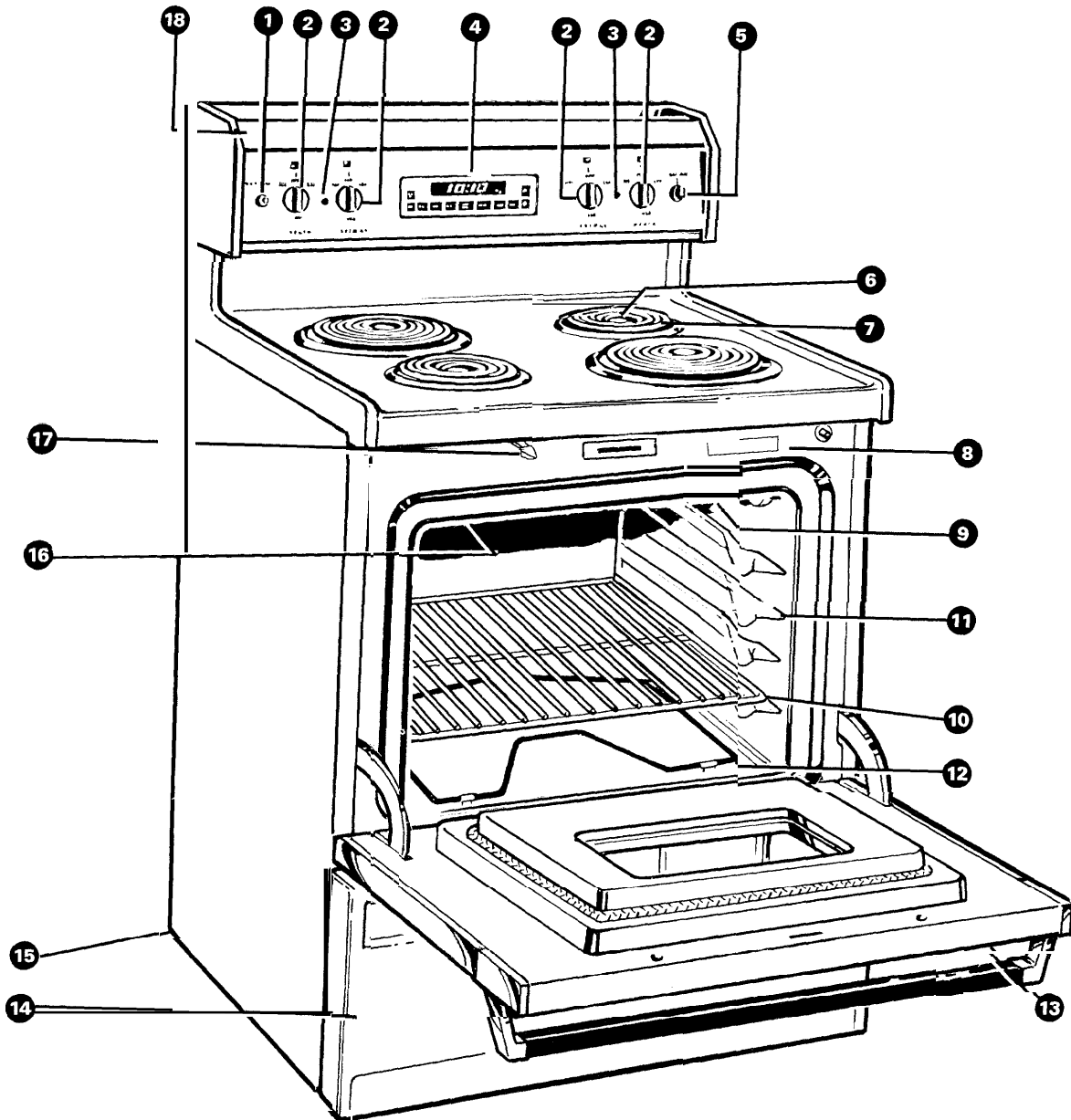
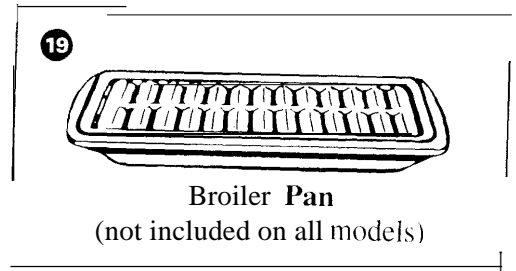

(Note: not all doors have windows)

Feature Index (not all models will have all features)	Explained on page
1 Surface Light Switch (on models so equipped)	14
2 Surface Unit Controls	10
3 Surface Unit "ON" Indicator Light	10
4 Oven Control, Clock and Timer	8-9
5 3-in-1 Surface Unit Control (on models so equipped)	10
6 Oven Vent Duct (Located under right rear surface unit.)	25
7 Calrod® Surface Unit, Trim Rings/Drip Pans (on models so equipped)	10, 26
8 Model and Serial Numbers	2
9 Oven Interior Light (Comes on automatically when door is opened.) (on models so equipped)	14,25
10 Oven Shelf (number may vary)	14,22, 27
11 Oven Shelf Supports	14
12 Bake Unit (May be lifted gently for wiping oven floor.)	15, 27
13 Oven Light Switch (for models with oven window)	14
14 Storage Drawer (on models so equipped)	25, 27
15 Anti-Tip Device (See Installation Instructions.)	3,5,30,32
16 Broil Unit	20, 27
17 Door Latch (Use for Self-Clean only.)	22,23
18 Surface Light (on models so equipped)	14, 26
19 Broiler Pan and Rack (Do not clean in Self-Clean oven.) (on models so equipped)	20, 21, 27

Features of Your Oven Control



1. **INCREASE.** Short taps to this pad increase time or temperature by small amounts. Press & hold pad to increase time or temperature by larger amounts.

2. **DECREASE.** Short taps to this pad decrease time or temperature by small amounts. Press & hold pad to decrease time or temperature by larger amounts.

3. **BAKE.** Touch this pad to select bake function. Then tap or press INCREASE or DECREASE pad to display desired temperature.

4. **BROIL.** Touch this pad to select broil function. Then tap INCREASE pad once to broil at LO (450°F.) or twice to broil at HI (550°F.). Tap DECREASE pad to change back to LO broil.

5. **CLEAN.** Touch this pad to select self-cleaning function. See Self-Cleaning Instructions.

6. **COOK TIME.** Touch this pad and then touch the INCREASE or DECREASE pad to set the amount of time you want your food to cook. Touch BAKE and the INCREASE or DECREASE pad to set the oven temperature. The oven will shut off after the selected Cook Time has run out.

7. **STOP TIME.** Use this pad along with COOK TIME and INCREASE or DECREASE pad to set the oven to start automatically, cook for a specified time and stop automatically at a time you select.

8. **CLOCK.** Touch this pad before setting the clock.

To set clock, first touch CLOCK pad. "TIME" will flash in the display. Tap INCREASE or DECREASE pad to change the time of day by small amounts. Press & hold INCREASE or DECREASE pad to change the time of day by larger amounts.

9. **TIMER.** Touch this pad to select timer function. The timer does not control oven operations. The timer can time up to 9 hours and 55 minutes.

To set timer, first touch TIMER pad. "TIMER" will flash in the display. Tap INCREASE or DECREASE pad to change the time by small amounts. Press & hold INCREASE or DECREASE pad to change the time by larger amounts.

Hours and minutes will be displayed if the time set on the timer is more than 1 hour. Minutes and seconds will be displayed if the time set on the timer is less than 1 hour. Press & hold TIMER pad to clear timer.

10. **CLEAR/OFF.** Touch this pad to cancel all oven operations except clock and timer.

11. **PROGRAM STATUS.** Words light up in the display to indicate what is in time display.

Programmed information can be displayed at any time by touching the pad of the operation you want to see. For example, you can display the current time of day while the timer is counting down by touching the CLOCK pad.

12. **TIME DISPLAY.** Shows the time of day, the times set for the timer or automatic oven operation.

13. **OVEN TEMPERATURE AND BROIL DISPLAY.** Shows the oven temperature or the broil setting selected.

14. **FUNCTION INDICATORS.** Lights up to show whether oven is in bake, broil or self-clean mode.

Oven Control, Clock and Timer

Clock

The clock must be set for the automatic oven timing functions to work properly. The time of day cannot be changed during a TIME BAKE or CLEAN cycle.

To Set the Clock



Step 1. Touch the CLOCK pad.



Step 2. Press INCREASE or DECREASE pad to set the time of day.

Step 3. Touch the CLOCK pad to start.

Power Outage?

After a power outage, when power is restored the display will flash and time shown will no longer be correct—for example, after a 5-minute power interruption the clock will be 5 minutes slow. The display flashes until the clock is reset. All other functions that were in operation when the power went out will have to be programmed again.

Timer

The timer does not control oven operations. The maximum setting on the timer is 9 hours and 55 minutes.

To Set The Timer

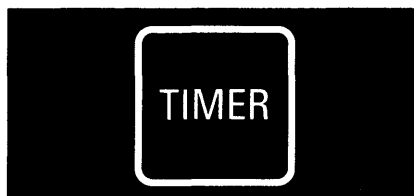

Step 1. Touch the TIMER pad.

Step 2. Press INCREASE or DECREASE pad to set the amount of time on timer.

The timer will start automatically within a few seconds of releasing the pad.

The timer, as you are setting it, will display seconds until 60 seconds is reached.

Then it will display minutes and seconds until 60 minutes is reached.

After 60 minutes, it will display hours (“HR” now appears in display) and minutes until the maximum time of 9 hours and 55 minutes is reached.

To Reset Timer

Touch TIMER pad and then press INCREASE or DECREASE pad until the time you want shows on the display.

To Cancel Timer

Press TIMER pad until the word “TIMER” quits flashing on the display (about 4 seconds).

Timer Tones

The timer tone is a steady signal that repeats every 6 seconds until you touch any operation. If you would like to change the tone to a set of 3 short beeps, press & hold CLEAWOFF for 10 seconds.

To return the timer tone to a steady repeating signal, press & hold CLEAWOFF for 10 seconds.

Display Messages

If “door” appears on the display, the oven door is in the locked position. BAKE, BROIL and COOK TIME cannot be set if the door is in the locked position.

If “F” and a number flash on display, this indicates function error code. If function error code appears during the self-cleaning function, check oven door latch—the latch handle may have been moved, even if only slightly, from the latched position. Make sure handle is to the right as far as it will go. Touch CLEAWOFF pad. If function error code does not clear, disconnect power to the range and call for service.

Surface Cooking

See Surface Cooking Guide.

Surface Cooking with Infinite Heat Controls

Your surface units and controls are designed to give you an infinite choice of heat settings for surface unit cooking.

At both OFF and HI positions, there is a slight niche so control “clicks” at those positions; “click” on HI marks the highest setting; the lowest setting is between the words LO and OFF. In a quiet kitchen you may hear slight “clicking” sounds during cooking, indicating heat settings selected are being maintained.

Switching heats to higher settings always shows a quicker change than switching to lower settings.

How to Set the Controls

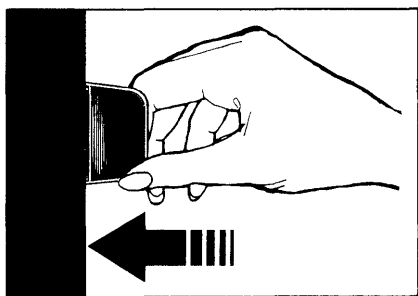

Step 1

Grasp control knob and push in.

Step 2

Turn either clockwise or counter-clockwise to desired heat setting.

Control must be pushed in to set only from OFF position. When control is in any position other than OFF, it may be rotated without pushing in.

Be sure you turn control to OFF when you finish cooking. An indicator light will glow when ANY heat on any surface unit is on.

Cooking Guide for Using Heat Settings

(Appearance may vary slightly)

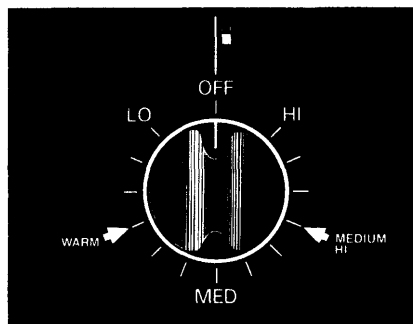

HI—Quick start for cooking; brings water to a boil.

MEDIUM HI—(Setting halfway between HI and MED) Fast fry, pan broil; maintains a fast boil on large amounts of food.

MED—Saute and brown; maintains a slow boil on large amounts of food.

WARM—(Setting halfway between MED and LO) Cook after starting at HI; cooks with little water in covered pan.

LO—Steam rice, cereal; maintains serving temperature of most foods.

NOTE:

1. At HI, MEDIUM HI settings, never leave food unattended. Boilovers cause smoking; greasy spillovers may catch fire.
2. At WARM, LO settings, melt chocolate and butter on small surface unit.

How to Use the 3-in-1 Unit (on models so equipped)

This surface unit offers the convenience of three units in one. The unit may be used as an 8-inch, 6-inch, or 4-inch unit to accommodate any size cookware. Turn size selector switch, next to surface unit control, to 8", 6" or 4." Then turn surface unit control to desired heat setting.

Match unit size selection to size of cookware.

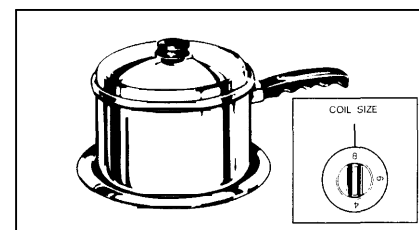

LARGE—8-inch unit. Turn switch to 8" when using large cookware that completely cover the unit (3-quart to 6-quart saucepans or 8- to 10-inch skillet). Then select desired heat setting.

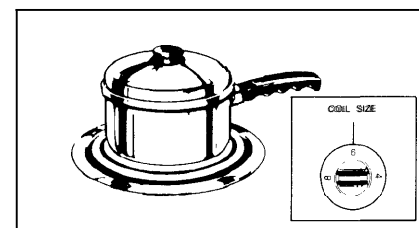

MEDIUM—6-inch unit. Turn switch to 6" when using medium-sized cookware that do not completely cover the unit (2- to 2 1/2-quart saucepans or 6- to 7-inch skillets). Then select desired heat setting.

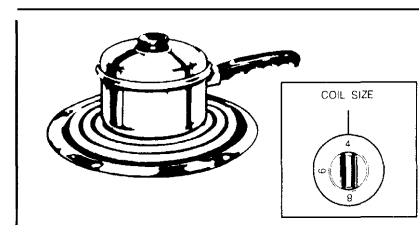

SMALL—4-inch unit. Turn switch to 4" when using small cookware about 4 inches in diameter (as a 1-quart saucepan). Then select desired heat setting.

Questions & Answers

Q. May I can foods and preserves on my surface units?

A. Yes, but only use cookware designed for canning purposes. Check the manufacturer's instructions and recipes for preserving foods. Be sure canner is flat-bottomed and fits over the center of your Calrod® unit. Since canning generates large amounts of steam, be careful to avoid burns from steam or heat. Canning should only be done on surface units.

Q. Can I cover my drip pans with foil?

A. No. Clean as recommended in Cleaning Guide.

Q. Can I use special cooking equipment, like an oriental wok, on any surface units?

A. Cookware without flat surfaces is not recommended. The life of your surface unit can be shortened and the range top can be damaged from the high heat needed for this type of cooking.

Q. Why am I not getting the heat I need from my units even though I have the knobs on the right setting?

A. After turning surface unit off and making sure it is cool, check to make sure that your plug-in units are securely fastened into the surface connection.

Q. Why does my cookware tilt when I place it on the surface unit?

A. Because the surface unit is not flat. Make sure that the "feet" on your Calrod® units are sitting tightly in the range top indentation and the reflector ring is flat on the range surface.

Q. Why is the porcelain finish on my cookware coming off?

A. If you set your Calrod® unit higher than required for the cookware material, and leave it, the finish may smoke, crack, pop, or burn depending on the pot or pan. Also, a too high heat for long periods, and small amounts of dry food, may damage the finish.

Home Canning Tips

Canning should be done on surface units only.

Pots that extend beyond 1 inch of surface unit's trim ring are not recommended for most surface cooking. However, when canning with water-bath or pressure canner, larger-diameter pots may be used. This is because boiling water temperatures (even under pressure) are not harmful to cooktop surfaces surrounding the surface unit.

HOWEVER, DO NOT USE LARGE DIAMETER CANNERS OR OTHER LARGE DIAMETER POTS FOR FRYING OR BOILING FOODS OTHER THAN WATER.

Most syrup or sauce mixtures—and all types of frying—cook at temperatures much higher than boiling water. Such temperatures could eventually harm cooktop surfaces surrounding surface units.

Observe Following Points in Canning

1. Be sure the canner fits over the center of the surface unit. If your range or its location does not allow the canner to be centered on the surface unit, use smaller diameter pots for good canning results.
2. Flat-bottomed canners must be used. Do not use canners with flanged or rippled bottoms (often found in enamelware) because they don't make enough contact with the surface unit and take too long to boil water.

RIGHT



WRONG

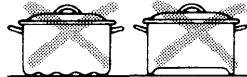

3. When canning, use recipes and procedures from reputable sources. Reliable recipes and procedures are available from the manufacturer of your canner; manufacturers of glass jars for canning, such as Ball and Kerr; and the United States Department of Agriculture Extension Service.

4. Remember that canning is a process that generates large amounts of steam. To avoid burns from steam or heat, be careful when canning.

NOTE: If your range is being operated on low power (voltage), canning may take longer than expected, even though directions have been carefully followed. The process time will be shortened by: (1) using a pressure canner, and (2) starting with HOT tap water for fastest heating of large quantities of water.

Surface Cooking Guide

Control Settings

HI—Highest setting.

MEDIUM HI—Setting halfway between HI and MED.

MED—Medium setting.

WARM—Setting halfway between MED and LO.

LO—Lowest setting.

Cookware Tips

1. Use medium- or heavy-weight cookware. Aluminum cookware conducts heat faster than other metals. Cast iron and coated cast iron cookware are slow to absorb heat, but generally cook evenly at low to medium heat settings. Steel pans may cook unevenly if not combined with other metals.

Food	Cookware	Directions and Settings to Start Cooking	Directions and Settings to Complete Cooking	Comments	
Cereal Cornmeal, grits, oatmeal	Covered Saucepan	HI. In covered pan bring water to boil before adding cereal.	WARM or LO, then add cereal. Finish timing according to package direction.	Cereals bubble and expand as they cook; use large enough saucepan to prevent boilover.	
Cocoa	Uncovered Saucepan	HI. Stir together water or milk and cocoa ingredients. Bring just to a boil.	MED, to COOL 1 or 2 minutes to completely blend ingredients	Milk boils over rapidly. Watch as boiling point approaches.	
Coffee	Percolator	HI. At first perk, switch heat to WARM.	WARM to maintain gentle but steady perk.	Percolate 8 to 10 minutes for 8 cups, less for fewer cups.	
Eggs Cooked in shell	Covered Saucepan	HI. Cover eggs with COOL water. Cover pan, cook until steaming.	LO. Cook only 3 to 4 minutes for soft cooked; 15 minutes for hard cooked.	If you do not cover skillet, baste eggs with fat to cook tops evenly.	
Fried sunny-side-up	Covered Skillet	MEDIUM HI. Melt butter, add eggs and cover skillet.	Continue cooking at MEDIUM HI until whites are just set, about 3 to 5 more minutes.		
Fried over easy	Uncovered Skillet	HI. Melt butter.	WARM, then add eggs. When bottoms of eggs have just set, carefully turn over to cook other side.		
Pouched	Covered Saucepan	HI. In covered pan bring water to a boil.	WARM. Carefully acid eggs. Cook uncovered about 5 minutes at MEDIUM HI.		Remove cooked eggs 11 with slotted spoon or pancake turner.
Scrambled or omelets	Uncovered Skillet	HI. Heat butter until light golden in color.	MED. Add egg mixture. Cook, stirring to desired doneness.		Eggs continue to set slightly after cooking. For omelet do not stir last few minutes. When set, fold in half.
Fruits	Covered Saucepan	HI. In covered pan bring fruit and water to boil.	LO. Stir occasionally and check for sticking.	Fresh fruit: Use 1/4 to 1/2 cup water per pound of fruit. Dried fruit: Use water as package directs. Time depends on whether fruit has been presoaked. If not, allow more cooking time.	
Meats, Poultry Braised: Pot roasts of beef, lamb or veal; pork steaks and chops	Covered Skillet	HI. Melt fat, then add meat. Switch to MEDIUM HI to brown meat. Add water or other liquid.	WARM. Simmer until fork tender.	Meat can be seasoned and floured before it is browned, if desired. Liquid variations for "flavor" could be wine, fruit or tomato juice or meat broth. Timing: Steaks 1 to 2 inches. 1 to 2 hours, Beef Stew: 2 to 3 hours Pot Roast: 2 to 4 hours.	
Pan-fried: Tender chops; thin steaks up to 3/4-inch; minute steaks; hamburgers; franks and sausage; thin fish fillets	Uncovered Skillet	HI. Preheat skillet, then grease lightly.	MEDIUM HI or MED. Brown and cook to desired doneness, turning over as needed.	Pan frying is best for thin steaks and chops. If rare is desired, preheat skillet before adding meat.	

2. To conserve the most cooking energy, pans should be flat on the bottom, have straight sides and tight fitting lids. Match the size of the saucepan to the size of the surface unit. A pan that extends more than one inch beyond the edge of the trim ring will trap heat causing discoloration on chrome trim rings ranging from blue to dark grey.

3. Deep Fat Frying. Do not overfill cookware with fat that may spill over when adding food. Frosty foods bubble vigorously. Watch foods frying at high temperatures. Keep range and hood clean from accumulated grease.

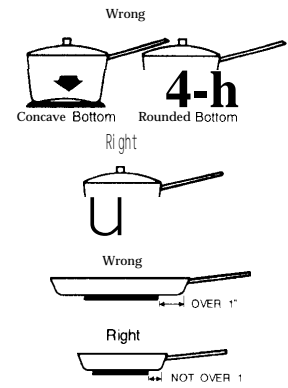

Food	Cookware	Directions and Settings to Start Cooking	Directions and Settings to Complete Cooking	Comments
Fried Chicken	Covered Skillet	HI. Melt fat. Switch to MED HI to brown chicken.	LO. Cover skillet and cook until tender. Uncover last few minutes.	For crisp, dry chicken, cover only after switching to LO for 10 minutes. Uncover and cook, turning occasionally for 10 to 20 minutes.
Pan-fried bacon	Uncovered Skillet	HI. In cold skillet, arrange bacon slices. Cook just until starting to sizzle.	MED HI. Cook, turning over as needed.	A more attention-free method is to start and cook at MED.
Sauteed: Less tender thin steaks (chuck, round, etc.); Liver; thick or whole fish	Covered Skillet	HI. Melt fat. Switch to MED to brown slowly.	LO. Cover and cook until tender.	Meat may be breaded or marinated in sauce before frying.
Simmered or stewed meat: chicken; corned beef; smoked pork; stewing beef; tongue; etc.	Covered Dutch Oven, Kettle or Large Saucepan	HI. Cover meat with water and cover pan or kettle. Cook until steaming.	LO. Cook until fork tender. (Water should boil slowly.) For very large amounts, medium heat may be needed.	Add salt or other seasoning before cooking if meat has not been smoked or otherwise cured.
Melting chocolate, butter, marshmallow	Small Uncovered Saucepan. Use small surface unit	WARM. Allow 10 to 15 minutes to melt through. Stir to smooth.		When melting marshmallows, add milk or water.
Pancakes or French toast	Skillet or Griddle	MED HI. Heat skillet 8 to 10 minutes. Grease lightly.	Cook 2 to 3 minutes per side.	Thick batter takes slightly longer time. Turn over pancakes when bubbles rise to surface.
Pasta Noodle or spaghetti	Large Covered Kettle or Pot	HI. In covered kettle, bring salted water to a boil, uncover and add pasta slowly so boiling does not stop.	MED HI. Cook uncovered until tender. For large amounts, HI may be needed to keep water at rolling boil throughout entire cooking time.	Use large enough kettle to prevent boilover. Pasta doubles in size when cooked.
Pressure Cooking	Pressure Cooker or Canner	HI. Heat until first jiggle is heard.	MED HI for foods cooking 10 minutes or less. MED for foods over 10 minutes.	Cooker should jiggle 2 to 3 times per minute.
Puddings, Sauces, Candies, Frostings	Uncovered Saucepan	HI. Bring just to boil.	LO. To finish cooking,	Stir frequently to prevent sticking.
Vegetables Fresh	Covered Saucepan	HI. Measure 1/2 to 1 inch water in saucepan. Add salt and prepared vegetable. In covered saucepan bring to boil.	MED. Cook 1 pound 10 to 30 or more minutes, depending on tenderness of vegetable.	Uncovered pan requires more water and longer time.
Frozen	Covered Saucepan	HI. Measure water and salt as above. Add frozen block of vegetable. In covered saucepan bring to boil.	LO. Cook according to time on package.	Break up or stir as needed while cooking.
Sauteed: Onions; green peppers; mushrooms; celery; etc.	Uncovered Skillet	HI. In skillet, melt fat.	MED. Add vegetable. Cook until desired tenderness is reached.	Turn over or stir vegetable as necessary for even browning.
Rice and Grits	Covered Saucepan	HI. Bring salted water to a boil.	WARM. Cover and cook according to time.	Rice and grits triple in volume after cooking. Time at WARM. Rice: 1 cup rice and 2 cups water for 25 minutes. Grits: 1 cup grits and 4 cups water for 40 minutes.

Using Your Oven

Before Using Your Oven

1. Look at the controls. Be sure you understand how to set them properly. Read over the directions for the Electronic Controls so you understand how to use them.
2. Check oven interior. Look at the shelves. Take a practice run at removing and replacing them properly, to give sure, sturdy support.
3. Read over information and tips that follow.
4. Keep this book handy so you can refer to it, especially during the first weeks of getting acquainted with your range.

Oven Shelves

The shelves are designed with stop-locks so that when placed correctly on the shelf supports, they (a) will stop before coming completely from the oven, and (b) will not tilt when removing food from or placing food on them.

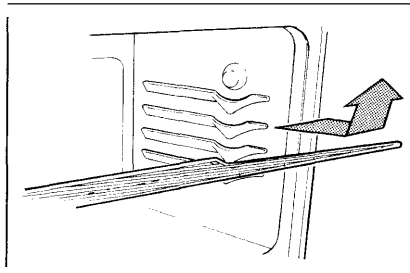

TO REMOVE THE SHELVES from the oven, pull them toward you, tilt front end upward and pull them out.

TO REPLACE, place shelf on shelf support with stop-locks (curved extension under shelf) facing up toward the rear of the oven. Tilt up front and push the shelf toward the back of the oven until it goes past “stop” on the oven wall. Then lower the front of the shelf and push it all the way back.

Shelf Positions

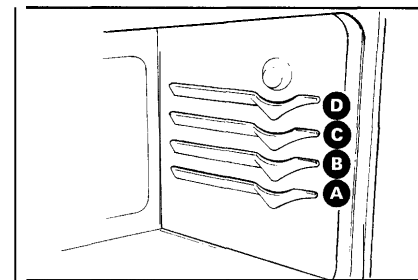

The oven has four shelf supports—A (bottom), B, C and D (top). Shelf positions for cooking food are suggested on Baking, Roasting and Broiling pages.

Oven Light

The light comes on automatically when the oven door is opened. Use the switch on front of door to turn the light on and off when the door is closed.

Lamp over Surface Unit (on models so equipped)

Push and hold switch until light comes on.

NOTE: Light will not come on as long as switch is held. Switch must be pushed, held for several seconds, and released for light to come on.

Baking

See Baking Guide.

Your oven temperature is controlled very accurately using an electronic control system. We recommend that you operate the range for a number of weeks using the time given on recipes as a guide to become familiar with your new oven's performance. If you think an adjustment is necessary, see Adjusting Oven Temperature section.

How to Set Your Range for Baking

Step 1: Position the shelf or shelves in the oven. If cooking on two shelves at the same time, place shelves on alternate shelf supports and stagger food on them.

Step 2: Close the oven door.



Step 3: Touch BAKE pad.



Step 4: Touch INCREASE pad. The last oven set temperature appears in the display.

Step 5: Press INCREASE or DECREASE pad until desired temperature is displayed.

The word "ON" and the changing temperature will be displayed as the oven heats up. When the oven reaches the set temperature a tone will sound.

To change oven temperature during BAKE cycle, touch BAKE pad and then INCREASE or DECREASE pad to get new temperature.



Step 6: Touch CLEAR/OFF when baking is finished and then remove food from oven.

How to Time Bake

The electronic oven control allows you to turn the oven on or off automatically at specific times that you set. **NOTE:** Before beginning make sure the oven clock shows the correct time of day.

To set the clock, first touch the CLOCK pad. "TIME" will flash in the display. Press INCREASE or DECREASE pad until correct time of day is displayed.

How to Set Immediate Start and Automatic Stop.

(Oven turns on right away, cooks for preset length of time, and turns off automatically at the preset Stop Time.)

Step 1: Position the shelf or shelves in the oven. If cooking on two shelves at the same time, place shelves on alternate shelf supports and stagger food on them.

Step 2: Close the oven door.



Step 3: Touch COOK TIME pad.



Step 4: Press INCREASE pad until the desired length of baking time appears in the display.



Step 5: Touch BAKE pad. Attention tone will occur if step 5 is not done.



Step 6: Press INCREASE or DECREASE pad until desired temperature is displayed.

The word "ON" and the rising oven temperature will be displayed as the oven heats up. When the oven reaches the set temperature a tone will sound. The oven will continue to cook for the programmed amount of time, then shut off automatically.

Step 7: Remove food from the oven. Remember, even though oven shuts off automatically, foods continue cooking after controls are off.

Baking (continued)

How to Set Delay Start and Stop

Quick Reminder:

1. Touch COOK TIME pad.
2. Touch INCREASE/DECREASE pad to set cooking time.
3. Touch STOP TIME pad.
4. Touch INCREASE/DECREASE pad until desired Stop Time appears in display.
5. Touch BAKE pad.
6. Touch INCREASE/DECREASE pad to select oven temperature.

Delay Start and Stop is setting the oven timer to turn the oven on and off automatically at a later time than the present time of day.

For example: Let's say it's 2:00 and dinner time is shortly after 7:00. The recipe suggests 3 hours baking time at 325°F. Here's how:

Step 1: Position the shelf or shelves in the oven. If cooking on two shelves at the same time, stagger the pans for best heat circulation.

Step 2: Close the oven door.



Step 3: Touch COOK TIME pad.



Step 4: For 3 hours of cooking time, press INCREASE pad until "3:00" appears in the display.



Step 5: Touch STOP TIME pad.



"5:00" appears on the display and "STOP TIME" flashes. The control automatically sets Stop Time by adding the Cook Time to the time of day. In this example, the time of day is 2:00 and the Cook Time is 3 hours. Adding 3 hours to the time of day equals 5:00.

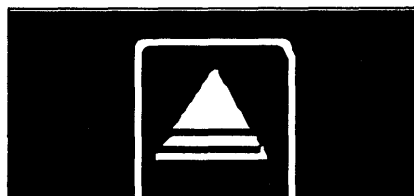

Step 6: Change Stop Time from 5:00 to 7:00 by pressing INCREASE pad until "7:00" appears in the display.



Step 7: Touch BAKE pad.

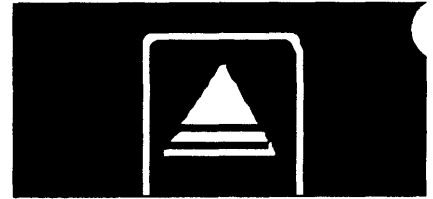

Step 8: Touch INCREASE pad. The last oven set temperature appears in the display. Press INCREASE or DECREASE pad until "325°" is displayed.

At 4:00, the oven will turn on automatically. The word "ON" and the changing oven temperature will be displayed as the oven heats up. The oven will continue to cook for the programmed 3 hours and shut off automatically at 7:00.

Step 9: Remove food from the oven. Remember, even though oven shuts off automatically, foods continue cooking after controls are off.

Note: The low temperature zone of this range (between 150°F and 200°F.) is available to keep hot cooked foods warm. Food kept in the oven longer than two hours at these low temperatures may spoil.

When setting your oven for a delay start, never let foods such as dairy products, fish, meat, poultry, etc. sit for more than 2 hours before actual cooking begins. Room temperature promotes the growth of harmful bacteria. Be sure the oven light is off because heat from the bulb will speed bacteria growth.

Baking Guide

1. Aluminum pans conduct heat quickly. For most conventional baking, light, shiny finishes give best results because they help prevent overbrowning. For best results, we recommend dull bottom surfaces for cake pans and pie plates.

2. Dark or non-shiny finishes and glass cookware generally absorb heat, which may result in dry, crisp crusts. Reduce oven heat 25°F. if lighter crusts are desired. Rapid browning of some foods can be achieved by preheating cast iron cookware.

3. Preheating the oven is not always necessary, especially for foods which cook longer than 30 to 40 minutes. For foods with short cooking times, preheating gives best appearance and crispness.

4. Open the oven door to check food as little as possible to prevent uneven heating and to save energy.

Food	Container	Shelf Position	Oven Temperature	Time, Minutes	Comments
Bread Biscuits (½-in.thick)	Shiny Cookie Sheet	B, C	400°-475°	15-20	Canned, refrigerated biscuits take 2 to 4 minutes less time.
coffee cake	Shiny Metal Pan with satin-finish bottom	B, A	350°-400°	20-30	
Corn bread or muffins	Cast Iron or Glass Pan	B	400°-450°	20-40	Preheat cast iron pan for crisp crust.
Gingerbread	Shiny Metal Pan with satin-finish bottom	B	350°	45-55	
Muffins	Shiny Metal Muffin Pans	A, B	400°-425°	20-30	Decrease about 5 minutes for muffin mix, or bake at 450°F. for 25 minutes, then at 350°F. for 10 to 15 minutes.
Popovers	Deep Glass or Cast Iron Cups	B	375°	45-60	
Quick loaf bread	Metal or Glass Loaf Pans	B	350°-375°	45-60	
Yeast bread (2 loaves)	Metal or Glass Loaf Pans	A, B	375°-425°	45-60	Dark metal or glass give deepest browning.
Plain rolls	Shiny Oblong or Muffin Pans	A, B	375°-425°	10-25	For thin rolls, Shelf B may be used.
Sweet rolls	Shiny Oblong or Muffin pans	B, A	350°-375°	20-30	
Cakes (without shortening)					
Angel food	Aluminum Tube Pan	A	325°-375°	30-55	Two-piece pan is convenient.
Jelly roll	Metal Jelly Roll Pan	B	375°-400°	10-15	Line pan with wax paper.
Sponge	Metal or Ceramic Pan	A	325°-350°	45-60	
Cakes					
Bundt cakes	Metal or Ceramic Pan	A, B	325°-350°	45-65	
Cupcakes	Shiny Metal Muffin Pans		350°-375°	20-25	Paper liners produce moister crusts.
Fruit cakes	Metal or Glass Loaf or Tube Pan	A ^B	275°-300°	2-4 hrs.	Use 300°F. and Shelf B for small or individual cakes.
Layer	Shiny Metal Pan with satin-finish bottom	B	350°-375°	20-35	
Layer, chocolate	Shiny Metal Pan with satin-finish bottom	B	350°-375°	25-30	
Loaf	Metal or Glass Loaf Pans	B	350°	40-60	
Cookies					
Brownies	Metal or Glass Pans	B, C	325°-350°	25-35	Bar cookies from mix use same time.
Drop	Cookie Sheet	B, C	350°-400°	10-20	Use Shelf C and increase temp. 25°F. to 50°F. for more browning.
Refrigerator	Cookie Sheet	B, C	400°-425°	6-12	
Rolled or sliced	Cookie Sheet	B, C	375°-400°	7-12	
Fruits, Other Desserts					
Baked apples	Glass or Metal Pans	A, B, C	350°-400°	30-60	
Custard	Glass Custard Cups or Casserole (set in pan of hot water)	B	300°-350°	30-60	Reduce temp. to 300°F. for large custard.
Puddings, rice and custard	Glass Custard Cups or Casserole	B	325°	50-90	Cook bread or rice pudding with custard base 80 to 90 minutes.
Pies					
Frozen	Foil Pan on Cookie Sheet	A	400°-425°	45-70	Large pies use 400°F. and more time.
Meringue	Spread to crust edges	B, A	325°-350°	15-25	To quickly brown meringue, use 400°F. for 8 to 10 minutes.
One crust	Glass or Satin-finish Metal Pan	A, B	400°-425°	40-60	Custard fillings require lower temperature, longer time.
Two crust	Glass or Satin-finish Metal Pan	B	400°-425°	40-60	
Pastry shell	Glass or Satin-finish Metal Pan	B	450°	12-15	
Miscellaneous					
Baked potatoes	Set on Oven Shelf	A, B, C	325°-400°	60-90	Increase time for larger amount or size.
Scalloped dishes	Glass or Metal Pan	A, B, C	325°-375°	30-60	
Souffles	Glass	B	300°-350°	30-75	

Roasting

Roasting is cooking by dry heat. Tender meat or poultry can be roasted uncovered in your oven. Roasting temperatures, which should be low and steady, keep spattering to a minimum. When roasting, it is not necessary to sear, baste, cover or add water to your meat.

Roasting is really a baking procedure used for meats. Therefore, oven controls are set for BAKE or TIME BAKE. (You may hear a slight clicking sound, indicating the oven is working properly.) Roasting is easy; just follow these steps:

Step 1: Check weight of meat, and place, fat side up, on roasting rack in a shallow pan. (Broiler pan with rack is a good pan for this.) Line broiler pan with aluminum foil when using pan for marinating, cooking with fruits, cooking heavily cured meats, or basting food during cooking. Avoid spilling these materials on oven liner or door.

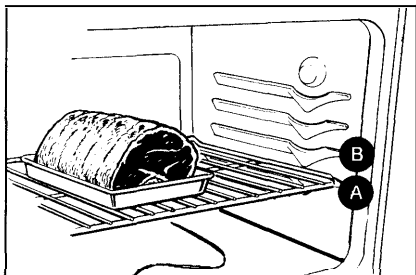

Step 2: Place in oven on shelf in A or B position. No preheating is necessary.



Step 3: Touch BAKE pad.

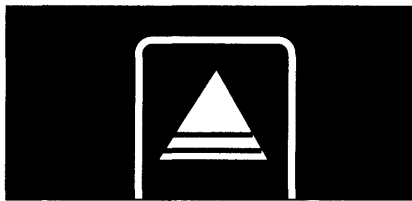

Step 4: Touch INCREASE pad. The latest oven set temperature appears in the display.

Step 5: Press INCREASE or DECREASE pad until desired temperature is displayed.

The word "ON" and the changing oven temperature will be displayed as the oven heats up. When the oven reaches the set temperature a tone will sound.

To change oven temperature during BAKE cycle, touch BAKE pad and then INCREASE or DECREASE pad to get new temperature.



Step 6: Touch CLEAR/OFF when baking is finished and then remove food from oven.

Step 7: Most meats continue to cook slightly while standing, after being removed from the oven. Standing time recommended for roasts is 10 to 20 minutes. This allows roasts to firm up and makes them easier to carve. Internal temperature will rise about 5° to 10°F.; to compensate for temperature rise, if desired, remove the roast from oven sooner (at 5° to 10°F. less than temperature in the Roasting Guide).

NOTE: You may wish to TIME BAKE, as described in the Baking section of this book, to turn oven on and off automatically.

Remember that food will continue to cook in the hot oven and therefore should be removed when the desired internal temperature has been reached.

For Frozen Roasts

- Frozen roasts of beef, pork, 1 lb., etc., can be started without thawing, but allow 10 to 25 minutes per pound additional time (10 minutes per pound for roasts under 5 pounds, more time for larger roasts).
- Thaw most frozen poultry before roasting to ensure even doneness. Some commercial frozen poultry can be cooked successfully without thawing. Follow directions given on package label.

Questions and Answers

Q. Is it necessary to check for doneness with a meat thermometer?

A. Checking the finished internal temperature at the completion of cooking time is recommended. Temperatures are shown in Roasting Guide on opposite page. For roasts over 8lbs., cooked at 300°F. with reduced time, check with thermometer at half-hour intervals after half the cooking time has passed.

Q. Why is my roast crumbling when I try to carve it?

A. Roasts are easier to slice if allowed to cool 10 to 20 minutes after removing from oven. Be sure to cut across the grain of the meat.

Q. Do I need to preheat my oven each time I cook a roast or poultry?

A. It is rarely necessary to preheat your oven. Preheat only for very small roasts, which cook a short length of time.

Q. When buying a roast, are there any special tips that would help me cook it more evenly?

A. Yes. Buy a roast as even in thickness as possible, or buy rolled roasts.

Q. Can I seal the sides of my foil "tent" when roasting a turkey?

A. Sealing the foil will steam the meat. Leaving it unsealed allows the air to circulate and brown the meat.

Roasting Guide

1. Position oven shelf at B for small-size roasts (3 to 7 lbs.) and at A for larger roasts.

2. Place meat fat-side-up, or poultry breast-side-up, on broiler pan or other shallow pan with trivet. Do not cover. Do not stuff poultry until just before roasting. Use meat thermometer for more accurate doneness. (Do not place thermometer in stuffing.)

3. Remove fat and drippings as necessary. Baste as desired.

4. Standing time recommended for roasts is 10 to 20 minutes. This allows roasts to firm up and make them easier to carve. Internal temperature will rise about 5° to 10° F.; to compensate for temperature increase, if desired, remove the roast from oven sooner (at 5° to 10° F. less than temperature in this guide).

5. Frozen roasts can be conventionally roasted by adding 10 to 25 minutes per pound more time than given in guide for refrigerated roasts. (10 minutes per pound for roasts under 5 pounds.) Defrost poultry before roasting.

Type	Oven Temperature	Doneness	Approximate Roasting Time in Minutes per Pound		Internal Temperature °F.
Meat			3 to 5 lbs.	6 to 8 lbs.	
Tender cuts; rib, high quality sirloin tip, rump or top round*	325°	Rare: Medium: Well Done:	24-30 30-35 35-45	18-22 22-25 28-33	130°-140° 150°-160° 170°-185°
Lamb leg or bone-in shoulder*	325°	Rare: Medium: Well Done:	21-25 25-30 30-35	20-23 24-28 28-33	1300-1400 150°-160° 170°-185°
Veal shoulder, leg or loin*	325°	Well Done:	35-45	30-40"	170°-180°
Pork loin, rib or shoulder*	325°	Well Done:	35-45	30-40	170°-180°
Ham, precooked	325°	To Warm:	10 minutes per pound (ml) weight		125°-130°
Ham, raw	325°	Well Done:	Under 10 lbs. 20-30	10 to 15 lbs. 17-20	170°
For boneless rolled roast over 6 inches thick, add 5 to 10 minutes per pound to times given above.					
Poultry			3 to 5 lbs.	Over 5 lbs.	
Chicken or Duck	325°	Well Done:	35-40	30-35	185°-1900
Chicken piece\	350°	Well Done:	35-40		185°-1900
Turkey	325°	Well Done:	10 to 15 lbs. 20-25	Over 15 lbs. 15-20	In thigh: 185°-190°

Broiling

Broiling is cooking food by intense radiant heat from the upper unit in the oven. Most fish and tender cuts of meat can be broiled. Follow these steps to keep spattering and smoking to a minimum.

Step 1: If meat has fat or gristle near edge, cut vertical slashes through both about 2" apart. If desired, fat may be trimmed, leaving layer about 1/8" thick.

Step 2: Place meat on broiler rack in broiler pan. Always use rack so fat drips into broiler pan; otherwise juices may become hot enough to catch fire.

Step 3: Position shelf on recommended shelf position as suggested in Broiling Guide. Most broiling is done on C position, but if your range is connected to 208 Volts, you may wish to use a higher position.

Step 4: Leave door ajar a few inches (except when broiling chicken). The door stays open by itself, yet proper temperature is maintained in the oven.

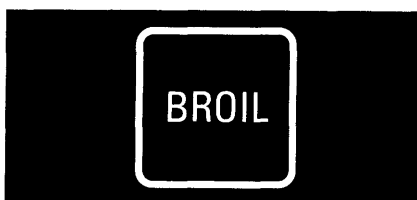

Step 5: Touch BROIL pad.



Step 6: Select LO Broil (450°F.) by tapping INCREASE pad once. Select HI Broil (550°F.) by tapping INCREASE pad twice.

To change from HI Broil to LO Broil, touch the BROIL pad then tap DECREASE pad once.

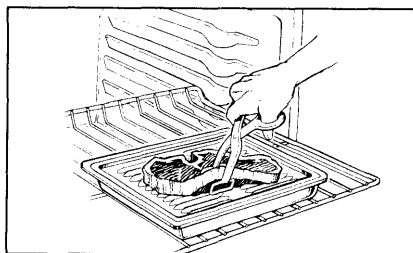

Step 7: Turn food only once during cooking. Time foods for first side per Broiling Guide.

Turn food, then use times given for second side as a guide to preferred doneness. (Where two thicknesses and times are given together, use first times given for thinnest food.)

Step 8: When Broiling is completed touch CLEAR/OFF. Serve food immediately, and leave pan outside oven to cool during meal for easiest cleaning.

Use of Aluminum Foil

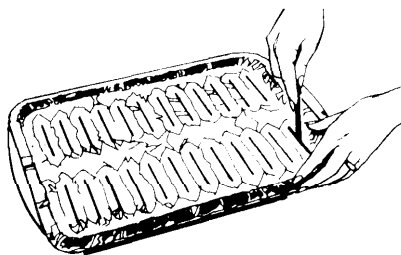

You can use aluminum foil to line your broiler pan and broiler rack. However, you must mold the foil tightly to the rack and cut slits in it just like the rack,

Without the slits, the foil will prevent fat and meat juices from draining to the broiler pan. The juices could become hot enough to catch on fire. If you do not cut the slits, you are frying, not broiling.

Questions & Answers

Q. Why should I leave the door closed when broiling chicken?

A. Chicken is the only food recommended for closed-door broiling. This is because chicken is relatively thicker than other foods you broil. Closing the door holds more heat in the oven which allows chicken to cook evenly throughout.

Q. When broiling, is it necessary to always use a rack in the pan?

A. Yes. Using the rack suspends the meat over the pan. As the meat cooks, the juices fall into the pan, thus keeping meat drier. Juices are protected by the rack and stay cooler, thus preventing excessive spatter and smoking.

Q. Should I salt the meat before broiling?

A. No. Salt draws out the juices and allows them to evaporate. Always salt after cooking. Turn meat with tongs; piercing meat with a fork also allows juices to escape. When broiling poultry or fish, brush each side often with butter.

Q. Why are my meats not turning out as brown as they should?

A. In some areas, the power (voltage) to the range may be low. In these cases, preheat the broil unit for 10 minutes before placing broiler pan with food in oven. Check to see if you are using the recommended shelf position. Broil for longest period of time indicated in the Broiling Guide. Turn food only once during broiling.

Q. Do I need to grease my broiler rack to prevent meat from sticking?

A. No. The broiler rack is designed to reflect broiler heat, thus keeping the surface cool enough to prevent meat from sticking to the surface. However, spraying the broiler rack lightly with a vegetable cooking spray before cooking will make cleanup easier.

Broiling Guide

1. Always use broiler pan and rack hat comes with your oven. It is designed to minimize smoking and spattering by trapping juices in the shielded lower part of the pan.

2. Oven door should be ajar for all foods except chicken: there is a special position on door which holds door open correctly.

3. For steaks and chops, slash fat evenly around outside edges of meat. To slash, cut crosswise

through outer fat surface just to the edge of the meat. Use tongs to turn meat over to prevent piercing meat and losing juices.

4. If desired, marinate meats or chicken before broiling, or brush with barbecue sauce last 5 to 10 minutes only.

5. When arranging food on pan, do not let fatty edges hang over sides, which could soot oven with fat dripping.

6. Broiler does not need to be preheated. However, for very thin foods, or to increase browning, preheat if desired.

7. Frozen steaks can be conventionally broiled by positioning the oven shelf at next lowest shelf position and increasing cooking time given in this guide 1 1/2 times per side.

Food	Quantity and/or Thickness	Shelf ^o Position	HI or LO Broil	First Side Time, Minutes	Second Side Time, Minutes	Comments
Bacon	1/2 lb. (about 8 thin slices)	D	HI	5	7 1/2	Arrange in single layer.
Ground Beef Well Done	1 lb. (4 patties) 1/2 to 3/4 in. thick	D	HI	8-9	6-7	Space evenly. Up to 8 patties take about same time.
Beef Steaks						
Rare	1 inch thick	D	HI	9	7	Steaks less than 1 inch thick cook through before browning. Pan frying is recommended, Slash fat.
Medium	(1 to 1 1/2 lbs.)	D		12-13	6-7	
Well Done		D		13	8-9	
Rare	1 1/2 in. thick	D		10	6-7	
Medium	(2 to 2 1/2 lbs.)	D		15	9-12	
Well Done		D		25	1 (>1x)	
Chicken (450°)	1 whole (2 to 2 1/2 lbs.), split lengthwise	B	1 ()	28-30	1 x-20	Reduce time about 5 to 10 minutes per side for cut-up chicken. Brush each side with melted butter. Broil skin-side-down first and broil with door closed.
Bakery Products						
Bread (Toast) or Toaster Pastries	2 to 4 slice 1 pkg. (2)	D	HI	2-3	1/2-1	Space evenly. Place English muffins cut-side-up and brush with butter, if desired.
English Muffins	2 (split)	D		3-4		
Lobster Tails	2-4 (6- to 8-oz. each)	C	HI	13-16	Do not turn over.	Cut through back of shell. Spread open. Brush with melted butter before and after half of broiling time.
Fish	1-lb. fillets 1/4 to 1/2 in. thick	D	HI	5	5	Handle and turn very carefully. Brush with lemon butter before and during cooking if desired. Preheat broiler to increase browning.
Ham Slices (450°) (precooked)	1 in. thick	C	LO	8	8	Increase time 5 to 10 minutes per side for 1 1/2 inch thick or home cured.
Pork Chops Well Done	2 (1/2 inch) 2 (1 in. thick) about 1 lb.	D ()	HI	10-12 12-13	4-5 8-9	Slash fat.
Lamb Chops						
Medium	2 (1 inch)	D	HI	8	4-7	Slash fat.
Well Done	about 1 () to 1 1/2 oz.	D		10	10	
Medium	2 (1 1/2 inch)	D		10	4-6	
Well Done	about 1 lb.	C		17	12-14	
Wieners and similar precooked sausages, bratwurst	1-lb. pkg. (1 ())	D	HI	6	1-2	If desired, split sausages in half lengthwise; cut into 5- to 6-inch pieces

Operating the Self-Cleaning Oven

Normal Cleaning Time: 3 hours

Before a Clean Cycle

The range must be completely cool in order to set the self-clean cycle.

Step 1: Remove the broiler pan, broiler rack, all cookware and any aluminum foil from the oven—they can not withstand the high cleaning temperatures. (Oven shelves may be left in oven. Note: Shelves will discolor after the self-clean cycle.)

Step 2: Wipe up heavy soil on the oven bottom.

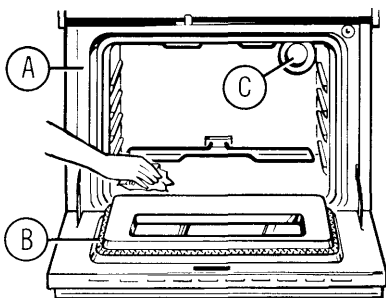

A. Oven Front Frame

B. Oven Door Gasket

C. Oven Light.

Step 3: Clean spatters or spills on oven front frame (A) and oven door outside gasket (B) with a dampened cloth. Polish with a dry cloth. Do not clean gasket (B). Never use a commercial oven cleaner in or around self-cleaning oven.

Step 4: Close the door and make sure the oven light (C) is off.

Oven shelves may be cleaned in the self-cleaning oven. However, they will darken, lose their luster and become hard to slide. Wipe the shelf supports with cooking oil after self-cleaning to make shelves slide more easily.

Caution: Chrome trim rings around the surface should never be cleaned in the self-cleaning oven. Neither should reflector pans or foil or shiny chrome.

Do not use commercial oven cleaners or oven protectors in or near the self-cleaning oven. A combination of any of these products plus the high clean cycle temperatures may damage the porcelain finish of the oven.

Important

The oven door must be closed and latched and all controls must be set correctly for the clean cycle to work properly.

How to Set Oven for Cleaning

Step 1: Follow steps at left to prepare the oven for cleaning.

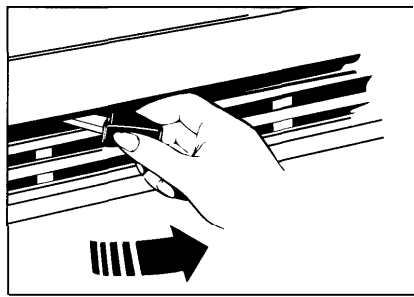

Step 2: Close the oven door and slide latch handle to the right as far as it will go.



Step 3: Touch CLEAN pad.

Step 4: Touch INCREASE or DECREASE pad.

Step 5: Press INCREASE or DECREASE pad until desired Clean Time is displayed.

Clean Time is normally 3 hours. You can change the Clean Time to anywhere between 2 and 4 hours, depending on how dirty the oven is.

The self-clean cycle will automatically begin within a few seconds and the word "ON" will appear on the display. When the oven heats to a high temperature, the word "LOCK" will be displayed and, a short time later, the door latch handle will be locked in position. It will not be possible to open the oven door until the temperature drops below the lock temperature.

The oven will smoke the first time you use the self-clean cycle even though you have wiped up any excessive soil. This is normal and should stop in about 10 minutes. To help control the smoke, turn on the exhaust fan over the range when you use the self-clean cycle the first time.

After a Clean Cycle

When the clean cycle is finished, the word "CLEAN" will go out in the display and the oven will begin to cool. When the oven temperature has fallen below the locking temperature (about 20-30 minutes after the word "CLEAN" goes out at the end of the clean cycle), the word "LOCK" goes out and the door can be opened.

Step 6: When the LOCK light is off, slide latch handle to the left as far as it will go and open the door.

Never force the latch handle. Wait until the word "LOCK" goes out in the display. Forcing the latch handle may damage the door lock.

After a clean cycle, you may notice some white ash in the oven. Just wipe it up with a damp cloth.

If white spots remain, remove them with a soap-filled steel wool pad. Be sure to rinse thoroughly with a vinegar and water mixture. These deposits are usually a salt residue that cannot be removed by the clean cycle.

If the oven is not clean after one clean cycle, the cycle may be repeated.

How to Delay Start of Cleaning

Delay Start is setting the oven timer to start the clean cycle automatically at a later time than the present time of day. **NOTE:** Before beginning make sure the oven clock shows the correct time of day.

Quick Reminder— Delay Start for Self-Clean:

- 1.) Prepare oven for cleaning.
- 2.) Touch CLEAN pad.
- 3.) Touch INCREASE pad.
- 4.) Touch STOP TIME pad.

Time that appears is 3 hours later than the time of day. Press INCREASE pad until the Stop Time you desire appears in the display. The self-clean cycle will automatically begin 3 hours before the stop time you select.

For example: Let's say it's 7:00 and you want the oven to begin self-cleaning at 9:00 after you're finished in the kitchen. The oven is just soiled a normal amount so the normal Clean Time of 3 hours is preferred.

Step 1: Prepare the oven for cleaning.

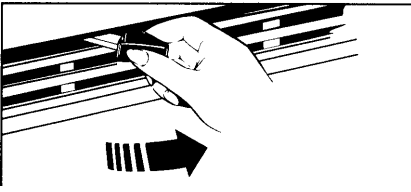

Step 2: Close the oven door and slide latch handle to the right as far as it will go.



Step 3: Touch CLEAN pad.

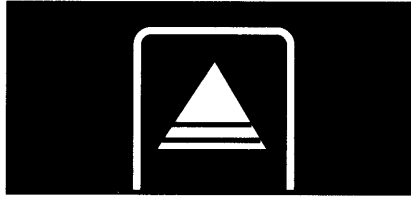

Step 4: Touch INCREASE pad,

Step 5: Clean time for heavy soil can be set for 4 hours. If a longer or shorter Clean Time is desired, press INCREASE or DECREASE pad until desired Clean Time is displayed.



Step 6: Touch STOP TIME pad. "10:00" appears on display and "STOP TIME" flashes. The control automatically sets Stop Time by adding the Clean Time to the time of day. In this example, the time of day is 7:00 and the Clean Time is 3 hours. Adding 3 hours to the time of day equals 10:00.

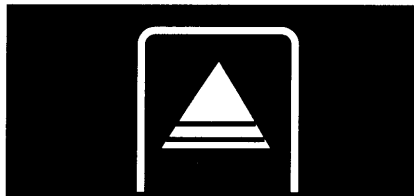

Step 7: Change Stop Time from 10:00 to 12:00 by pressing INCREASE pad until "12:00" appears in the display. The words "DELAY CLEAN" will also appear in the display.

The self-clean cycle will automatically begin at 9:00 and finish at 12:00. The word "ON" will appear on the display at 9:00.

When the oven heats to a high temperature, the word "LOCK" will be displayed and, a short time later, the door latch handle will be locked in position. It will not be possible to open the oven door until the temperature drops below the lock temperature.

When the clean cycle is finished, the word "CLEAN" will go out in the display and the oven will begin to cool. When the oven temperature has fallen below the locking temperature (about 20-30' minutes after the word "CLEAN" goes out at the end of the clean cycle), the word "LOCK" goes out and the door can be opened.

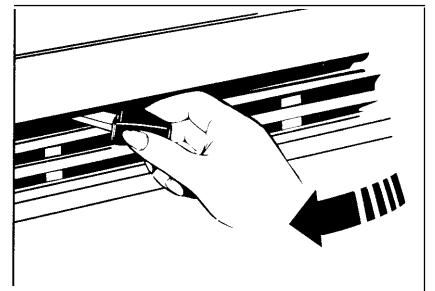

Step 8: When the LOCK light is off, slide latch handle to the left as far as it will go and open the door.

Never force the latch handle. Wait until the word "LOCK" goes out in the display. Forcing the latch handle may damage the door lock.

operating the Self-Cleaning oven (continued)

Questions and Answers

Q. If my oven clock is not working, can I still self-clean my oven?

A. No. The range clock is needed to help start and stop your self-cleaning cycle.

Q. Can I use commercial oven cleaners on any part of my self-cleaning oven?

A. No cleaners or coatings should be used around any part of this oven. If you do use them and do not thoroughly rinse the oven with water, wiping it absolutely clean afterwards, the residue can scar the oven surface and damage metal parts the next time the oven is automatically cleaned.

Q. Can I clean the Woven Gasket around the oven door?

A. No, this gasket is essential for a good oven seal, and care must be taken not to rub, damage or move this gasket.

Q. What should I do if excessive smoking occurs during cleaning?

A. This is caused by excessive soil. Touch the CLEAWOFF pad. Open windows to rid room of smoke. Wait until the oven has cooled (about 20-30 minutes) and the word "LOCK" is off in the display. Wipe up the excess soil and reset the clean cycle.

Q. Is the "crackling" sound I hear during cleaning normal?

A. Yes. This is the sound of the metal heating and cooling during both the cooking and cleaning functions.

Q. Should there be any odor during the cleaning?

A. Yes, there maybe a slight odor during the first few cleanings. Failure to wipe out excessive soil might also cause a strong odor when cleaning.

Q. What causes the hair-like lines on the enameled surface of my oven?

A. This is a normal condition, resulting from heating and cooling during cleaning. These lines do not affect how your oven performs.

Q. Why do I have ash left in my oven after cleaning?

A. Some types of soil will leave a deposit which is ash. It can be removed with a damp sponge or cloth.

Q. My oven shelves do not slide easily. What is the matter?

A. After many cleanings, oven shelves may become so clean they do not slide easily. To make shelves slide more easily, after each self-cleaning function dampen fingers with a small amount of cooking oil and rub lightly over sides of shelf where they contact shelf supports.

Q. My oven shelves have become gray after the self-clean cycle. Is this normal?

A. Yes. After the self-clean cycle, the shelves may lose some luster and discolor to a deep gray color.

Q. The word "door" appeared on the display when I selected the Clean Cycle. What's wrong?

A. The door latch handle must be moved all the way to the right. Move the latch handle and cleaning will start.

Adjusting Oven Thermostat

When cooking a food for the first time in your new oven, use time given on recipes as a guide. Oven thermostats, over a period of years, may "drift" from the factory setting and the differences in timing between an old and a new oven of 5 to 10 minutes are not unusual and you may be inclined to think that the new oven is not performing correctly. However, your new oven has been set correctly at the factory and is more apt to be accurate than the oven it replaced.

If you think the oven should be hotter or cooler, you can adjust it yourself. To decide how much to change the temperature, set the oven temperature 25°F. higher or lower than the temperature in your recipe, then bake. The results of this "test" should give you an idea of how much the temperature should be changed.

To adjust temperature:

1. Touch BAKE pad.
2. Select an oven temperature between 500°F. and 550°F.
3. Immediately, before BAKE indicator stops flashing, press and hold the BAKE pad for about 4 seconds. The red display will change to the oven adjustment display.
4. The oven temperature can be adjusted up to (+) 35°F. hotter or (-) 35°F. cooler. Use the INCREASE or DECREASE pads to select the desired change in the red display.
5. When you have made the adjustment, press the CLEAWOFF pad to go back to the time of day display. Use your oven as you would normally.

NOTE: This adjustment will not affect Broil or Clean temperatures. It will be remembered when power is removed.

Care and Cleaning

(See Cleaning Guide)

Proper care and cleaning are important so your range will give you efficient and satisfactory service. Follow these directions carefully in caring for your range to assure safe and proper maintenance.

Oven Vent Duct

Your range is vented through a duct located under the right rear Calrod® unit. Clean the duct often.

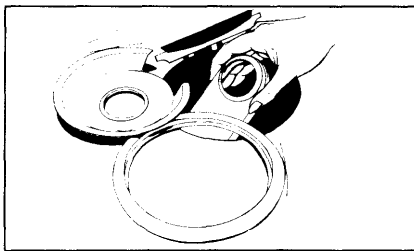

To remove:

- Make sure unit is cool.
- Lift up right rear surface unit.
- Remove one piece bowl or trim ring and drip pan,
- Lift out oven vent duct.

To replace:

- Place the part over the oven vent located below the cooktop with opening of the duct under the round opening in the reflector pan. It is important that the duct is in the correct position so moisture and vapors from the oven can be released during oven use. **NOTE:** Never cover the hole in the oven vent duct with aluminum foil or any other material. This prevents the oven vent from working properly during any cooking cycle.

Cleaning Under the Range

The area under the range can be reached easily for cleaning by removing the bottom drawer. To remove, pull drawer out all the way, tilt up the front and remove it. To replace, insert glides at back of drawer beyond top on range glides. Lift drawer if necessary to insert easily. Let front of drawer down, then push in to close.

Oven Lamp Replacement

CAUTION: Before replacing your oven bulb, disconnect the electrical power for your range at the main fuse or circuit breaker panel. Be sure to let the lamp cover and bulb cool completely.

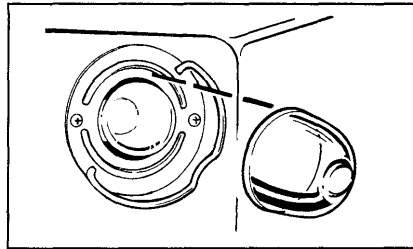

The oven lamp (bulb) is covered with a glass removable cover which is held in place with a bail-shaped wire. Remove oven door, if desired, to reach cover easily.

To remove:

- Hold hand under cover so it doesn't fall when released. With fingers of same hand, firmly push back wire bail until it clears cover. Lift off cover. **DO NOT REMOVE ANY SCREWS TO REMOVE COVER.**
- Replace bulb with 40-watt home appliance bulb.

To replace cover:

- Place it into groove of lamp receptacle. Pull wire bail forward to center of cover until it snaps into place. When in place, wire holds cover firmly. Be certain wire bail is in depression in center of cover.
- Connect electric power to range.

Finishes

The porcelain enamel finish is sturdy but breakable if misused. This finish is acid-resistant. However, any acid foods spilled (such as fruit juices, tomato or vinegar) should not be permitted to remain on the finish.

Removable Oven Door

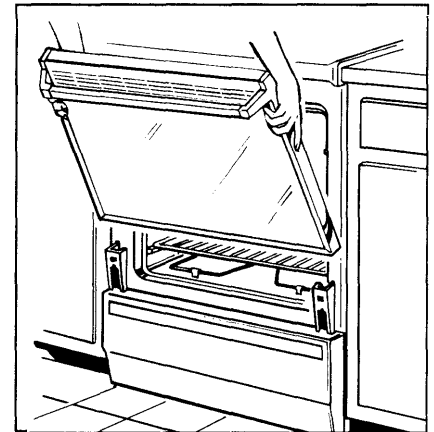

To REMOVE door, open to BROIL position, or where you feel hinge catch slightly. Grasp door at sides; lift door up and away from hinges.

To REPLACE, grasp door at sides. Line up door with hinges and push door firmly into place.

Control Panel and Knobs

Clean up any spills or spatters with a damp cloth. Remove heavier soil with warm, soapy water.

Clean touch pads with mild liquid dish detergent and a soft cloth. Rub touch pads lightly. **CAUTION: DO NOT USE ABRASIVES OF ANY KIND ON THE CONTROL PANEL.** The lettering on the pads is sensitive to abrasives and pressure.

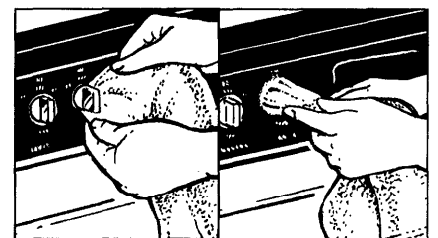

The control knobs may be removed for easier cleaning. To remove knob, pull it straight off the stem. If knob is difficult to remove, place a towel or dish cloth between the knob and control panel and pull gently. Wash knobs in soap and water but do not soak.

Cooktop Surface Lamp

(on models so equipped)

WHEN CHANGING A COOKTOP LAMP, DO NOT TOUCH THE METAL AT ENDS OF LAMP.

Your cooktop light is easily replaced with a fluorescent tube of the same wattage. Make sure the power to the range is disconnected at main fuse or circuit breaker panel or pull plug.

To remove:

- Lift the 1 amp cover by pulling the bottom edge toward you and then up.
- Place fingers on top near each end of light bulb.
- Roll top of bulb gently toward front of range and gently pull the bulb from the socket, making sure it does not hit the lamp cover.

To replace:

- Place fingers on top near each end of light bulb.
- Press bulb into slots until it snaps into place.
- Move 1 amp cover down and snap into place.

Surface Units

Clean the area under the drip pan/rings often. Built-up soil, especially grease, may catch fire. To make cleaning easier, tilt-lock units lift up and lock in the up position, and plug-in units are removable.

Caution: Be sure all controls are turned to OFF and surface units are cool before attempting to lift or remove them.

After lifting the tilt-lock unit or removing a plug-in unit, remove the drip pan/rings and clean them according to directions in the Cleaning Guide. Wipe around the edges of the surface unit opening. Clean the area below the unit. Rinse all washed areas with a damp cloth or sponge.

Tilt-Lock Unit

(on models so equipped)

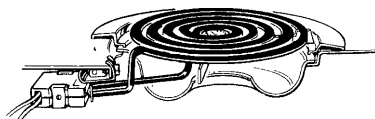

Tilt-lock units cannot be removed.

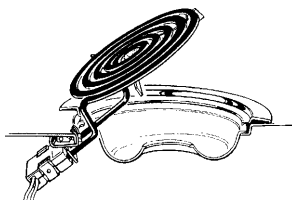

You can lift a tilt-lock unit upward about 6 inches and it will lock in the up position.

To reposition the tilt-lock unit:

- Replace the drip pan into the recess in the cooktop.
- If you have a separate trim ring, put it in place over the drip pan. The drip pan must be under the trim ring.
- Guide the surface unit into place so it rests evenly.

Plug-In Units

(on models so equipped)

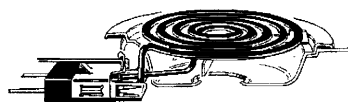

Plug-in units can be removed.

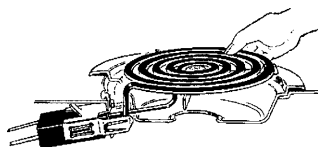

Lift a plug-in unit about 1 inch above the trim ring—just enough to grasp it—and pull it out.

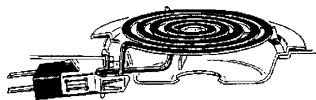

Do not lift a plug-in unit more than 1 inch. If you do, it may not lie flat on the trim ring when you plug it back in.

Repeated lifting of the plug-in unit more than 1 inch above the trim ring can permanently damage the receptacle.

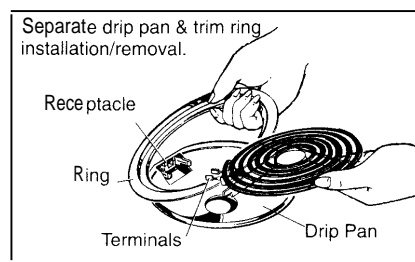

To replace a plug-in unit:

- Replace the drip pan into the recess in the cooktop. Make sure opening in pan lines up with receptacle. If you have a separate trim ring, put it in place over the drip pan. The drip pan must be under the trim ring.
- Insert the terminals of the plug-in unit through the opening in the drip pan and into the receptacle.
- Guide the surface unit into place so it rests evenly.

CAUTION

- Do not attempt to clean plug-in surface units in an automatic dishwasher.
- Do not immerse plug-in surface units in liquids of any kind.
- Do not bend the plug-in surface unit plug terminals.
- Do not attempt to clean, adjust or in any way repair the plug-in receptacle.

Cleaning Guide

NOTE: Let oven parts cool before touching or handling.

PART	MATERIALS TO USE	GENERAL DIRECTIONS	
Broiler Pan and Rack	<ul style="list-style-type: none"> • Soap and Water • Soap-Filled Scouring Pad • Plastic Scouring Pad • Dishwasher-Safe 	Drain fat and cool pan and rack slightly. (Do not let soiled pan and rack stand in oven to cool.) Sprinkle on detergent. Fill the pan with warm water and spread a damp cloth or paper towel over the rack. Let pan and rack stand for a few minutes. Wash; scour if necessary. Rinse and dry. OPTION: The broiler pan and rack may also be cleaned in a dishwasher.	
Control Panel	<ul style="list-style-type: none"> • Damp Cloth • Paper Towel • Soap and Water 	DO NOT USE abrasives, cleaning powders, steel wool or plastic scouring pads. They will mar the surface.	Wash control panel with soap and water using a soft cloth. Rinse and dry with a soft cloth.
Outside Glass Finish	<ul style="list-style-type: none"> • Soap and Water 	Clean outside of cooled black glass door with a glass cleaner that does not contain ammonia. Do not allow water to run down inside openings in the glass while cleaning.	
Metal Parts Including Chrome Side Trims and Trim Strips	<ul style="list-style-type: none"> • Soap and Water 	DO NOT USE steel wool, abrasives, ammonia, acids or commercial oven cleaners.	To safely clean surfaces: wash, rinse, and then dry with a soft cloth. Do not allow water to run down inside the surface of the glass while cleaning.
Porcelain Enamel and Painted Surfaces*	<ul style="list-style-type: none"> • Paper Towel • Dry Cloth • Soap and Water 	DO NOT USE oven cleaners, cleansing powders or harsh abrasives. These might scratch the surface.	If acids should spill on the oven while it is hot, use a dry paper towel or cloth to wipe them right away. When the surface has cooled, wash and rinse. For other spills, such as fat splatterings, etc., wash with soap and water when cooled and then rinse. Polish with dry cloth.
Inside Oven Door*	<ul style="list-style-type: none"> • Soap and Water 	DO NOT USE oven cleaners, cleansing powders or harsh abrasives.	Clean ONLY the door liner outside the gasket. The door is automatically cleaned if the oven is in the self-cleaning cycle. If spillover or spattering should occur in cooking, wipe the door with soap and water. DO NOT rub or damage the gasket.
Oven Liner (Self-Cleaning Oven)	<ul style="list-style-type: none"> • Soap and Water 	Allow to cool before cleaning. Frequent wiping with mild soap and water will prolong the time between self-cleaning cycles. Be sure to rinse thoroughly to avoid additional stains.	
Oven Gasket *		Avoid getting ANY cleaning materials on the gasket.	
Shelves (See Self-Cleaning Oven Directions)	<ul style="list-style-type: none"> • Soap and Water • Dishwasher-Safe 	Shelves can be cleaned with the self-cleaning function in the oven. However, they will darken, lose their luster and become hard to slide. Wipe the shelf supports with cooking oil after self-cleaning to make shelves slide more easily. For heavy soil, clean by hand and rinse thoroughly.	
Bake Unit and Broil Unit		Do not clean the bake unit or broil unit. Any soil will burn off when the unit is heated. NOTE: The bake unit is hinged and can be lifted gently to clean the oven floor. If spillover, residue or ash accumulates around the bake unit, gently wipe around the unit with warm water.	
Storage Drawer	<ul style="list-style-type: none"> • Soap and Water 	For cleaning, remove drawer by pulling it all the way open, tilting up the front and then lifting the drawer out. Wipe with a damp cloth or sponge and replace the drawer. Never use harsh abrasives or scouring pads.	
Oven Control Knobs		See Care and Cleaning section for cleaning instructions.	
Calrod® Surface Unit Coils		Spatters and spills burn away when coils are heated. After meal, remove all cookware from surface units and heat soiled units at HI. Let soil burn off for about one minute and switch units to OFF. Do not get cleaning materials on coils. If you do, wipe off with a damp paper towel <i>before</i> heating surface units. DO NOT handle the unit before completely cooled. DO NOT attempt to clean plug-in units in the self-cleaning oven. DO NOT immerse plug-in units in any kind of liquid. DO NOT wash in dishwasher.	
Chrome-Plated Trim Rings	<ul style="list-style-type: none"> • Soap and Water • Stiff-Bristled Brush • Plastic Scouring Pad 	DO NOT CLEAN IN SELF-CLEANING OVEN. Rings will discolor. Wipe after each cooking so unnoticed spatter will not burn on next time you cook. To remove burned-on spatters, use any or all cleaning materials mentioned. Rub lightly with scouring pad to prevent scratch in: of the surface.	
Porcelain Enamel Drip Pans	<ul style="list-style-type: none"> • Soap and Water • Plastic Scouring Pad 	Porcelain drip pans can be cleaned in dishwasher or by hand. After pans cool slightly, soak in detergent and hot water, wash with a plastic scouring pad if necessary, then rinse and dry	

*Spillage of marinades, fruit juices, tomato sauces and basting materials containing acids may cause discoloration and should be wiped up immediately. Take care not to touch hot portion of oven. When surface is cool, clean and rinse.



Questions? Use This Problem Solver

PROBLEM	POSSIBLE CAUSE AND REMEDY
OVEN WILL NOT WORK	<ul style="list-style-type: none">• Plug on range is not completely inserted in the electrical outlet.• The circuit breaker in your house has been tripped, or a fuse has been blown.• Oven controls not properly set.• Door left in locked position after cleaning.
OVEN LIGHT DOES NOT WORK	<ul style="list-style-type: none">• Light bulb is loose or defective. Tighten or replace.• Switch operating oven light is broken. Call for service.
SURFACE LIGHT DOES NOT WORK (on models so equipped)	<ul style="list-style-type: none">• Fluorescent lamp is loose or defective. Adjust or replace.• Press switch for 2 seconds. If lamp does not come on, repeat.• Switch operating light is broken. Call for service.
OVEN DOES NOT COOK PROPERLY	<ul style="list-style-type: none">• Aluminum foil being used improperly in oven.• Oven vent blocked on top of range.• Range or oven shelf not level.• Incorrect cookware being used. Check Baking Guide for cookware tips.• Clock set incorrectly.• Controls set incorrectly. Review each cooking section.• Shelf position is incorrect. Check Baking, Roasting and Broiling Guides.
FOOD DOES NOT BROIL PROPERLY	<ul style="list-style-type: none">• OVEN SET knob not set at BROIL.• OVEN TEMP knob not set at BROIL.• Door not left ajar as recommended.• Improper shelf position being used. Check Broiling Guide.• Necessary preheating was not done.• Food is being cooked on hot pan.• Cookware is not suited for broiling.• Aluminum foil used on the broil pan rack has not been fitted properly and slit as recommended.
FOOD DOES NOT ROAST OR BAKE PROPERLY	<ul style="list-style-type: none">• OVEN SET knob not set on BAKE.• OVEN TEMP knob not set correctly.• Shelf position is incorrect. Check Roasting or Baking Guides.• Oven shelf is not level.• Incorrect cookware or cookware of improper size is being used.• A foil tent was not used when needed to slow down browning during roasting.

(continued next page)

The Problem Solver (continued)

PROBLEM	POSSIBLE CAUSE AND REMEDY
CLOCK AND MINUTE/SECOND TIMER DO NOT WORK	<ul style="list-style-type: none"> . Make sure the electrical plug is plugged into a live, properly grounded power outlet. • Check for power outage. • Review Control, Clock and Timer section of this book.
CALROD® SURFACE UNITS NOT FUNCTIONING PROPERLY	<ul style="list-style-type: none"> • Surface units are not plugged in solidly. • Trim rings and drip pans are not set securely in the range top. • Surface unit controls are not properly set.
OVEN WILL NOT SELF-CLEAN	<ul style="list-style-type: none"> . Oven temperature is too high to set self-clean operation. Allow the range to cool to room temperature and reset the controls. • Door latch handle not moved all the way to the right.
OVEN DOOR WILL NOT UNLOCK	<ul style="list-style-type: none"> • Oven must cool below locking temperature (approximately 30 minutes after the clean cycle is complete).
OVEN NOT CLEAN AFTER CLEAN CYCLE	<ul style="list-style-type: none"> • Oven controls not set properly. • Heavily soiled ovens require 3 ½ to 4-hour Clean Time. • Heavy spillovers should be cleaned up before starting clean cycle.
“door” APPEARS ON DISPLAY	<ul style="list-style-type: none"> • Self-clean cycle has been selected but latch handle was not moved all the way to the right. Move latch handle. • Latch handle was moved to the right but another program other than self-clean was selected, Move latch handle to the right only when setting self-clean cycle.
CONTROL BEEPS AFTER ENTERING OVEN TIME OR STOP TIME	<ul style="list-style-type: none"> • This is reminding you to enter a bake temperature.
“F-” AND A NUMBER FLASH ON DISPLAY	<ul style="list-style-type: none"> • This is the function error code. If function error code appears during the self-clean function, check oven door latch—the latch handle may have been moved, even if only slightly, from the latched position. Make sure latch is moved to the right as far as it will go. Touch CLEAR/OFF pad. If function error code does not clear, disconnect power to the range and call for service.

If you need more help... call, toll free:
GE Answer Center®
800.626.2000
consumer information service

INSTALLATION INSTRUCTIONS

BEFORE YOU BEGIN

Read these instructions completely and carefully.

IMPORTANT: Save these instructions for the local electrical inspector's use.

IMPORTANT: OBSERVE ALL GOVERNING CODES AND ORDINANCES.

NOTE TO INSTALLER: Leave these instructions with the appliance after installation is completed.

NOTE TO CONSUMER: Keep this Use and Care Guide and Installation Instructions for future use.

NOTE: This appliance must be properly grounded.

TOOLS YOU WILL NEED

Large blade screwdriver

Channel lock pliers

ELECTRICAL REQUIREMENTS

CAUTION, FOR PERSONAL SAFETY:

DO NOT USE AN EXTENSION CORD WITH THIS APPLIANCE.

REMOVE HOUSE FUSE OR OPEN CIRCUIT BREAKER BEFORE BEGINNING INSTALLATION.

This appliance must be supplied with the proper voltage and frequency, and connected to an individual, properly grounded branch circuit, protected by a circuit breaker or time delay fuse, as noted on the rating plate.

Wiring must conform to National Electric Codes.

If the electric service provided does not meet the above specifications, it is recommended that a licensed electrician install an approved outlet.

Because range terminals are not accessible after range is in position, flexible service conduit or cord must be used.

STEP 1

PREPARE THE OPENING

1½" spacing is recommended from the range to adjacent vertical walls above cooktop surface.

Allow 30" minimum clearance between surface units and bottom of unprotected wood or metal top cabinet, and 15" minimum between countertop and adjacent cabinet bottom.

STEP 1 (cont.)

To eliminate the risk of burns or fire by reaching over heated surface units, cabinet storage space above the surface units should be avoided. If cabinet storage is to be provided, the risk can be reduced by installing a range hood that projects horizontally a min. of 5" beyond the bottom of the cabinets.

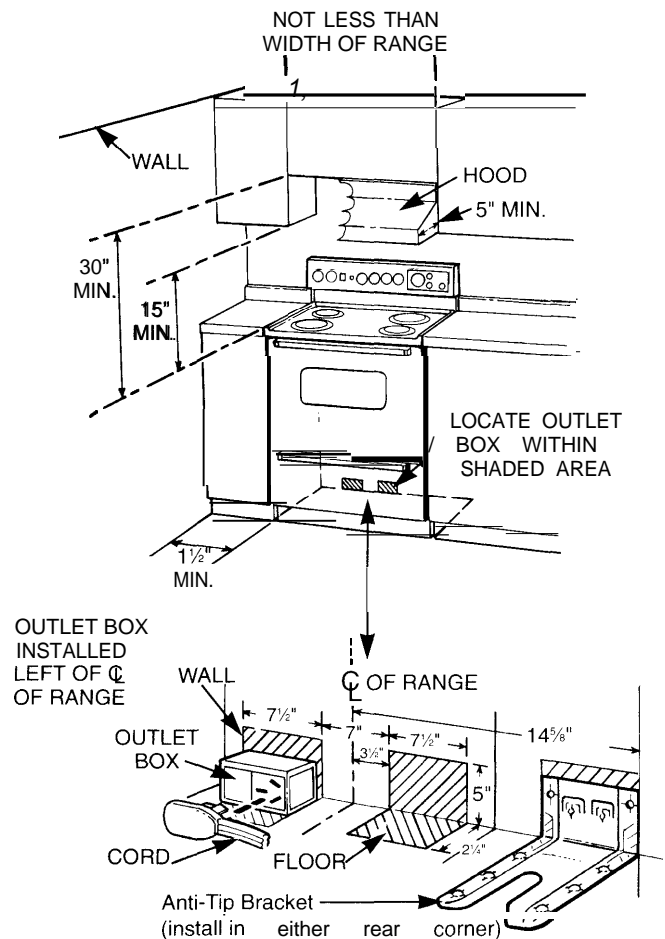

STEP 2

PREPARE FOR ELECTRICAL CONNECTION

Use only a 3-conductor, or if required a 4-conductor range cord set as noted below. These cord sets are provided with ring type terminals.

The electrical rating of the cord must be 125/250 volts minimum, 40 amperes.

NOTE: Only a 4-conductor cord is to be used when the appliance is installed in a mobile home or where local codes do not permit grounding through the neutral.

STEP 3

1. Locate connector block at the bottom rear of range and remove rear wiring cover.
2. Directly below the connector block is a hole with a knockout ring for accommodating conduit fittings. Brackets provided are used to support the flexible cord strain relief, which must be securely attached to the cord set.

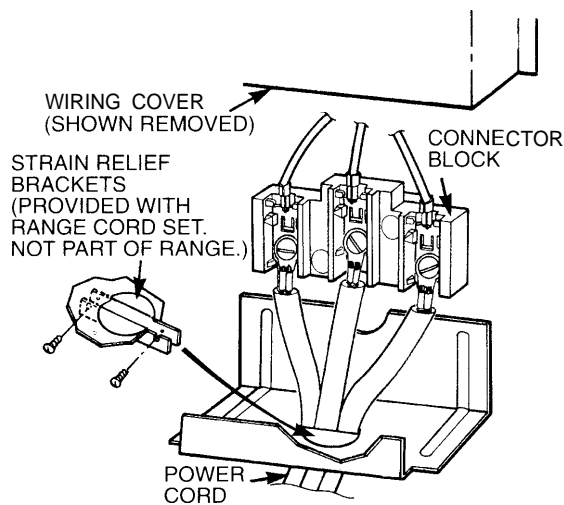

STEP 4

3-WIRE SYSTEM

Power Cord Installation-Insert screws through power cord terminals so that the screws pass through connector block terminals and engage nuts. Tighten screws securely.

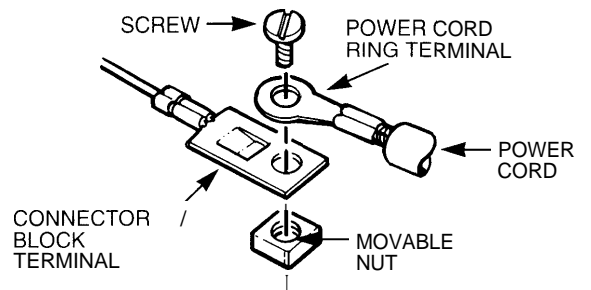

Cable Direct Installation-Clamp bare wires between the connector block terminals and movable nuts with screws tightened securely.

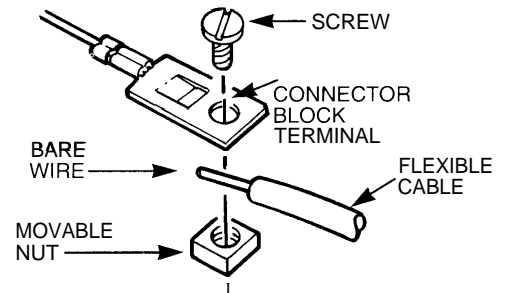

1. Copper Wiring

Connect the neutral or grounded wire of the supply circuit to the neutral terminal of the connector block, located in the center. The power leads must be connected to the outside (brass colored) terminals.

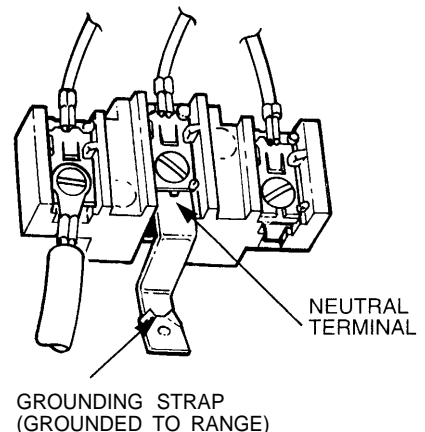

WARNING: CONNECTOR BLOCK IS APPROVED FOR COPPER WIRE CONNECTION ONLY.

2. Aluminum Wiring

A. Connect length of copper building wire to range terminal block.

B. Splice copper wires to aluminum wiring using special connectors designed and U.L. approved for joining copper to aluminum, and follow the connector manufacturer's recommended procedure closely.

NOTE: Wire used, location and enclosure of splices, etc., must conform to good wiring practice and local codes.

STEP 5

4-WIRE SYSTEM

SPECIAL GROUNDING INSTRUCTIONS

WARNING:

Frame grounded to neutral of appliance through a link. If used in a MOBILE HOME or if LOCAL CODES do not permit grounding through the neutral:

- 1) disconnect the link from neutral,
- 2) use grounding terminal or lead to ground unit in accordance with local codes, and
- 3) connect neutral terminal or lead to branch circuit in usual manner.

(If the appliance is to be connected by means of a cord set, use 4-conductor cord for this purpose.)

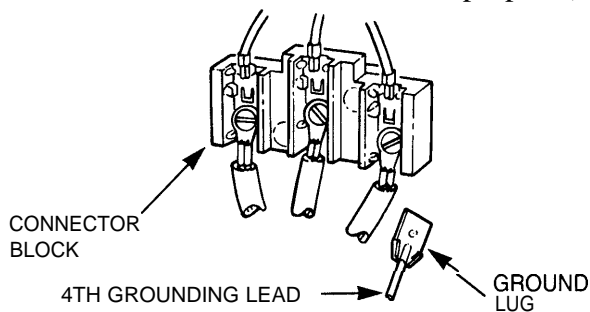

STEP 6

ANTI-TIP BRACKET INSTALLATION

AN ANTI-TIP bracket is supplied with instructions for installation in a variety of locations. The instructions include a template, a parts list and a list of tools necessary to complete the installation. Read the IMPORTANT SAFETY INSTRUCTIONS and the instructions that fit your situation before beginning installation.

WARNING

1. Range must be secured by ANTI-TIP bracket supplied.
2. See instructions to install (supplied with bracket).
3. Unless properly installed, range could be tipped by stepping or sitting on door. Injury might result from spilled hot liquids or from range itself.

Typical installation of Anti-Tip bracket

Attachment to *Wall*

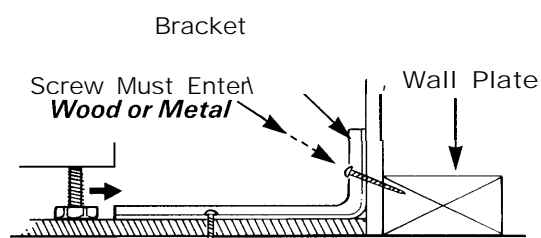

STEP 7

LEVELING THE RANGE

The range must be leveled. Leveling feet are located on each corner of the base of the range. Remove the storage drawer and rotate the leveling feet in or out as required. To remove drawer, pull it out all the way, tilt up the front and remove it. To replace, insert glides at back of drawer beyond stop on range glides. Lift drawer if necessary to insert easily.

One of the rear leveling feet will engage the ANTI-TIP bracket (allow for some side to side adjustment). Allow a minimum clearance of 1/8" between the range and the leveling foot that is to be installed into the ANTI-TIP bracket.

Check the range for proper installation into the ANTI-TIP bracket (after the range has been properly installed) by grasping the edges of the REAR burner holes and carefully attempting to tilt the range forward.

STEP 8

FINAL CHECK

Be sure all switches are in the "off" position before leaving the range.

Notes

Notes

We'll Be There

With the purchase of your new GE appliance, receive the assurance that if you ever need information or assistance from GE, we'll be there. All you have to do is call-toll-free!



In-Home Repair Service

**800-GE-CARES
(800-432-2737)**

A GE Consumer Service professional will provide expert repair service, scheduled at a time that's convenient for you. Many GE Consumer Service company-operated locations offer you service today or tomorrow, or at your convenience (7:00 a.m. to 7:00 p.m. weekdays, 9:00 a.m. to 2:00 p.m. Saturdays). Our factory-trained technicians know your appliance inside and out—so most repairs can be handled in just one visit.



Service Contracts

800-626-2224

You can have the secure feeling that GE Consumer Service will still be there after your warranty expires. Purchase a GE contract while your warranty is still in effect and you'll receive a substantial discount. With a multiple-year contract, you're assured of future service at today's prices.

Parts and Accessories

800-626-2002

Individuals **qualified** to service their own appliances can have needed parts or accessories sent directly to their home, free of shipping charge! The GE parts system provides access to over 47,000 parts . . . and all GE Genuine Renewal Parts are fully warranted. VISA, MasterCard and Discover cards are accepted.

User maintenance instructions contained in this booklet cover procedures intended to be performed by any user. Other servicing generally **should** be referred to qualified service personnel. Caution must be exercised, since improper servicing may cause unsafe operation.



GE Answer Center®

800.626.2000

Whatever your question about any GE major appliance, GE Answer Center® information service is available to help. Your call—and your question—will be answered promptly and courteously. And you can call any time. GE Answer Center® service is open 24 hours a day 7 days a week.

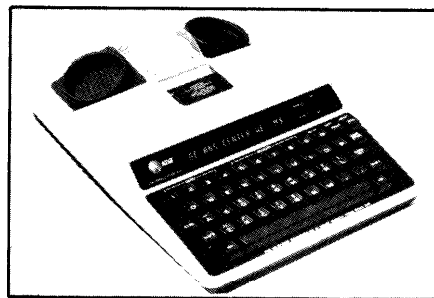

Telecommunication Device for the Deaf

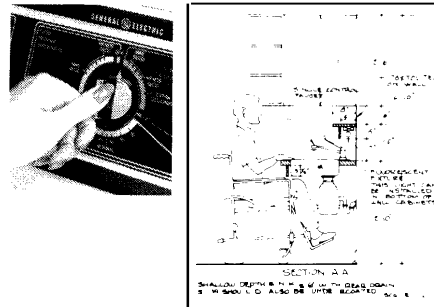

For Customers With Special Needs...

800.626.2000

Upon request, GE will provide Braille controls for a variety of GE appliances, and a brochure to assist in planning a barrier-free kitchen for persons with limited mobility. To obtain these items, free of charge, call 800.626.2000.

Consumers with impaired hearing or speech who have access to a TDD or a conventional teletypewriter may call 800-TDD-GEAC (800-833-4322) to request information or service.

YOUR GE ELECTRIC RANGE WARRANTY

Save proof of original purchase date such as your sales slip or cancelled check to establish warranty period

WHAT IS COVERED

FULL ONE-YEAR WARRANTY

For one year from date of original purchase, we will provide, free of charge, parts and service labor in your home to repair or replace **any part of the range** that fails because of a manufacturing defect.

This warranty is extended to the original purchaser and any succeeding owner for products purchased for ordinary home use in the 48 mainland states, Hawaii and Washington, D.C. In Alaska the warranty is the same except that it is LIMITED because you must pay to ship the product to the service shop or for the service technician's travel costs to your home.

All warranty service will be provided by our Factory Service Centers or by our authorized Customer Care[®] servicers during normal working hours.

Look in the White or Yellow Pages of your telephone directory for GENERAL ELECTRIC COMPANY, GENERAL ELECTRIC FACTORY SERVICE, GENERAL ELECTRIC-HOTPOINT FACTORY SERVICE or GENERAL ELECTRIC CUSTOMER CARE[®] SERVICE.

WHAT IS NOT COVERED

•Service trips to your home to teach you how to use the product.

Read your Use and Care material.

If you then have any questions about operating the product please contact your dealer or our Consumer Affairs office at the address below, or call, toll free:

GE Answer Center[™]
800.626.2000
consumer information service

•Improper installation.

If you have an installation problem, contact your dealer or installer. You are responsible for providing adequate electrical, gas, exhausting and other connecting facilities.

•Replacement of house fuses or resetting of circuit breakers.

•Failure of the product if it is used for other than its intended purpose or used commercially.

•Damage to product caused by accident, fire, floods or acts of God.

WARRANTOR IS *NOT* RESPONSIBLE FOR CONSEQUENTIAL DAMAGES.

Some states do not allow the exclusion or limitation of incidental or consequential damages, so the above limitation or exclusion may not apply to you. This warranty gives you specific legal rights, and you may also have other rights which vary from state to state. To know what your legal rights are in your state, consult your local or state consumer affairs office or your state's Attorney General.

Warrantor: General Electric Company

**If further help is needed concerning this warranty, write:
Manager—Consumer Affairs, GE Appliances, Louisville, KY 40225**

This book is printed on recycled paper.

Part No. 164D2588P051

Pub No. 49-8251

5-91 CG

JB450GP
JB550GP
JB551 GP