

# SHARP

## SERVICE MANUAL

KB-3425LS/K/W  
KB-4425LS/K/W

S66R264KB442L



KB-4425LW pictured

### FREE STANDING/SLIDE-IN RANGE WITH MICROWAVE DRAWER

### MODELS

<b>KB-3425LS</b>	<b>KB-4425LS</b>
<b>KB-3425LK</b>	<b>KB-4425LK</b>
<b>KB-3425LW</b>	<b>KB-4425LW</b>

#### WARNING TO SERVICE PERSONNEL:

This service manual is intended for use by persons having electrical and mechanical training and a level of knowledge of these subjects generally considered acceptable in the appliance repair trade. Sharp Electronics Corporation cannot be responsible, nor assume any liability, for injury or damage of any kind arising from the use of this manual.

Microwave ovens contain circuitry capable of producing very high voltage and current. Contact with the following parts may result in a severe, possibly fatal, electrical shock. (High Voltage Capacitor, High Voltage Power Transformer, High Voltage Rectifier and Heat sink etc., and Magnetron, High Voltage Harness etc..)

#### TABLE OF CONTENTS

	Page
PRECAUTIONS TO BE OBSERVED BEFORE AND DURING SERVICING TO AVOID POSSIBLE EXPOSURE TO EXCESSIVE MICROWAVE ENERGY.....	INSIDE FRONT COVER
BEFORE SERVICING.....	INSIDE FRONT COVER
WARNING TO SERVICE PERSONNEL.....	3
MICROWAVE MEASUREMENT PROCEDURE.....	5
FOREWORD AND WARNING.....	7
PRODUCT SPECIFICATIONS.....	8
POWER CONNECTION.....	10
ANTI-TIP DEVICE.....	12
CONTROL LAYOUT.....	13
SCHEMATICS.....	14
TEST PROCEDURES.....	18
TOUCH CONTROL PANEL ASSEMBLY.....	29
OVEN/MICROWAVE DRAWER DISASSEMBLY.....	40
WIRING DIAGRAMS.....	52
PRINTED WIRING BOARDS.....	58
PARTS LIST.....	63
PACKING AND ACCESSORIES.....	74

## SHARP ELECTRONICS CORPORATION

This document has been published to be used for after sales service only. The contents are subject to change without notice.

## **PRECAUTIONS TO BE OBSERVED BEFORE AND DURING SERVICING TO AVOID POSSIBLE EXPOSURE TO EXCESSIVE MICROWAVE ENERGY**

- (a) Do not operate or allow the oven to be operated with the door open.
- (b) Make the following safety checks on all ovens to be serviced before activating the magnetron or other microwave source, and make repairs as necessary: (1) interlock operation, (2) proper door closing, (3) seal and sealing surfaces (arcing, wear, and other damage), (4) damage to or loosening of hinges and latches, (5) evidence of dropping or abuse.
- (c) Before turning on microwave power for any service test or inspection within the microwave generating compartments, check the magnetron, wave guide or transmission line, and cavity for proper alignment, integrity, and connections.
- (d) Any defective or misadjusted components in the interlock, monitor, door seal, and microwave generation and transmission systems shall be repaired, replaced, or adjusted by procedures described in this manual before the oven is released to the owner.
- (e) A microwave leakage check to verify compliance with the Federal Performance Standard should be performed on each oven prior to release to the owner.

## **BEFORE SERVICING**

Before servicing an operative unit, perform a microwave emission check as per the Microwave Measurement Procedure outlined in this service manual.

If microwave emissions level is in excess of the specified limit, contact SHARP ELECTRONICS CORPORATION immediately @ 1-800-237-4277.

If the unit operates with the door open, service person should 1) tell the user not to operate the oven and 2) contact SHARP ELECTRONICS CORPORATION and Food and Drug Administration's Center for Devices and Radiological Health immediately.

Service personnel should inform SHARP ELECTRONICS CORPORATION of any certified unit found with emissions in excess of  $4\text{mW}/\text{cm}^2$ . The owner of the unit should be instructed not to use the unit until the oven has been brought into compliance.

## WARNING TO SERVICE PERSONNEL


Range units contain circuitry capable of producing very high voltage and current, contact with following parts may result in a severe, possibly fatal, electrical shock.

(Example)

High Voltage Capacitor, High Voltage Power Transformer, Magnetron, High Voltage Rectifier Assembly, High Voltage Harness, Heating Elements, etc..

Read the Service Manual carefully and follow all instructions.

### Before Servicing

1. Disconnect the power supply cord , and then remove cabinet.
2. Open the drawer and keep it open.
3. Discharge high voltage capacitor.

**WARNING: RISK OF ELECTRIC SHOCK.  
DISCHARGE THE HIGH-VOLTAGE  
CAPACITOR BEFORE SERVICING.**

The high-voltage capacitor remains charged about 60 seconds after the oven has been switched off. Wait for 60 seconds and then short-circuit the connection of the high-voltage capacitor (that is the connecting lead of the high-voltage rectifier) against the chassis with the use of an insulated screwdriver.

Whenever troubleshooting is performed the power supply must be disconnected. It may, in some cases, be necessary to connect the power supply after the outer case has been removed, in this event:

1. Disconnect the power supply cord, and then remove necessary covers.
2. Open the drawer and keep it open.
3. Discharge high voltage capacitor.
4. Disconnect the leads to the primary of the power transformer.
5. Ensure that the leads remain isolated from other components and oven chassis by using insulation tape.
6. After that procedure, reconnect the power supply cord.

### When the testing is completed,

1. Disconnect the power supply cord, and then remove covers.
2. Open the drawer and keep it open.
3. Discharge high voltage capacitor.
4. Reconnect the leads to the primary of the power transformer.
5. Reinstall the covers.
6. Reconnect the power supply cord.
7. Run the unit and check all functions.

### After repairing

1. Reconnect all leads removed from components during testing.
2. Reinstall the covers.
3. Reconnect the power supply cord.
4. Run the oven and check all functions.

Microwave ovens should not be operated empty. To test for the presence of microwave energy within a cavity, place a cup of cold water on the oven tray, close the drawer and set the power to HIGH and set the microwave timer for two (2) minutes. When the two minutes has elapsed (timer at zero) carefully check that the water is now hot. If the water remains cold carry out **Before Servicing** procedure and re-examine the connections to the component being tested.

When all service work is completed and the oven is fully assembled, the microwave power output should be checked and a microwave leakage test should be carried out.

## SAFE SERVICING PRACTICES

To avoid personal injury and/or property damage, it is important that Safe Servicing Practices be observed. The following are some limited examples of safe practices:

1. DO NOT attempt a product repair if you have any doubts as to your ability to complete it in a safe and satisfactory manner.
2. Before servicing or moving an appliance:
  - Remove the power cord from the electrical outlet, trip the circuit breaker to the OFF position, or remove the fuse.
3. Never interfere with the proper operation of any safety device.
4. USE ONLY REPLACEMENT PARTS CATALOGED FOR THIS APPLIANCE. SUBSTITUTIONS MAY DEFEAT COMPLIANCE WITH SAFETY STANDARDS SET FOR HOME APPLIANCES.
5. GROUNDING : The standard color coding for safety ground wires is GREEN , or GREEN with YELLOW STRIPES . Ground leads are not to be used as current carrying conductors. It is EXTREMELY important that the service technician reestablish all safety grounds prior to completion of service. Failure to do so will create a hazard.
6. Prior to returning the product to service, ensure that:
  - All electrical connections are correct and secure
  - All electrical leads are properly dressed and secured away from sharp edges, high-temperature components, and moving parts
  - All non-insulated electrical terminals, connectors, heaters, etc. are adequately spaced away from all metal parts and panels
  - All safety grounds (both internal and external) are correctly and securely connected
  - All panels are properly and securely reassembled

### ATTENTION!!!

**This service manual is intended for use by persons having electrical and mechanical training and a level of knowledge of these subjects generally considered acceptable in the appliance repair trade. Sharp Electronics Corporation cannot be responsible, nor assume any liability, for injury or damage of any kind arising from the use of this manual.**

## MICROWAVE MEASUREMENT PROCEDURE

### A. Requirements:

- 1) Microwave leakage limit (Power density limit): The power density of microwave radiation emitted by a microwave oven should not exceed  $1\text{mW}/\text{cm}^2$  at any point 5cm or more from the external surface of the oven, measured prior to acquisition by a purchaser, and thereafter (through the useful life of the oven),  $5\text{mW}/\text{cm}^2$  at any point 5cm or more from the external surface of the oven.
- 2) Safety interlock switches:  
Primary interlock relay switch shall prevent microwave radiation emission in excess of the requirement as above mentioned. Secondary interlock relay and door sensing switch shall prevent microwave radiation emission in excess of  $5\text{mW}/\text{cm}^2$  at any point 5cm or more from the external surface of the oven.

### B. Preparation for testing:

#### Before beginning the actual measurement of leakage, proceed as follows:

- 1) Make sure that the actual instrument is operating normally as specified in its instruction booklet.

#### Important:

Survey instruments that comply with the requirement for instrumentation as prescribed by the performance standard for microwave ovens, 21 CFR 1030.10(c)(3)(i), must be used for testing.

- 2) Place the load of  $275\pm 15$  ml (9.8 oz) of tap water initially at  $20\pm 5^\circ\text{C}$  ( $68^\circ\text{F}$ ) in the center of the oven cavity.  
The water container shall be a low form of 600 ml (20 oz) beaker with an inside diameter of approx. 8.5 cm (3-1/2 in.) and made of an electrically nonconductive material such as glass or plastic.  
The placing of this standard load in the oven is important not only to protect the oven, but also to insure that any leakage is measured accurately.
- 3) Set the cooking control on Full Power Cooking Mode.
- 4) Close the drawer and select a cook cycle of several minutes. If the water begins to boil before the survey is completed, replace it with 275 ml of cool water.

### C. Leakage test:

#### Closed-drawer leakage test (microwave measurement):

- 1) Grasp the probe of the survey instrument and hold it perpendicular to the gap between the drawer and the body of the oven.
- 2) Move the probe slowly, not faster than 1 in./sec. (2.5 cm/sec.) along the gap, watching for the maximum indication on the meter.
- 3) Check for leakage at the drawer screen, sheet metal seams and other accessible positions where the continuity of the metal has been breached (eg., around the switches, indicator, and vents).  
While testing for leakage around the drawer, pull the drawer away from the front of the oven as far as is permitted by the closed latch assembly.
- 4) Measure carefully at the point of highest leakage and make sure that the highest leakage is no greater than  $4\text{mW}/\text{cm}^2$ , and that the primary interlock switch/secondary interlock relay does turn the oven OFF before any door movement.

## NOTES

# SERVICE MANUAL

## SHARP

FREE STANDING /SLIDE-IN RANGE  
WITH MICROWAVE DRAWER

KB-3425LS / KB-3425LK / KB-3425LW  
KB-4425LS / KB-4425LK / KB-4425LW

### FOREWORD

This Manual has been prepared to provide Sharp Electronics Corp. Service Personnel with Operation and Service Information for the SHARP FREE STANDING and SLIDE-IN RANGE WITH MICROWAVE DRAWER, KB-3425LS/JK/JW and KB-4425LS/JK/JW

It is recommended that service personnel carefully study the entire text of this manual so that they will be qualified to render satisfactory customer service.

Check the interlock switches and the door seal carefully. Special attention should be given to avoid electrical shock and microwave radiation hazard.

#### WARNING

Never operate the oven until the following points are ensured.

- (A) The door is tightly closed.
- (B) The door brackets and hinges are not defective.
- (C) The door packing is not damaged.
- (D) The door is not deformed or warped.
- (E) There is not any other visible damage with the oven.

Servicing and repair work must be carried out only by trained service personnel.

#### DANGER

**Certain initial parts are intentionally not grounded and present a risk of electrical shock only during servicing. Service personnel - Do not contact the following parts while the appliance is energized;**

**High Voltage Capacitor, Power Transformer, Magnetron, High Voltage Rectifier Assembly, High Voltage Harness;  
If provided, Vent Hood, Fan assembly, Cooling Fan Motor.**

All the parts marked "\*" on parts list are used at voltages more than 250V.

Removal of the outer wrap gives access to voltage above 250V.

All the parts marked "Δ" on parts list may cause undue microwave exposure, by themselves, or when they are damaged, loosened or removed.

PRODUCT DESCRIPTION

POWER CONNECTION  
ANTI-TIP DEVICE

SCHEMATICS

TEST PROCEDURE

TOUCH CONTROL PANEL

COMPONENT REPLACEMENT  
AND ADJUSTMENT PROCEDURE

WIRING DIAGRAM

PARTS LIST

SHARP ELECTRONICS CORPORATION

SHARP PLAZA, MAHWAH,  
NEW JERSEY 07430-2135

## OVEN SPECIFICATION

ITEM	DESCRIPTION
Power Requirements	120 /208 - 120/240Volts / 46/50 Amperes 60 Hertz Single phase, 3 wire grounded
Thermal Oven Heating Elements	Top - 3000W Bottom - 3000W Rear - 2500W
Case Dimensions	Width 29-7/8" Height 36" Depth 27-7/8"
Cooking Cavity Dimensions 3.6 Cubic Feet	Width 22-5/8" Height 15-13/16" Depth 18"
Cook Top Heating Elements	Two 6" - 1200W One 8" - 2000W One 6"/9" - 1200/2400W One 6" - 100W
Control Complement	Touch Navigation System Clock ( 1:00 - 12:59 ) Timer (0 - 99 min. 99 seconds)  Kitchen Timer, Cooktop Warm, Stop/Clear, Oven Light, Start, LOWER OVEN
Oven Cavity Light	40W x 1
Safety Standard	UL Listed
Weight	Approx. 260 lbs.



## MICROWAVE DRAWER SPECIFICATION

ITEM	DESCRIPTION
Power Output	1000 watts (IEC TEST PROCEDURE) Operating frequency of 2450MHz
Cooking Cavity Dimensions 1.0 Cubic Feet	Width 17-11/32 Height 5-7/8" Depth 17-1/8"
Control Complement	Touch Navigation System Clock ( 1:00 - 12:59 ) Timer (0 - 99 min. 99 seconds) Microwave Power for Variable Cooking Repetition Rate; P-HI ..... Full power throughout the cooking time P-90..... approx. 90% of Full Power P-80..... approx. 80% of Full Power P-70..... approx. 70% of Full Power P-60..... approx. 60% of Full Power P-50..... approx. 50% of Full Power P-40..... approx. 40% of Full Power P-30 ..... approx. 30% of Full Power P-20..... approx. 20% of Full Power P-10..... approx. 10% of Full Power P-0..... No power throughout the cooking time  Kitchen Timer, Cooktop Warm, Stop/Clear, Oven Light, Start, LOWER OVEN, Start/ Minute Plus, UPPER MICROWAVE OVEN, OPEN, CLOSE.
Oven Cavity Light	Yes
Safety Standard	UL Listed                      FCC Authorized DHHS Rules, CFR, Title 21, Chapter 1, Subchapter J

## POWER CONNECTION

### 208/240 VOLT CONNECTION INSTRUCTIONS

The range can be set for 208V or 240V. The voltage setting for your range is pre-set at 240V from the factory. Follow these steps to change the voltage setting.

- 1 Locate the voltage switch on the lower back side of the range.
- 2 Remove the screw and rotate the switch plate 180° as indicated in the Figure 3.
- 3 Reinsert the switch plate and replace screw as indicated in Figure 4. The voltage setting is indicated by the visible marking.

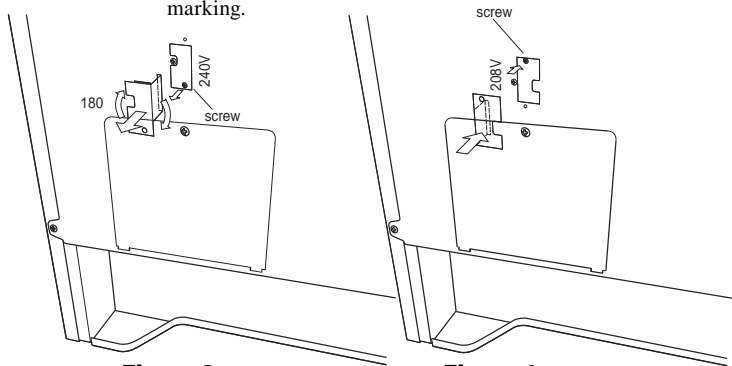


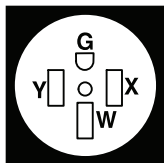
Figure 3

Figure 4

### 3 & 4-WIRE ELECTRICAL WALL RECEPTACLE TYPES & RECOMMENDED MOUNTING ORIENTATION ON WALL

Figure 5A illustrates 4-wire receptacle required for new and remodeled installations.

Figure 5B illustrates 3-wire receptacle that is allowed for existing installations.



4-wire wall receptacle (14-50R)  
Figure 5A



3-wire wall receptacle (10-50R)  
Figure 5B

### ACCESS TO TERMINAL BLOCK

Loosen screw on rear access cover and pull down as illustrated in Figure 6 to access terminal block wiring connection. To close, return to original location and secure screw.

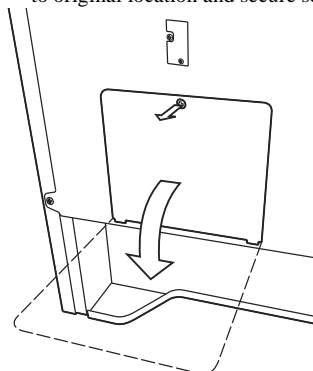


Figure 6

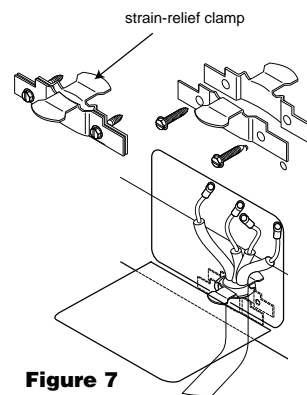


Figure 7

## POWER CORD CONNECTIONS

### 4-WIRE CONNECTION INSTRUCTIONS-FIGURE 8

Before wiring the range, review the suggested power source location. If connecting to a 4-wire electrical system for a new branch-circuit or mobile home use a 4-wire connection.

- 1 Follow the power supply kit manufacturer's Installation Instructions supplied with the strain relief clamp and install. See Figure 7.
- 2 Insert the end connectors for line 1, line 2 and neutral and tighten securely to the terminal block.
 

**IMPORTANT** DO NOT LOOSEN the factory installed nut connections which secure the range wiring to the terminal block. Electrical failure or loss of electrical connection may occur if these 3 nuts are loosened or removed.
- 3 You must disconnect the ground strap. Remove the factory installed ground screw and plate to release the copper ground strap from the frame of the range. Cut and discard the copper ground strap and plate. KEEP the ground screw.
- 4 Connect the green ground wire lead with the eyelet to the frame of the range with the ground screw using the same hole in the frame where the ground screw was originally installed. See Figure 8.
- 5 Make sure all screws are tightened securely and replace the rear access cover. See Figure 6.

### 3-WIRE CONNECTION INSTRUCTIONS

For existing installations ONLY, refer to Figure 9.

- 1 Follow the power supply kit manufacturer's Installation Instructions supplied with the strain relief clamp and install. See Figure 7.
- 2 Insert the end connectors for line 1, line 2 and neutral and tighten securely to the terminal block. See Figure 7.
 

**IMPORTANT** DO NOT LOOSEN the factory installed nut connections which secure the range wiring to the terminal block. Electrical failure or loss of electrical connection may occur if these 3 nuts are loosened or removed.

- 3 Make sure all connections are tightened securely and replace the rear access cover. See Figure 7.

**GROUNDING INSTRUCTIONS- ONLY 3-WIRE CONNECTIONS:**

A ground strap is installed on this range which connects the center terminal of the neutral terminal block to the range chassis. The ground strap is connected to the range by the center, lowest screw See Figure 9. The ground strap must not be removed unless National State or Local Codes do not permit use of a ground strap.

**Note:** If the ground strap is removed for any reason, a separate ground wire must be connected to the separate ground screw attached to the range chassis and to an adequate ground source

**3 & 4-WIRE PERMANENT WIRE CONNECTIONS**

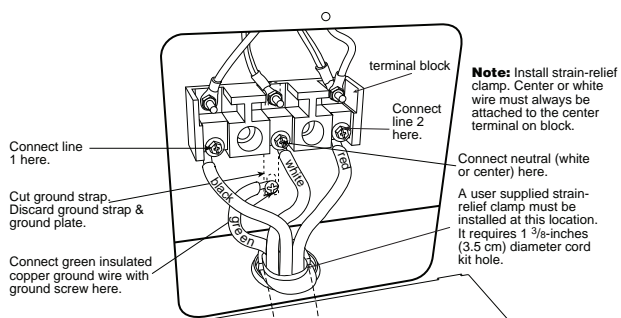
3-wire permanent connection – follow steps 1, 2 and 5 below.

4-wire permanent connection – follow all steps below.

Before wiring the range, review the suggested power source location drawings in Figure 2. If connecting to a 4-wire electrical system:

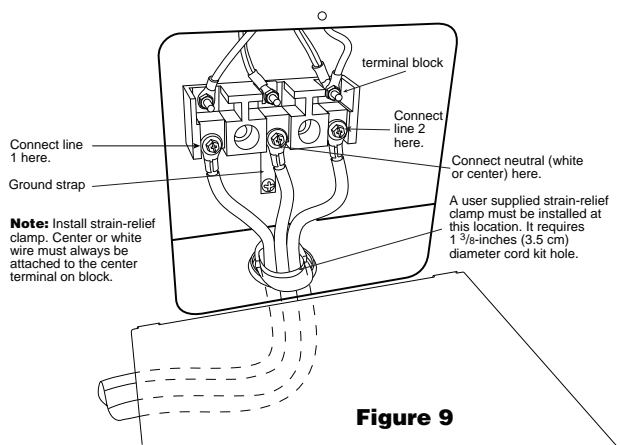
- 1 Follow the manufacturer s Installation Instructions supplied with the strain relief clamp and install.
- 2 Strip insulation away from the ends of the permanent wiring for line 1, line 2 and neutral; also strip ground wire on 4-wire

**4-WIRE CONNECTION**



**Figure 8**

**3-WIRE CONNECTION**



**Figure 9**

connections. Tighten all 3 or 4-wire leads to the terminal block. Follow wire locations shown in Figure 10.

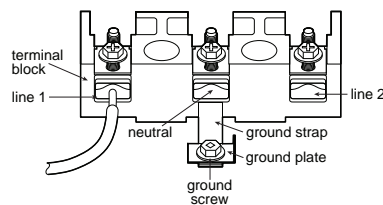
**IMPORTANT** DO NOT LOOSEN the factory installed nut connections which secure the range wiring to the terminal block. Electrical failure or loss of electrical connection may occur if these 3 nuts are loosened or removed.

**Note:** For 3-wire permanent connection skip steps 3 and 4 and continue with step 5.

- 3 Disconnect the ground strap. Remove the factory installed ground screw and plate to release the factory installed copper ground strap from frame of the range. Cut and discard the copper strap from the terminal block. KEEP the ground screw, ground plate and go to step 4.
- 4 Connect the green ground wire lead to the frame of the range using the ground screw and plate as shown in Figure 11. Be sure to install using the same hole in the frame where the ground screw was originally installed.
- 5 Make sure all connections are tightened securely and replace the rear access cover. See Figure 7.

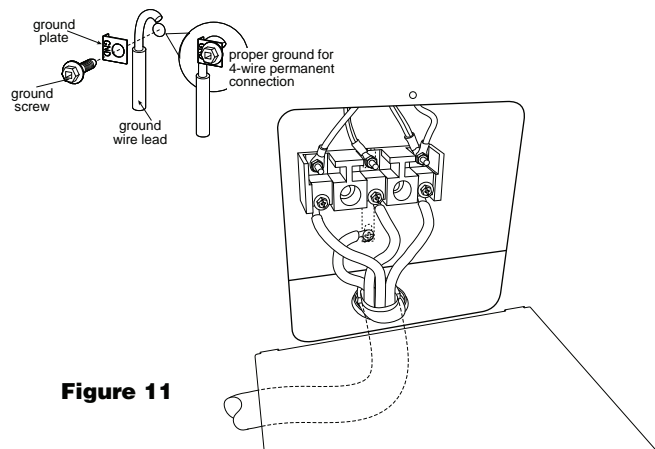
**Note:** Non-terminated field wire compression connections must be set at approximately 90 in./lbs.

**FOR 3 & 4-WIRE PERMANENT CONNECTIONS**



**Figure 10**

**4-WIRE PERMANENT CONNECTION ONLY**



**Figure 11**

## ANTI-TIP DEVICE

### NORMAL INSTALLATION STEPS

#### ANTI-TIP BRACKET INSTALLATION INSTRUCTIONS IMPORTANT SAFETY WARNING

To reduce the risk of tipping of the range, the range must be secured to the floor by properly installed Anti-Tip bracket and screws packed with the range. Failure to install the Anti-Tip bracket will allow the range to tip over if excessive weight is placed on an open door or if a child climbs upon it. Serious injury might result from spilled hot liquids or from the range itself.

If range is ever moved to a different location, the Anti-Tip bracket must also be moved and installed with the range. Instructions are provided for installation in wood or cement fastened to either the floor or wall. When installed to the wall, make sure that screws completely penetrate dry wall and are secured in wood or metal. When fastening to the floor or wall, be sure that screws do not penetrate electrical wiring or plumbing.

#### 1 LOCATE THE BRACKET - USING THE TEMPLATE

The bracket may be located on either the left or right side of the range. Use the information below to locate the bracket if template is not available.

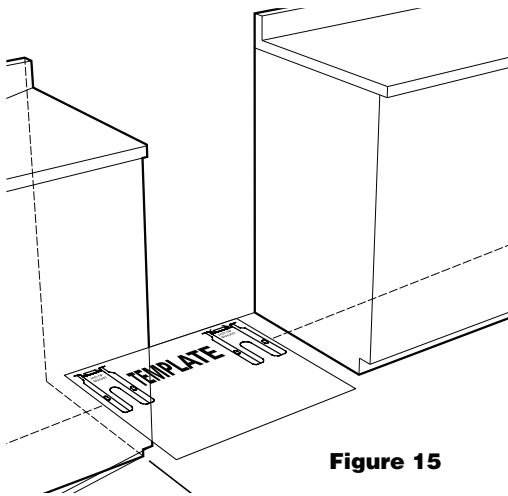


Figure 15

Mark the floor or wall where left or right side of the range will be located. If rear of range is against the wall or no further than 1 1/4-inches from wall when installed, you may use the wall or floor mount method. If molding is installed and does not allow the bracket to fit push against the wall, remove molding or mount bracket to the floor. For wall mount, locate the bracket by placing the back edge of the template against the rear wall and the side edge of template on the mark made referencing the side of the range. Place bracket on top of template and mark location of the screw holes in wall. If rear of range is further than 1 1/4-inches from the wall when installed, attach bracket to the floor. For floor mount, locate the bracket by placing back edge of the template where the rear of the range will be located. Mark the location of the screw holes, shown in template.

#### 2 DRILL PILOT HOLES AND FASTEN BRACKET

Drill a 1/8-inch pilot hole where screws are to be located. If bracket is to be mounted to the wall, drill pilot hole at an approximate 20 degree downward angle. If bracket is to be mounted to masonry or ceramic floors, drill a 5/32-inch pilot hole 1 3/4-inches deep. The screws provided may be used in wood or concrete material. Use a 5/16-inch nut-driver or flat head screwdriver to secure the bracket in place.

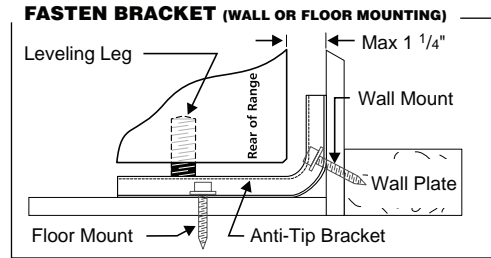


Figure 16

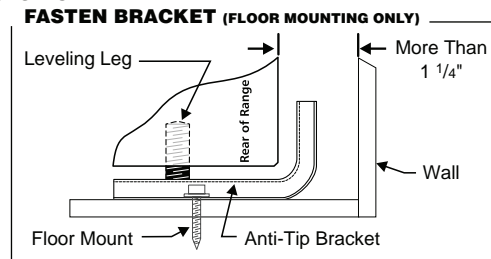


Figure 17

#### 3 LEVEL AND POSITION RANGE

Level range by adjusting the (4) leveling legs with a wrench. Note: A minimum clearance of 1/8-inch is required between the bottom of the range and the leveling leg to allow room for the bracket. Use a level to check your adjustments. Plug range into properly prepared electrical receptacle or if hard wired, check that it was completed properly. Check door condition for evenness and stability. Slide range back into position.

Visually check that rear leveling leg is inserted into and fully secured by the Anti-Tip bracket by looking underneath the range with a flashlight and carefully attempt to tilt it forward.

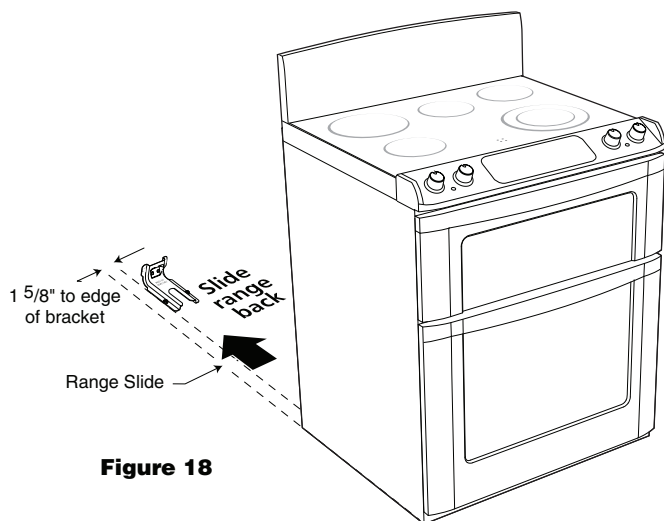
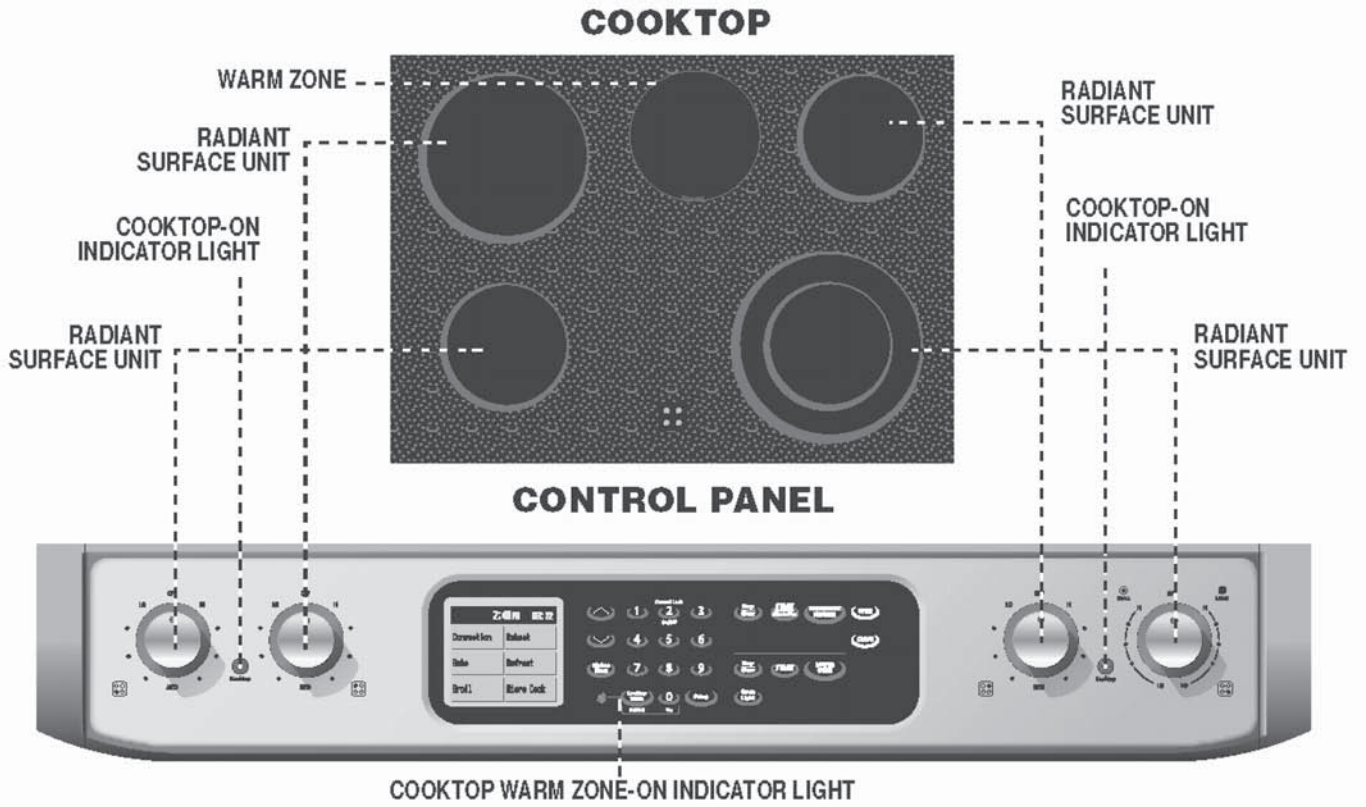


Figure 18

KB-3425L Shown

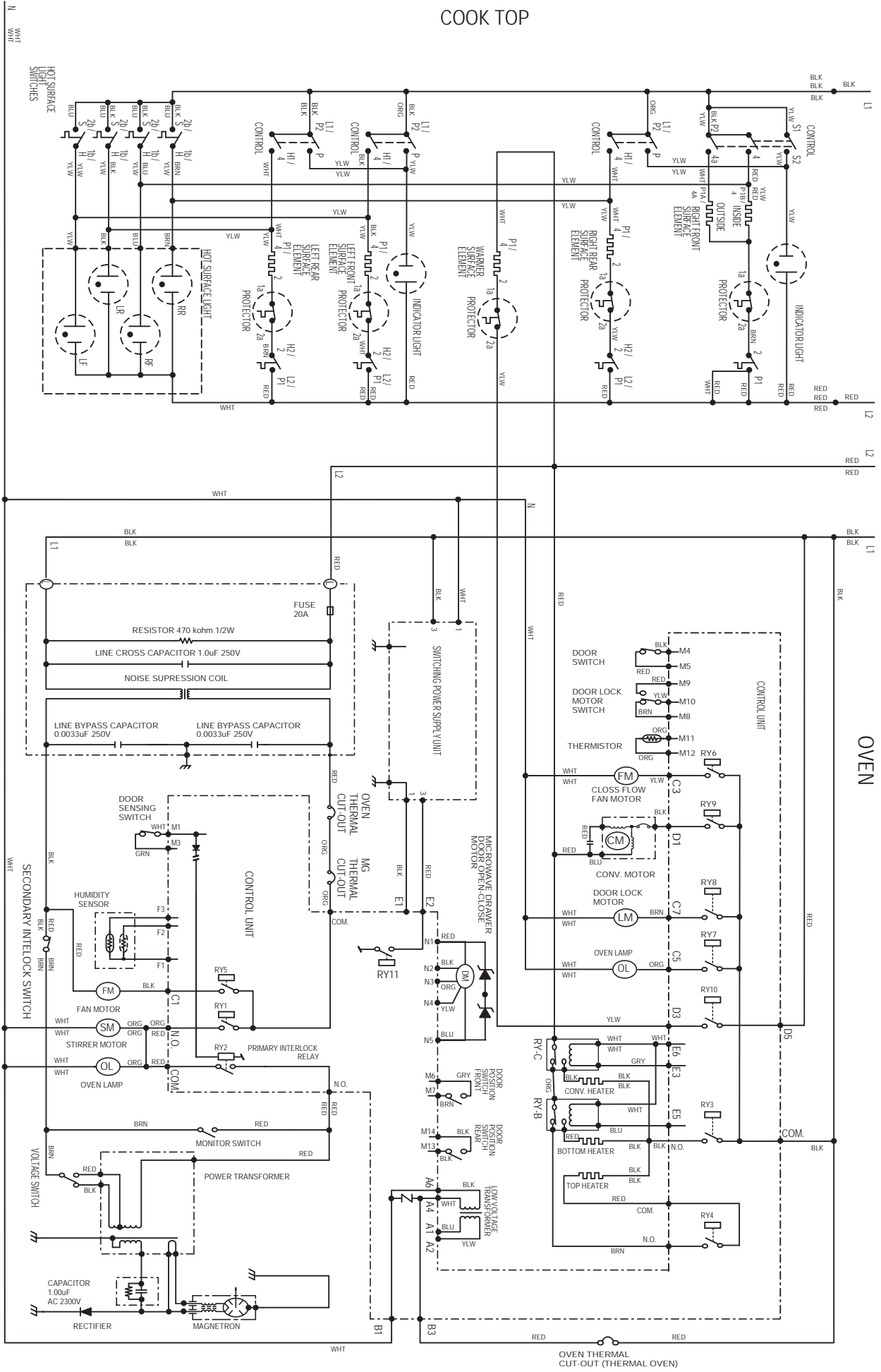


### KEYSHEET



Schematic-Off Condition

COOK TOP



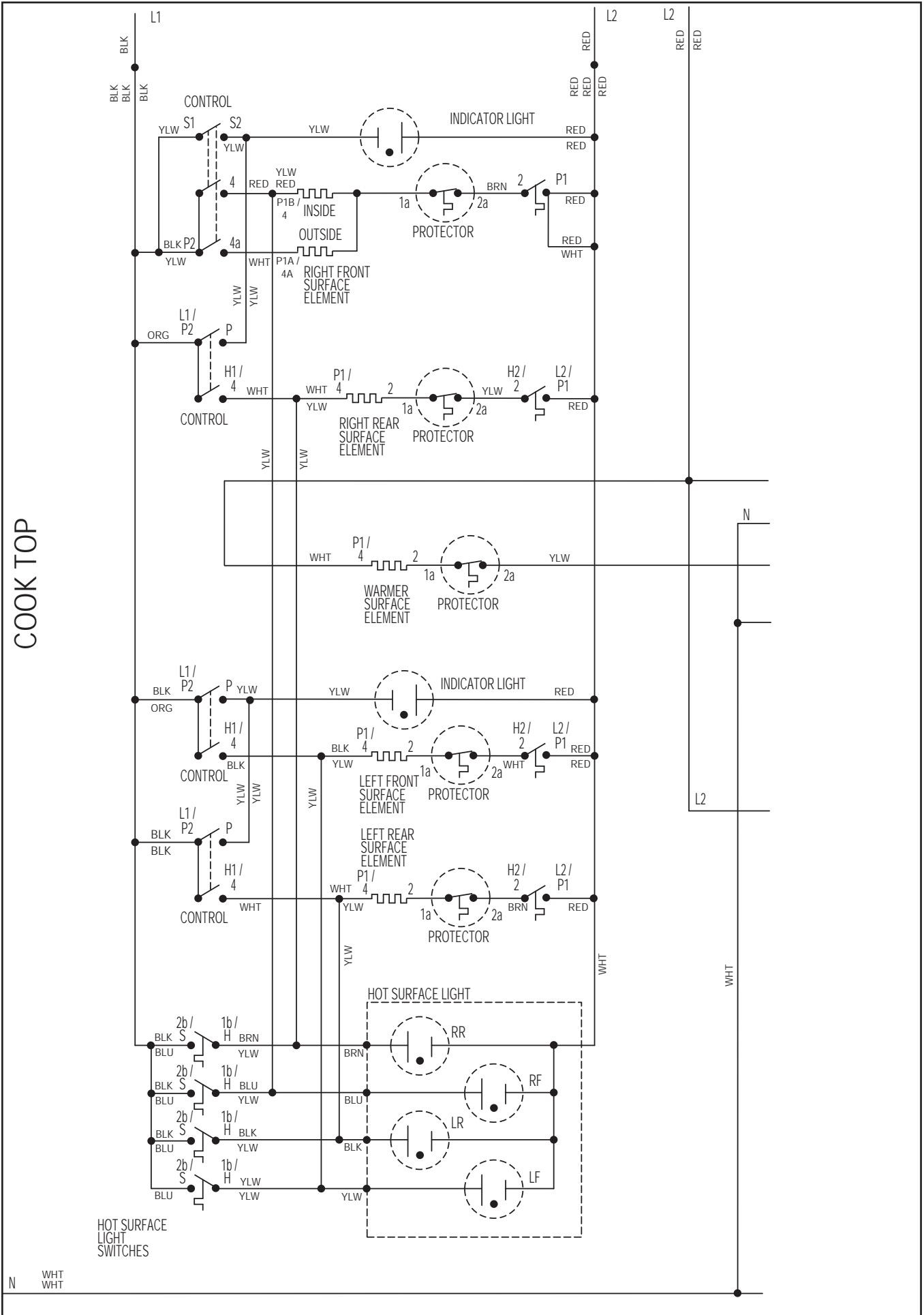
- NOTES:
1. Circuits / wire colors are subject to change without notice.
  2. Terminal that is located on the right side on lamp sockets back view must be connected to neutral wire.

MICROWAVE DRAWER

# COOK TOP SCHEMATIC (DETAIL)

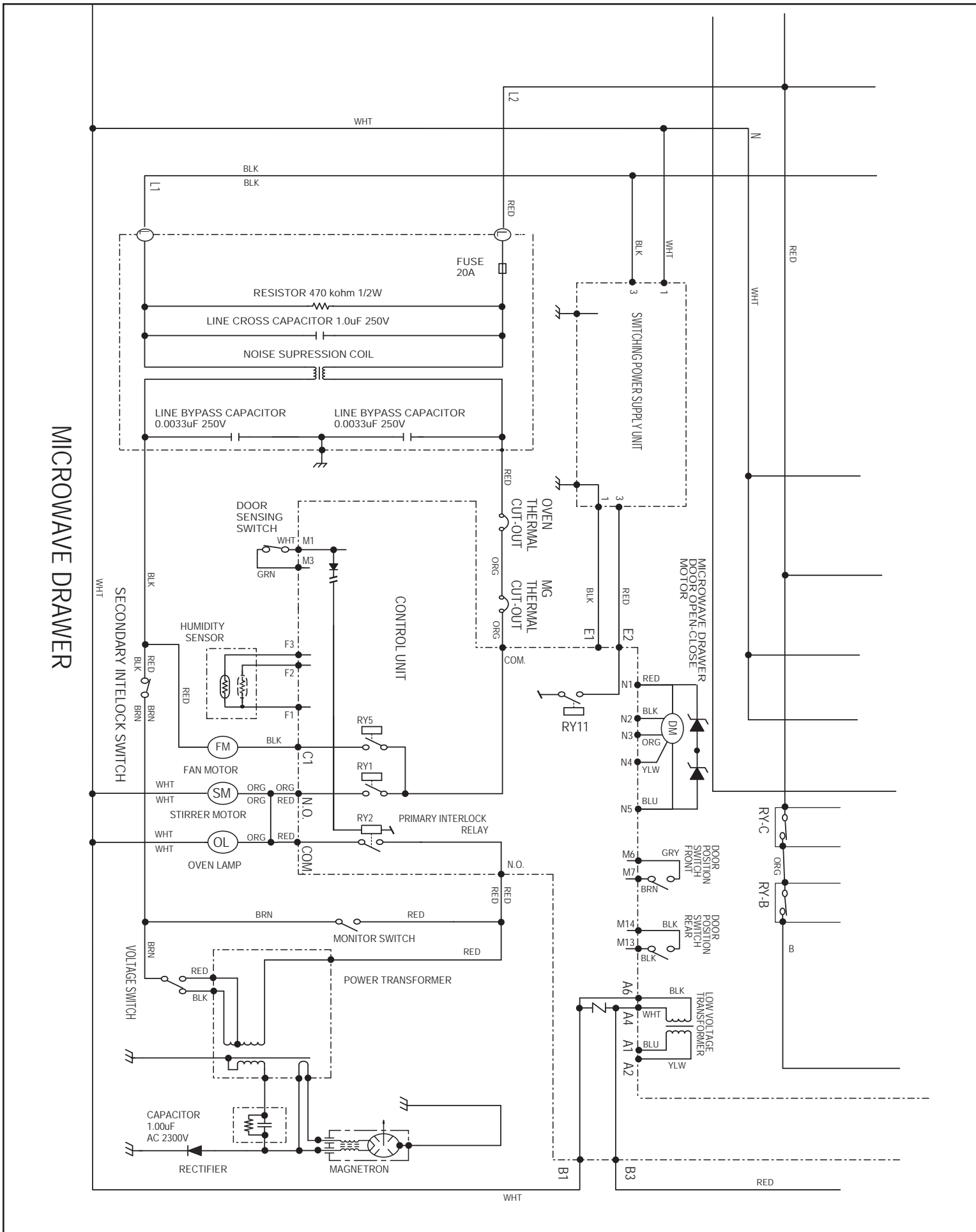
KB-3425LS/K/W  
KB-4425LS/K/W

COOK TOP



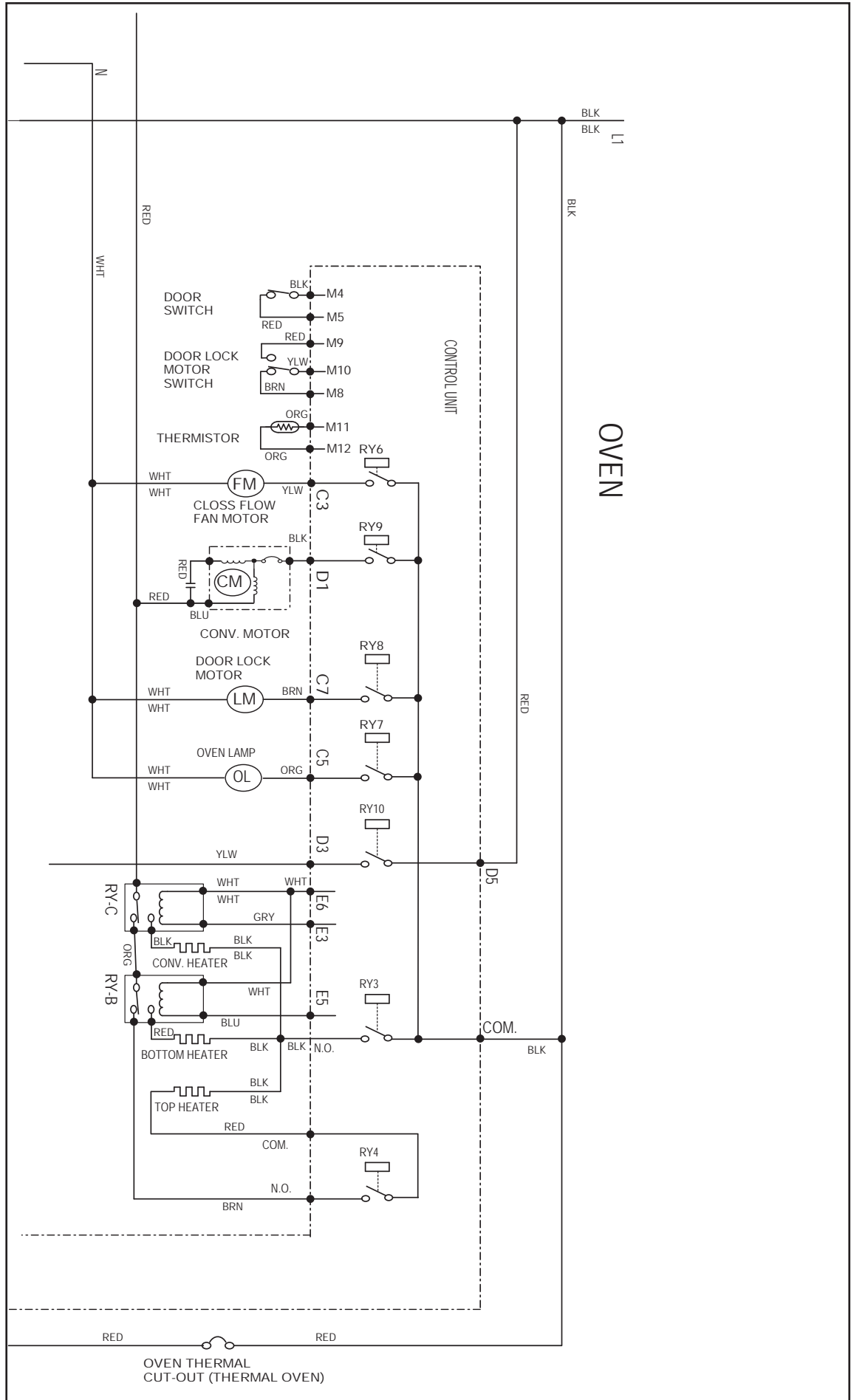
N WHT  
WHT

# MICROWAVE DRAWER SCHEMATIC (DETAIL)





# RANGE SCHEMATIC (DETAIL)



PROCEDURE LETTER	COMPONENT TEST
A	<p data-bbox="300 157 828 189"><b>TOUCH CONTROL PANEL ASSEMBLY TEST</b></p> <p data-bbox="300 199 1485 294">The touch control panel consists of circuits including semiconductors such as LSI, ICs, etc. Therefore, unlike conventional microwave ovens, proper maintenance cannot be performed with only a voltmeter and ohmmeter.</p> <p data-bbox="300 304 1485 388">In this service manual, the touch control panel assembly is divided into three units, Control Unit and Keyboard Unit and Power Unit, and troubleshooting by unit replacement is described according to the symptoms indicated.</p> <p data-bbox="300 399 487 430"><b>Before testing,</b></p> <ol data-bbox="341 430 1485 640" style="list-style-type: none"><li>1) Disconnect the power supply cord, and then disassemble as per "OVEN/MICROWAVE DRAWER DISASSEMBLY" page 40.</li><li>2) Open the drawer and block it open.</li><li>3) Discharge high voltage capacitor.</li><li>4) Disconnect the leads to the primary of the power transformer.</li><li>5) Ensure that these leads remain isolated from other components and oven chassis by using insulation tape.</li></ol> <p data-bbox="300 651 511 682">1. Keyboard Unit.</p> <p data-bbox="341 682 430 714">NOTE ;</p> <ol data-bbox="341 714 1144 871" style="list-style-type: none"><li>1) Check Keyboard unit connection before replacement.</li><li>2) Reconnect all leads removed from components during testing.</li><li>3) Re-install the outer case (cabinet).</li><li>4) Reconnect the power supply cord after the outer case is installed.</li><li>5) Run the oven and check all functions.</li></ol> <p data-bbox="373 871 1063 903">The following symptoms indicate a defective keyboard unit.</p> <ol data-bbox="341 903 1136 997" style="list-style-type: none"><li>a) When touching the pads, a certain pad produces no signal at all.</li><li>b) When touching a number pad, two figures or more are displayed.</li><li>c) When touching the pads, sometimes a pad produces no signal.</li></ol> <p data-bbox="341 997 714 1029">If the Keyboard unit is defective.</p> <ol data-bbox="341 1029 1144 1281" style="list-style-type: none"><li>1) Disconnect the power supply cord, and then remove outer case.</li><li>2) Open the door and block it open.</li><li>3) Discharge high voltage capacitor.</li><li>4) Replace the Keyboard unit.</li><li>5) Reconnect all leads removed from components during testing.</li><li>6) Re-install the covers.</li><li>7) Reconnect the power supply cord after the outer case is installed.</li><li>8) Run the oven and check all functions.</li></ol> <p data-bbox="300 1291 479 1323">2. Control Unit</p> <p data-bbox="341 1323 1485 1375">The following symptoms indicate a defective control unit. Before replacing the control unit, perform the Keyboard unit test (Procedure J) to determine if control unit is faulty.</p> <p data-bbox="300 1386 690 1417">2-1 In connection with indicators</p> <ol data-bbox="341 1417 1364 1627" style="list-style-type: none"><li>a) At a certain digit, all or some segments do not light up.</li><li>b) At a certain digit, brightness is low.</li><li>c) Only one indicator does not light.</li><li>d) The corresponding segments of all digits do not light up; or they continue to light up.</li><li>e) Wrong figure appears.</li><li>f) A certain group of indicators do not light up.</li><li>g) The figure of all digits flicker.</li></ol> <p data-bbox="300 1638 1023 1669">2-2 Other possible problems caused by defective control unit.</p> <ol data-bbox="341 1669 925 1764" style="list-style-type: none"><li>a) Buzzer does not sound or continues to sound.</li><li>b) Clock does not operate properly.</li><li>c) Cooking is not possible.</li></ol> <p data-bbox="300 1764 820 1795">3. Power Unit or Touch Control Transformer</p> <ol data-bbox="341 1795 1380 1858" style="list-style-type: none"><li>a) Fan motor, stirrer motor, oven lamp or electrical parts do not turn on or do not turn off.</li><li>b) Digital display on the control unit does not show anything.</li></ol> <p data-bbox="300 1858 625 1890">When testing is completed,</p> <ol data-bbox="341 1890 1485 2016" style="list-style-type: none"><li>1) Disconnect the power supply cord, and then disassemble as per "OVEN/MICROWAVE DRAWER DISASSEMBLY" page 40.</li><li>2) Open the drawer and block it open.</li><li>3) Discharge high voltage capacitor.</li></ol>

**TEST PROCEDURES**

PROCEDURE LETTER	COMPONENT TEST
------------------	----------------

- 4) Reconnect all leads removed from components during testing.
- 5) Re-install the covers.
- 6) Reconnect the power supply cord after the outer case is installed.
- 7) Run the oven and check all functions.

**B      KEYBOARD UNIT TEST**

1. Disconnect the power supply cord, and then disassemble as per "OVEN/MICROWAVE DRAWER DISASSEMBLY" page 40.
2. Open the drawer and block it open.
3. Discharge high voltage capacitor.
4. If the display fails to clear when the STOP/CLEAR pad is depressed, first verify the wire harness and connectors are making good contact between the control unit and the keyboard, verify that the door sensing switch operates properly; that is the contacts are closed when the door is closed and open when the door is open.
5. Remove the old keyboard unit and install the new keyboed unit (as the normal keyboard unit).
6. Reconnect the wire harness to the keyboard unit.
7. If the control unit responds by clearing with a beep when the stop/clear pad is touched, the old keyboard unit is faulty and must be replaced. If the control unit does not respond, it is faulty and must be replaced. If a specific pad does not respond, the above method may be used (after clearing the control unit) to determine if the control unit or keyboed unit is at fault.
8. Reconnect all leads removed from components during testing.
9. Re-install the covers.
10. Reconnect the power supply cord after the outer case is installed.
11. Run the oven and check all functions.

**C      RELAY TEST**

1. Disconnect the power supply cord, and then disassemble as per "OVEN/MICROWAVE DRAWER DISASSEMBLY" page 40.
2. Open the drawer and block it open.
3. Discharge high voltage capacitor.
4. Disconnect the leads to the primary of the power transformer.
5. Ensure that these leads remain isolated from other components and oven chassis by using insulation tape.
6. After that procedure, re-connect the power supply cord.
7. Remove the covers and check voltage between Pin Nos. 1 and 3 of the 2 pin connector (CN-B) on the power unit with an A.C. voltmeter.

The meter should indicate 116 or 120 volts, if not check oven circuit.

**RY1 and RY2 Relay Test**

These relays are operated by D.C. voltage

Check voltage at the relay coil with a D.C. voltmeter during the microwave cooking operation.

DC. voltage indicated - Defective relay.

DC. voltage not indicated - Check diode which is connected to the relay coil. If diode is good, control unit is defective.

RELAY SYMBOL	OPERATIONAL VOLTAGE	CONNECTED COMPONENTS
RY1	Approx. 18V D.C.	Oven lamp / Stirrer motor
RY2	Approx. 18V D.C.	Power transformer
RY3	Approx. 18V D.C.	Oven common relay
RY4	Approx. 18V D.C.	Top heater
RY5	Approx. 24V D.C.	Fan motor (Microwave)
RY6	Approx. 24V D.C.	Fan motor (Oven)
RY7	Approx. 24V D.C.	Oven lamp (Oven)
RY8	Approx. 24V D.C.	Door lock motor (Oven)
RY9	Approx. 24V D.C.	Convection motor
RY10	Approx. 24V D.C.	Warmer (Cook top)
RY11	Approx. 24V D.C.	Switching power supply
RY-B	Approx. 24V D.C.	Bottom heater
RY-C	Approx. 24V D.C.	Convection heater

**TEST PROCEDURES**

PROCEDURE LETTER	COMPONENT TEST
------------------	----------------

8. Reconnect all leads removed from components during testing.
9. Re-install the covers.
10. Reconnect the power supply cord after the cabinets are installed.
11. Run the drawer and check all function.

**D DEFROST TEST**

**WARNING :** The unit should be fully assembled before following procedure.

- (1) Place one cup of water in the center of the turntable tray in the oven cavity.
- (2) Close the door, touch the Stop/Clear (M) pad and touch the Defrost pad on the LCD. Then touch the Steaks/Chops pad on the LCD. And touch the number pad 5 on the LCD. (Now, weight 0.5lb is set.) And then touch the start pad on the LCD.
- (3) The oven is in Defrost cooking condition.
- (4) The oven will operate as follows

WEIGHT	1ST STAGE		2ND STAGE		3RD. STAGE	
	LEVEL	TIME	LEVEL	TIME	LEVEL	TIME
0.5lb	60%	20sec.	40%	20sec.	30%	45sec.

- (5) If improper operation is indicated, the control unit is probably defective and should be checked.

**E PROCEDURES TO BE TAKEN WHEN THE FUSE ON THE PRINTED WIRING BOARD (PWB) IS OPEN.**

To protect the electronic circuits, this model is provided with a fuse added to the primary on the PWB.

1. Fuse check and repairs.
  - 1) Disconnect the power supply cord, and then disassemble as per "OVEN/MICROWAVE DRAWER DISASSEMBLY" page 40.
  - 2) Open the drawer and block it open.
  - 3) Discharge high voltage capacitor.
  - 4) If the Fuse is blown, replace power unit.
  - 5) Make a visual inspection of the varistor. Check for burned damage. If the varistor has been burned, replace the power unit.
  - 6) Examine the touch control transformer with a tester for the presence of layer short-circuit (check the primary coil resistance which is approximately  $60\Omega \pm 10\%$ ). If any abnormal condition is detected, replace the touch control transformer.
  - 7) Reconnect all leads removed from components during testing.
  - 8) Re-install the covers.
  - 9) Reconnect the power supply cord after the outer case is installed.
  - 10) Run the oven and check all functions.
  
2. Follow the troubleshooting guide given below, if indicator does not light up after above check and repairs are finished.
  - 1) Disconnect the power supply cord, and then disassemble as per "OVEN/MICROWAVE DRAWER DISASSEMBLY" page 40.
  - 2) Open the door and block it open.
  - 3) Discharge high voltage capacitor.
  - 4) Disconnect the leads to the primary of the power transformer.
  - 5) Ensure that these leads remain isolated from other components and oven chassis by using insulation tape.
  - 6) After that procedure, re-connect the power supply cord.
  - 7) Follow the troubleshooting guide given below for repair.

**TEST PROCEDURES****PROCEDURE  
LETTER****COMPONENT TEST**

STEPS	OCCURRENCE	CAUSE OR CORRECTION
1	The rated AC voltage is not present between Pin Nos. 1 and 3 of the 2-pin connector (CN-B).	Check supply voltage and oven power cord.
2	The rated AC voltage is present at primary side of touch control transformer.	Touch control transformer or secondary circuit defective. Check and replace touch control transformer or power unit .

- 8) Reconnect all leads removed from components during testing.
- 9) Re-install the covers.
- 10) Reconnect the power supply cord after the cabinets are installed.
- 11) Run the oven and check all functions.

**F****AH SENSOR TEST****Checking the initial sensor cooking condition****WARNING :** The oven should be fully assembled before following procedure.

- (1) The oven should be plugged in at least two minutes before sensor cooking.
- (2) Room temperature should not exceed 95°F (35°C).
- (3) The unit should not be installed in any area where heat and steam are generated. The unit should not be installed, for example, next to a conventional surface unit. Refer to the "INSTALLATION INSTRUCTIONS" of the operation manual.
- (4) Exhaust vents are provided on the back of the unit for proper cooling and air flow in the cavity. To permit adequate ventilation, be sure to install so as not to block these vents. There should be some space for air circulation.
- (5) Be sure the exterior of the cooking container and the interior of the oven are dry. Wipe off any moisture with a dry cloth or paper towel.
- (6) The Sensor works with food at normal storage temperature. For example, chicken pieces would be at refrigerator temperature and canned soup at room temperature.
- (7) Avoid using aerosol sprays or cleaning solvents near the oven while using Sensor settings. The sensor will detect the vapor given off by the spray and turn off before food is properly cooked.
- (8) If the sensor has not detected the vapor of the food, ERROR will appear and the oven will shut off.

Water load cooking test

**WARNING :** The oven should be fully assembled before following procedure.

Make sure the oven has been plugged in at least two minutes before checking sensor cook operation. The cabinet should be installed and screws tightened.

- (1) Fill approximately 200 milliliters (7.2 oz) of tap water in a 1000 milliliter measuring cup.
- (2) Place the container on the center of tray in the oven cavity.
- (3) Close the door.
- (4) Touch the UPPER MICROWAVE OVEN pad, ^ pad, v pad, START MINUTE PLUS pad and the SENSOR LOAD pad on the LCD. And touch the number pad 4 once. Now, the oven is in the sensor cooking condition, and "20BIT" and "MICRO" will appear in the display.
- (5) The oven will operate for the first 16 seconds, without generating microwave energy.

**NOTE:** ERROR will appear if the door is opened or STOP/CLEAR pad is touched during first stage of sensor cooking.

- (6) After approximately 16 seconds, microwave energy is produced.

If ERROR is displayed or the oven does not turn off, replace the AH sensor or check the control unit, refer to explanation below.

**TESTING METHOD FOR AH SENSOR AND/OR CONTROL UNIT**

To determine if the sensor is defective, the simplest method is to replace it with a new replacement sensor.

- 1) Disconnect the power supply cord, and then disassemble as per "OVEN/MICROWAVE DRAWER DISASSEMBLY" page 40.
- 2) Open the drawer and block it open.
- 3) Discharge high voltage capacitor.
- 4) Remove the AH sensor.

## TEST PROCEDURES

**PROCEDURE  
LETTER**

**COMPONENT TEST**

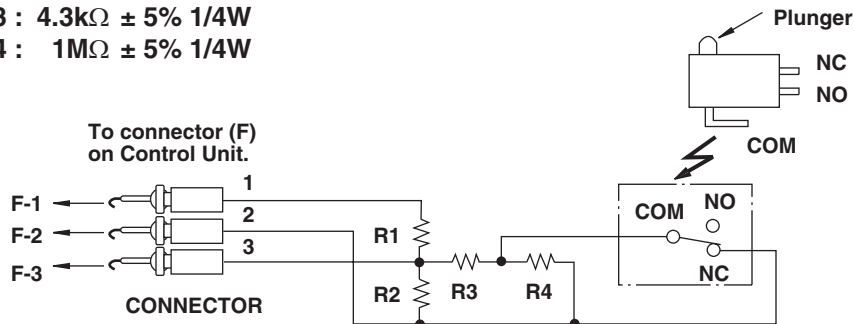
- (5) Install the new AH sensor.
  - (6) Reconnect all leads removed from components during testing.
  - (7) Re-install the outer case (cabinet).
  - (8) Reconnect the power supply cord after the cabinets are installed.
  - (9) Reconnect the oven to the power supply and check the sensor cook operation as follows:
    - 9-1. Fill approximately 200 milliliters (7.2 oz) of tap water in a 1000 milliliter measuring cup.
    - 9-2. Place the container on the center of tray in the oven cavity.
    - 9-3. Close the door.
    - 9-4. Touch the UPER MICROWAVE OVEN pad,  $\wedge$  pad,  $\vee$  pad, START MINUTE PLUS pad and the SENSOR LOAD pad on the LCD. And touch the number pad 4 once.
    - 9-5. The control panel is in automatic Sensor operation.
    - 9-6. The oven turns off automatically, and the time for detecting moisture will be displayed.
- If new sensor dose not operate properly, the problem is with the control unit, and refer to explanation below.

### CHECKING CONTROL UNIT

- (1) Disconnect the power supply cord, and then disassemble as per "OVEN/MICROWAVE DRAWER DISASSEMBLY" page 40.
- (2) Open the drawer and block it open.
- (3) Discharge high voltage capacitor.
- (4) Disconnect the sensor connector that is mounted to control panel.
- (5) Then connect the dummy resistor circuit (see fig.) to the sensor connector of control panel.
- (6) Disconnect the leads to the primary of the power transformer.
- (7) Ensure that these leads remain isolated from other components and oven chassis by using insulation tape.
- (8) After that procedure, re-connect the power supply cord.
- (9) Check the sensor cook operation proceed as follows:
  - 9-1. Close the door.
  - 9-2. Touch the UPER MICROWAVE OVEN pad,  $\wedge$  pad,  $\vee$  pad, START MINUTE PLUS pad and the SENSOR LOAD pad on the LCD. And touch the number pad 4 once.
  - 9-3. The control panel is in the sensor cooking operation.
  - 9-4. After approximately 25 seconds, push plunger of select switch for more than 3 seconds. This condition is same as judgement by AH sensor.
  - 9-5. After approximately 3 seconds, the display shows " X X . X X " which is the time for detecting moisture.

If the above is not the case, the control unit is probably defective.  
If the above is proper, the AH sensor is probably defective.
- (10) Disconnect the power supply cord, and the covers.
- (11) Open the door and block it open.
- (12) Discharge high voltage capacitor.
- (13) Disconnect the dummy resistor circuit from the sensor connector of control panel.
- (14) Carry out necessary repair.
- (15) Reconnect all leads removed from components during testing and repairing.
- (16) Re-install the covers.
- (17) Reconnect the power supply cord after the cabinets are installed. Run the oven and check all functions.
- (18) Carry out "Water load cooking test" again and ensure that the oven works properly.

**R1, R2 : 22Ω ± 1% 1/2W**  
**R3 : 4.3kΩ ± 5% 1/4W**  
**R4 : 1MΩ ± 5% 1/4W**



## TEST PROCEDURES

PROCEDURE  
LETTER

COMPONENT TEST

## G SURFACE ELEMENT CONTROL SYSTEMS

Two types of surface elements control systems are covered in this manual.

1. Standard infinite switch.
2. Dual infinite switch.

**Standard infinite switch:**

The surface elements and standard infinite switches provide an infinite choice of heat settings for cooking. Controls are safety type and must be pushed in before turning. All surface controls are marked on the control panel for their respective heating element. Power is supplied to the surface elements through the infinite switch contacts P2-4 and P1-2. During actual surface element operation, if the control is set to the high position contacts P1-2 are lock closed providing continuous power to the element. In all other setting contacts L2-H2 will cycle to maintain the correct heat setting. Contacts L1-P provide power to the surface element indicator light.

**Troubleshooting:**

There are four ways a surface control system with a standard infinite switch can fail.

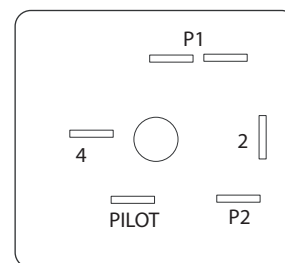
1. The element does not heat.
2. The switch does not cycle the element off and on when set to a position other than high.
3. The element operates correctly, but the indicator light does not glow.
4. Indicator light glows with all infinite switches in the off position.

**NOTE:** If the indicator light glows very dimly with all the switches in the off position. This problem is caused by a capacitive feed over in the wiring and can be corrected by connecting a 100,000 Ohm 1/4 watt resistor in parallel with the light.

Continuity tests can be performed on the infinite switch contacts. All tests should be performed with power to the range disconnected, and wiring removed from the switch. Set an ohmmeter on R X 1K scale and check the contacts in the following chart and switch terminal diagram.

Contacts	Dial Position		
	OFF	LO-MED	HI
P2 - P	O	X	X
P2 - 4	O	X	X
P1 - 2	O	X - C	X

O - open      X - closed

**Element does not heat:**

Checking the system with a Voltmeter, if the element does not heat up.

1. Remove the back of the control panel to expose the switch terminals.
2. With a Voltmeter set for AC on a scale higher than 240 Volts measure the voltage drop between terminals P2 and P1. If the meter reads zero the wiring between the main terminal block on the range and the switch is open. If the meter reads line to line voltage (around 240 VAC) go to step 3.
3. With the switch turned to the high position measure the voltage drop between terminals 4 and 2. If the meter reads zero the switch is defective. If the meter reads line to line voltage the switch is good. If the range has standard elements go to step 4. If the range has a glass smooth go to step 5.
4. Remove the element and measure the voltage drop between terminals of the terminal block. If the meter reads zero the terminal block or the wiring between the switch and the terminal block is open. If the meter reads line to line voltage the element is defective.
5. Raise the top and locate the two terminals on the element that the wires from 4 and 2 are on. Measure the voltage drop between the two terminals. If the meter reads zero the wires

**NOTE:** Always inspect the terminal block for burnt spots that can cause poor connection.

## TEST PROCEDURES

PROCEDURE  
LETTER

## COMPONENT TEST

between the switch and the element are open. If the meter reads line to line voltage the element is defective.

**Element does not cycle:**

If the element does not cycle when the switch is set in a position other than high the switch is defective.

**Indicator light does not glow:**

If indicator light does not glow when the switch is turned on, remove the back panel of the backguard, turn the switch on, and measure the voltage drop between terminals P and L2. If the meter reads zero the switch is defective. If the meter reads line to line voltage (around 240 VAC) the light or the wiring to the light is defective.

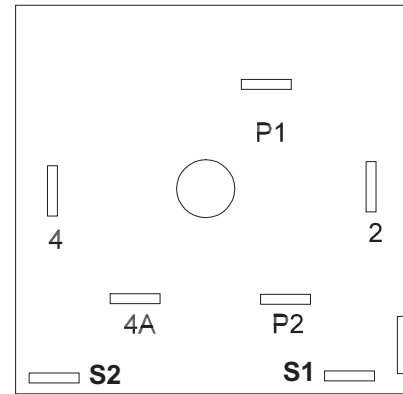
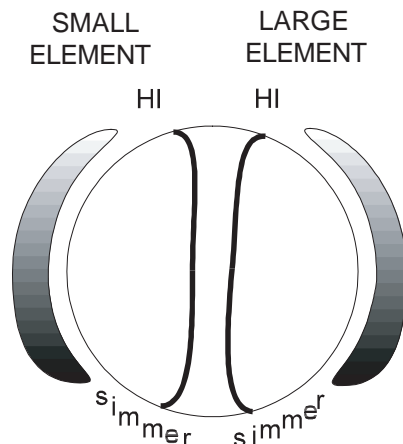
**Indicator light glows full brilliance with all top element switches off:**

If indicator light glows full brilliance with all top element switches off, one or more of the switches are defective. Disconnect electrical power from the range, and remove the back panel of the backguard. Disconnect the wire from the P terminal on all switches but one switch. Reconnect power. If the indicator light glows with the switch in the off position, the switch is defective. If the indicator light does not glow, the switch is good. Check each switch by disconnecting the wires from all the other P terminals but the switch you are testing.

**Dual infinite switch:**

The dual infinite switch is used to control the expandable and bridge elements on electric smooth top ranges. The dual infinite switches provide an infinite choice of heat settings for cooking, and two selection of element sizes. Controls are safety type and must be pushed in before turning. All surface controls are marked on the control panel for their respective heating element.

When the knob is turned clockwise, less than 180 degrees, contacts P2 to 4, P2 to 4A, and P1 to 2 closes



providing power to both elements. When the knob is turned counterclockwise, less than 180 degrees, contacts P2 to 4 and P1 to 2 close providing power to the inner element. During actual surface element operation, if the control is set to the high position contacts P1 to 2 are locked closed providing continuous power to the element. In all other settings contacts P1 to 2 will cycle to maintain the correct heat setting. Contact 4 to L2 provides power to the surface element indicator light.

See Cook Surface Schematic, Fig. 1

**Troubleshooting:**

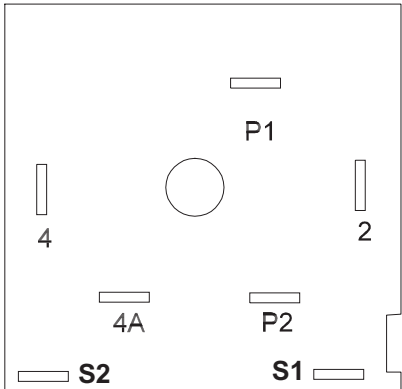
There are six ways a surface control system with a dual infinite switch can fail.

1. Both elements do not heat.
2. The outer element does not heat.
3. The inner element does not heat.
4. The switch does not cycle the element off and on when set to a position other than high.
5. The element operates correctly, but the indicator light does not glow.
6. Indicator light glows with all the infinite switches in the off position.

**NOTE:** If the indicator light glows very dimly with all the switches in the off position. This problem is caused by a capacitive feed over in the wiring and can be corrected by connecting a 100,000 Ohm 1/4 watt resistor in parallel with the light.



## TEST PROCEDURES

PROCEDURE LETTER	COMPONENT TEST
<p><b>Both elements do not heat:</b></p> <p>Checking the system with a Voltmeter, if the elements do not heat up:</p> <ol style="list-style-type: none"> <li>Remove the back panel of the backguard to expose the switch terminals.</li> <li>With a Voltmeter set for AC and a scale higher than 240 Volts measure the voltage drop between terminals P1 and P2. If the meter reads zero the wiring between the main terminal block on the range and the switch is open. If the meter reads line to line voltage (around 240 VAC) go to step 3.</li> <li>With the switch turned clockwise to the HI position, measure the voltage drop between terminals 4 and 2. If the meter reads zero the switch is defective. If the meter reads line to line voltage measure the voltage drop between terminals 4A and 2. If the meter reads line to line voltage the switch is good. Go to step 4.</li> <li>Raise the top and locate the two terminals on the element with the wires from terminals 4 and 2 are connected. Measure the voltage drop between these two terminals. If the meter reads zero the wires between the switch and the element are open. If the meter reads line to line voltage the element is defective.</li> </ol>	<ol style="list-style-type: none"> <li>With the switch turned clockwise to the high position measure the voltage drop between terminals 4 and 2. If the meter reads zero the switch is defective. If the meter reads line to line voltage, go to step 3.</li> <li>Raise the top and locate the two terminals on the element where the wires from terminals 4 and 2 are connected. Measure the voltage drop between these two terminals. If the meter reads zero the wires between the switch and the element are open. If the meter reads line to line voltage the element is defective.</li> </ol>
<p><b>Outer element doesn't heat, but inner element does:</b></p> <p>Checking the system with a Voltmeter, if the outer element does not heat, but the inner element does:</p> <ol style="list-style-type: none"> <li>Remove the back panel of the backguard to expose the switch terminals.</li> <li>With the switch turned clockwise to the high position measure the voltage drop between terminals 4A and 2. If the meter reads zero the switch is defective. If the meter reads line to line voltage, go to step 3.</li> <li>Raise the top and locate the two terminals on the element where the wires from terminals 4A and 2 are connected. Measure the voltage drop between these two terminals. If the meter reads zero the wires between the switch and the element are open. If the meter reads line to line voltage the element is defective.</li> </ol>	<p><b>Elements do not cycle:</b></p> <p>If the elements do not cycle when the switch is set in a position other than high the switch is defective.</p> <p><b>Indicator light does not glow:</b></p> <p>If indicator light does not glow when the switch is turned on, remove the back panel of the backguard, turn the switch on, and measure the voltage drop between terminals 4 and L2. If the meter reads zero the switch is defective. If the meter reads line to line voltage (around 240VAC) the light or the wiring to the light is defective.</p>
<p><b>Inner element doesn't heat, but outer element does:</b></p> <p>Checking the system with a Voltmeter, if the inner element does not heat, but the outer element does:</p> <ol style="list-style-type: none"> <li>Remove the back panel of the backguard to expose the switch terminals.</li> </ol>	<p><b>Indicator light glows full brilliance with all top element switches off:</b></p> <p>If indicator light glows full brilliance with all top element switches off, one or more of switches are defective. Disconnect electrical power from the range, and remove the back panel of the backguard. Disconnect the wire from terminal 4 on the switches from all but one switch. Reconnect power. If the indicator light glows with the switch in the off position the switch is defective. If the indicator light does not glow the switch is good. Check each dual infinite switch by disconnecting the wires from all the other 4 terminals but the switch you are testing.</p> 

See Cook Surface Schematic, Fig. 1

PROCEDURE  
LETTER

## COMPONENT TEST

---

Refer to the disassembly instructions found on Page 16.

---

H

**MAGNETRON ASSEMBLY TEST**

1. Disconnect the power supply cord.
2. Open the drawer and keep it open.
3. To discharge high voltage capacitor, wait for 60 seconds.
4. To test for an open filament, isolate the magnetron from the high voltage circuit. A continuity check across the magnetron filament leads should indicate less than 1 ohm.
5. To test for a shorted magnetron, connect the ohmmeter leads between the magnetron filament leads and chassis ground. This test should indicate an infinite resistance. If there is little or no resistance the magnetron is grounded and must be replaced.
6. Reconnect all leads removed from components during testing.
7. Reassemble the unit.
8. Reconnect the power supply cord.
9. Run the oven and check all functions.

**MICROWAVE OUTPUT POWER**

The following test procedure should be carried out with the microwave oven in a fully assembled condition.

HIGH VOLTAGES ARE PRESENT DURING THE COOK CYCLE, SO EXTREME CAUTION SHOULD BE OBSERVED.

Power output of the magnetron can be measured by performing a water temperature rise test. This test should only be used if above tests do not indicate a faulty magnetron and there is no defect in the following components or wiring: inverter unit. This test will require a 16 ounce (453cc) measuring cup and an accurate mercury thermometer or thermocouple type temperature tester. For accurate results, the following procedure must be followed carefully:

1. Fill the measuring cup with 16 oz. (453cc) of tap water and measure the temperature of the water with a thermometer or thermocouple temperature tester. Stir the thermometer or thermocouple through the water until the temperature stabilizes. Record the temperature of the water.
2. Place the cup of water in the oven. Operate oven at POWER 10(HIGH) selecting more than 60 seconds cook time. Allow the water to heat for 60 seconds, measuring with a stop watch, second hand of a watch or the digital read-out countdown.
3. Remove the cup from the oven and again measure the temperature, making sure to stir the thermometer or thermocouple through the water until the maximum temperature is recorded.
4. Subtract the cold water temperature from the hot water temperature. The normal result should be 28° to 54°F (16° to 30°C) rise in temperature. If the water temperatures are accurately measured and tested for the required time period the test results will indicate if the magnetron tube has low power output (low rise in water temperature) which would extend cooking time or high power output (high rise in water temperature) which would reduce cooking time. Because cooking time can be adjusted to compensate for power output, the magnetron tube assembly should be replaced only if the water temperature rise test indicates a power output well beyond the normal limits. The test is only accurate if the power supply line voltage is 120 volts and the oven cavity is clean.

I

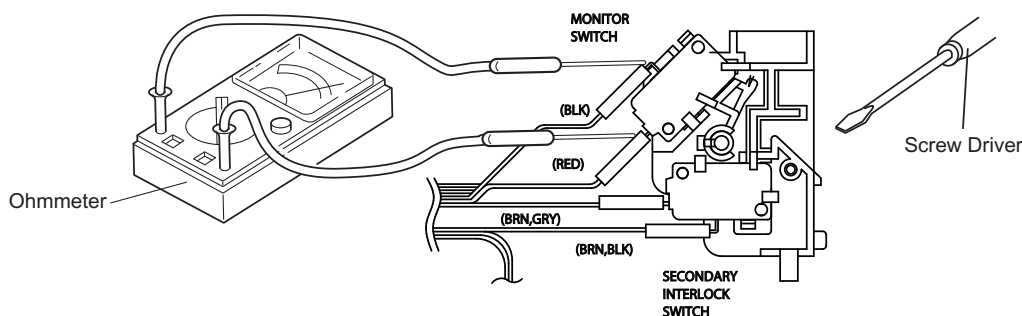
**OVEN THERMAL CUT-OUT TEST**

1. Disconnect the power supply cord.
2. Open the drawer and keep it open.
3. To discharge high voltage capacitor, wait for 60 seconds.
4. A continuity check across the thermal cut-out terminals should indicate a closed circuit unless the temperature of the thermal cut-out reaches approximately 293°F(145°C).  
An open thermal cut-out indicates overheating of the oven, exchange the oven thermal cut-out and check inside of oven cavity and for improper setting of cooking time or operation of control unit. Check for restricted air flow through the vent holes of the oven cavity, especially the cooling fan and air guide.
5. Reconnect all leads removed from components during testing.
6. Reassemble the unit.
7. Reconnect the power supply cord.
8. Run the unit and check all functions.

CAUTION: IF THE THERMAL CUT-OUT INDICATES AN OPEN CIRCUIT AT ROOM TEMPERATURE, REPLACE THERMAL CUT-OUT.

PROCEDURE LETTER	COMPONENT TEST
J	<b>SECONDARY INTERLOCK SWITCH TEST</b>
	<ol style="list-style-type: none"> <li>1. Disconnect the power supply cord.</li> <li>2. Open the drawer and keep it open.</li> <li>3. To discharge high voltage capacitor, wait for 60 seconds.</li> <li>4. Isolate the switch and connect the ohmmeter to the common (COM.) and normally open (NO) terminal of the switch. The meter should indicate an open circuit with the drawer open and a closed circuit with the drawer closed. If improper operation is indicated, replace the secondary interlock switch.</li> <li>5. Reconnect all leads removed from components during testing.</li> <li>6. Reassemble the unit.</li> <li>7. Reconnect the power supply cord.</li> <li>8. Run the oven and check all functions.</li> </ol>
K	<b>STOP SWITCH TEST</b>
	<p data-bbox="354 676 539 701"><b>STOP SWITCH</b></p> <ol style="list-style-type: none"> <li>1. Disconnect the power supply cord.</li> <li>2. Open the drawer and keep it open.</li> <li>3. To discharge high voltage capacitor, wait for 60 seconds.</li> <li>4. Isolate the switch and connect the ohmmeter to the common (COM.) and normally open (NO) terminal of the switch. The meter should indicate an open circuit with the drawer open and a closed circuit with the drawer closed. If improper operation is indicated, replace the stop switch.</li> <li>5. Reconnect all leads removed from components during testing.</li> <li>6. Reassemble the unit.</li> <li>7. Reconnect the power supply cord.</li> <li>8. Run the oven and check all functions.</li> </ol> <p data-bbox="354 1039 1533 1096">NOTE: If the stop switch contacts fail in the open position and the door is closed, the cooling fan motor, stirrer motor and oven light will be activated by RY1.</p>

L	<b>MONITOR SWITCH TEST</b>
	<ol style="list-style-type: none"> <li>1. Disconnect the power supply cord.</li> <li>2. Open the drawer and keep it open.</li> <li>3. To discharge high voltage capacitor, wait for 60 seconds.</li> <li>4. Before performing this test, make sure that the secondary interlock switch, according to the above Switch Test Procedure. Disconnect the wire lead from the monitor switch (COM) terminal. Check the monitor switch operation by using the ohmmeter as follows. When the drawer is open, the meter should indicate a closed circuit. When the monitor switch actuator is pushed by a screw driver through the lower latch hole on the front plate of the oven cavity with the drawer opened (in this condition the plunger of the monitor switch is pushed in), the meter should indicate an open circuit. If improper operation is indicated, the switch may be defective and both the monitor switch, plus fuse will need to be replaced. After testing the monitor switch, reconnect the wire lead to the monitor switch (COM) terminal and check the continuity of the monitor circuit.</li> <li>5. Reconnect all leads removed from components during testing.</li> <li>6. Reassemble the unit.</li> <li>7. Reconnect the power supply cord.</li> <li>8. Run the oven and check all functions.</li> </ol>



## TEST PROCEDURES

PROCEDURE LETTER	COMPONENT TEST
<b>M</b>	<p><b><u>BLOWN MONITOR FUSE TEST</u></b></p> <ol style="list-style-type: none"> <li>1. Disconnect the power supply cord.</li> <li>2. Open the drawer and block it open.</li> <li>3. To discharge high voltage capacitor, wait for 60 seconds.</li> <li>4. If the monitor fuse is blown when the drawer is opened, check the primary interlock switch, secondary interlock switch and monitor switch according to the "TEST PROCEDURE" for those switches before replacing the blown monitor fuse.</li> </ol> <p style="text-align: center;"><b>CAUTION: BEFORE REPLACING A BLOWN MONITOR FUSE, TEST THE SECONDARY INTERLOCK SWITCH, STOP SWITCH AND MONITOR SWITCH FOR PROPER OPERATION.</b></p> <p style="padding-left: 40px;">If the monitor fuse is blown by improper switch operation, the monitor fuse and monitor switch must be replaced with "monitor fuse and monitor switch assembly" part number FFS-BA018/KIT, even if the monitor switch operates normally. The monitor fuse and monitor switch assembly is comprised of a 20 ampere fuse and switch.</p> <ol style="list-style-type: none"> <li>5. Reconnect all leads removed from components during testing.</li> <li>6. Reassemble the unit.</li> <li>7. Reconnect the power supply cord.</li> <li>8. Run the oven and check all functions.</li> </ol>

<b>N</b>	<p><b><u>POWER TRANSFORMER TEST</u></b></p> <ol style="list-style-type: none"> <li>1. Disconnect the power supply cord.</li> <li>2. Open the drawer and block it open.</li> <li>3. Discharge high voltage capacitor.</li> <li>4. Disconnect the primary input terminals and measure the resistance of the transformer with an ohmmeter. Check for continuity of the coils with an ohmmeter. On the R x 1 scale, the resistance of the primary coil should be less than 1 ohm and the resistance of the high voltage coil should be approximately 90 ohms; the resistance of the filament coil should be less than 1 ohm.</li> <li>5. Reconnect all leads removed from components during testing.</li> <li>6. Reassemble the unit.</li> <li>7. Reconnect the power supply cord.</li> <li>8. Run the oven and check all functions.</li> </ol> <p style="padding-left: 40px;">(HIGH VOLTAGES ARE PRESENT AT THE HIGH VOLTAGE TERMINAL, SO DO NOT ATTEMPT TO MEASURE THE FILAMENT AND HIGH VOLTAGE.)</p>
----------	--

<b>O</b>	<p><b><u>FAILURE CODES</u></b></p> <p>The following failure codes will be displayed on the Control Panel.</p> <p><b>EE 6 (displayed when oven starts) -</b> Oven Thermistor is open.</p> <p style="padding-left: 40px;">Check thermistor or control unit.</p> <p><b>EE 7 (displayed when oven starts) -</b> Oven Thermistor is shorted.</p> <p style="padding-left: 40px;">Check thermistor or control unit.</p> <p><b>EE L (displayed after 1 minute of cooking or self cleaning) -</b> Lower door lock error.</p> <p style="padding-left: 40px;">Check lock motor, lock switch (RY 8) or control unit.</p>
----------	--

**SPECAIL FAILURE NOTE:**

During the Microwave Drawer operation, if it goes dead, check each Thermal Cut-out first. This is due to the whole control unit being powered by Line L1 (refer to Schematic on page 13).

## OUTLINE OF TOUCH CONTROL PANEL

The touch control section consists of the following units.

- (1) Keyboard unit
- (2) Control Unit
- (3) Power unit

The principal functions of these units and the signals communicated among them are explained below.

**Keyboard unit**

The keyboard unit is composed of a matrix, signals generated in the LSI are sent to the keyboard unit. When a key pad is touched, a signal is completed through the keyboard unit and passed back to the LSI to perform the function that was requested.

**Control Unit and Power Unit**

Control unit consists of LSI, IC, reset circuit, indicator circuit, power source circuit, relay circuit, buzzer circuit, synchronizing signal circuit, keyboard unit circuit, humidity sensor circuit and back light circuit.

**1) IC1 (LSI)**

This is a microcomputer, responsible for controlling the entire control unit.

**2) IC2**

This is the IC to judge the selected key.

**3) IC3**

This is the IC to judge the selected key.

**4) IC4**

This is the IC to judge the selected key.

**5) IC5**

This is the IC to amplify the signal from the humidity sensor and the IC to amplify the signal to adjust the contrast of LCD.

**6) IC6**

This is memory IC.

**7) IC7**

This is the IC to drive the relays.

**8) IC8**

This is the IC to drive the relays.

**9) Reset Circuit**

This circuit generates a signal which resets the LSI (IC1) to the initial state when power is supplied.

**10) Indicator Circuit**

A circuit to drive the Liquid Crystal Displays (LCD1).

**11) Power Source Circuit**

This circuit generates voltages necessary in the control unit from the AC line voltage.

In addition, the synchronizing signal is available in order to compose a basic standard time in the clock circuit.

Symbol	Voltage	Application
VC	+5V	LSI(IC1)

**12) Relay Circuit**

A circuit to drive the magnetron, fan motor, stirrer motor, convection motor, door lock motor, bottom heater, top heater, convection heater and light the oven lamp.

**13) Buzzer Circuit**

The buzzer is responsive to signals from the LSI to emit audible sounds (key touch sound and completion sound).

**14) Synchronizing Signal Circuit**

The power source synchronizing signal is available in order to compose a basic standard time in the clock circuit.

It accompanies a very small error because it works on commercial frequency.

**15) Door Sensing Switch (Microwave drawer)**

A switch to "tell" the LSI if the drawer is open or closed.

**16) Door Switch (Oven)**

A switch to "tell" the LSI if the oven door is open or closed.

**17) Door Lock Monitor Switch (Oven)**

A switch to "tell" the LSI if the oven door is locked or not.

**18) Door Position Switch Front / Rear**

The switch to "tell" the position of the Microwave drawer door.

**19) Back Light Circuit**

A circuit to drive the back light (Light emitting diodes LD1- LD5).

**20) Cook Top Warmer Indicator Circuit**

A circuit to drive the indicator (LD10) for Cook Top Warmer.

**21) Transparent electrode (Touch key) on the LCD**

When the ① - ⑥ of the transparent electrodes are touched, the signal are input into the P96, P-95, P94, P92, P91 and P90 of the LSI (IC-1) to perform the function that was requested.

**22) Humidity Sensor Circuit**

This circuit detects moisture of the cooking food to allow its automatic cooking.

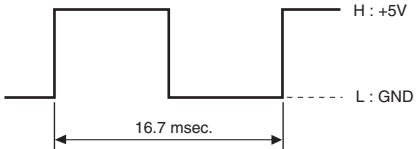
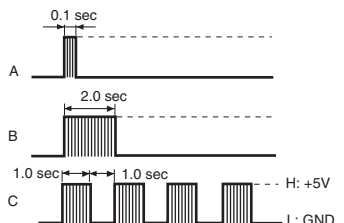
**23) Temperature Measurement Circuit : (OVEN THERMISTOR)**

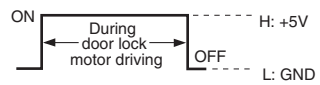







The temperature in the oven cavity is sensed by the thermistor. The variation of resistance according to sensed temperature is detected by the temperature measurement circuit and the result applied to LSI. The LSI uses this information to control the relay and display units.

## DESCRIPTION OF LSI (IC-1)


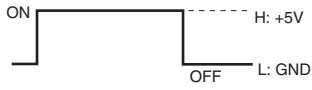


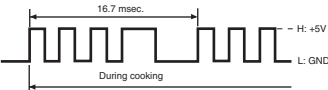
The I/O signal of the LSIs detailed in the following table.

Pin No.	Signal	I/O	Description
1	P96	IN	<b>Signal coming from Transparent electrode (touch key on the LCD).</b> When the ① key of the transparent electrode is touched, a corresponding signal out of OUT1 of IC-2 will be input into P96 of IC-1.
2	P95	IN	<b>Signal coming from Transparent electrode (touch key on the LCD).</b> When the ② key of the transparent electrode is touched, a corresponding signal out of OUT3 of IC-2 will be input into P95 of IC-1.
3	P94	IN	<b>Signal coming from Transparent electrode (touch key on the LCD).</b> When the ③ key of the transparent electrode is touched, a corresponding signal out of OUT4 of IC-2 will be input into P94 of IC-1.
4	P93	OUT	The signal to adjust the contrast of LCD is output to IC-5.
5	P92	IN	<b>Signal coming from Transparent electrode (touch key on the LCD).</b> When the ④ key of the transparent electrode is touched, a corresponding signal out of OUT1 of IC-3 will be input into P92.
6	P91	IN	<b>Signal coming from Transparent electrode (touch key on the LCD).</b> When the ⑤ key of the transparent electrode is touched, a corresponding signal out of OUT3 of IC-3 will be input into P91.
7	P90	IN	<b>Signal coming from Transparent electrode (touch key on the LCD).</b> When the ⑥ key of the transparent electrode is touched, a corresponding signal out of OUT4 of IC-3 will be input into P90.
8	BYTE	IN	Connected to VCC1.
9	CNVSS	IN	<b>Power source voltage: 0V (GND).</b> The power source voltage to drive the LSI (IC-1) is input. Connected to GND.
10	P87	OUT	Memory (EEPROM) clock out.
11	P86	IN/OUT	Memory (EEPROM) data input/output.
12	RESET	IN	<b>Auto clear terminal.</b> Signal is input to reset the LSI to the initial state when power is applied. Temporarily set to "L" level the moment power is applied, at this time the LSI is reset. Thereafter set at "H" level.
13	XOUT	OUT	<b>Internal clock oscillation frequency control output.</b> Output to control oscillation input of Xin.
14	VSS	IN	<b>Power source voltage: 0V (GND).</b> The power source voltage to drive the LSI (IC-1) is input. Connected to GND.
15	XIN	IN	<b>Internal clock oscillation frequency setting input.</b> The internal clock frequency is set by inserting the ceramic filter oscillation circuit with respect to Xout terminal.
16	VCC1	IN	<b>Power source voltage: +5.0V.</b> The power source voltage to drive the LSI (IC-1) is input to VCC1 terminal.
17	NMI	IN	Connected to VCC1.
18	P84	IN	<b>Input signal which communicates the drawer door close information to LSI from the door sensing switch.</b> Door opened; "L" level signal(0V). Door closed; "H" level signal(+5V).
19	P83	IN	<b>Input signal which communicates the drawer door open information to LSI from the door position switch front.</b> Door opened; "L" level signal(0V). Door closed; "H" level signal(+5V).

Pin No.	Signal	I/O	Description																																																																
20	INT0	IN	<p><b>Signal to synchronize LSI with commercial power source frequency.</b> This is the basic timing for all real time processing of LSI.</p> 																																																																
21	P81	OUT	<b>Signal to change the rotational direction is output to the Microwave drawer door open-close motor.</b>																																																																
22	TA4OUT	OUT	<p><b>Signal to sound buzzer.</b> A: Key touch sound. B: Completion sound. C: When the oven stops so that the food can be checked in Automatic cooking mode.</p> 																																																																
23	P77	OUT	<p><b>Magnetron high-voltage circuit driving signal.</b> To turn on and off the cook relay(RY2). In 100% power operation, the signals holds "H" level during microwave cooking and "L" level while not cooking. In other cooking modes (90%, 80%, 70%, 60%, 50%, 40%, 30%, 20%, 10%, 0%) the signal turns to "H" level and "L" level in repetition according to the power level.</p> <table border="1" data-bbox="1112 787 1502 1092"> <thead> <tr> <th rowspan="2">VARI.MODE</th> <th colspan="2">Microwave cooking mode</th> <th colspan="2">Other cooking mode</th> </tr> <tr> <th>ON TIME</th> <th>OFF TIME</th> <th>ON TIME</th> <th>OFF TIME</th> </tr> </thead> <tbody> <tr> <td>100% power</td> <td>32 sec.</td> <td>0 sec.</td> <td>60sec.</td> <td>0sec.</td> </tr> <tr> <td>90% power</td> <td>30 sec.</td> <td>2 sec.</td> <td>54sec.</td> <td>6sec.</td> </tr> <tr> <td>80% power</td> <td>26 sec.</td> <td>6 sec.</td> <td>48sec.</td> <td>12sec.</td> </tr> <tr> <td>70% power</td> <td>24 sec.</td> <td>8 sec.</td> <td>42sec.</td> <td>18sec.</td> </tr> <tr> <td>60% power</td> <td>22 sec.</td> <td>10 sec.</td> <td>36sec.</td> <td>24sec.</td> </tr> <tr> <td>50% power</td> <td>18 sec.</td> <td>14 sec.</td> <td>30sec.</td> <td>30sec.</td> </tr> <tr> <td>40% power</td> <td>16 sec.</td> <td>16 sec.</td> <td>24sec.</td> <td>36sec.</td> </tr> <tr> <td>30% power</td> <td>12 sec.</td> <td>20 sec.</td> <td>18sec.</td> <td>42sec.</td> </tr> <tr> <td>20% power</td> <td>8 sec.</td> <td>24 sec.</td> <td>12sec.</td> <td>48sec.</td> </tr> <tr> <td>10% power</td> <td>6 sec.</td> <td>26 sec.</td> <td>4sec.</td> <td>56sec.</td> </tr> <tr> <td>0% power</td> <td>0 sec.</td> <td>32 sec.</td> <td>0sec.</td> <td>60sec.</td> </tr> </tbody> </table>	VARI.MODE	Microwave cooking mode		Other cooking mode		ON TIME	OFF TIME	ON TIME	OFF TIME	100% power	32 sec.	0 sec.	60sec.	0sec.	90% power	30 sec.	2 sec.	54sec.	6sec.	80% power	26 sec.	6 sec.	48sec.	12sec.	70% power	24 sec.	8 sec.	42sec.	18sec.	60% power	22 sec.	10 sec.	36sec.	24sec.	50% power	18 sec.	14 sec.	30sec.	30sec.	40% power	16 sec.	16 sec.	24sec.	36sec.	30% power	12 sec.	20 sec.	18sec.	42sec.	20% power	8 sec.	24 sec.	12sec.	48sec.	10% power	6 sec.	26 sec.	4sec.	56sec.	0% power	0 sec.	32 sec.	0sec.	60sec.
VARI.MODE	Microwave cooking mode		Other cooking mode																																																																
	ON TIME	OFF TIME	ON TIME	OFF TIME																																																															
100% power	32 sec.	0 sec.	60sec.	0sec.																																																															
90% power	30 sec.	2 sec.	54sec.	6sec.																																																															
80% power	26 sec.	6 sec.	48sec.	12sec.																																																															
70% power	24 sec.	8 sec.	42sec.	18sec.																																																															
60% power	22 sec.	10 sec.	36sec.	24sec.																																																															
50% power	18 sec.	14 sec.	30sec.	30sec.																																																															
40% power	16 sec.	16 sec.	24sec.	36sec.																																																															
30% power	12 sec.	20 sec.	18sec.	42sec.																																																															
20% power	8 sec.	24 sec.	12sec.	48sec.																																																															
10% power	6 sec.	26 sec.	4sec.	56sec.																																																															
0% power	0 sec.	32 sec.	0sec.	60sec.																																																															
24	TA3OUT	OUT	Signal to change the rotational speed is output to the Microwave drawer door open-close motor.																																																																
25	TA2IN	IN	Plus signal coming from the Microwave drawer door open-close motor is input into TA2IN as revolution number.																																																																
26-30	P74-P70	OUT	Used for initial balancing of the bridge circuit (absolute humidity sensor).																																																																
31-33	A67-A65	OUT	Turminal not used.																																																																
34	P64	IN	<b>To input signal which communicates the oven door open/close information to LSI.</b> Door open "H" level signal (+5V). Door close "L" level signal (GND).																																																																
35	TXD0	IN	Signal coming from key unit.																																																																
36	RXD0	IN	Signal coming from key unit.																																																																
37	P61	OUT	<b>Signal to reset LSI.</b> Signal is output to reset IC-2, IC-3 and IC-4.																																																																
38	P60	IN	Signal coming from key unit.																																																																
39	RDY	IN	Connected to VCC2 (+3.3V).																																																																
40	ALE	OUT	Turminal not used.																																																																
41	HOLD	IN	Connected to VCC2 (+3.3V).																																																																
42	HLDA	OUT	Turminal not used.																																																																
43	BCLK	IN	Connected to VCC2 (+3.3V).																																																																
44	RD	OUT	Read strobe signal is outout to the LCD.																																																																
45	WRH	OUT	Turminal not used.																																																																
46	WR	OUT	Write strobe signal is outout to the LCD.																																																																

Pin No.	Signal	I/O	Description
47	P47	OUT	Reset signal is outout to the LCD.
48	CS2	OUT	Chip select signal is outout to the LCD.
49	P45	OUT	Turminal not used.
50	P44	OUT	Turminal not used.
51	P43	OUT	Signal to turn on the indicator for the Cook Top Warmer is output to the LED (LD10).
52	P42	OUT	<p><b>Door lock motor driving signal.</b> To turn on and off shut-off relay(RY8). “H”level during door lock motor driving “L” level otherwise</p> 
53	P41	OUT	Power source to drive the Microwave drawer door open-close motor is output.
54	P40	IN	Turminal not used.
55	P37	OUT	<p><b>Convection heater relay driving signal.</b> To turn on and off relay(RYC). “H” level: During convection heater relay ON. “L” level: During convection heater relay OFF.</p> 
56	P36	OUT	<p><b>Bottom heater relay driving signal.</b> To turn on and off relay(RYB). “H” level: During bottom heater relay ON. “L” level: During bottom heater relay OFF.</p> 
57	P35	OUT	<p><b>Cook top warmer driving signal.</b> To turn on and off relay(RY10). “H” level: During cook top warmer ON. “L” level: During cook top warmer OFF.</p> 
58	P34	OUT	<p><b>Oven convection motor driving signal.</b> To turn on and off relay(RY9). “H” level: During convection motor ON. “L” level: During convection motor OFF.</p> 
59 - 61	A11 - A9	OUT	Turminal not used.
62	VCC2	IN	<p><b>Power source voltage: +3.3V.</b> The power source voltage to drive the LSI (IC-1) is input to VCC2 terminal.</p>
63	A8	OUT	Turminal not used.
64	VSS	IN	<p><b>Power source voltage: 0V (GND).</b> VS voltage of power source circuit input. Connected to GND</p>
65 - 70	A7 - A2	OUT	Turminal not used.
71	A1	OUT	Register select signal is input to the LCD.
72	A0	OUT	Turminal not used.
73	P17	OUT	<p><b>Signal to sound buzzer.</b> A: Key touch sound (short beep). B: Completion sound (melody or long beep).</p>
74	P16	OUT	<p><b>Door lock motor (Oven) driving signal.</b> To turn on and off relay(RY8). “H” level: During door lock motor ON. “L” level: During door lock motor OFF.</p> 
75	P15	OUT	<p><b>Oven lamp (Oven) driving signal.</b> To turn on and off relay(RY7). “H” level: During oven lamp ON. “L” level: During oven lamp OFF.</p> 
76	P14	OUT	<p><b>Fan motor (Oven) driving signal.</b> To turn on and off relay(RY6). “H” level: During fan motor ON.</p> 



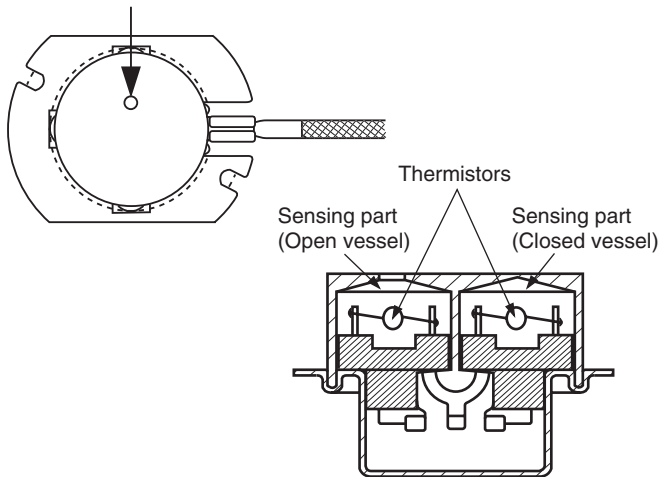
Pin No.	Signal	I/O	Description
77	P13	OUT	<p>“L” level: During fan motor OFF.</p> <p><b>Fan motor (Drawer) driving signal.</b> To turn on and off relay(RY5).</p> <p>“H” level: During fan motor ON.</p> <p>“L” level: During fan motor OFF.</p> 
78	P12	OUT	<p><b>Top heater driving signal.</b> To turn on and off relay(RY4).</p> <p>“H” level: During top heater ON.</p> <p>“L” level: During top heater OFF.</p> 
79	P11	OUT	<p><b>Oven common relay driving signal.</b> To turn on and off relay(RY3).</p> <p>“H” level: During oven common relay ON.</p> <p>“L” level: During oven common relay OFF.</p> 
80	P10	OUT	<p><b>Oven lamp and stirrer motor (drawer) driving signal.</b> To turn on and off relay(RY1).</p> <p>“H” level: During oven lamp and stirrer motor ON.</p> <p>“L” level: During oven lamp and stirrer motor OFF.</p> 
81 - 88	D7 - D0	OUT	Data signal is output to LCD driver.
89	AN7	OUT	Terminal not used.
90	AN6	IN	<b>AH sensor input.</b> This input is an analog input terminal from the AH sensor circuit, and connected to the A/D converter built into the LSI.
91	AN5	IN	Used for initial balancing of the bridge circuit (absolute humidity sensor). This input is an analog input terminal from the AH sensor circuit, and connected to the A/D converter built into the LSI.
92	AN4	IN	<b>Terminal to change the specifications of the LSI.</b> By using A/D converter contained in the LSI, DC voltage in accordance with the Model in operation is applied to set up its cooking constant.
93	AN3	IN	Input signal which inform the drawer door is in the middle position between the opened position and the closed position, to LSI from the door position switch rear.
94	AN2	IN	<b>Input signal which communicates the oven door locked information to LSI.</b> Door unlocked; “H” level signal(+5V). Door locked; “L” level signal(0V).
95	AN1	IN	<b>Input signal which communicates the oven door unlocked information to LSI.</b> Door locked; “H” level signal(+5V). Door unlocked; “L” level signal(0V).
96	AVSS	IN	<b>A/D converter power source voltage.</b> The power source voltage to drive the A/D converter in the LSI.
97	AN0	IN	<b>Temperature measurement input: OVEN THERMISTOR.</b> By inputting DC voltage corresponding to the temperature detected by the thermistor, this input is converted into temperature by the A/D converter built into the LSI.
98	VREF	IN	<b>Reference voltage input terminal.</b> A reference voltage applied to the A/D converter in the LSI. Connected to +5V.
99	AVCC	IN	<b>A/D converter power source voltage.</b> The power source voltage to drive the A/D converter in the LSI. Connected to Vcc1 (+5V).
100	P97	OUT	<p><b>Common relays driving signal. (Square Waveform : 60Hz)</b> To turn on and off the shut-off relays (RY1 and RY3). The square waveform voltage is delivered to the relays (RY1 and RY3) driving circuit.</p> 

## HUMIDITY SENSOR CIRCUIT

### (1) Structure of Humidity Sensor

The humidity sensor includes two thermistors as shown in the illustration. One thermistor is housed in the closed vessel filled with dry air while another in the open vessel. Each sensor is provided with the protective cover made of metal mesh to be protected from the external airflow.

ventilation opening for sensing

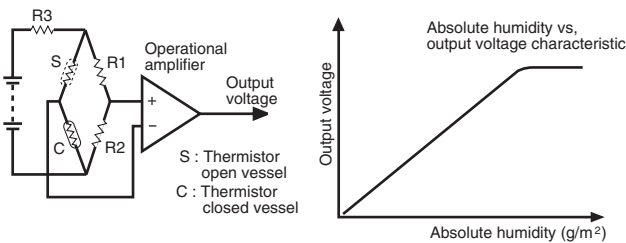


### (2) Operational Principle of Humidity Sensor

The figure below shows the basic structure of an absolute humidity sensor. A bridge circuit is formed by two thermistors and two resistors (R1 and R2). The output of the bridge circuit is to be amplified by the operational amplifier.

Each thermistor is supplied with a current to keep it heated at about 150°C (302°F), the resultant heat is dissipated in the air and if the two thermistors are placed in different humidity conditions they show different degrees of heat conductivity leading to a potential difference between them causing an output voltage from the bridge circuit, the intensity of which is increased as the absolute humidity of the air increases. Since the output is varied every minute, it is amplified by the operational amplifier.

Each thermistor is supplied with a current to keep it heated at about 150°C (302°F), the resultant heat is dissipated in the air and if the two thermistors are placed in different humidity conditions they show different degrees of heat conductivity leading to a potential difference between them causing an output voltage from the bridge circuit, the intensity of which is increased as the absolute humidity of the air increases. Since the output is varied every minute, it is amplified by the operational amplifier.



### (3) Detector Circuit of Humidity Sensor Circuit

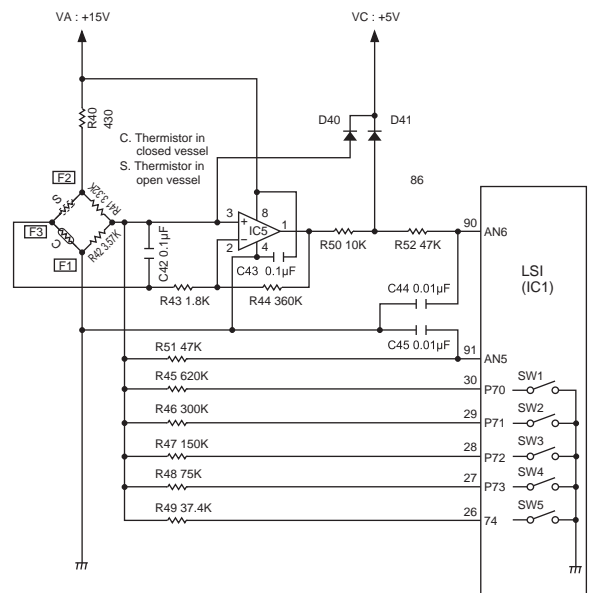
This detector circuit is used to detect the output voltage of the absolute humidity circuit to allow the LSI to control sensor cooking of the unit. When the unit is set in the sensor cooking mode, 16 seconds clearing cycle occurs than the detector circuit starts to function and the LSI observes the initial voltage available at its AN5 terminal.

With this voltage given, the switches SW1 to SW5 in the LSI are turned on in such a way as to change the resistance values in parallel with R45 ~ R49. Changing

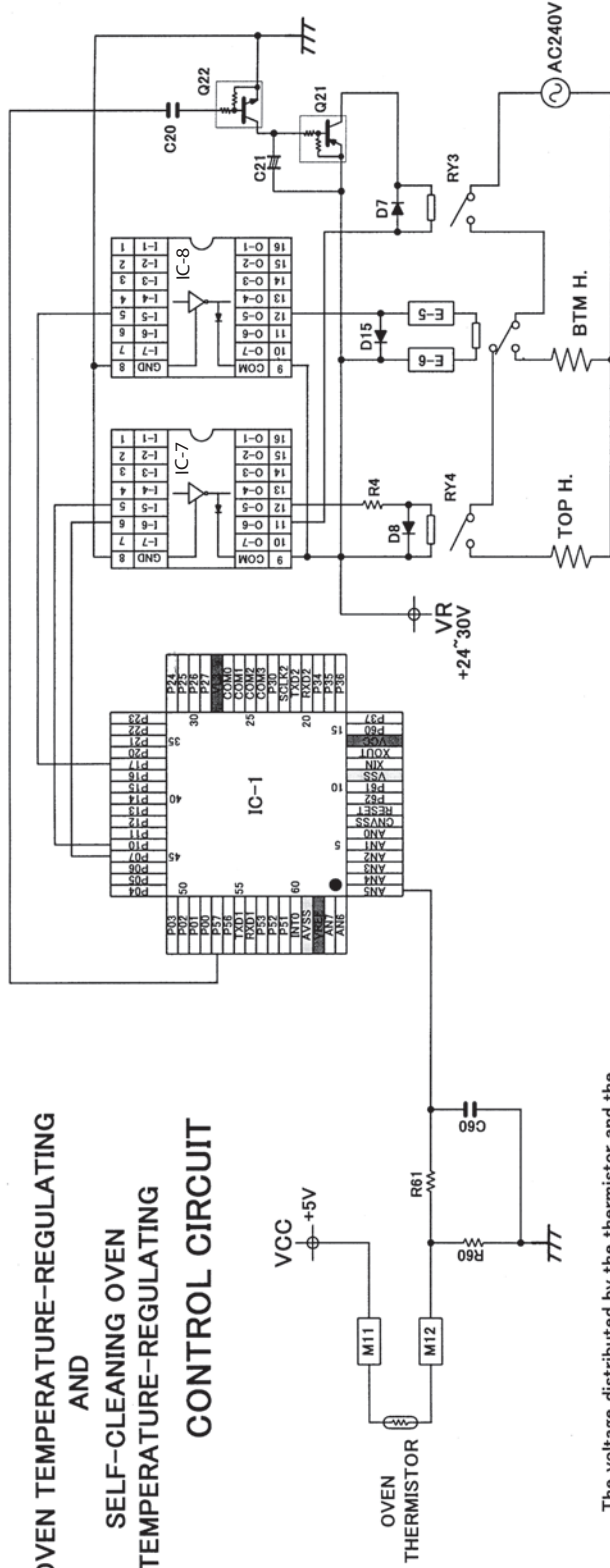
the resistance values results in that there is the same potential at both F-3 terminal of the absolute humidity sensor and AN5 terminal of the LSI. The voltage of AN6 terminal will indicate about +2.5V. This initial balancing is set up about 16 seconds after the unit is put in the Sensor Cooking mode. As the sensor cooking proceeds, the food is heated to generate moisture by which the resistance balance of the bridge circuit is deviated to increase the voltage available at AN5 terminal of the LSI.

Then the LSI observes that voltage at AN6 terminal and compares it with its initial value, and when the comparison rate reaches the preset value (fixed for each menu to be cooked), the LSI causes the unit to stop sensor cooking; thereafter, the unit goes in the next operation automatically.

When the LSI starts to detect the initial voltage at AN6 terminal 16 seconds after the unit has been put in the Sensor Cooking mode, if it is not possible to balance the bridge circuit due to disconnection of the absolute humidity sensor, ERROR will appear on the display and the cooking is stopped.



# OVEN TEMPERATURE/SELF CLEANING CONTROL CIRCUIT



## OVEN TEMPERATURE-REGULATING AND SELF-CLEANING OVEN TEMPERATURE-REGULATING CONTROL CIRCUIT

The voltage distributed by the thermistor and the resistance(R60) is input to the terminal(AN5) of the LSI.

A change in the resistance value of the thermistor is changed to the change in the voltage.

An input voltage is changed into the digital signal by the LSI which has an A/D converter.

A pulse signal is output from the P57 terminal of the LSI at the time of cooking or the cleaning mode.

A transistor Q22 turns ON-OFF by the pulse signal from P57. Then, C21 is charged and Q21 turns on. Moreover, a "H" level is output from P07, and the O-6 terminal of IC-7 turns it on.

Consequently, relay RY3 turns on.

When a "H" level is output from the P10 terminal of the LSI, the O-5 terminal of IC-7 turns it on, and a GND level is output. RY4 turns it on, and a top heater is supplied as that result.

When a "H" level is output from the P17 terminal of the LSI, the O-5 terminal of IC-8 turns it on, and a GND level is output. The bottom heater relay turns it on, and a Bottom heater is supplied as that result.

LSI makes a heater turn ON-OFF according to the setting temperature in each mode, and performs temperature control.

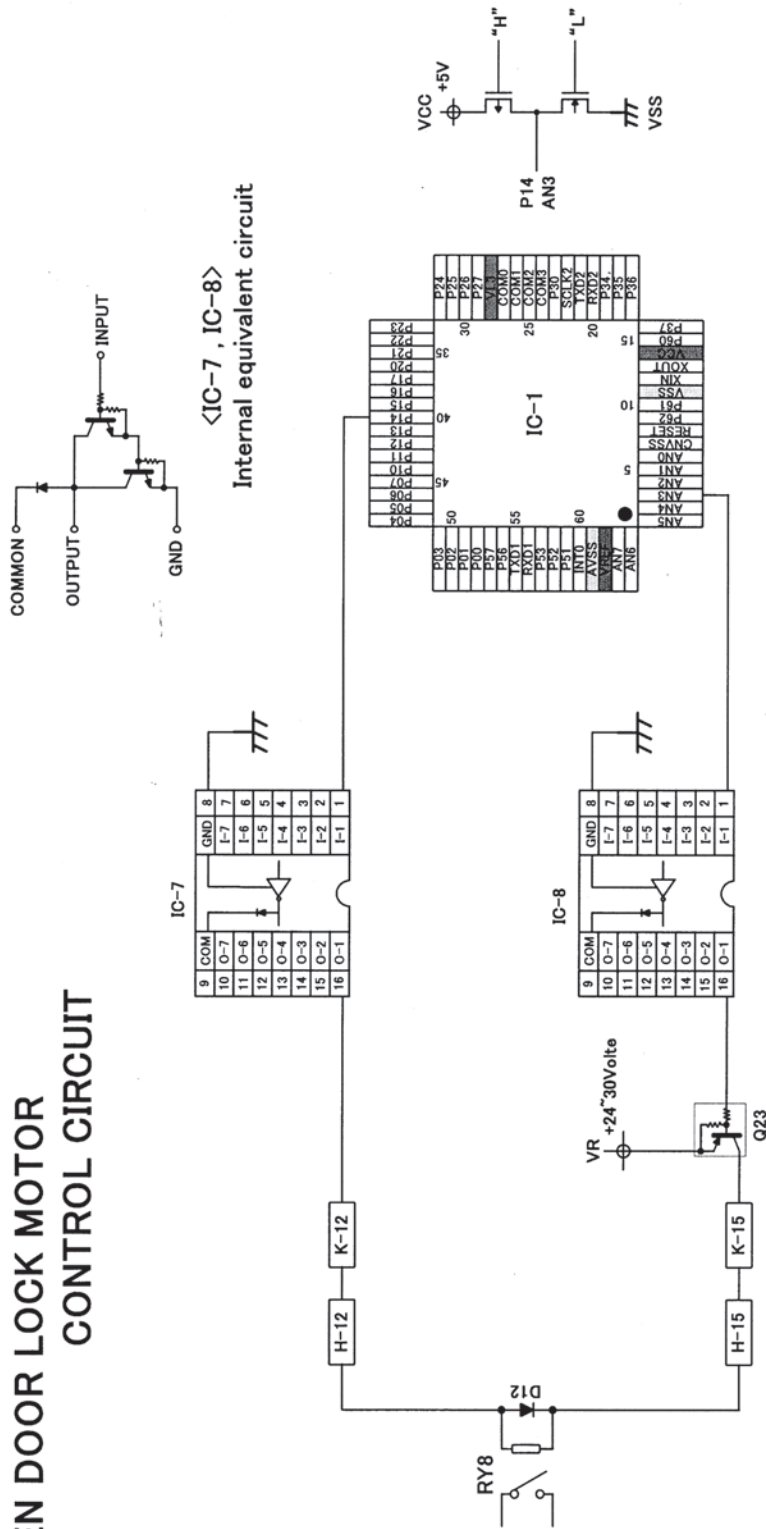
MAX TEMPERATURE : OVEN COOKING MODE 550(°F) ; SELF-CLEANING MODE 860(°F)

### <REFERENCE> THERMISTOR

TEMP (°F)	TEMP (°C)	RESISTANCE (Ω)
ICE POINT	0	1000
200	93.3	1350
350	176.7	1654
550	287.8	2047
900	482.2	2697

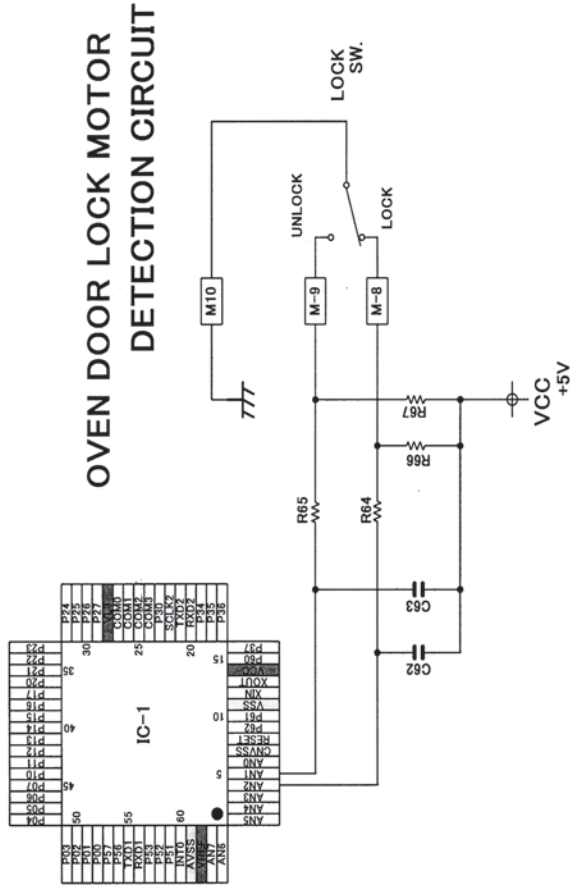
# OVEN DOOR LOCK MOTOR CONTROL CIRCUIT

## OVEN DOOR LOCK MOTOR CONTROL CIRCUIT



The signal of "H" or "L" is outputted from P14 terminal of LSI, and AN3 terminal. When "H" is output from the P14 terminal of the LSI, the O-1 terminal of IC-7 turns it on, and a GND level is output. When "H" is output from the AN3 terminal of the LSI, the O-1 terminal of IC-8 turns it on, and a GND level is output. Then, a transistor Q23 turns it on, and a VR power supply is supplied to RY8. A lock motor rotates when RY8 turns it on.

## OVEN DOOR LOCK MOTOR DETECTION CIRCUIT



The contact point composition of the Door Lock switch is "1C".

When the lock side of the switch is on, the AN2 terminal of the LSI is in the "LOW" signal. Then, an AN1 terminal is in the "HIGH" signal.

When the Unlock side of the switch is on, the AN2 terminal of the LSI is in the "HIGH" signal. Then, an AN1 terminal is in the "LOW" signal.

A surely different signal is input to the terminal of AN1 and AN2.

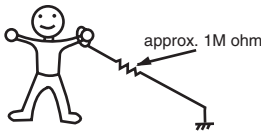
## TOUCH CONTROL PANEL SERVICING

### 1. Precautions for Handling Electronic Components

This unit uses CMOS LSI in the integral part of the circuits. When handling these parts, the following precautions should be strictly followed. CMOS LSI have extremely high impedance at its input and output terminals. For this reason, it is easily influenced by the surrounding high voltage power source, static electricity charge in clothes, etc. and sometimes it is not fully protected by the built-in protection circuit.

In order to protect CMOS LSI.

- 1) When storing and transporting, thoroughly wrap them in aluminium foil. Also wrap all PW boards containing them in aluminium foil.
- 2) When soldering, ground the technician as shown in the figure and use grounded soldering iron and work table.



### 2. Servicing of Touch Control Panel

We describe the procedures to permit servicing of the touch control panel of the microwave oven and the precautions you must take when doing so. To perform the servicing, power to the touch control panel is available either from the power line of the oven itself or from an external power source.

#### (1) Servicing the touch control panel with power supply of the oven:

##### CAUTION:

**THE HIGH VOLTAGE TRANSFORMER OF THE MICROWAVE OVEN IS STILL LIVE DURING SERVICING AND PRESENTS A HAZARD.**

Therefore, before checking the performance of the touch control panel,

- 1) Disconnect the power supply cord.
- 2) Open the drawer and block it open.
- 3) Discharge high voltage capacitor.
- 4) Disconnect the leads to the primary of the power transformer.
- 5) Ensure that these leads remain isolated from other components and oven chassis by using insulation tape.
- 6) After that procedure, re-connect the power supply cord.

After checking the performance of the touch control panel,

- 1) Disconnect the power supply cord.
- 2) Open the drawer and block it open.
- 3) Re-connect the leads to the primary of the power transformer.
- 4) Reassemble the unit.
- 5) Re-connect the power supply cord after the outer case is installed.
- 6) Run the oven and check all functions.

#### A. On some models, the power supply cord between the

touch control panel and the oven itself is so short that the two can't be separated. For those models, check and repair all the controls (sensor-related ones included) of the touch control panel while keeping it connected to the oven.

- B. On some models, the power supply cord between the touch control panel and the oven proper is long enough that they may be separated from each other. For those models, it is possible to check and repair the controls of the touch control panel while keeping it apart from the oven proper; in this case you must short both ends of the door sensing switch (on PWB) of the touch control panel with a jumper, which activates an operational state that is equivalent to the oven drawer being closed. As for the sensor-related controls of the touch control panel, checking them is possible if dummy resistor(s) with resistance equal to that of the controls are used.

#### (2) Servicing the touch control panel with power supply from an external power source:

Disconnect the touch control panel completely from the oven proper, and short both ends of the drawer sensing switch (on PWB) of the touch control panel, which activates an operational state that is equivalent to the oven door being closed. Connect an external power source to the power input terminal of the touch control panel, then it is possible to check and repair the controls of the touch control panel it is also possible to check the sensor-related controls of the touch control panel by using the dummy resistor(s).

### 3. Servicing Tools

Tools required to service the touch control panel assembly.

- 1) Soldering iron: 30W  
(It is recommended to use a soldering iron with a grounding terminal.)
- 2) Oscilloscope: Single beam, frequency range: DC-10MHz type or more advanced model.
- 3) Others: Hand tools

### 4. Other Precautions

- 1) Before turning on the power source of the control unit, remove the aluminium foil applied for preventing static electricity.
- 2) Connect the connectors of the key unit to the control unit being sure that the lead wires are not twisted.
- 3) After aluminium foil is removed, be careful that abnormal voltage due to static electricity etc. is not applied to the input or output terminals.
- 4) Attach connectors, electrolytic capacitors, etc. to PWB, making sure that all connections are tight.
- 5) Be sure to use specified components where high precision is required.

## PRECAUTIONS FOR USING LEAD-FREE SOLDER

### 1. Employing lead-free solder

The "Main PWB" of this model employs lead-free solder. This is indicated by the "LF" symbol printed on the PWB and in the service manual. The suffix letter indicates the alloy type of the solder.

Example:

**LF**a  
Sn-Ag-Cu

Indicates lead-free solder of tin, silver and copper.

### 2. Using lead-free wire solder

When repairing a PWB with the "LF" symbol, only lead-free solder should be used. (Using normal tin/lead alloy solder may result in cold soldered joints and damage to printed patterns.)

As the melting point of lead-free solder is approximately 40°C higher than tin/lead alloy solder, it is recommend that a dedicated bit is used, and that the iron temperature is adjusted accordingly.

### 3. Soldering

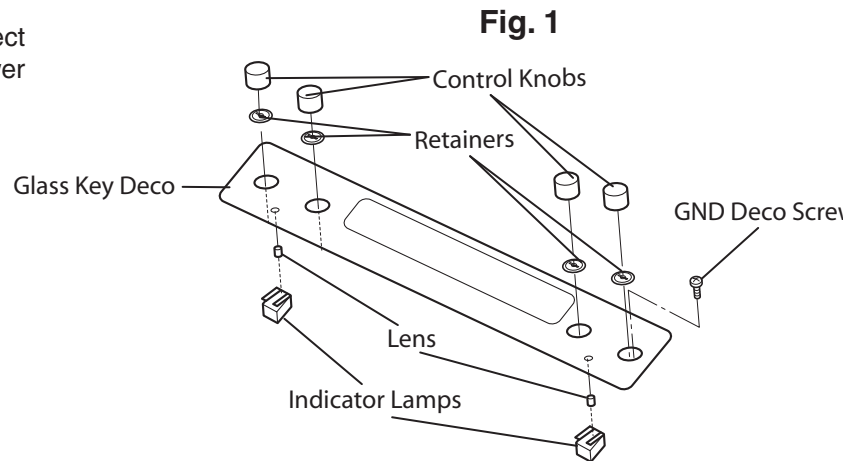
As the melting point of lead-free solder (Sn-Ag-Cu) is higher and has poorer wettability, (flow), to prevent damage to the land of the PWB, extreme care should be taken not to leave the bit in contact with the PWB for an extended period of time. Remove the bit as soon as a good flow is achieved. The high content of tin in lead free solder will cause premature corrosion of the bit. To reduce wear on the bit, reduce the temperature or turn off the iron when it is not required.

Leaving different types of solder on the bit will cause contamination of the different alloys, which will alter their characteristics, making good soldering more difficult. It will be necessary to clean and replace bits more often when

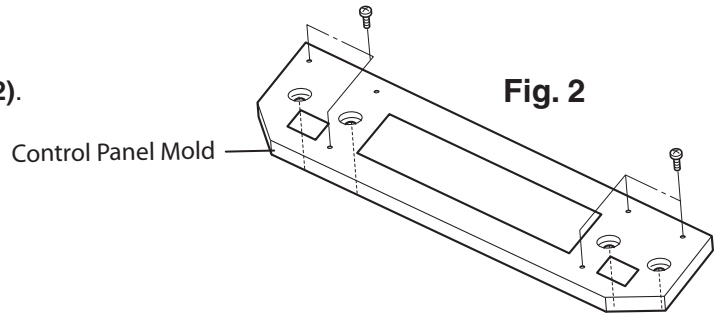
## OVEN / MICROWAVE DRAWER DISASSEMBLY

**WARNING: Follow all safety precautions beginning on Page 2 before proceeding!**

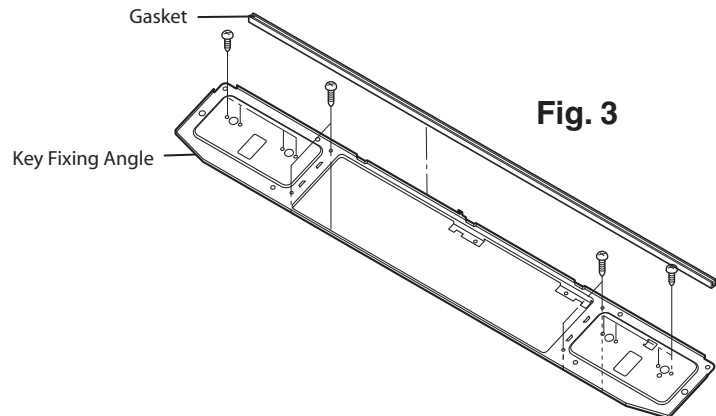
1. Before removing Control Panel, take measures to protect the Cook Top surface and keep Microwave Drawer open to prevent scratches.
2. Remove all Control Knobs (**Fig 1**).
3. Unscrew all Retainers (**Fig 1**).
4. Unscrew Glass Key Deco screw (1) (**Fig 1**).
5. Carefully lift Glass Key Deco and unhook Indicator Lamp from Lens (**Fig 1**).



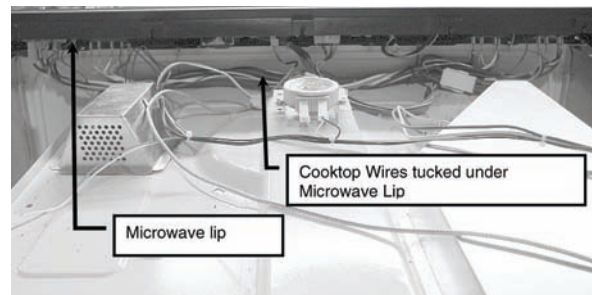
6. Remove all screws from Control Panel Mold (**Fig 2**).
7. Slide Control Panel Mold to left (to unlock) and lift (**Fig 2**).



8. Remove Gasket from Key Fixing Angle (**Fig 3**).
9. Lift Key Fixing Mold and carefully unhook all Molex's, ground wire and C/P wiring (**Fig 3**).

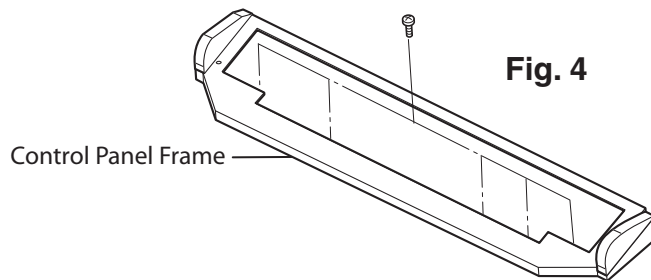


**NOTE:** When reassembling, it is very important that all Cook Top wires are tucked under the Microwave cavity lip and secured with the RED WIRE STRAP. The 240v harness can create noise that can interfere with C/P function (example: intermittent or no keyboard operation).



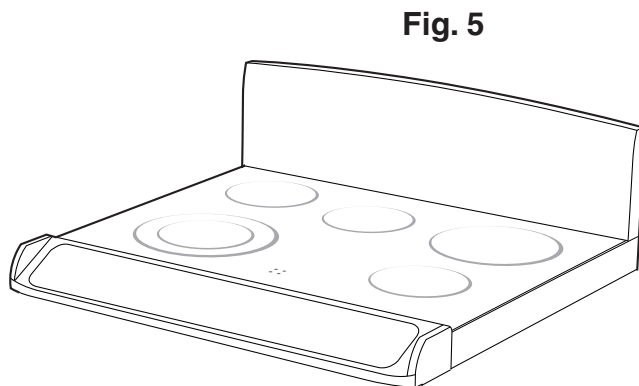
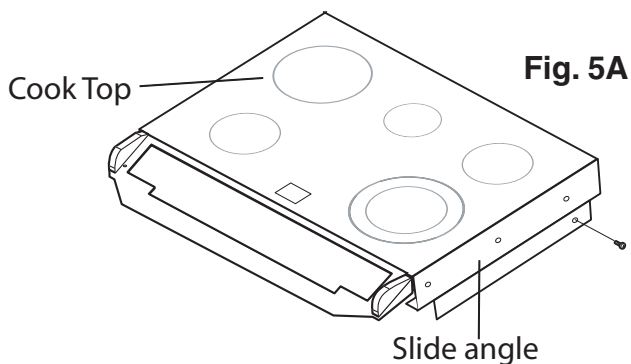


10. Remove screws from Control Panel Frame (**Fig 4**).

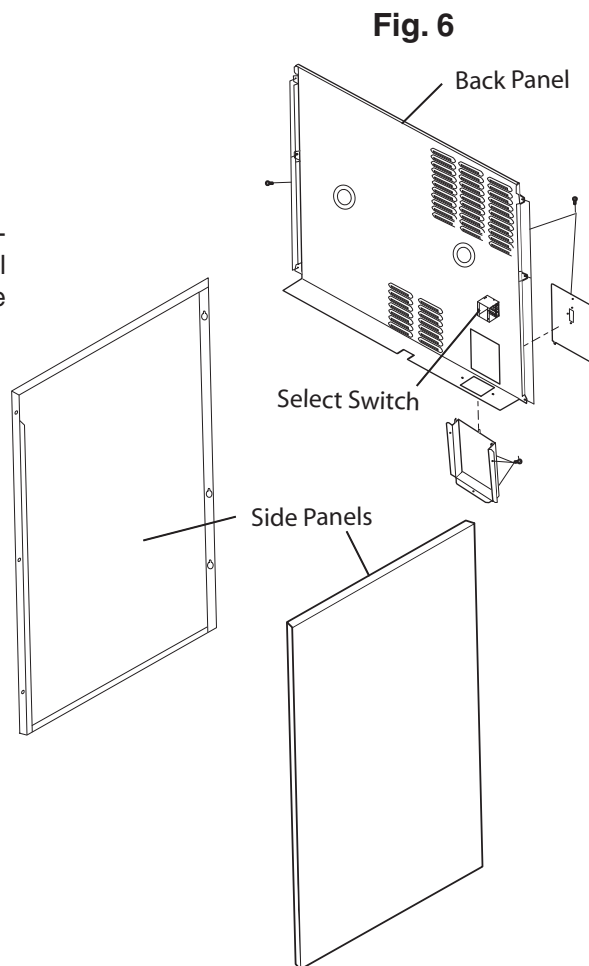


11. (**KB3425L**) - Slide Cook Top forward to unlock from shoulder screws, then remove or reposition (**Fig. 5**).

(**KB4425L**) - Before you can Slide the Cook Top forward to unlock it from shoulder screws, you must remove one screw from each right and left slide angle (**Fig. 5A**). This is done by removing the (3) screws holding the back panel to the side panels (**Fig. 6**), then carefully swing the back of the side panel out, to gain access to the screw holding each right and left slide angle.



12. Remove electrical cover and screws holding the select switch from back plate. Then remove all screws on back plate and carefully remove back/side panels (**Fig. 6**).

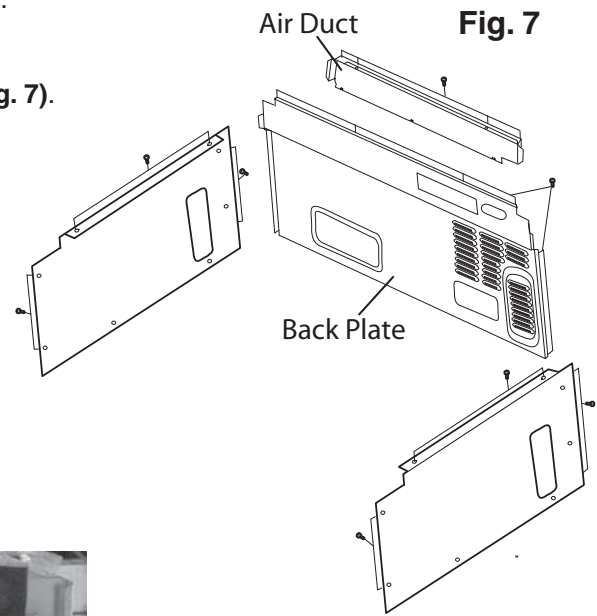


14. Remove screws from Microwave top Air Duct and take off (**Fig. 7**).
15. Remove all screws from Microwave Back Plate (**Fig. 7**).
16. Lift Back Plate and remove carefully not to damage any wires (**Fig. 7**).

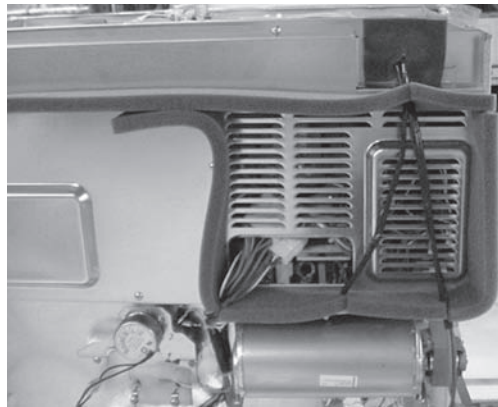
**NOTE:**

The Microwave Back Plate cannot be completely removed due to wiring. If you need to remove, you will have to unhook all wiring routed through it.

Also, the cushion placement is very important and must be replaced if damaged during removal (**Fig. 8**).



**Fig. 8**



**At this point, you will have access to all parts of the Microwave and Oven.**

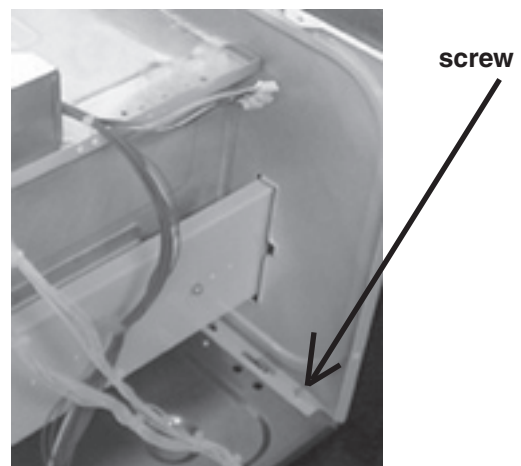
## MICROWAVE DRAWER ASSEMBLY REMOVAL TO ACCESS OVEN COMPONENTS

### OVEN COMPONENT REMOVAL

1. After disassembly as previously stated, remove Microwave Drawer assembly by removing (2) screws (**right & left**) from front of Microwave Baseplate (**Fig. R-1**).
2. Unhook wires from Range Oven to Microwave Drawer, remove Drawer assembly from Oven.

**You now have access to Range Oven components.**

**Fig. R-1**



## STOP SWITCH, SECONDARY INTERLOCK SWITCH AND MONITOR SWITCH REMOVAL

2. Disconnect the power supply cord.
3. To discharge the high voltage capacitor, wait for 60 seconds.
4. Remove the Cook Top.
5. Remove the Cook Top Stay (right or left).
6. Remove the screw holding the latch hook to the oven flange.
7. Remove the latch hook from the oven flange.
8. Disconnect the wire leads of each switch.
9. Remove each switch from the latch hook by pushing the one (1) stopper tab holding each switch.
10. Now, each switch is free.

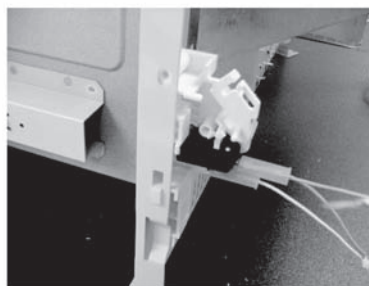
### Re-install

1. Re-install each switch in its place. The secondary interlock switch is in the lower position and the monitor switch is in the top position, located on the left side of the unit. The door sensing switch by itself on the right side of the unit.
2. Re-connect wire leads to each switch. Refer to pictorial diagram.
3. Secure the latch hooks with mounting screws to oven flange.
4. Make sure that the monitor switch is operating properly and check continuity of the monitor circuit. Refer to chapter "Test Procedure" and "Adjustment procedure".

Latch Hook Left



Latch Hook Right



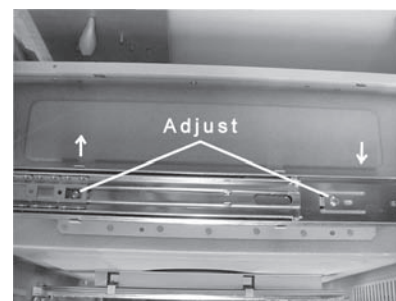
## STOP SWITCH, SECONDARY INTERLOCK SWITCH AND MONITOR SWITCH ADJUSTMENT

1. Disconnect the power supply cord.
2. Open the drawer and keep it open.
3. To discharge the high voltage capacitor, wait for 60 seconds.
4. Remove the Cook Top.
5. Remove the Cook Top Stay (right or left). If the door sensing switch, secondary interlock switch and monitor switch do not operate properly due to a misadjustment, the following adjustment should be made.
6. Loosen the screw holding latch hook to the oven cavity flange.
7. With drawer closed, adjust latch hook by moving it back and forth, and up and down. In and out play of the door allowed by the upper and lower position of the latch hook should be less than 0.5mm. The vertical position of the latch hook should be adjusted so that the secondary interlock switch is activated with the drawer closed. The horizontal position of the latch hook should be adjusted so that the monitor switch and drawer sensing switch are activated with the drawer closed.
8. Secure the screws with washers firmly.
9. Check all of the switches operation. If any switch has not activated fully, you will need to adjust the slide rail attached to the Microwave cavity.
10. This is done by following the steps to remove the "DRAWER/SLIDE RAIL REMOVAL" on page 42. After you have removed the slide rails, loosen the "2" screws holding the slide rail to the Microwave cavity and tilt the front end up and the rear end down, then tighten the screws (**Fig. S-1**).
11. Check and assure that the cap nuts on the Drawer Support Angles are centered when passing through the cavity face plate.

### After adjustment, check the following.

1. In and out play of door remains less than 0.5mm when in the latched position. First check upper position of latch hook, pushing and pulling upper portion of drawer toward the oven face. Then check lower portion of the latch hook, pushing and pulling lower portion of the door toward the oven face. Both results (play in the door) should be less than 0.5mm.
2. The secondary interlock switch switch interrupt the circuit before the door can be opened.
3. Monitor switch contacts close when door is opened.
4. Door sensing switch contacts open when door is opened.
5. Reassemble the unit and check for microwave leakage around door with an approved microwave survey meter. (Refer to Microwave Measurement Procedure.)

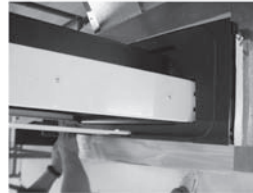
Fig. S-1



## DRAWER/SLIDE RAIL REMOVAL

### DRAWER ASSEMBLY AND CHOKE REMOVAL

1. Disconnect the power supply cord.
2. Open the drawer and keep it open.
3. To discharge the high voltage capacitor, wait for 60 seconds.
4. Remove the both right and left Cook Top Stays.
5. Remove (2) Drawer Support Covers from Choke Cover as shown in **(Fig. D-1)**.
6. Insert a putty knife (thickness of about 0.5mm) into the gap between the choke cover and the door frame.
7. Carefully slide choke cover away from drawer as far as possible.
8. Remove (6) screws from all (3) drawer Support Angles as shown in **(Fig. D-2)**.
9. Unhook Drawer Support Angles from drawer, then remove.
10. Now, the door assembly is free and the Choke Cover can now be removed.



### NOTE:

To remove only the Microwave Drawer, follow steps 1, 2, 5, 8, 9 & 10 as instructed under "DRAWER ASSEMBLY AND CHOKE REMOVAL".

### DRAWER SUPPORT ANGLE REMOVAL

1. Remove Drawer Assembly and Choke Cover as stated in "DRAWER ASSEMBLY AND CHOKE REMOVAL".
2. Remove (2) screws from right or left Latch Angle Assembly, then remove Angle assembly **(Fig. D-4)**.
3. Separate Slide Rails by moving inside lever of Slide Rails. The Slide Rail will now separate by pulling straight forward and out **(Fig. D-3)**.
4. At this point, you can replace either Latch Angle Assy or Latch Angles.

To reassemble, just reverse the above order.

After reassembly, do the following.

- (A) Make sure that drawer sensing switch, secondary interlock switch and monitor switch are operating properly. (Refer to chapter "Test Procedures".)
- (B) An approved microwave survey meter should be used to assure compliance with proper microwave radiation emission limitation standards.

After any servicing, make sure of the following :

1. Drawer latch heads smoothly catch latch hook through latch holes and that latch head goes through center of latch hole.
2. Deviation of door alignment from horizontal line of cavity face plate is to be less than 1.0mm.
3. Drawer is positioned with its face pressed toward cavity face plate.
4. Reassemble the unit and check for microwave leakage around drawer with an approved microwave survey meter. (Refer to Microwave Measurement Procedure.)

**Note:** The drawer on a microwave oven is designed to act as an electronic seal preventing the leakage of microwave energy from oven cavity during cook cycle. This function does not require that door be air-tight, moisture (condensation)-tight or light-tight. Therefore, occasional appearance of moisture, light or sensing of gentle warm air movement around oven drawer is not abnormal and do not of themselves indicate a leakage of microwave energy from oven cavity.

Fig. D-2

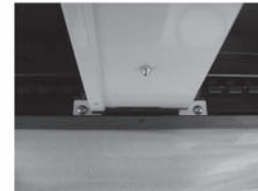
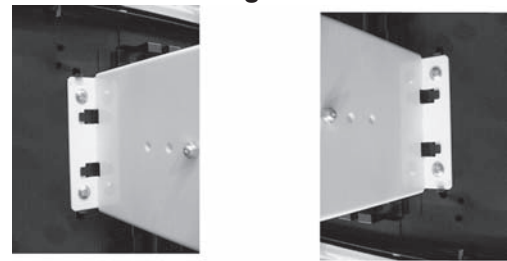


Fig. D-3



Fig. D-4



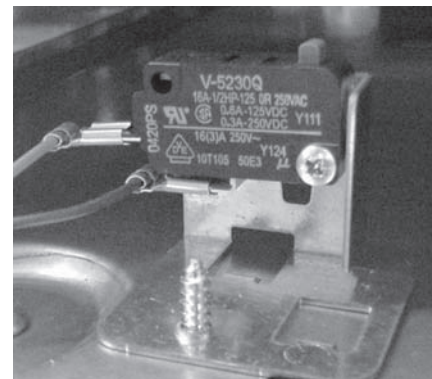
## SWITCH ANGLE REMOVAL/ADJUSTMENT

### SWITCH ANGLE REMOVAL

(Locate either the right or left switch angle)

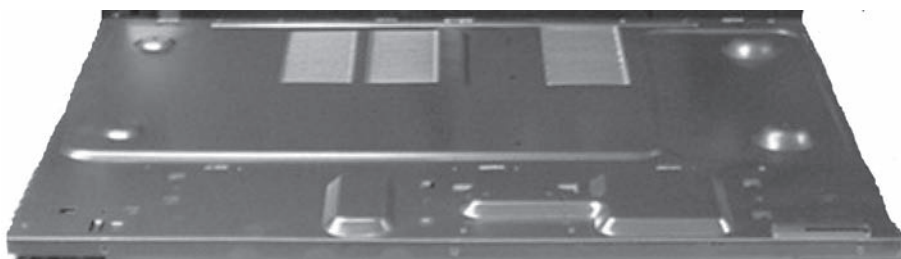
1. Follow the Microwave Drawer disassembly as previously stated.
2. Open the drawer and keep it open.
3. To discharge the high voltage capacitor, wait for 60 seconds.
4. To remove switch, remove screw (1) holding switch to switch angle (**Fig. S-1**).

**Fig. S-1**



5. To replace switch angle, remove bottom cover and remove the 2 screws holding the switch lever (**Fig. S-2**).
6. Proceed in reverse to reinstall.
7. Adjust switch.

**Fig. S-2**



## ACTUATOR REMOVAL/ADJUSTMENT

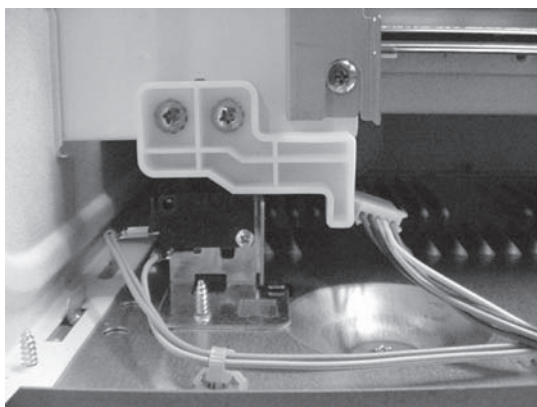
1. Follow the Microwave Drawer disassembly as previously stated.
2. Open the drawer and keep it open.
3. To discharge the high voltage capacitor, wait for 60 seconds.
4. Locate either the right or left actuator and remove the 2 screws holding the actuator to the door support angles.
5. Replace with the new actuator (**Fig. A-3**).

### Actuator adjustment

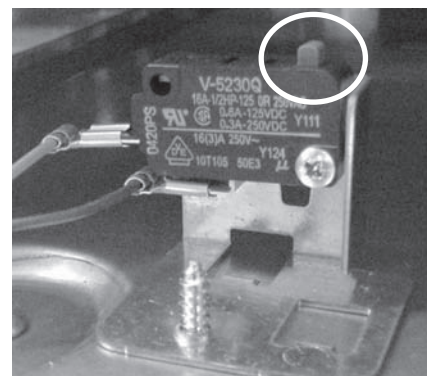
6. It is very critical that proper adjustment is made to actuator.
7. Adjust each actuator to fully depress ("0" gap) switch lever switches on left and right side (**Fig. A-4**).

**NOTE:** If this adjustment is not adjusted correctly, it will effect the performance of the Auto Drawer.

**Fig. A-3**

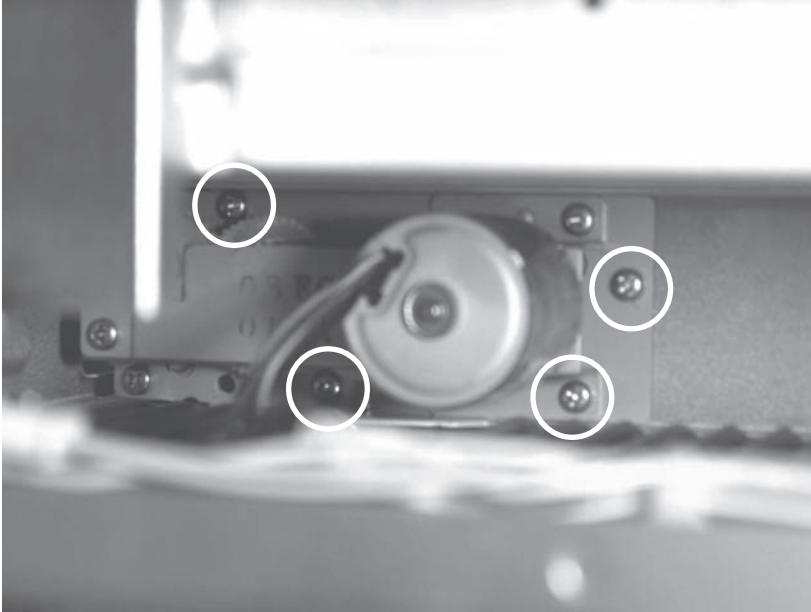


**Fig. A-4**



## AUTO DRAWER GEAR REMOVAL

1. Follow the Microwave Drawer disassembly as previously stated.
2. Open the drawer and keep it open.
3. To discharge the high voltage capacitor, wait for 60 seconds.
4. Unhook wiring Auto Drawer Gear.
5. Remove the (4) screws holding the auto drawer gear to the bottom cavity angle (**Fig. G-1**).
5. Pull drawer gear from cavity angle.
6. The drawer gear is now free.
7. Proceed in reverse to reinstall the Auto Drawer Gear taking care that the gear teeth are set into the cavity angle correctly.



**Fig. G-1**

## RACK GEAR REMOVAL

1. Follow the Microwave Drawer disassembly as previously stated.
2. Open the drawer and keep it open.
3. To discharge the high voltage capacitor, wait for 60 seconds.
4. Remove the Microwave Drawer by following steps 1, 2, 5, 8, 9 & 10 as instructed under "DRAWER ASSEMBLY AND CHOKE REMOVAL".
5. Remove the (3) screws holding the Rack Gear to the bottom slide rail (**Fig. G-2**).
7. Proceed in reverse to reinstall the new Rack Gear.



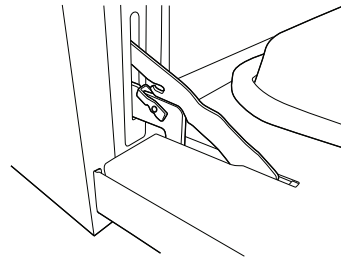
**Fig. G-2**

## OVEN DOOR REMOVAL

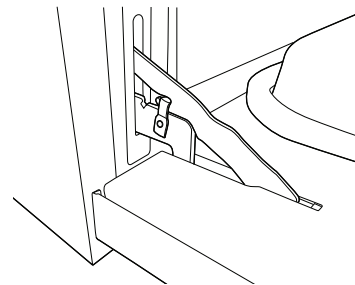
### OVEN DOOR ASSEMBLY REMOVAL

1. Disconnect the power supply cord.
2. Open the door to the fully opened position (**Fig. O-1**).
3. Pull the lock located on both hinge supports up and engage in the hook of the hinge levers. You may have to apply a little downward pressure on the door to pull the locks fully over the hooks (**Fig. O-2**).
4. Grab the door by the sides, pull the bottom of the door up and toward you to disengage the hinge supports. Keep pulling the bottom of the door toward you while rotating the top of the door toward the range to completely disengage the hinge levers (**Fig. O-3**).
5. Proceed in reverse to reinstall the door.
6. Make sure the hinge supports are fully engaged before unlocking the hinge levers.

**Fig. O-1**



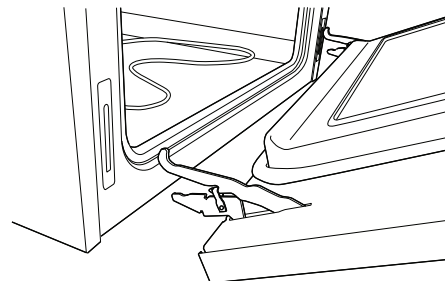
**Fig. O-2**



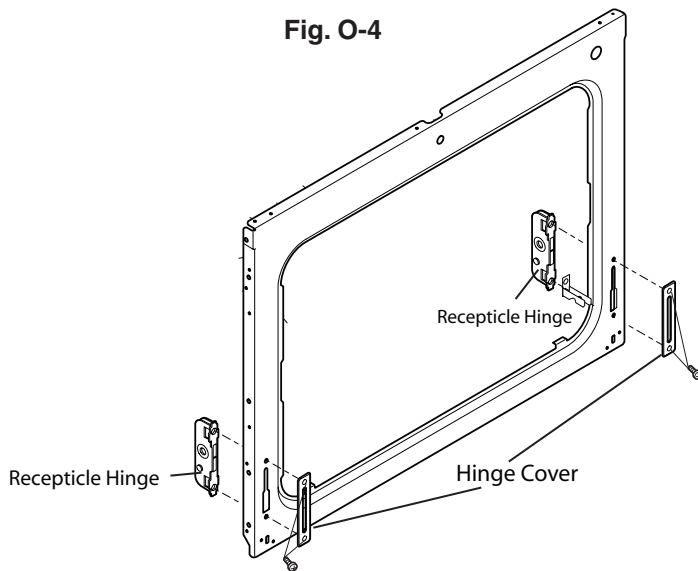
### OVEN DOOR RECEPTACLE HINGE AND HINGECOVER REPLACEMENT

1. Disconnect the power supply cord.
2. Refer to the disassembly instructions as previously stated.
3. Remove (2) screws from Hinge Cover (**Fig. O-4**)
4. Remove Hinge Receptacle.
5. Proceed in reverse to reinstall the Hinge Receptacle and Hinge Cover.

**Fig. O-3**



**Fig. O-4**



## OVEN BAKE ELEMENT REMOVAL

1. Disconnect the power supply cord.
2. Refer to the disassembly instructions as previously stated.
3. Disconnect the wires by removing (2) nuts from element (**Fig. O-5**)
4. Remove the (2) screws holding the element from inside the oven (**Fig. O-6**).
5. Pull the Element into the oven.
6. Proceed in reverse to reinstall the Bake Element.

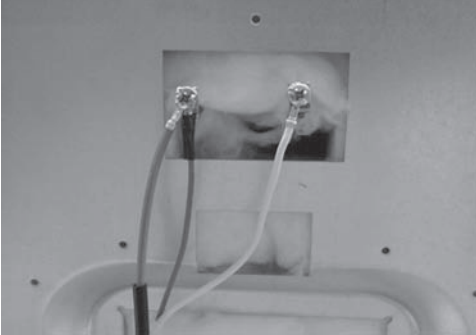


Fig. O-5



Fig. O-6

## OVEN BROIL ELEMENT REMOVAL

1. Disconnect the power supply cord.
2. Refer to the disassembly instructions as previously stated.
3. Disconnect the wires by removing (2) nuts from element (**Fig. O-7**)
4. Remove the (2) screws holding the element from inside the oven (**Fig. O-8**).
5. Pull the Element into the oven.
6. Proceed in reverse to reinstall the Broil Element.

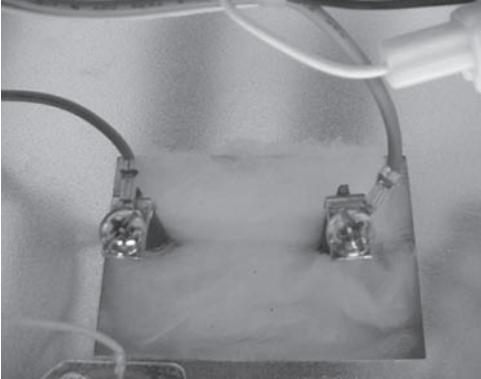


Fig. O-7

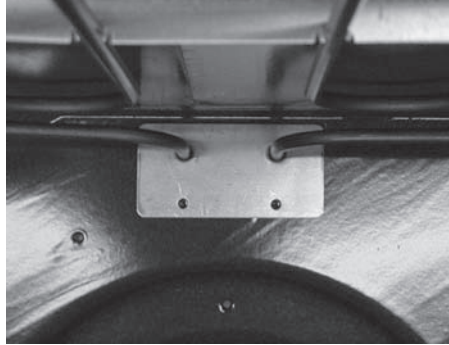


Fig. O-8

## THERMISTOR REMOVAL

1. Disconnect the power supply cord.
2. Refer to the disassembly instructions as previously stated.
3. Unhook rear Molex wiring from Thermistor (**Fig. O-9**)
4. Remove tape from Thermistor rear hole.
5. Remove the (2) screws holding the Thermistor from inside the oven (**Fig. O-10**).
6. Pull the Thermistor into the oven.
7. Proceed in reverse to reinstall the Thermistor.



Fig. O-9

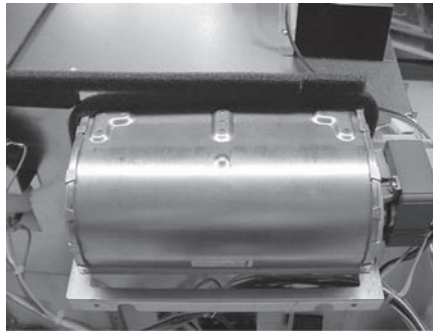


Fig. O-10



## BLOWER MOTOR REMOVAL

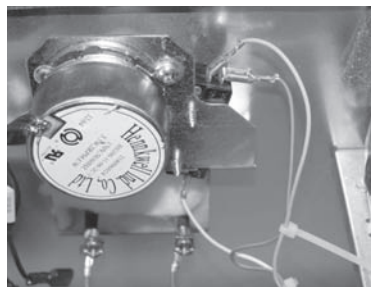
1. Disconnect the power supply cord.
2. Refer to the disassembly instructions as previously stated.
3. Unhook all wiring from Blower Motor (**Fig. O-11**)
4. Remove tape from Thermistor rear hole.
5. Remove the (2) screws holding the Blower Motor to the Rear Plate.
6. The Blower Motor is now free.
7. Proceed in reverse to reinstall the Blower Motor.



**Fig. O-11**

## LOCK MOTOR REMOVAL

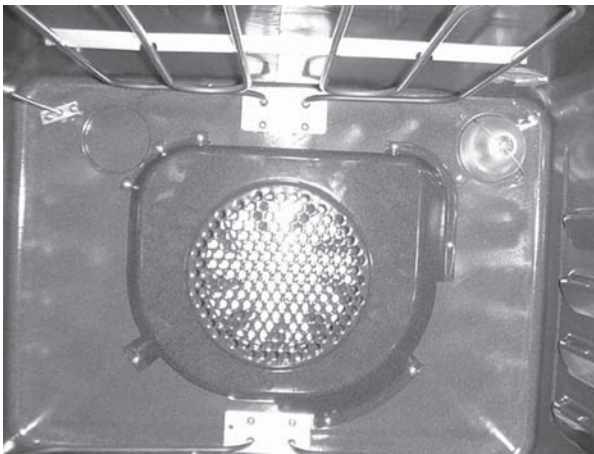
1. Disconnect the power supply cord.
2. Refer to the disassembly instructions as previously stated.
3. Unhook all wiring from Lock Motor (**Fig. O-12**).
4. Remove the (2) screws holding the Lock Motor to the Rear Plate.
5. Pull Lock Motor from Lock Motor Shaft.
6. The Lock Motor is now free.
7. Proceed in reverse to reinstall the Lock motor.



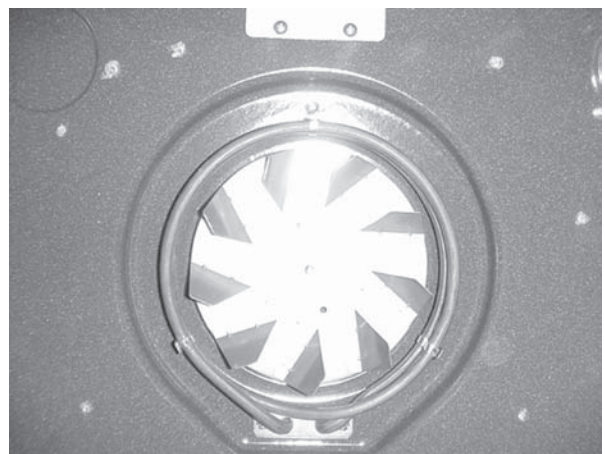
**Fig. O-12**

## CONVECTION MOTOR/IMPELLER BLADE REMOVAL

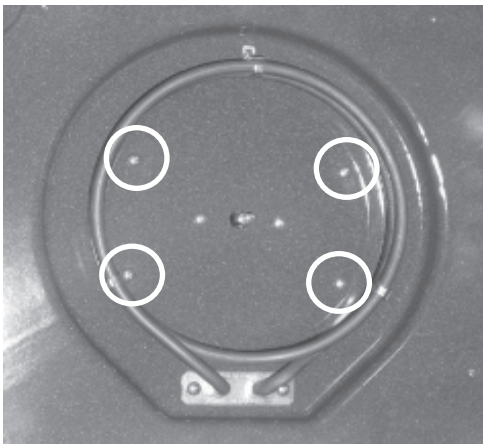
1. Disconnect the power supply cord.
2. Refer to the disassembly instructions as previously stated.
3. Unhook all wiring from convection Motor (**Fig. C-16**).
4. Remove the (8) screws holding the convection cover on from inside the oven (**Fig. C-13**).
5. Remove the (2) screws holding the convection heater in place (if necessary) (**Fig. C-14**).
6. Unscrew the convection fan nut by turning it clockwise (**Fig. C-14**).
7. Once the convection blade is removed, unscrew the (4) screws holding the convection motor in place (**Fig. C-15**).
8. The Lock Motor is now free.
9. Remove the "E" retaining clip and (2) washers holding the impeller blade on to the convection motor shaft (**Fig. C-16**).



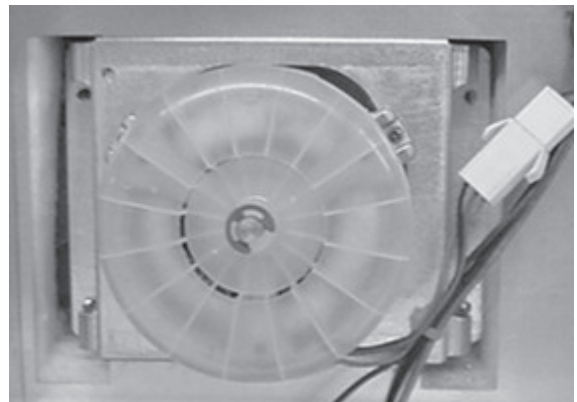
(Fig. C-13)



(Fig. C-14)



(Fig. C-15)



(Fig. C-16)

## COOK TOP RADIANT HEATERS/HOT SURFACE INDICATOR REMOVAL

1. Disconnect the power supply cord.
2. Refer to the disassembly instructions as previously stated.
3. After Cook Top Assembly is free, turn upside down (glass side down) on a protective surface to prevent scratching (**Fig. O-13**).
4. Remove the (10) screws from Bottom Plate and place to the side.
5. Remove Heater Protect Cover (**Fig. O-14**).
6. Remove necessary spring strap from Radiant Element.
7. Unhook Radiant Element or Hot Surface Indicator wiring.
8. The Radiant Elements are now free.
9. Proceed in reverse to reinstall the Radiant Elements and/or Hot Surface Indicator.



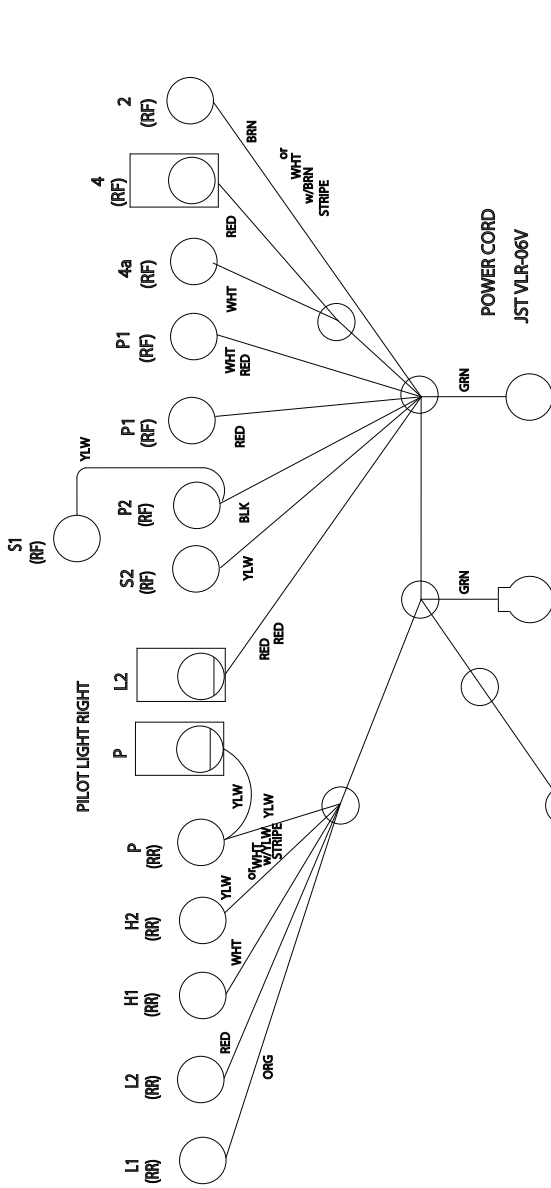
Fig. O-13



Fig. O-14

# CONTROL PANEL WIRING DIAGRAM

INFINITE SWITCHES (RIGHT SIDE)



VLR-12V  
(TO COOKTOP HARNESS)

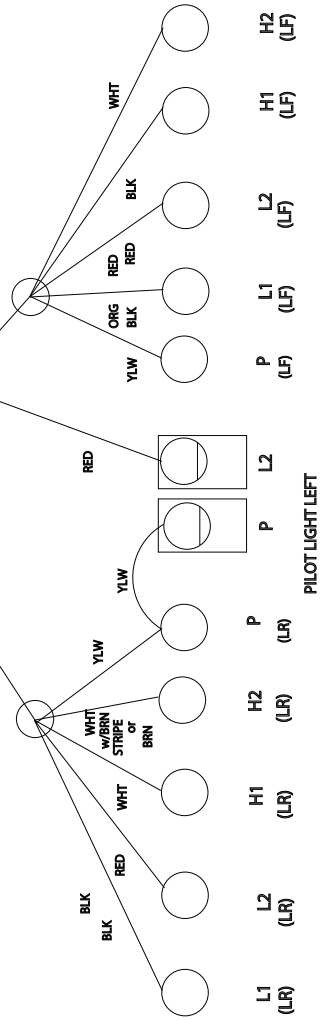
1	BLK
2	WHT
3	RED
4	WHT
5	WHT
6	BLK
7	WHT
8	
9	
10	WHT
11	
12	

L1	BLK
L2	WHT
4 (RF)	RED
4a(RF)	WHT
H1(RR)	WHT
H1(LF)	BLK
H1(LR)	WHT
H2(RR)	WHT w/BRN STRIPE or BRN
H2(LF)	WHT w/YLW STRIPE or YLW
H2(LR)	WHT w/BRN STRIPE or BRN

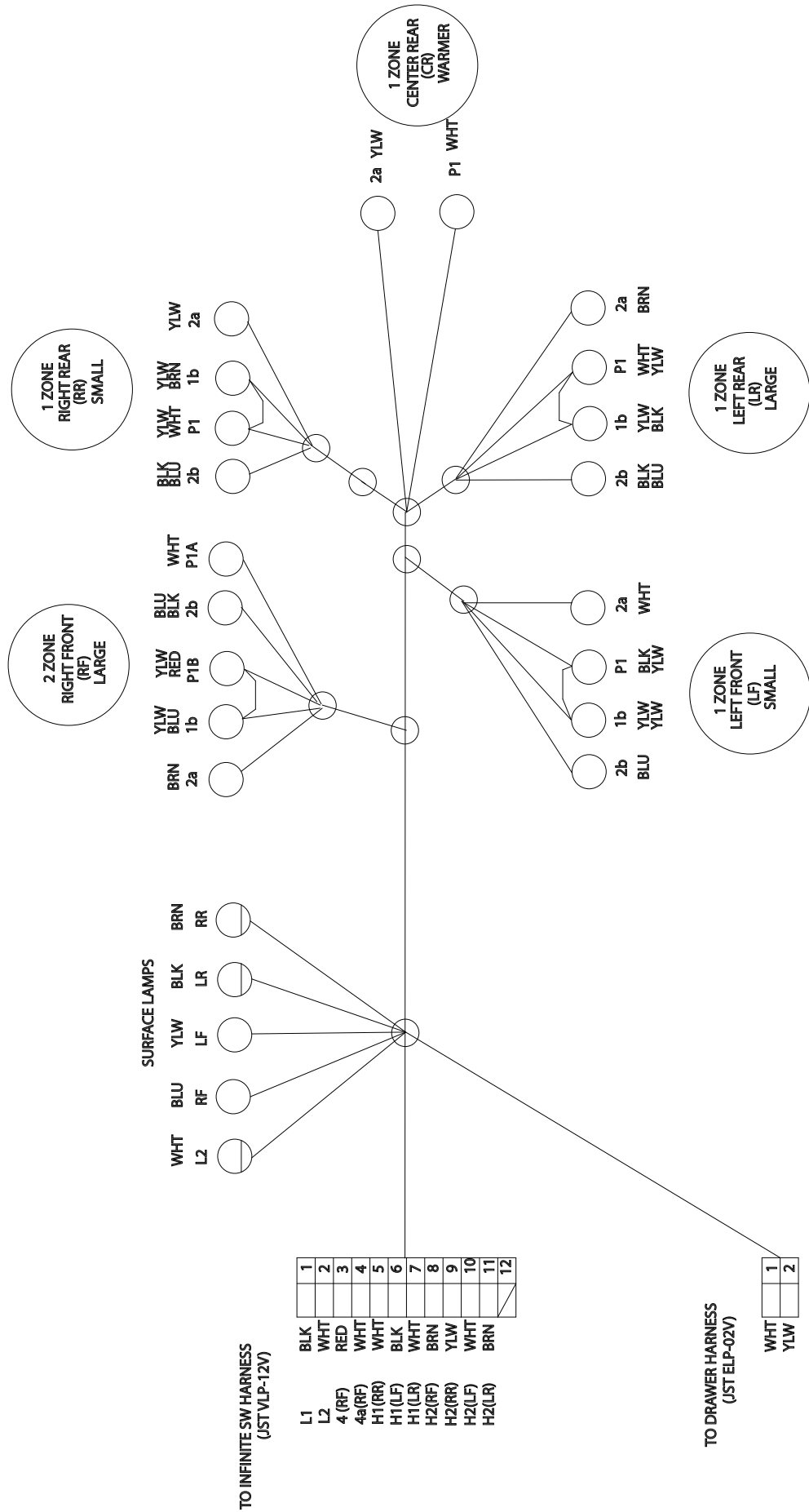
POWER CORD  
JST VLR-06V

1	BLK	L1
2	BLK	L1
3	BLK	L1
4	RED	L2
5	RED	L2
6	RED	L2

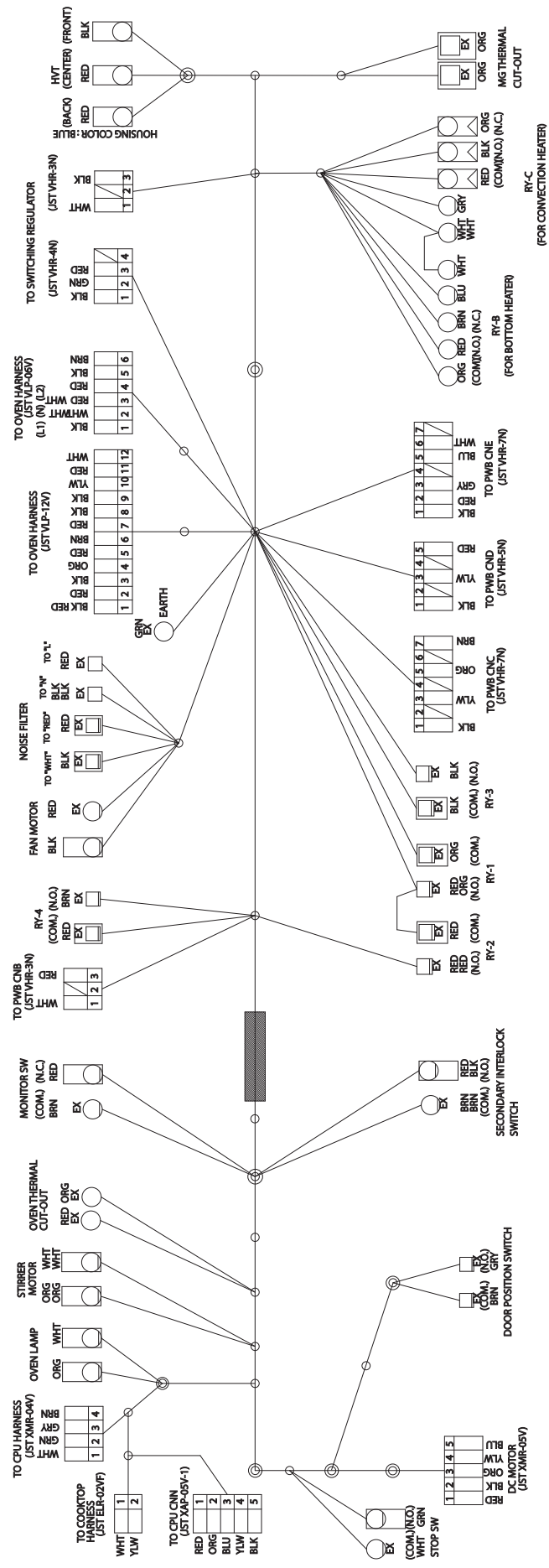


INFINITE SWITCHES (LEFT SIDE)

# COOK TOP WIRING DIAGRAM

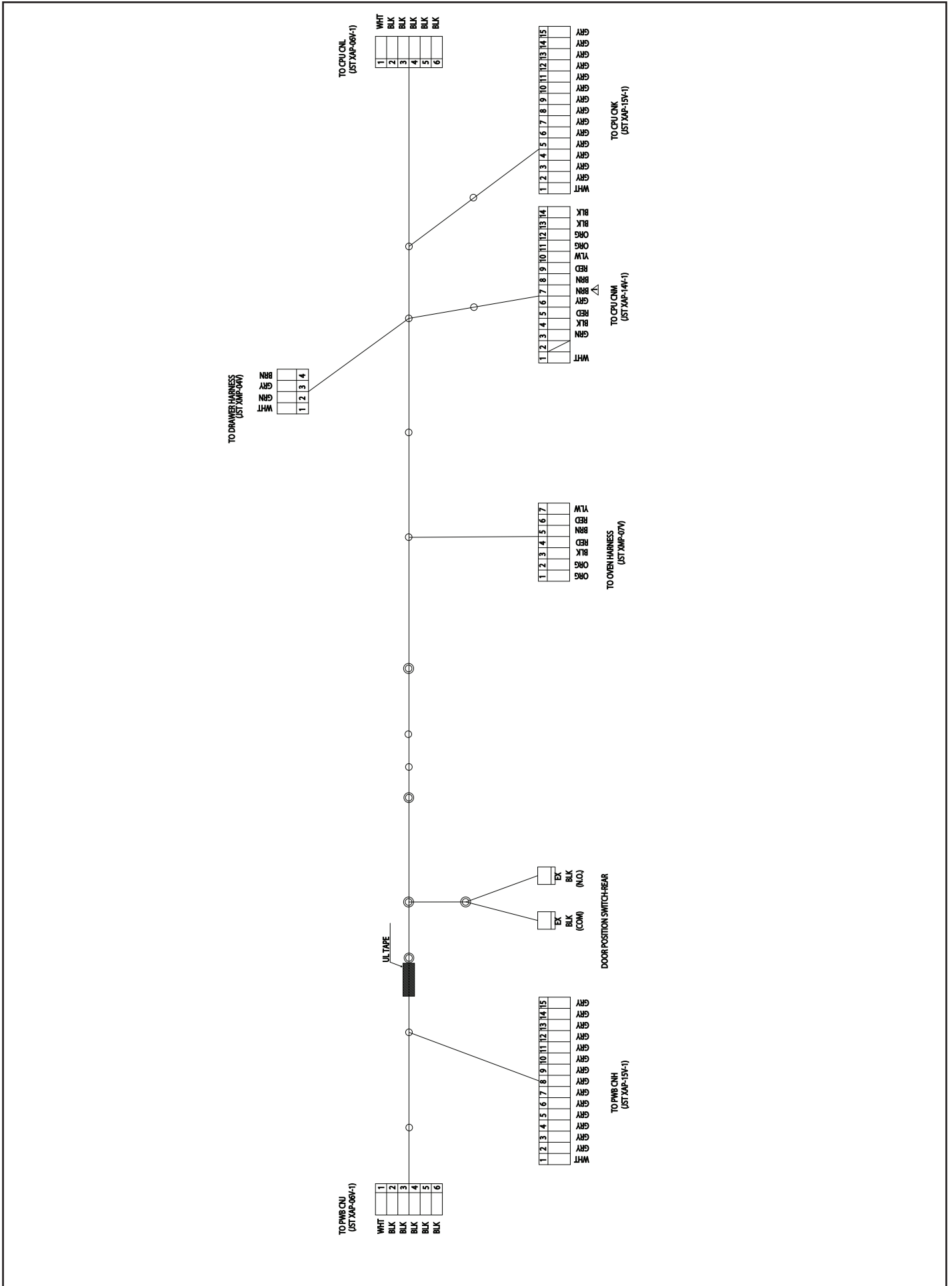


# MICROWAVE DRAWER WIRING DIAGRAM

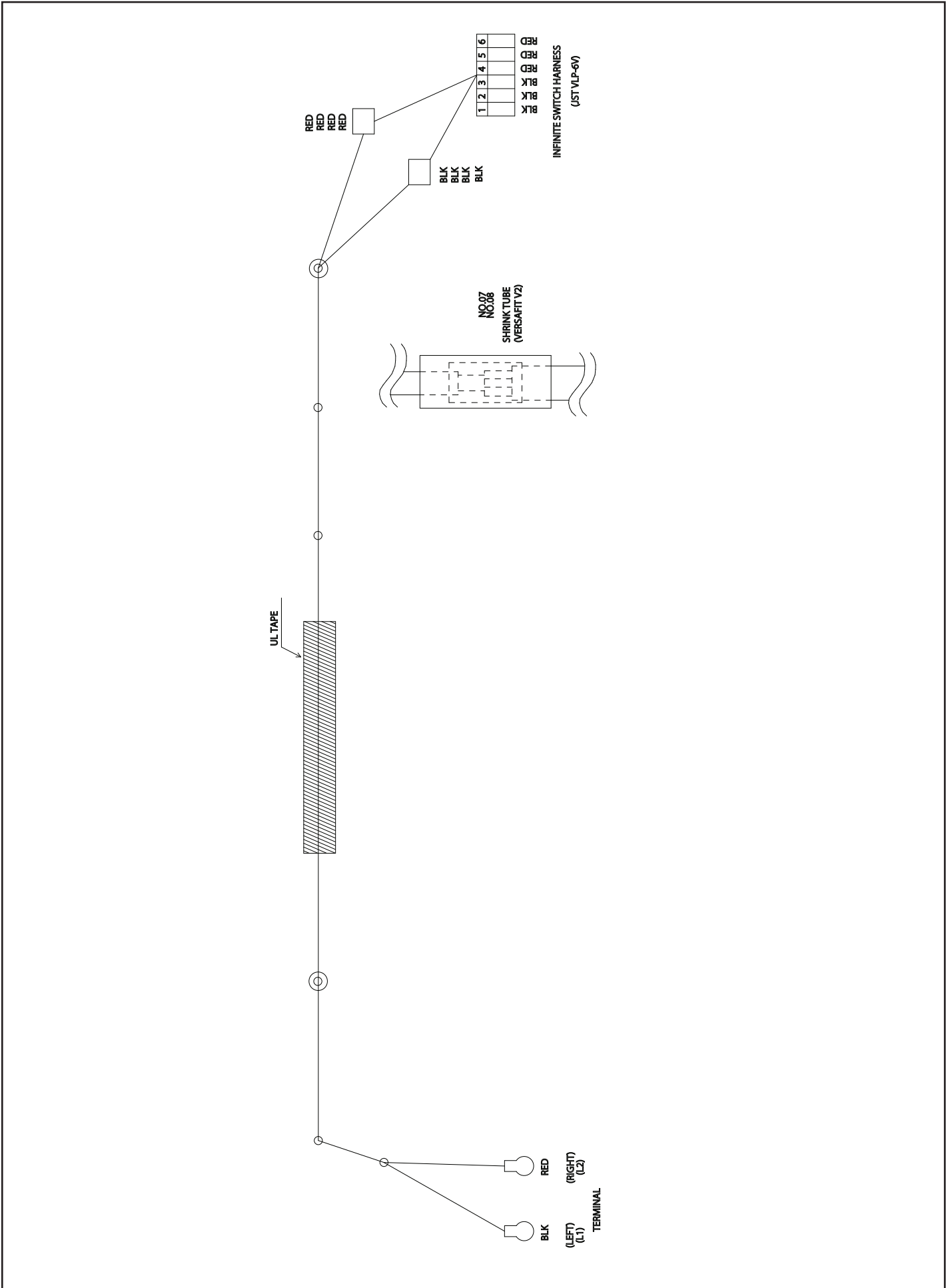


# MICROWAVE DRAWER CPU WIRING DIAGRAM

KB-3425LS/K/W  
KB-4425LS/K/W

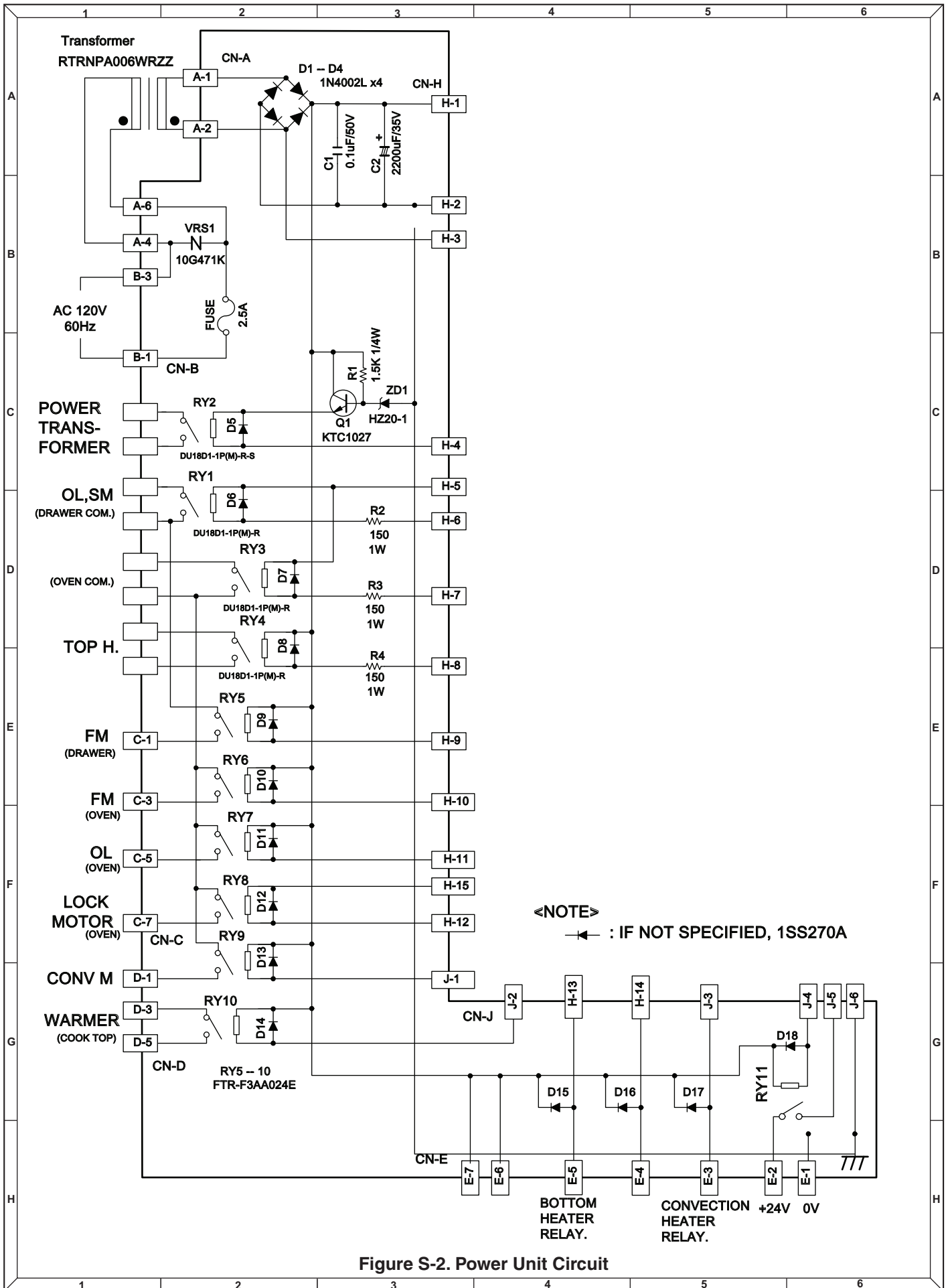


# RANGE POWER SUPPLY WIRING DIAGRAM









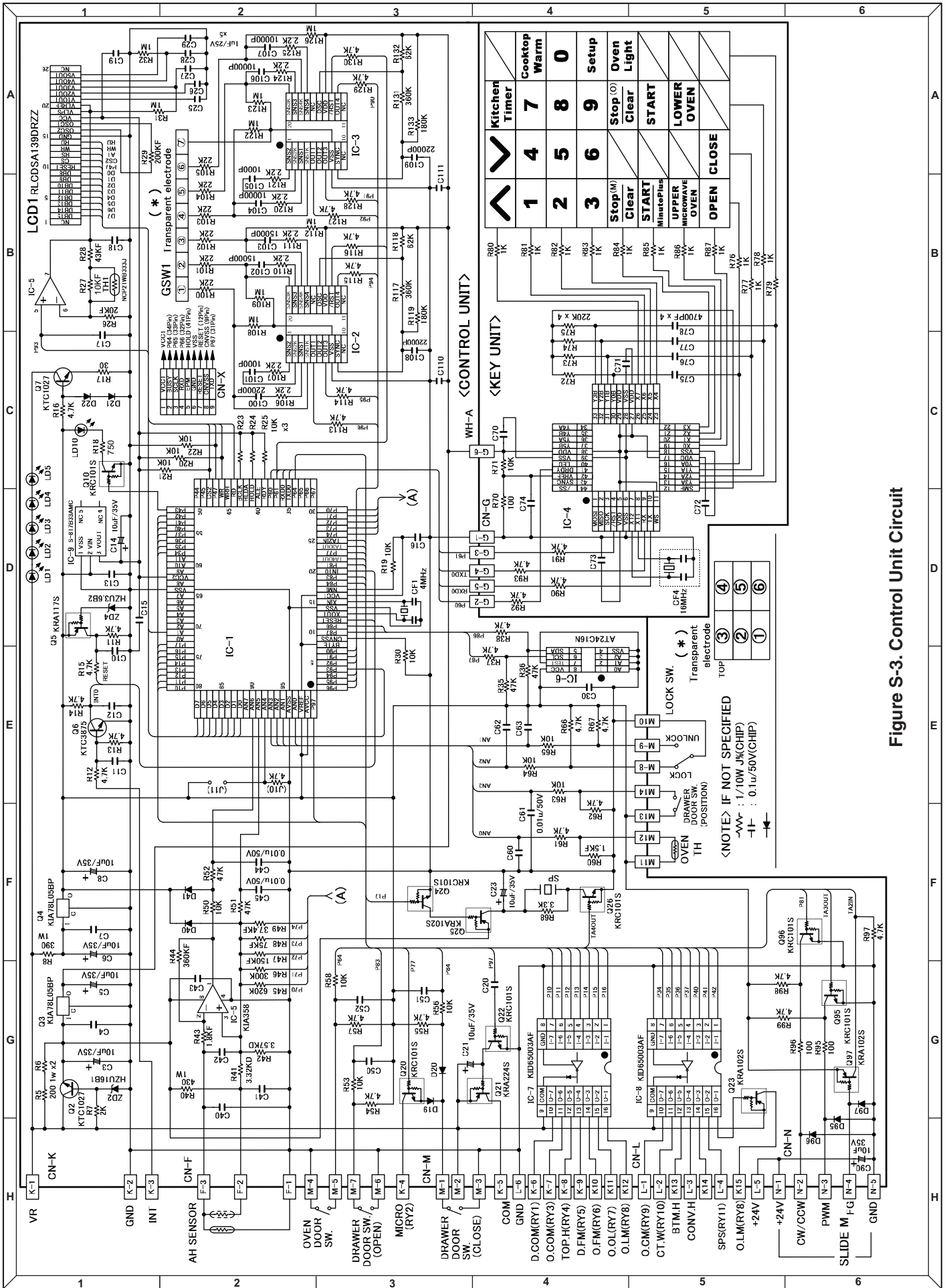


Figure S-3. Control Unit Circuit





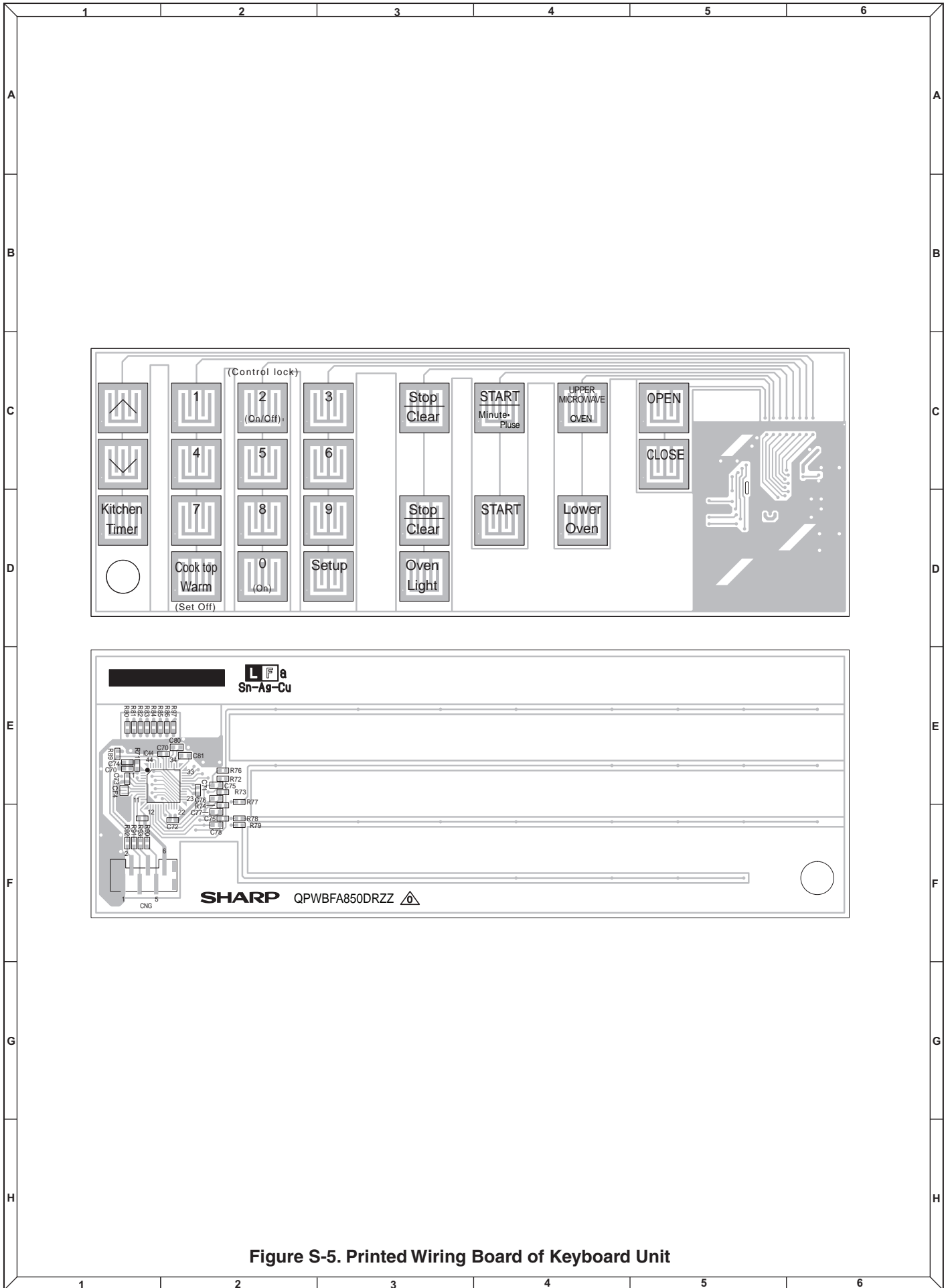


Figure S-5. Printed Wiring Board of Keyboard Unit

## CONTROL PANEL PARTS LIST

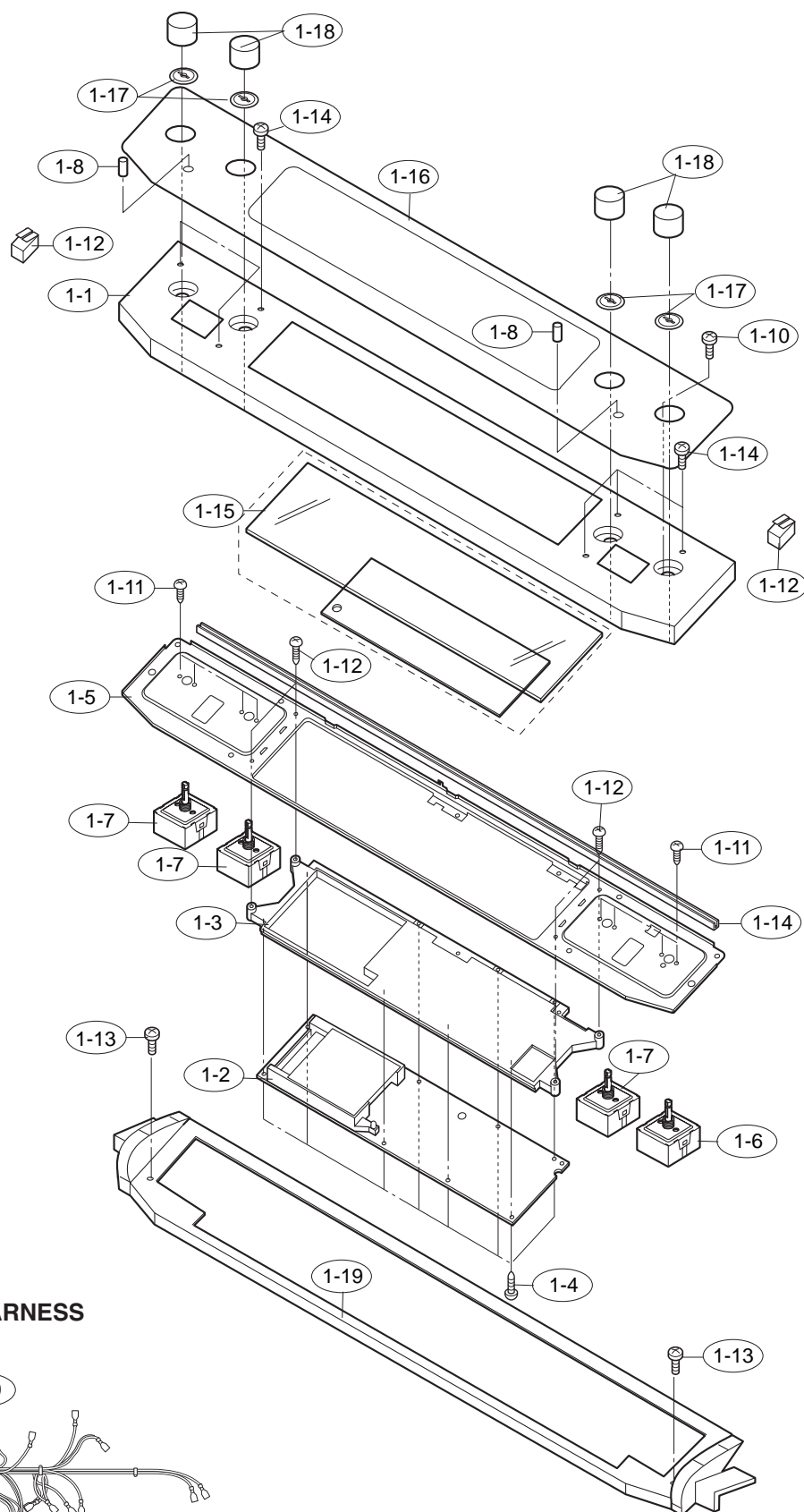
Note: The parts marked "△" may cause undue microwave exposure.

The parts marked "\*" are used in voltage more than 250V.

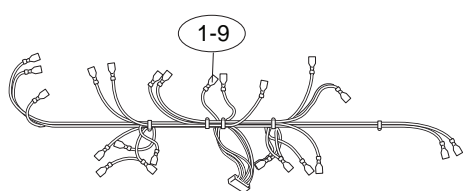
"§" MARK: PARTS DELIVERY SECTION

REF. NO.	PART NO.	§	DESCRIPTION	Q'TY	CODE
1- 1	HPNLCB200MRF0	M	Control panel mold	1	AS
1- 2	DPWBFB132MRU3	M	Control unit	1	CB
1- 3	LHLD-B029MRF0	M	PWB holder	1	AN
1- 4	XEPS730P08XS0	M	Screw : 3mm x 8mm	8	AA
1- 5	LANGQB072MRP0	M	Key fixing angle	1	AN
1- 6	QSWTEB002MRE0	M	Double control	1	AW
1- 7	QSWTEB006MRE0	M	Infinite switch	3	AT
1- 8	PLNS-B003MRE0	M	Lens	2	AA
1- 9	FW-VZB259MRE0	M	C/P harness	1	BA
1-10	XBTWW40P06000	M	Screw : 8mm x 6mm	8	AA
1-11	XCTSD40P08000	M	Screw : 8mm x 8mm	4	AA
1-12	RLMP-B005MRE0	M	Indicator lamp	2	AF
1-13	XOTS740P12000	M	Screw	6	AA
1-13	XCTSF50P12000	M	Optional oversized screw	6	AA
1-14	PSEL-B001MRE0	M	Gasket, dark gray	1	AN
1-15	FUNTKB436MRK0	M	Glass key unit [KB3425LS] [KB3425LK] [KB4425LS] [KB4425LK]	1	BP
1-15	FUNTKB443MRK0	M	Glass key unit [KB3425LW] [KB4425LW]	1	BP
1-16	HDECQB001MRRO	M	Glass key deco [KB3425LS] [KB4425LS]	1	AK
1-16	HDECQB056MRRO	M	Glass key deco [KB3425LK] [KB4425LK]	1	AK
1-16	HDECQB057MRRO	M	Glass key deco [KB3425LW] [KB4425LW]	1	AK
1-17	LRTNPB003MRF0	M	Retainer [KB3425LS] [KB3425LK] [KB4425LS] [KB4425LK]	4	AD
1-17	LRTNPB002MRF0	M	Retainer [KB3425LW] [KB4425LW]	4	AD
1-18	FKNBKB010MRK0	M	Control knob assy [KB3425LS] [KB4425LS]	4	AL
1-18	FKNBKB009MRK0	M	Control knob assy [KB3425LK] [KB4425LK]	4	AG
1-18	FKNBKB006MRK0	M	Control knob assy [KB3425LW] [KB4425LW]	4	AD
1-19	GWAKPB219MRF0	M	C/P frame [KB3425LS] [KB3425LK]	1	BA
1-19	GWAKPB220MRF0	M	C/P frame [KB3425LW]	1	BB
1-19	GWAKPB221MRF0	M	C/P frame [KB4425LS] [KB4425LK]	1	BB
1-19	GWAKPB222MRF0	M	C/P frame [KB4425LW]	1	BC

# CONTROL PANEL



# CONTROL PANEL HARNESS



Actual wire harness may be different from illustration.

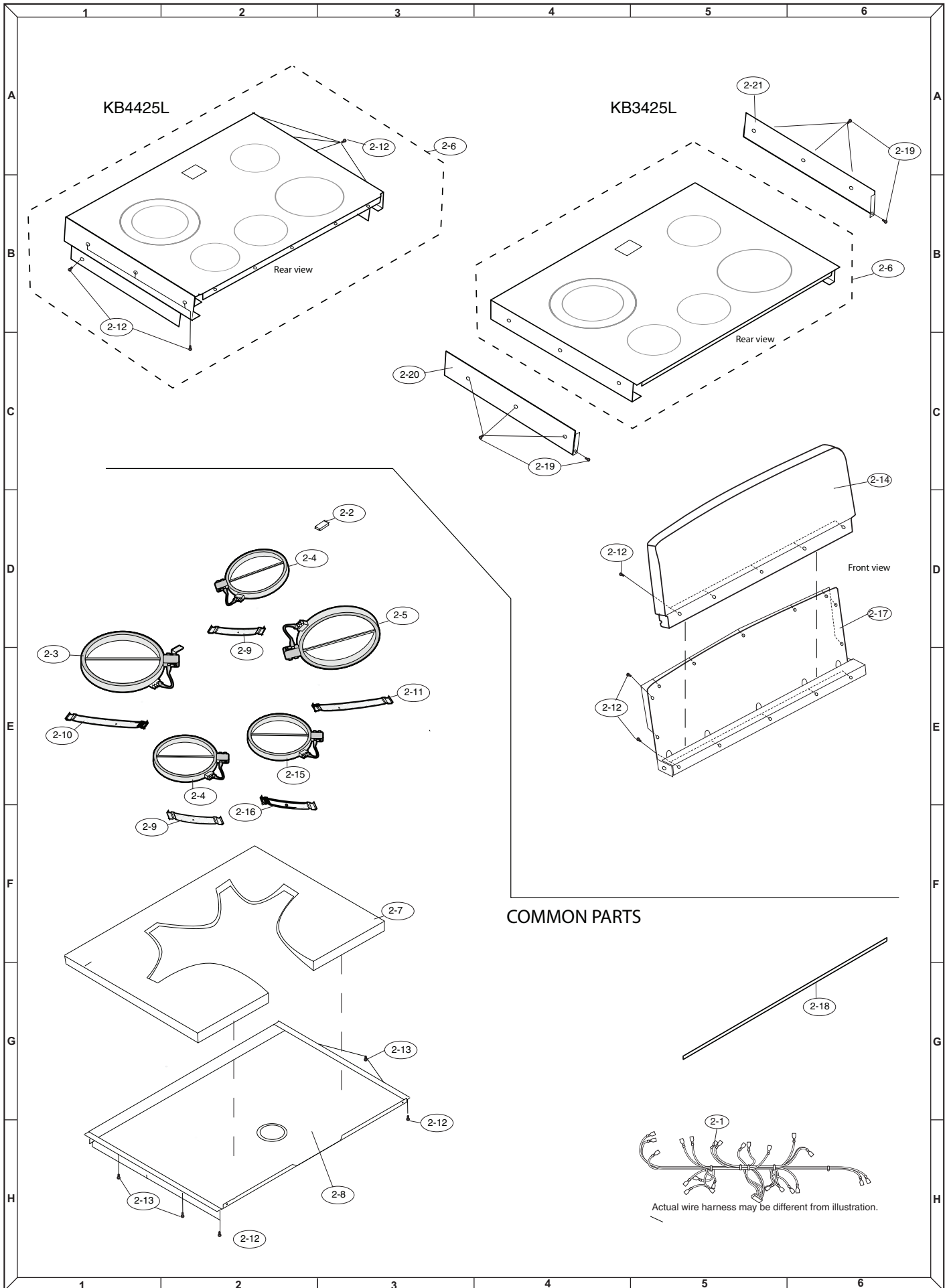


## COOK TOP PARTS LIST

**Note: The parts marked "Δ" may cause undue microwave exposure.  
The parts marked "\*" are used in voltage more than 250V.**

**"§" MARK: PARTS DELIVERY SECTION**

REF. NO.	PART NO.	§	DESCRIPTION	Q'TY	CODE
2- 1	FW-VZB303MRE0	M	Cook top harness	1	AY
2- 2	RLMP-B001MRE0	M	Surface indicator	1	AU
2- 3	RHET-B001MRE0	M	Radiant heater (2000 w)	1	BA
2- 4	RHET-B002MRE0	M	Radiant heater (1200 w)	2	AZ
2- 5	RHET-B003MRE0	M	Radiant heater (Dual)	1	BD
2- 6	FANG-B027MRY0	M	Cook top glass assy [KB3425LS] [KB3425LK]	1	CA
2- 6	FANG-B028MRY0	M	Cook top glass assy [KB3425LW]	1	CA
2- 6	FANG-B030MRY0	M	Cook top glass assy [KB4425LS] [KB4425LK]	1	CC
2- 6	FANG-B031MRY0	M	Cook top glass assy [KB4425LW]	1	CC
2- 7	PFPF-B009MRE0	M	Heat protect	1	AH
2- 8	PCOVPB158MRP0	M	Heat protect cover	1	AP
2- 9	MLEVPB018MRE0	M	6" spring strap	2	AH
2-10	MLEVPB020MRE0	M	8" spring strap	1	AH
2-11	MLEVPB021MRE0	M	9" spring strap	1	AH
2-12	XOTS740P12000	M	Screw	25	AA
2-13	LX-CZB027MRE0	M	Shoulder screw	4	AA
2-14	HDEC-B038MRY0	M	Backsplash [KB3425LS]	1	BV
2-14	HDEC-B034MRT0	M	Backsplash [KB3425LK]	1	BS
2-14	HDEC-B035MRT0	M	Backsplash [KB3425LW]	1	BS
2-15	RHET-B012MRE0	M	Radiant heater warm	1	BB
2-16	MLEVPB019MRE0	M	7" spring strap	1	AK
2-17	LANG-B040MRT0	M	Backsplash support	1	AV
2-18	PCUSGB075MRP0	M	Glass cushion	1	AK
2-19	LX-CZA084WRE0	M	Screw	8	AA
2-20	HDECAB353MRT0	M	Cook top deco L [KB3425LS] [KB3425LK]	1	AQ
2-20	HDECAB355MRT0	M	Cook top deco L [KB3425LW]	1	AQ
2-21	HDECAB352MRT0	M	Cook top deco R [KB3425LS] [KB3425LK]	1	AQ
2-21	HDECAB354MRT0	M	Cook top deco R [KB3425LW]	1	AQ



COMMON PARTS

Actual wire harness may be different from illustration.

## MICROWAVE DRAWER PARTS LIST

Note: The parts marked "Δ" may cause undue microwave exposure.

The parts marked "\*" are used in voltage more than 250V.

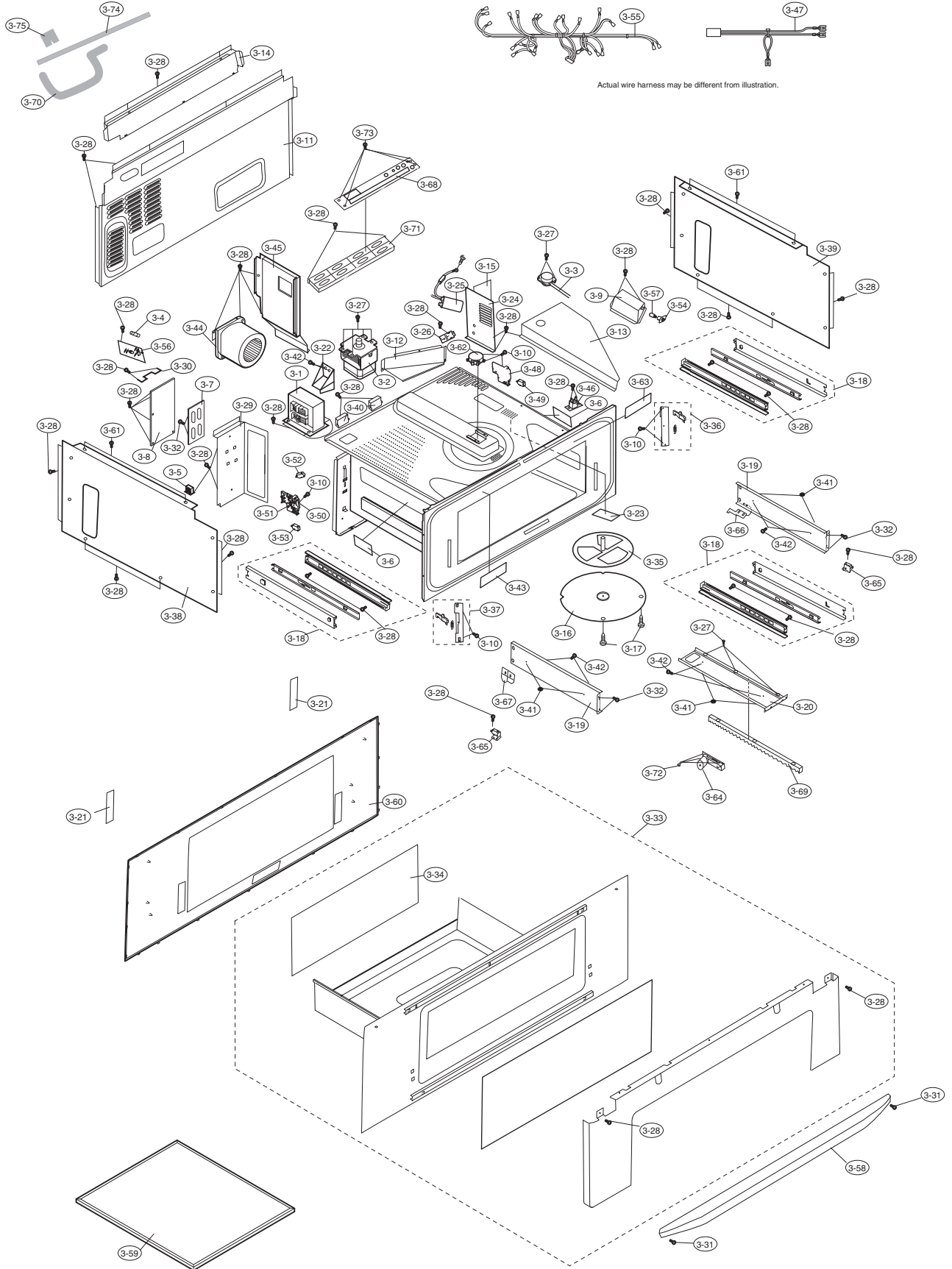
"§" MARK: PARTS DELIVERY SECTION

REF. NO.	PART NO.	§	DESCRIPTION	Q'TY	CODE
Δ 3- 1	RTRN-B083MRE0	M	Transformer	1	BE
3- 2	RV-MZA288WRE0	M	Magnetron	1	BK
3- 3	FDTCTA234WRKZ	M	Sensor assy	1	AP
3- 4	FFS-BA018/KIT	M	Monitor switch (V-16G-2C25) with fuse (20A) assembly	1	AF
3- 5	RTRNPA006WRZZ	M	Touch control transformer	1	AP
3- 6	TCAUAB050MRR0	M	Monitor caution label	2	AD
3- 7	LHLD-B028MRFOA	M	Power supply unit holder	1	AH
3- 8	DPWFB133MRU0	M	Power supply	2	BD
3- 9	LANGTB122MRP0	M	Oven lamp angle	1	AF
3-10	LX-CZ0052WRE0	M	Screw/washer	6	AA
3-11	GCABDB001MRP0	M	Back plate	1	BB
3-12	PDUC-B141MRP0	M	Mag duct	1	AE
3-13	PDUC-B142MRP0	M	Sensor duct	1	AK
3-14	PDUC-B147MRP0	M	Exhaust duct A	1	AK
3-15	PDUC-B148MRP0	M	Exhaust duct B	1	AF
3-16	FCOVPB002MRY0	M	Stir cover assy	1	AM
3-17	PCLICB003MRE0	M	Canoe clip	3	AB
3-18	MSLIFB001/KIT	M	Slide rail	3	AU
3-19	LANGTB120MRT0	M	Door support angle A	2	AK
3-20	LANGTB187MRP0	M	Door support angle B	1	AN
3-21	GCOVHB051MRF0	M	Door support cover	2	AB
3-22	PSKR-B018MRP0	M	Magnetron air guide	1	AC
3-23	PFILWB005MRP0	M	Lamp filter	1	AB
3-24	LANGTB076MRP0	M	Partition angle	1	AK
* 3-25	FC-QZB048MRK0	M	HVC assy	1	AP
3-26	LBNDKB007MRP0	M	HVC band	1	AB
3-27	LX-BZA041WRE0	M	Screw	20	AA
3-28	XOTS740P12000	M	Screw	179	AA
3-29	LANGTB156MRP0	M	Partition angle L	1	AK
3-30	LANGQA581WRPZ	M	Noise unit angle	1	AD
3-31	XJTS740P16000	M	Screw	4	AA
3-32	XOTS40P12RV0	M	Power unit assy screw	4	AA
3-33	DDORFB099MRK0	M	Door assy [KB3425LS] [KB4425LS]	1	BR
3-33	DDORFB100MRK0	M	Door assy [KB3425LK] [KB4425LK]	1	BR
3-33	DDORFB104MRK0	M	Door assy [KB3425LW] [KB4425LW]	1	BR
3-34	PSHEPB184MRE0	M	Sealer film	1	AQ
3-35	FFAN-B008MRK0	M	Stirrer fan assy	1	AK
3-36	FANGTB010MRK0	M	Latch angle assy R	1	AH
3-37	FANGTB011MRK0	M	Latch angle assy L	1	AH
3-38	LANGTB088MRP0	M	Cooktop stay L	1	AM
3-39	LANGTB094MRP0	M	Cooktop stay R	1	AY
3-40	RRLYDA012DRZZ	M	Heater relay A	2	AH
3-41	LX-NZB006MRE0	M	Cap nut	6	AA
3-42	XHTS740P08RV0	M	Screw	4	AA
3-43	TCAUKB001MRR0	M	Stirrer cover cleaning label	1	AA
3-44	FMOTEA494WRKZ	M	Fan motor	1	AZ
3-45	LANGTB155MRP0	M	Fan motor angle	1	AG
3-46	RTHM-A135WRZZ	M	Magnetron thermal cut-out	1	AD
3-47	FW-VZB310MRK0	M	Harness assy	1	BE
3-48	PHOK-A079WRF0	M	Latch hook R	1	AH
3-49	QSW-MA085WRE0	M	Switch	1	AE
3-50	PHOK-A080WRF0	M	Latch hook L	1	AF
3-51	MLEVPA214WRF0	M	Switch lever L	1	AK
3-52	QSW-MA---WRE0	M	Monitor switch - must replace by assy. (3-4)	1	AE
3-53	QSW-MA085WRE0	M	Switch	4	AE
3-54	QSOCB010MRE0	M	Lamp socket	1	AG
3-55	FW-VZB263MRE0	M	CPU harness	1	AV
3-56	FPWBFA380WRKZ	M	Noise filter unit	1	AM
3-57	RLMPTA093WRZZ	M	Oven lamp	1	AF

REF. NO.	PART NO.	§	DESCRIPTION	Q'TY	CODE
3-58	JHNDPB052MRM0	M	Door handle [KB3425LS] [KB4425LS]	1	AS
3-58	JHNDPB054MRM0	M	Door handle [KB3425LK] [KB4425LK]	1	AS
3-58	JHNDPB055MRM0	M	Door handle [KB3425LW] [KB4425LW]	1	AS
3-59	FGLSPB002MRY0	M	Oven tray assy	1	BK
3-60	GCOVHB053MRF0	M	Choke cover	1	AM
3-61	LX-CZB027MRE0	M	Shoulder screw	6	AA
3-62	RMOTDA262WRZZ	M	Stirrer motor	1	AH
3-63	TCAUHB009MRR0	M	User caution label	1	AA
3-64	FANGTB017MRK0	M	Auto drawer gear assy	1	BK
3-65	LANGTB105MRP0	M	Switch angle	2	AE
3-66	MACT-B001MRF0	M	Actuator R	1	AD
3-67	MACT-B002MRF0	M	Actuator L	1	AD
3-68	DPWBFC526WRKZ	M	SW power supply	1	CM
3-69	NGERRB005MRF0	M	Rack gear	2	AQ
3-70	PCUSUB088MRP0	M	Cushion	1	AC
3-71	LHLD-B033MRF0	M	Switch PSU holder	1	AE
3-72	XOTS740P08000	M	Screw	1	AA
3-73	XEPS730P10XS0	M	Screw	4	AA
3-74	PCUSUB084MRP0	M	Cushion	1	AG
3-75	PCUSUB086MRP0	M	Cushion	1	AA

# MICROWAVE DRAWER

# MICROWAVE DRAWER HARNESSES



## OVEN PARTS LIST

**Note: The parts marked "Δ" may cause undue microwave exposure.  
The parts marked "\*" are used in voltage more than 250V.**

**"S" MARK: PARTS DELIVERY SECTION**

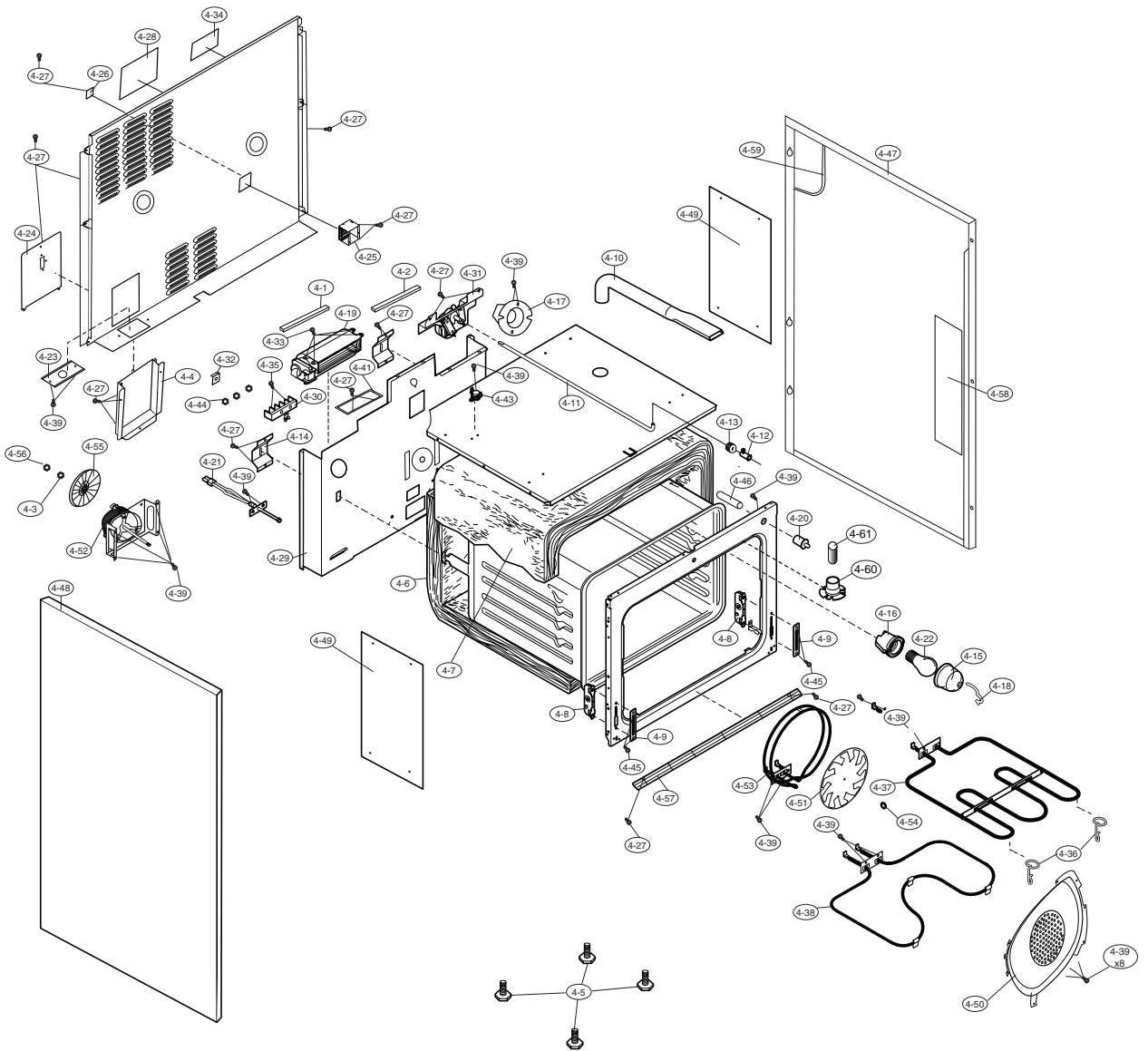
REF. NO.	PART NO.	§	DESCRIPTION	Q'TY	CODE
4- 1	PCUSGB050MRP0	M	Thermal cushion	1	AG
4- 2	PCUSGB051MRP0	M	Cross flow motor cushion	1	AG
4- 3	XWHSD80-16180	M	Washers	2	AB
4- 4	PCOVPB136MRP0	M	Heat cover	1	BD
4- 5	GLEGPB006MRE0	M	Leveling screw	4	AE
4- 6	PFPF-B012MRE0	M	Heat protect R	1	AW
4- 7	PFPF-B009MRE0	M	Heat protect Top	1	AW
4- 8	FHNG-B052MRE0	M	Receptacle hinge	2	AK
4- 9	PCOVPB131MRE0	M	Hinge cover	2	AD
4-10	PPIPFB001MRE0	M	Vent tube	1	AR
4-11	MROD-B008MRE0	M	Latch rod	1	AM
4-12	LBSHZB001MRE0	M	Bushing	1	AG
4-13	MSPRTB024MRE0	M	Bushing spring	1	AA
4-14	LANGTB079MRP0	M	Oven spring	2	AE
4-15	PCOVPB127MRE0	M	Oven light cover	1	AK
4-16	QSOCLB012MRE0	M	Oven light housing	1	AE
4-17	LANG-B018MRE0	M	Oven light receptacle	1	AH
4-18	LBNDKB011MRE0	M	Light cover retainer	1	AB
4-19	FMOTEB051MRE0	M	Blower motor	1	BF
4-20	QSW-PB002MRE0	M	Light switch	1	AF
4-21	FH-HZB001MRE0	M	Thermister	1	AT
4-22	RLMPTB001MRE0	M	Oven lamp	1	AS
4-23	LANGQB065MRP0	M	Power cord angle	1	AE
4-24	PCOVPB130MRP0	M	Power cover	1	AG
4-25	FSW-MB040MRK0	M	Select switch assy	1	AS
4-26	LANGKA760WRP0	M	Switch lever	1	AG
4-27	XOTS740P12000	M	Screw	37	AA
4-28	TCAUAB073MRR0	M	DHHS caution label	1	AB
4-29	GCABDB009MRP0	M	Rear plate	1	BE
4-30	QCNCYB001MRE0	M	Terminal block kit	1	AK
4-31	FANG-B003MRE0	M	Latch motor assy	1	AZ
4-32	LANGQB066MRP0	M	Ground plate	1	AD
4-33	LX-BZA041WRE0	M	Screw	20	AA
4-34	TCAUAB057MRR0	M	Anti-tip label	1	AA
4-35	XTTSD40P30000	M	Terminal screws	2	AA
4-36	LBNDKB012MRP0	M	Element support hanger	2	AD
4-37	RHET-B006MRE0	M	Top heater (3000 W)	1	AX
4-38	RHET-B009MRE0	M	Bottom heater (2600 W)	1	AW
4-39	XOTWW40P10000	M	Screw	8	AA
4-40	FW-VZB273MRE0	M	Power supply harness	1	BB
4-41	LANGTB092MRP0	M	Motor blower angle	1	AH
4-42	DW-VZB193MRK0	M	Harness assy	1	BE
4-43	QFS-TA038WRE0	M	Oven thermo	1	AK
4-44	LX-NZB007MRE0	M	Terminal block nut	6	AA
4-45	LX-CZB038MRE0	M	Door hinge screw	4	AA
4-46	PCOVWB001MRE0	M	Insulation tube	1	AC
4-47	GCABUB135MRP0A	M	Side cabinet R [KB3425LS] [KB3425LK] [KB4425LS] [KB4425LK]	1	BC
4-47	GCABUB138MRP0A	M	Side cabinet R [KB3425LW] [KB4425LW]	1	BC
4-48	GCABUB136MRP0A	M	Side cabinet L [KB3425LS] [KB3425LK] [KB4425LS] [KB4425LK]	1	BC
4-48	GCABUB139MRP0A	M	Side cabinet L [KB3425LW] [KB4425LW]	1	BC
4-49	PREFHB008MRP0	M	Heat reflector	2	AL
4-50	PDUC-B143MRH0	M	Convection duct	1	AY
4-51	FFAN-B017MRY0	M	Convection fan assy	1	AX
4-52	RMOTEB036MRE0	M	Convection motor	1	BB
4-53	RHET-B005MRE0	M	Convection heater	1	AX
4-54	LX-NZB009MRE0	M	Convection fan assy nut	1	AA
4-55	NFANPB007MRE0	M	Impeller blade	1	AC
4-56	LX-RZB001MRE0	M	"E" retaining clip	1	AB
4-57	PCOVPB145MRF0	M	Front cover	1	AM
4-58	PFPF-B014MRP0	M	Insulation	1	AG
4-59	PCUSUB087MRP0	M	Cushion	1	AE
4-60	PPIPFB003MRE0	M	Vent tube adapter	1	AR
4-61	PFIL-B012MRE0	M	Catalyst	1	AW

# OVEN UNIT

## OVEN UNIT HARNESSSES



Actual wire harness may be different from illustration.



## OVEN DOOR PARTS LIST

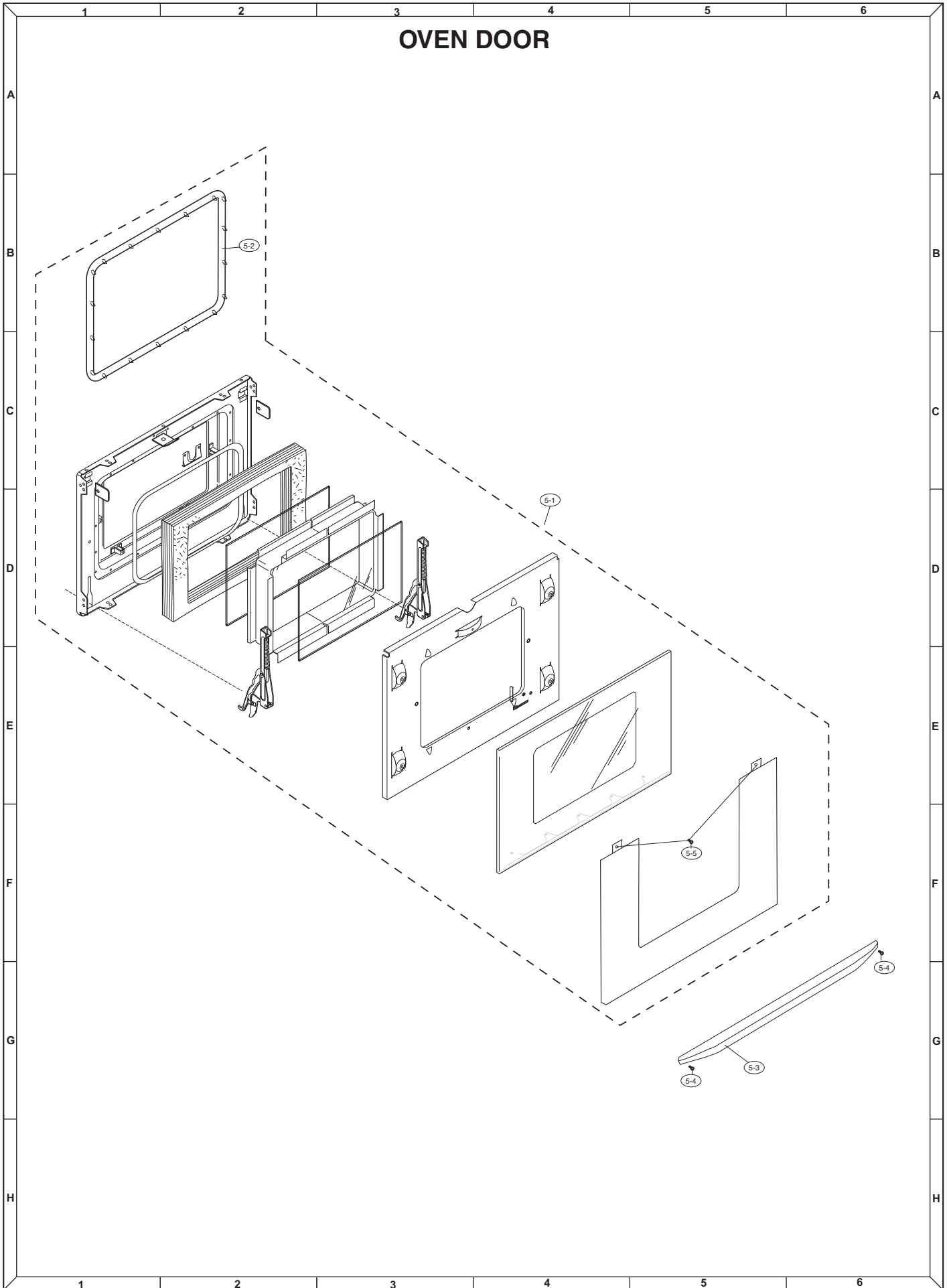
**Note: The parts marked "Δ" may cause undue microwave exposure.  
The parts marked "\*" are used in voltage more than 250V.**

**"§" MARK: PARTS DELIVERY SECTION**

REF. NO.	PART NO.	§	DESCRIPTION	Q'TY	CODE
5- 1	DDORFB107MRK0	M	Door assy [KB3425LS] [KB4425LS]	1	BY
5- 1	DDORFB106MRK0	M	Door assy [KB3425LK] [KB4425LK]	1	BY
5- 1	DDORFB105MRK0	M	Door assy [KB3425LW] [KB4425LW]	1	BY
5- 2	PPACGB021MRE0	M	Oven door seal gasket	1	AW
5- 3	JHNDPB053MRF0	M	Door handle [KB3425LS] [KB4425LS]	1	BB
5- 3	JHNDPB056MRF0	M	Door handle [KB3425LK] [KB4425LK]	1	BB
5- 3	JHNDPB057MRF0	M	Door handle [KB3425LW] [KB4425LW]	1	BB
5- 4	XOTWW40P10000	M	Screw	2	AA
5- 5	XOTS740P12000	M	Screw	2	AA



# OVEN DOOR



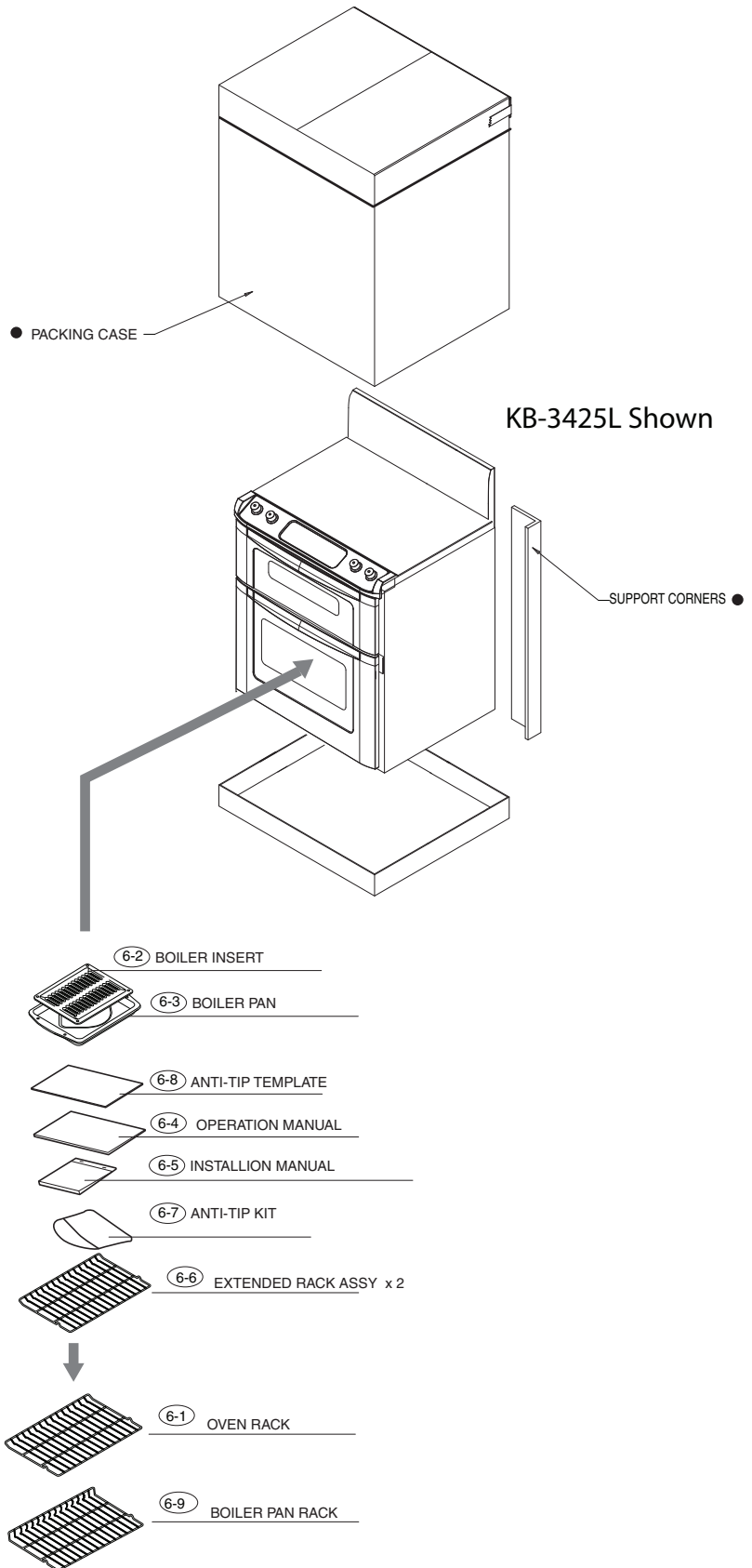
## PACKING PARTS LIST

**Note: The parts marked "Δ" may cause undue microwave exposure.  
The parts marked "\*" are used in voltage more than 250V.**

**"§" MARK: PARTS DELIVERY SECTION**

REF. NO.	PART NO.	§	DESCRIPTION	Q'TY	CODE
6- 1	UAMI-B018MRM0	M	Rack	1	AS
6- 2	PSLD-B001MRE0	M	Broiler pan insert	1	AW
6- 3	PSRAHB001MRE0	M	Broiler pan	1	AW
6- 4	TINSEB437MRK0	M	Operation manual	1	AM
6- 5	TINSEB438MRR0	M	Installation sheet [KB3425L]	1	AD
6- 5	TINSEB455MRR0	M	Installation sheet [KB4425L]	1	AE
6- 6	FAMI-B007MRK0	M	Extended rack assy	2	BM
6- 7	FANGKB024MRK0A	M	Anti-tip kit	1	AV
6- 8	TINSEB392MRR0	M	Anti-tip template	1	AD
6- 9	UAMI-B017MRM0	M	Broiler pan rack	1	AR

# PACKING



● Non-replaceable items

# SHARP

COPYRIGHT © 2006 BY SHARP CORPORATION

ALL RIGHTS RESERVED.

No part of this publication may be reproduced, stored in retrieval systems, or transmitted in any form or by any means, electronic, mechanical, photocopying, recording, or otherwise, without prior written permission of the publisher.