



TRAEGER®

WOOD PELLET GRILLS











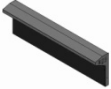



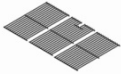

Assembly Instructions BBQ400.04



DOC136 REV B

PARTS LIST

PART PREVIEW	DESCRIPTION	QTY	PART#	ID#
	1/4-20 SHOULDER BOLT LONG	4	HDW154	A
	WASHER 1/2OD X 1/4 ID FLAT ZINC	38	HDW249	B
	TOP SECTION	1		C
	1/4-20 x .625 PHILLIPS PAN HEAD Zinc	16	HDW066	D
	1/4 Lock Washer Zinc	16	HDW113	E
	1/4-20 x .500 Truss Head Screw Zinc	16	HDW095	F
	8-32 x .500 PPHD Zinc	4	HDW245	G
	Door Handle Gasket	2	INS147	H
	Base Pan Assembly	1	SUB264	I
	Right Panel Assembly	1	SUB267	J
	Left Panel Assembly	1	SUB265	K
	Swivel Caster	2	HDW051	L
	Fixed Caster	2	HDW052	M
	Hopper Burner Assembly	1	SUB268	N
	1/4-20 SHOULDER BOLT SHORT	2	HDW155	O
	Left Shelf Assembly	1	SUB277	P
	Right Shelf Assembly	1	SUB278	Q
	Handle	3	HDW227	R
	Door Right Door Left	1 1	SUB273 SUB280	S

	Upper Hinge Assembly	2	SUB309	T
	Front Panel Assembly	1	SUB260 BCA253	u
	Grease Drain Assembly	1	SUB254	V
	Heat Baffle	1	BCA289	W
	Drip Pan	1	BCA288	X
	Porcelain Grills	2 1	HDW093 HDW094	Y
	Washer 3/4 OD X 5/16 ID Zinc	8	HDW250	Z
	Lower Back Panel Assembly	1	SUB266	AA
	#8 X .375 Phillips Pan Head Zinc	8	HDW244	BB
	1/4-20 X .500 Truss Head SST	8	HDW095	CC
	8-32 X .375 PPHD SST	4	HDW097	DD
	1/4-20 X .375 Phillips Pan Head Zinc	6	HDW251	EE
	1/4-20 X 1.5 HEX HEAD BOLT	4	HDW156	FF
	8-32 X .187 PPHD SST	2	HDW053	GG
	#8 Lock Washer	2	HDW074	HH
	#8 Flat Washer	2	HDW032	II
	Hopper Lid Handle	1	FAB055	JJ
	Wire tie	1	HDW128	KK

Before assembly begins verify that you have all the correct parts from the above list of parts. The hardware kit shown on page 3 includes all the screws, nuts, bolts, and gaskets required for assembly. The back of the package identifies the ID# of the hardware as used in the instructions.

Tools needed for the assembly of the BBQ are:

A Phillips head screw driver, Flat head screw driver, and a 7/16 socket or nut driver or wrench.

Two people will be required to assemble the BBQ.

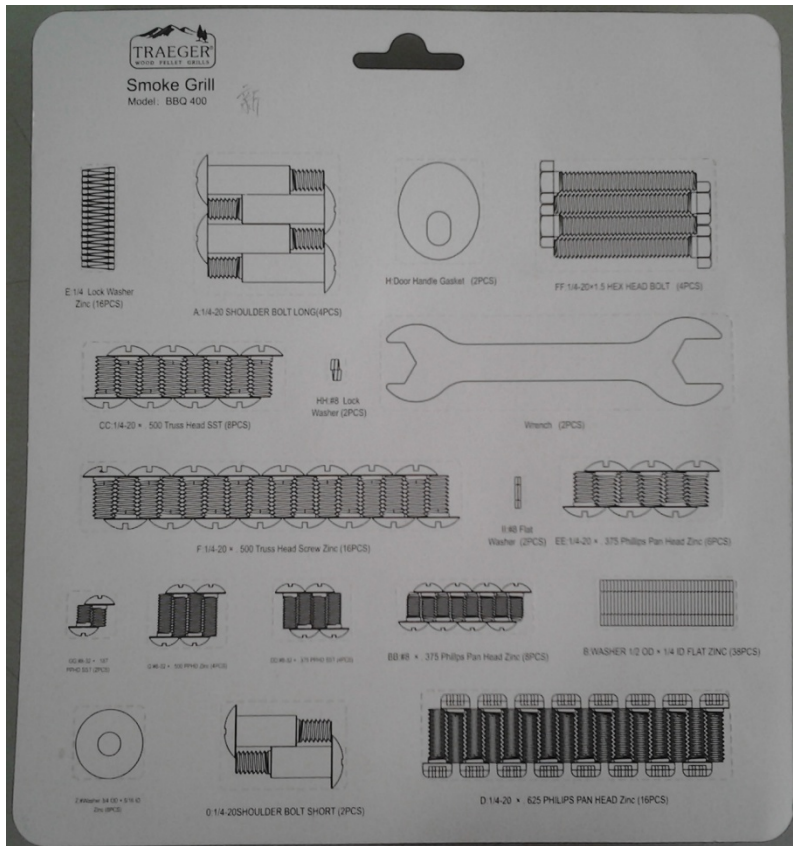

HARDWARE KIT BACK



HARDWARE KIT FRONT

1. Install fixed casters (M) onto the base stiffener located to the right of the base pan assembly (I). Secure using 4 each Phillips head bolt (D), lock washer (E) and washer (B) per caster. Install swivel casters (L) onto base stiffener located to the left of the base pan assembly. Secure using 4 each Phillips head bolts (D), lock washer (E), and washer (B) per caster. Install magnets by pushing into rectangular cutouts provided.

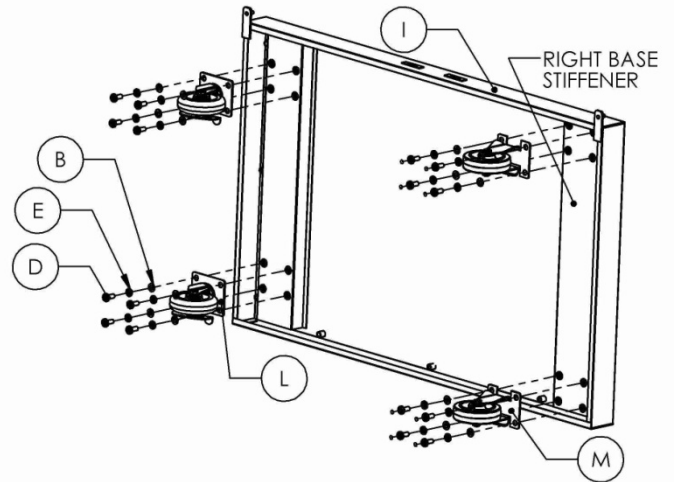

2. Insert left panel assembly (K) onto base pan assembly flush to the front and flush to the side. Insert the screws (F) and washers (B) into holes provided and secure loosely.

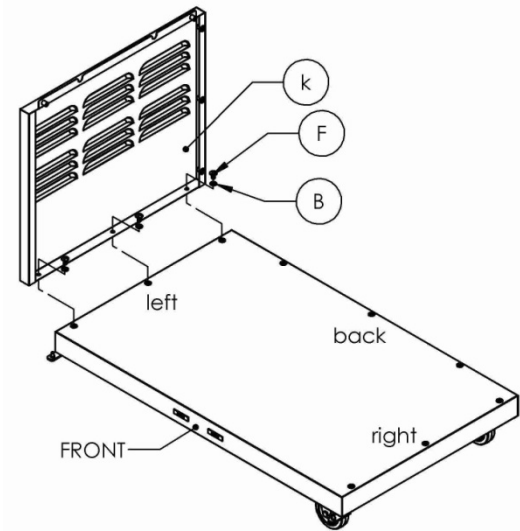

3. Insert right panel assembly (J) onto base pan assembly flush to the front and flush to the side. Insert the screws (F) and washers (B) into holes provided and secure loosely.

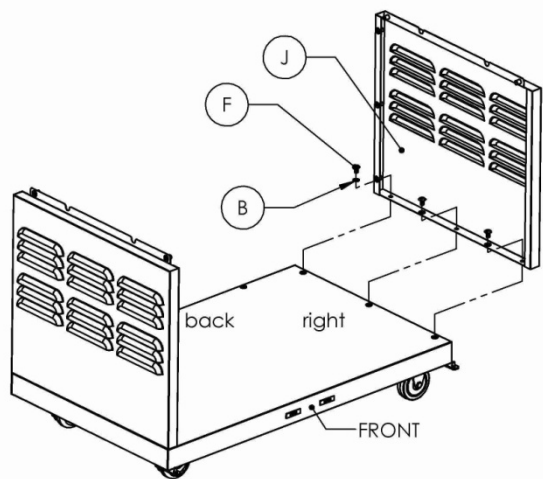

4. Insert lower back panel assembly (AA) onto base pan assembly flush to the bottom and flush to the back. Insert the 3 screws (F) and washers (B) into the bottom holes and secure loosely. Insert the 6 screws (B) and washers (F) into the holes located on the inside of the back panel flange and secure loosely.

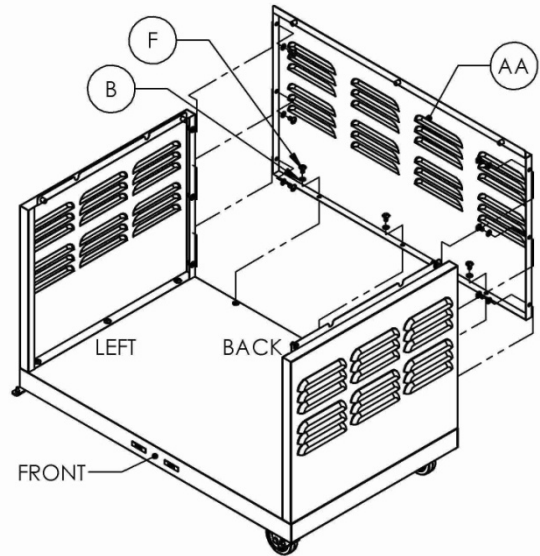

5. Insert top section (C) of BBQ400 onto the base section completed through steps 1-4. Insert 2 each shoulder bolts long (A) into holes provided on right side and secure to base cabinet. Insert 2 each shoulder bolts long (A) into holes provided on left side and secure to the base cabinet.

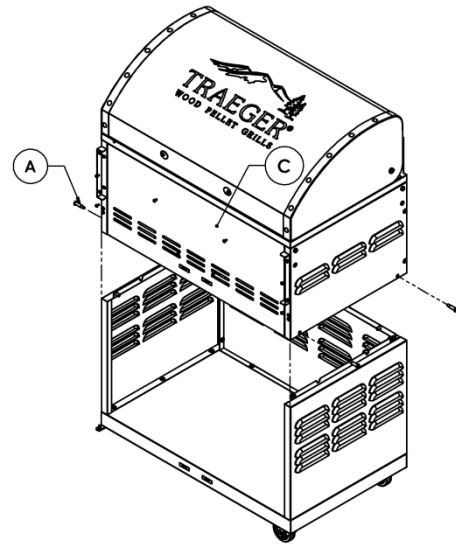

6. Insert 2 each shoulder bolts short (o) into holes provided at the bottom of the back panel. Secure to the base cabinet. At this time secure all screws from section 4 on the inside securely.

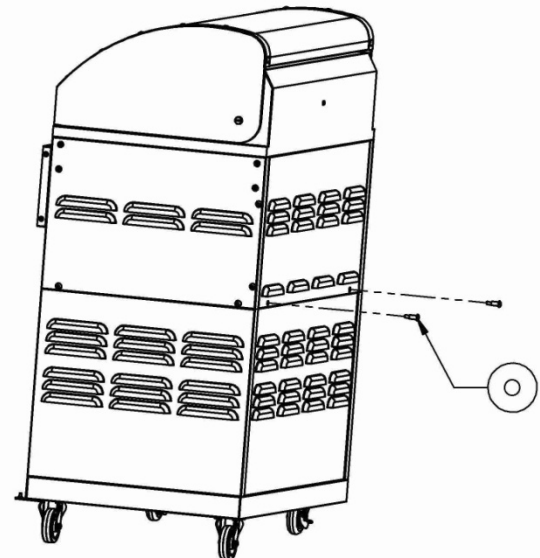

- Before hopper installation ensure that the connector for the temperature probe is inserted into hole located on the right side of the hopper mounting face. Insert hopper burner assembly (N) onto BBQ on left side flush to the upper side panel. From inside of firebox insert 4 each bolt (FF) and washers (Z) into holes provided and secure to hopper assembly. Secure hopper to support using screw (F) and washer (B) through support and into the end of the hopper assembly. Plug in the temperature probe to the mating connector from the digital temperature controller. Wire tie (KK) the wires to the digital probe out of the way as to not interfere with any of the fans in the hopper area.

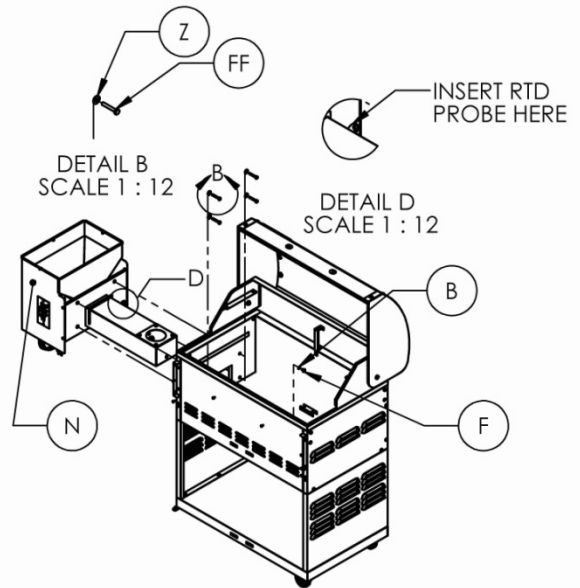

- Install hopper lid handle (JJ) onto left shelf assembly using holes for alignment. Insert lock washer (HH) and washer (II) onto screw (GG) and insert from inside the hopper lid into the handle and secure. Do not over tighten. Repeat process on other side.

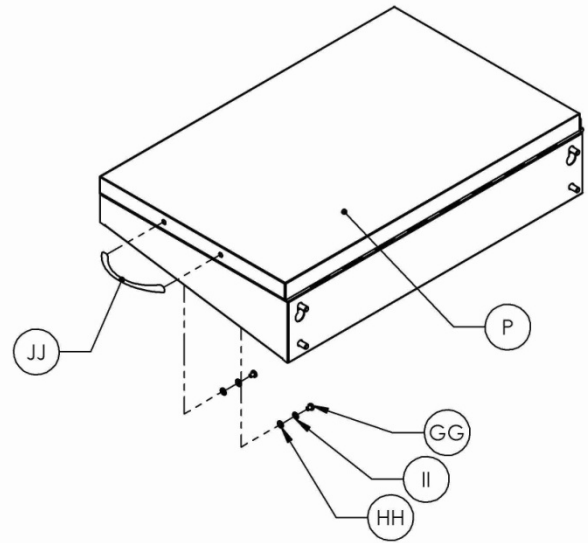

- Install the top back and front screws (CC) and leave loose. Install left shelf assembly (P) onto the BBQ left side by inserting over the hopper top and onto the screws with the keyhole slot to hold in place. Secure using 2 screws (CC) and 2 washers (Z) from the underneath side of the shelf in 2 places. Flush the shelf front to back and tighten all 4 screws.

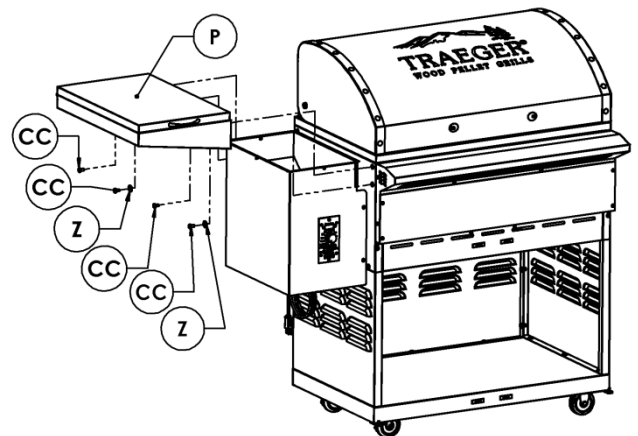

10. Insert 3 each screws (BB) into holes provided on the inside of the shelf flange. Secure into the hopper top flange to secure hopper to the shelf. Loosen the screws for the shelf to adjust for alignment if needed.

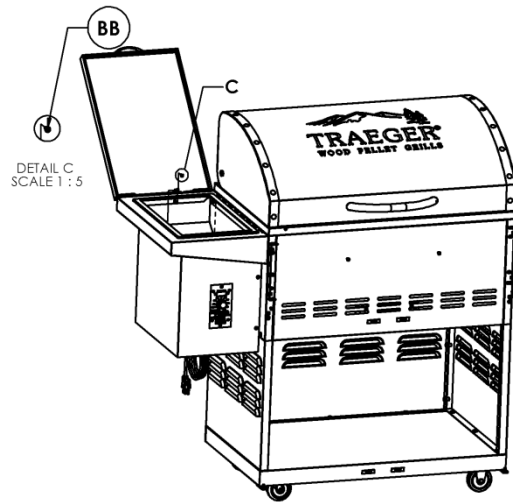

11. Install the top back and front screws (CC) and leave loose. Then Insert right shelf assembly (Q) onto the screws using the keyhole slot to hold in place. Install 2 each screws (CC) and washers (Z) from the underneath side of the shelf. Center shelf so it is flush front and back and secure to cabinet side.

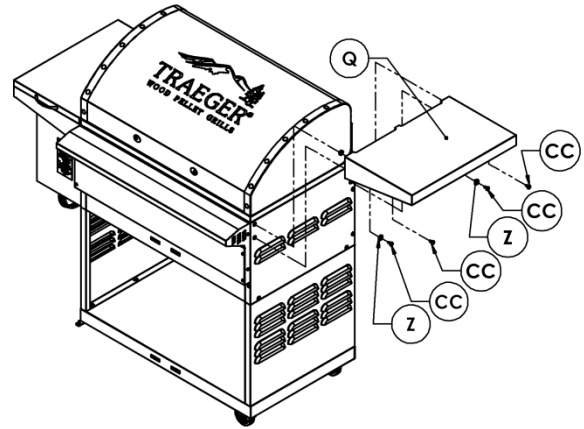

12. Insert handle (R) onto door (S) aligning with holes provided. Insert washer (B), onto screw (EE) and insert into the back panel of the door into the door handle and secure. Repeat the process in the top hole of the handle. Repeat process on the other door.

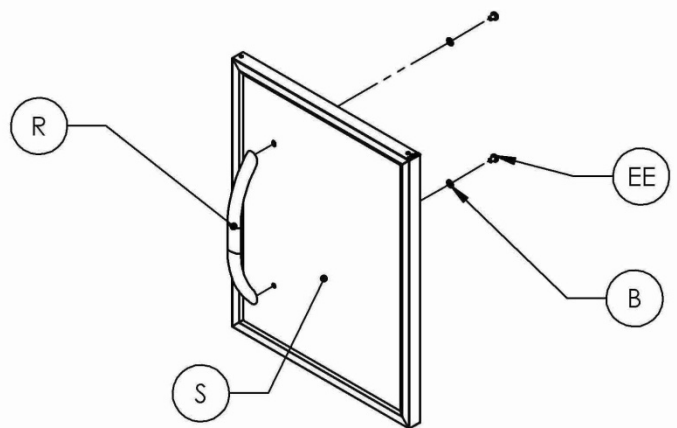

13. Insert upper door hinge (T) into hole provided on door left. Insert the door onto the lower pin located on the base pan. Insert screw (G) into hinge bracket and secure to the cabinet. Repeat the process on the right door. Adjust so the doors are even and open without interference.

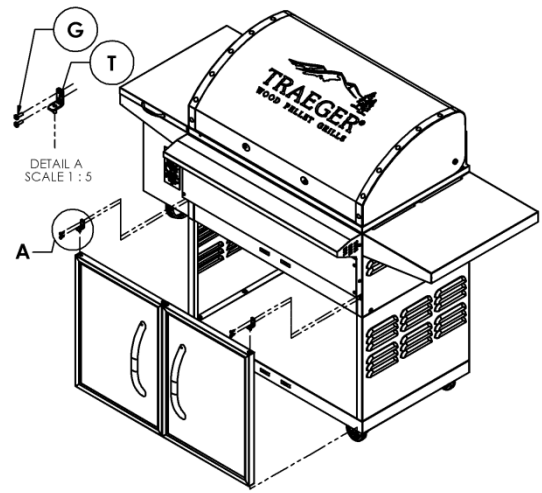

14. Insert gasket (H) onto handle (R) so it aligns. Insert handle with gasket onto BBQ lid and align with holes provided. Insert washer (B) onto screw (EE) and install from the inside of the lid. Secure into handle do not over tighten. Repeat the process on the other hole for the handle.

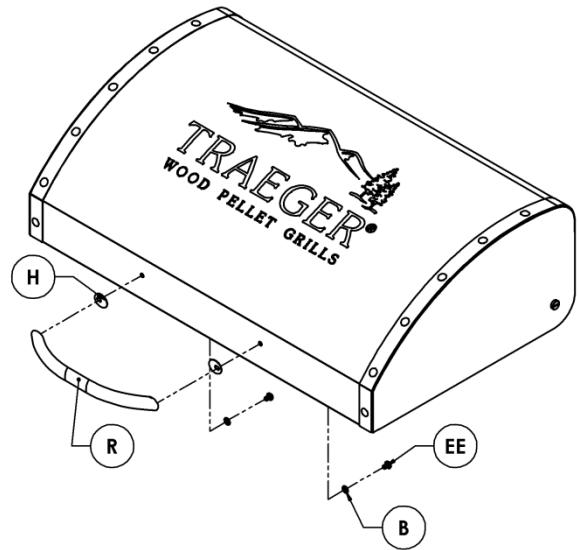

15. Insert front trim part (U) onto BBQ flush side to side and flush to the lower flange of the firebox. Insert 2 screws (DD) into the right side of the panel and secure to the trim base part. Repeat the process for the screws on the left side.

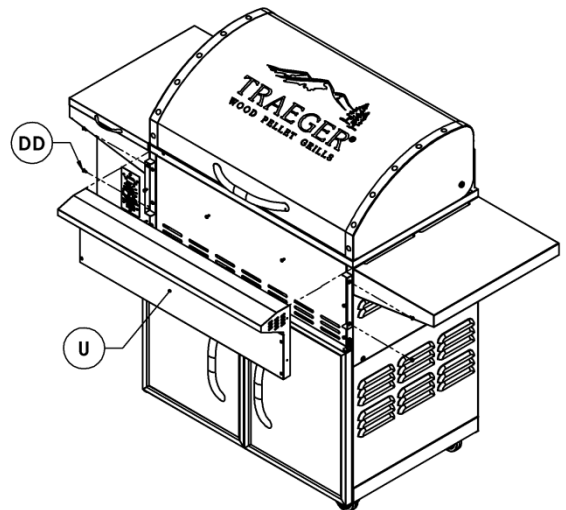

16. Insert grease drain assembly (V) into the inside of the firebox and align with holes provided. Secure using 5 screws (BB) to the right sidewall and base of the firebox.

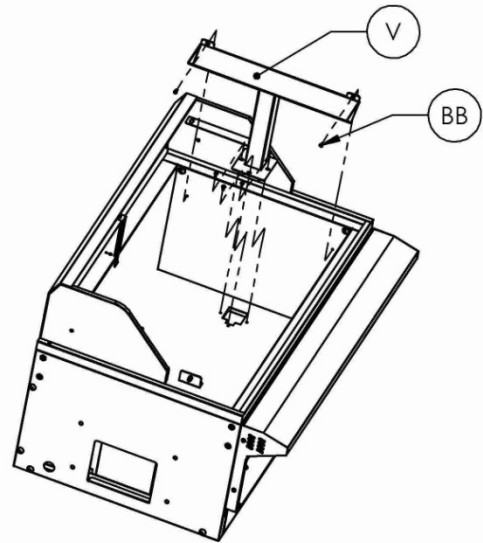

17. Insert heat baffle into the BBQ and insert into the notches in the clips located at the base of the firebox.

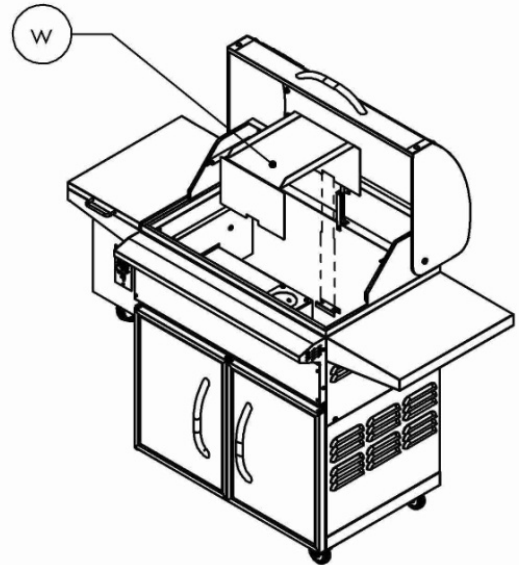

18. Install drip pan into BBQ with the small flange on the bracket on the left side of the firebox. The larger flange should go into the grease drain and center front to back.

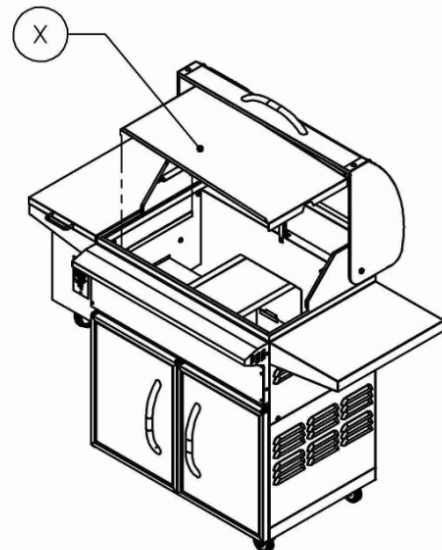

19. Install Porcelain grill (Y) onto the BBQ inserting the grills without the cutout onto the grill first. You will need to tilt the grill up on the back side and insert under flange and then down onto BBQ surface. Keep the side grills flush to the outer walls of the BBQ. Then insert the center grill onto the BBQ the same way so the cutout is centered over the probe guard. Adjust grills so that they are touching together.

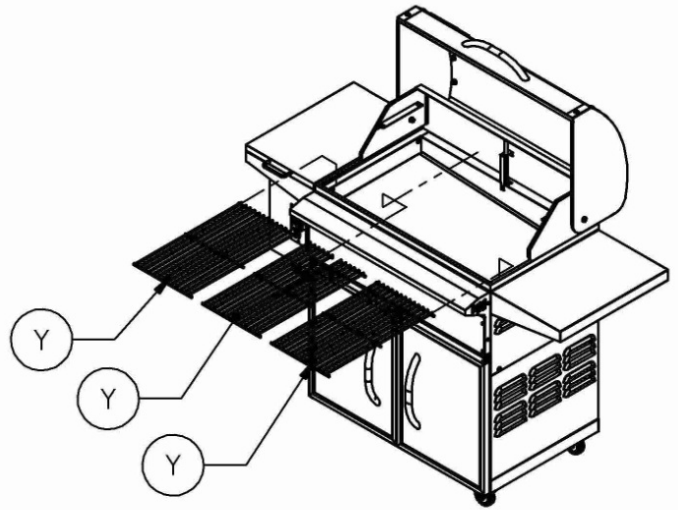

20. Insert grease bucket onto the inside of the lower cabinet and hook onto the tab located on the grease drain. Ensure that the bucket is centered over the tube.

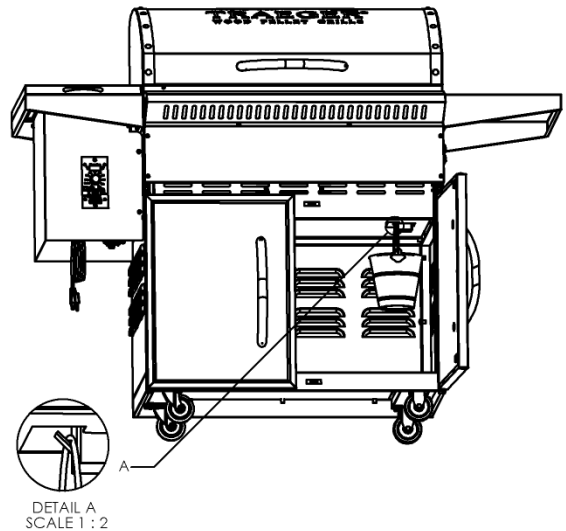

Read the instruction manual before using your Traeger BBQ400.04.

If you have any questions or problems contact Traeger Customer service. Contact information is located on the following page.

TRAEGER PELLET GRILLS, LLC
1215 Wilmington Ave Suite 200
Salt Lake City, UT 84106

TRAEGER TECHNICAL SUPPORT
Available 7 Days a Week 5AM to 7PM
Pacific Time

TRAEGER PARTS DEPARTMENT
Available Weekdays 8AM to 3:30PM
Pacific Time

TRAEGER SALES/ORDER DESK
Available Weekdays 8AM to 4:30PM
Pacific Time

TOLL-FREE TELEPHONE: 1-800-872-3437

E-mail: service@traegergrills.com
Website: www.traegergrills.com

