

This Owner's Manual is provided and hosted by [Appliance Factory Parts](#).

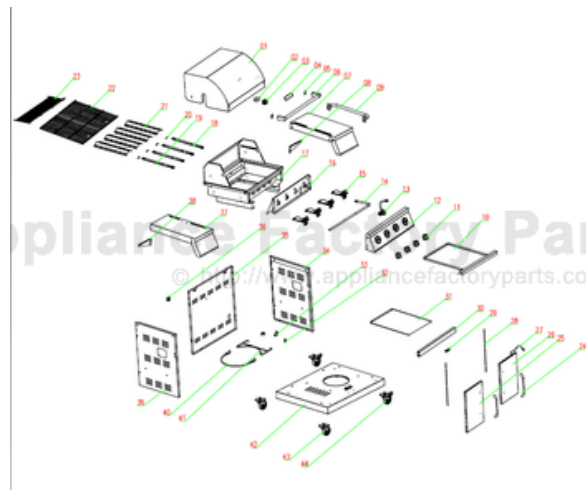

# Permasteel PG-50403SRL-1 Owner's Manual

[Shop genuine replacement parts for Permasteel  
PG-50403SRL-1](#)



[Find Your Permasteel Grill Parts - Select From 54 Models](#)

----- Manual continues below -----

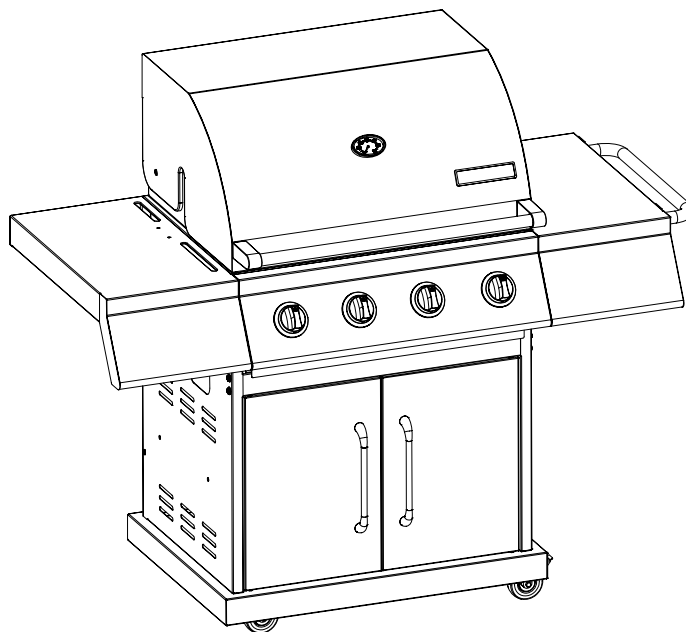

**FOR OUTDOOR USE ONLY**

**GAS BBQ GRILL USER'S MANUAL**

**MODEL NUMBER: PG-50403SRL**

**CUSTOMER SERVICE: (888)-287-0735**



**DANGER**

If you smell gas:

1. Shut off gas to the appliance.
2. Extinguish any open flame.
3. Open lid.
4. If odor continues, keep away from the appliance and immediately call your gas supplier or your fire department.



**WARNING**

1. Do not store or use gasoline or other flammable liquids or vapors in the vicinity of this or any other appliance.
2. An LP cylinder not connected for use shall not be stored in the vicinity of this or any other appliance.

# LIMITED WARRANTY

## **Model Number: PG-50403SRL PermaSteel BBQ Grill**

PERMASTEEL INC. Warranties that this Product shall be free from defects in workmanship and materials, for a period of 1 Year from the date of original purchase. Our obligation under this warranty shall be limited to replacement of parts during the warranty period. Our liability shall not extend beyond replacement of parts, This warranty excludes, normal wear & tear such as paint loss, discoloration and rust on the Product and its parts or components, and any damage arising from any of the following: negligent use or misuse of the Product, use contrary to this User's Manual, or alteration by any one other than Permasteel Inc. All warranty coverage is void if this grill is ever used for commercial or rental purposes; this warranty is valid only in the USA. The warranty period of 1 year shall not be extended or renewed by the repair or replacement of parts or compensation for the Product. If your Product is defective or otherwise requires service or parts, please call Permasteel Customer Service toll-free at (888)-287-0735, between 8:00 a.m. and 5:00 p.m. PST. Consumer is responsible for shipping, handling and processing of warranty claims after 30 days of purchase date. As proof of purchase a copy of your original purchase receipt must accompany any service request,

<u>Component</u>	<u>Warranty Period:</u>
Burners:	1 Year
Stainless Steel Flame Tamer:	1 Year
Cast Iron Cooking Grids:	1 Year
Valves:	1 Year
Frame, Housing, Cart, Control Panel, Igniter, and Related Parts:	1 Year
All Stainless Steel Parts:	1 Year

## **LIMITATION OF REMEDIES AND LIABILITY**

We shall not be liable for any incidental or consequential damages for breach of any express or implied warranty on its Product. Except to the extent prohibited by applicable law, any implied warranty or merchantability or fitness for a particular purpose on this Product shall be limited to the duration of the above warranty. Neither us nor anyone else who has been involved in the creation, production, or delivery of the Product shall be liable for damages of any type, including but not limited to any lost profits, lost savings, loss of anticipated benefits, or other incidental or consequential damages which may arise out of the purchase, use, or inability to use the Product, whether arising out of contract, negligence, strict tort, or under any warranty, or otherwise, even if you have been advised of the possibility of such damage or any other claim by any other party. Our liability for any breach of warranty shall be limited to repair or replacement of the defective part or parts as described above. Some states do not allow the exclusion or limitation of incidental or consequential damages, so the above limitation or exclusion may not apply to you. The above warranty gives you specific legal rights, and you may have other rights which vary from state to state.

# TABLE OF CONTENTS

## BEFORE YOU BEGIN

MESSAGE TO OUR USERS	-----	PAGE 1
SAFETY SYMBOLS	-----	PAGE 1
INSTALLATION & SAFETY PRECAUTIONS	-----	PAGE 2
PROPANE & GAS WARNING	-----	PAGE 2

## ASSEMBLY

PARTS	-----	PAGE 3
STEP I	-----	PAGE 5
STEP II	-----	PAGE 6
STEP III	-----	PAGE 7
STEP IV & STEP V	-----	PAGE 8
SAFETY NOTICE	-----	PAGE 9

## POST ASSEMBLY

GAS CONNECTION	-----	PAGE 10
LEAK TESTING	-----	PAGE 13
FINAL INSTALLATION CHECK LIST	-----	PAGE 14
GRILL LIGHTING INSTRUCTION	-----	PAGE 15
OPERATING INSTRUCTION	-----	PAGE 17
CARE & MAINTENANCE	-----	PAGE 19
TROUBLE SHOOTING	-----	PAGE 20
FOOD SAFETY	-----	PAGE 21
GRILL STORAGE	-----	PAGE 21

# MESSAGE TO OUR USERS

Thank you for your purchase of our Stainless Steel BBQ Gas Grill. We sincerely wish you will enjoy using our fine products.

- Please read this User's Manual in its entirety before using the grill.
- Please contact our customer service at (888)-287-0735 if you have any questions.
- Please read this User's Manual carefully. Failure to follow the provided instruction can result in seriously bodily injury and/or property damage.
- Some parts of this grill may have sharp edges. Please wear suitable protective gloves.



**IMPORTANT:** This grill is intended for outdoor use only and is not intended to be installed in or on recreational vehicles or boats.

**NOTE TO INSTALLER:** Leave this User's Manual with the customer after delivery and/or installation.

**NOTE TO CONSUMER:** Leave this User's Manual in a convenient place for future reference.

# SAFETY SYMBOLS

The symbols listed here are being used through out this User's Manual. Please pay special attention to them. The meaning of each of the symbols is listed here:

-  **DANGER**– this symbol indicates an imminently hazardous situation which will result in death or serious bodily injury if not properly followed.
-  **WARNING**– this symbol indicates a warning of potential serious bodily injury if the instructions are not strictly followed. Please be sure to read and follow all these messages carefully.
-  **CAUTION**– this symbol indicates a potentially hazardous situation which may result in minor or moderate bodily injury if the instructions are not properly followed.

# INSTALLATION/SAFETY PRECAUTIONS



## WARNING

### READ THIS SECTION FIRST BEFORE INSTALLING THE GRILL

- This grill is designed to use LP gas only. Please use the grill with the regulator supplied by PermaSteel. Please only use LP gas.
- The installation of this appliance must conform with local codes or, in the absence of local codes, with either the **National Fuel Gas Code, ANSI Z223. 1, or CAN/CGA B149.1, Natural Gas Installation Code or CAN/CGA-B149.2, Propane Installation Code.**
- The LP-gas supply cylinder is to be constructed and marked in accordance with the specifications for LP-gas cylinders of the **U.S. Department of Transportation (DOT) or the National Standard of Canada, CAN/CSA-B339, Cylinders, Spheres and Tubes for the Transportation of Dangerous Goods.**
- If an external electrical source is utilized, the outdoor cooking gas appliance, when installed, must be electrically grounded in accordance with local codes or, in the absence of local codes, with **the National Electrical Code, ANSI/NFPA 70-1990, or the Canadian Electrical Code, CSA C22.1.** Keep the power cord of the motor away from the hot surfaces of the grill while in use. Remove and store the motor in a dry place when not in use.
- This grill is safety certified for use in the United States and Canada only. Never modify to use in other places. Modification may cause serious bodily injury or property damage. PermaSteel is not responsible for any modifications, and all warranties will be void.

# PROPANE & GAS WARNING



## WARNING

### FOR YOUR SAFETY, PLEASE READ THIS SECTION FIRST

- If you smell gas:
  - Shut off gas to the appliance.
  - Extinguish any open flame.
  - Open lid.
  - If odor continues, keep away from the appliance and immediately call your gas supplier or your fire department.
- Do not store or use gasoline or other flammable liquids or vapors in the vicinity of this or any other appliance.
- Any LP cylinder not connected for use should not be stored in the vicinity of this or any other appliance.

# GRILL PARTS LIST

REF#	DESCRIPTION	Q'TY	REF#	DESCRIPTION	Q'TY
1	Lid	1	23	Warming Rack	1
2	Insulation Seat	1	24	Door Handles	2
3	Temp. Gauge	1	25	Left Door	1
4	Name Plate	1	26	Right Door	1
5	Insulation Seats	2	27	Match Holder Lighting Rod	1
6	Lid Handle	1	28	Door Hinge	2
7	Right Side Shelf	1	29	Door Magnet	2
8	Right Side Shelf Bracket	1	30	Door Bracket	1
9	Push Bar	1	31	Heat Insulate Panel	1
10	Grease Tray	1	32	Tank Holder Seats	2
11	Knob	4	33	Gas Hose Hook	1
12	Control Panel	1	34	Right Side Panel	1
13	Regulator	1	35	Back Panel	1
14	Manifold	1	36	Hole Bushing	1
15	Gas Valve	4	37	Left Side Shelf	1
16	Valve Bracket	1	38	Left Side Shelf Bracket	1
17	Firebox	1	39	Left Side Panel	1
18	Main Burners	3	40	Rubber Strap	1
19	Left Main Burner	1	41	Tank Holder	1
20	Burner Brackets	4	42	Bottom Panel	1
21	Flame Tamer	4	43	Casters without Brake	2
22	Cooking Grid	2	44	Casters with Brake	2

# GRILL PARTS DIAGRAM

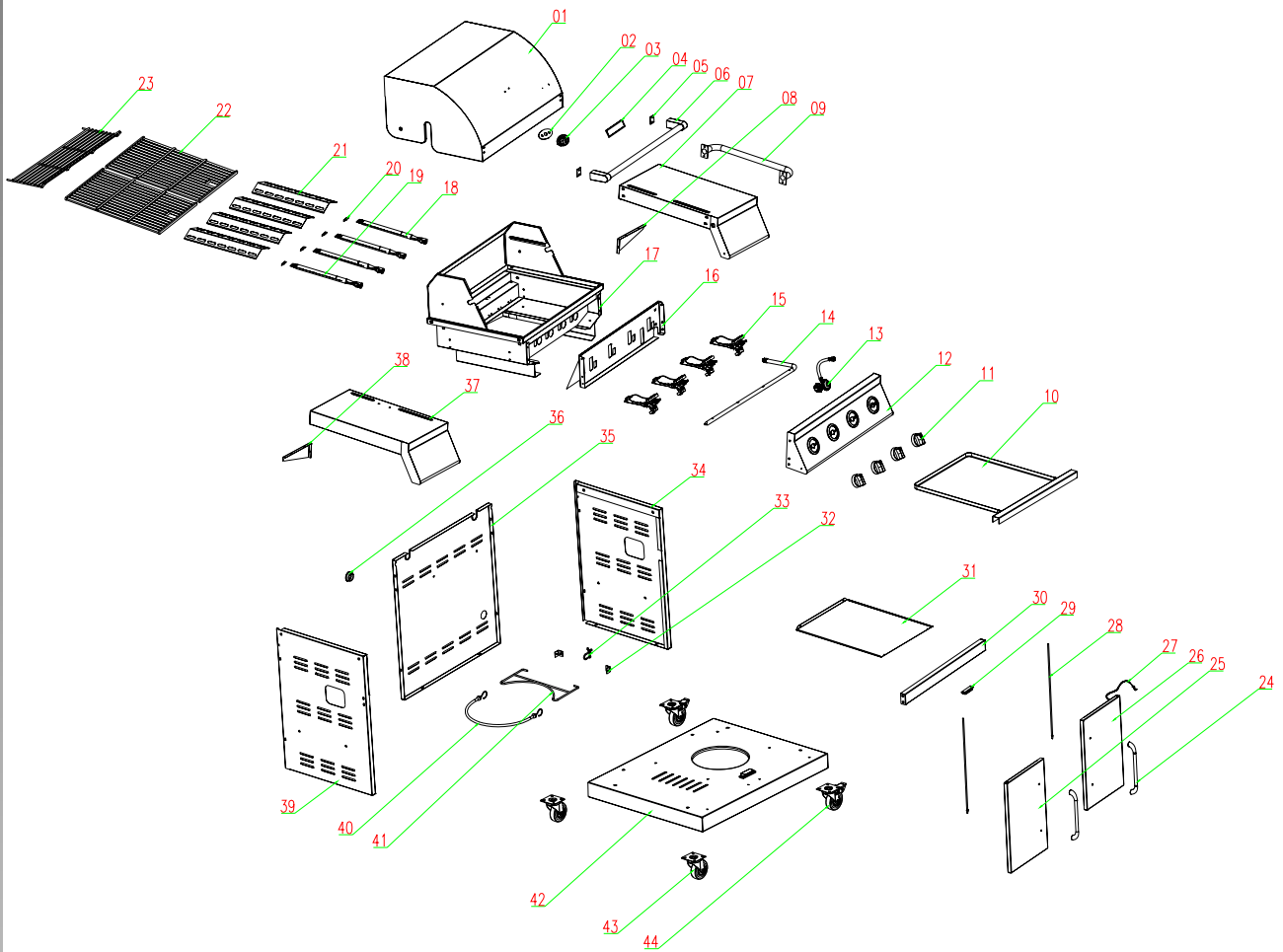







# ASSEMBLY INSTRUCTIONS

**PLEASE READ AND FOLLOW THE INSTRUCTIONS CAREFULLY  
STEP BY STEP**

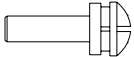
## **Tools Required:**

- #2 Philips head screwdriver (not provided)
- Hexagon/Allen wrench (provided).
- The following hardware is provided in the left side shelf carton:

Item	Description	Specification	Quantity
1	Truss head screw (With Split lock And Washer) 	1/4-20x1/2inch	12pcs
2	Truss head screw (With Split lock And Washer) 	3/16-24X3/8inch	2pcs
3	Truss head screw (With Split lock And Washer) 	5/32-32X3/8inch	2pcs
4	Hexagon/wrench 		1pcs

## **STEP I:**

- Take out grill body from packing carton, and remove all the packing materials.

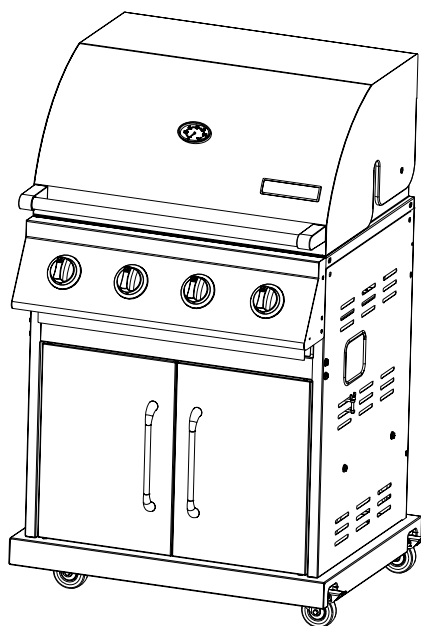

# ASSEMBLY INSTRUCTIONS

## **STEP II:**

- Take out left side shelf carton from cart, remove packing materials.
- Use two 1/4-20 x 1/2" screws to attach left side shelf from inside of firebox. Use two 1/4-20 x 1/2" screws to attach left side shelf from outside of firebox.
- Use one 5/32-32 x 3/8" screw to attach left side shelf bracket to left side shelf. Use one 3/16-24 x 3/8" screw to attach left side shelf bracket to control panel.

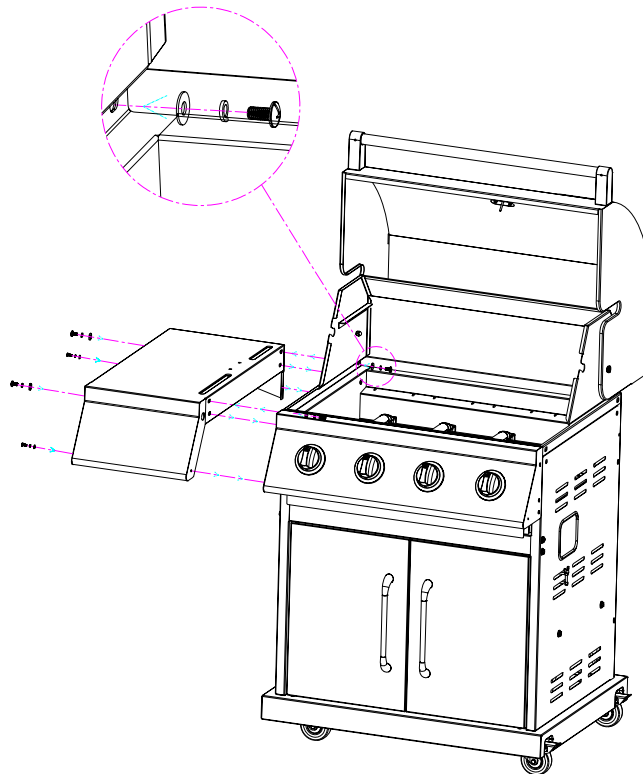

# ASSEMBLY INSTRUCTIONS

## **STEP III:**

- Take out right side shelf carton from cart, remove packing materials.
- Use two 1/4-20 x 1/2" screws to attach right side shelf from inside of firebox. Use two 1/4-20 x 1/2" screws to attach right side shelf from outside of firebox.
- Use one 5/32-32x3/8" screw to attach right side shelf bracket to right side shelf. Use one 3/16-24x3/8" screw to attach right side shelf bracket to control panel.
- Use four 1/4-20 x 1/2" screws to attach the push bar to the right shelf.

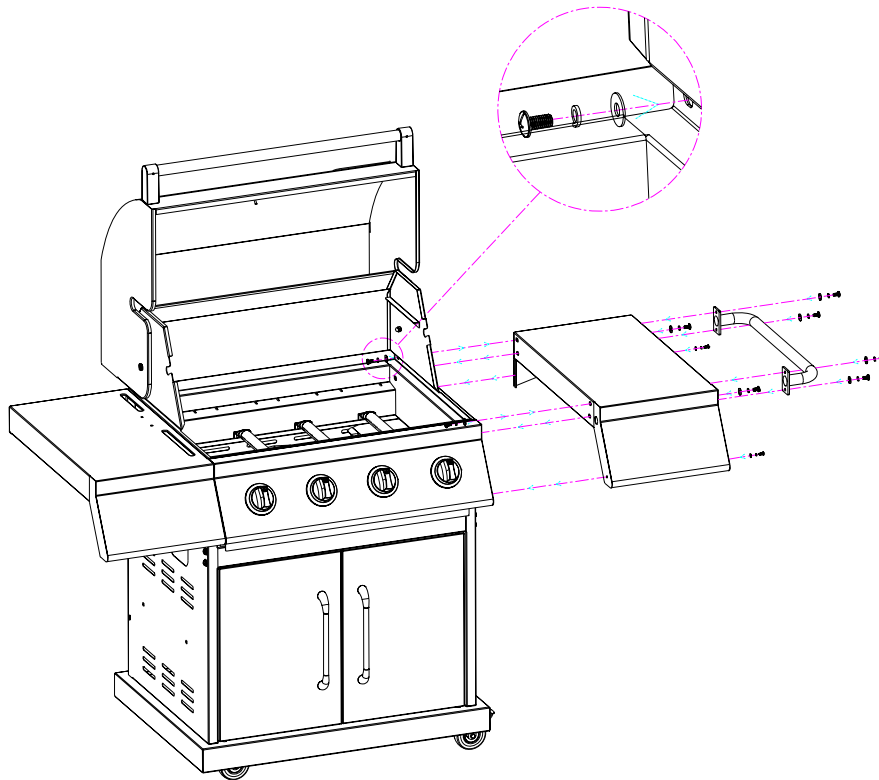

# ASSEMBLY INSTRUCTIONS

## **STEP IV:**

- Remove packing material from flame tamers, cooking grids, warming rack , then place them in the proper positions shown below.

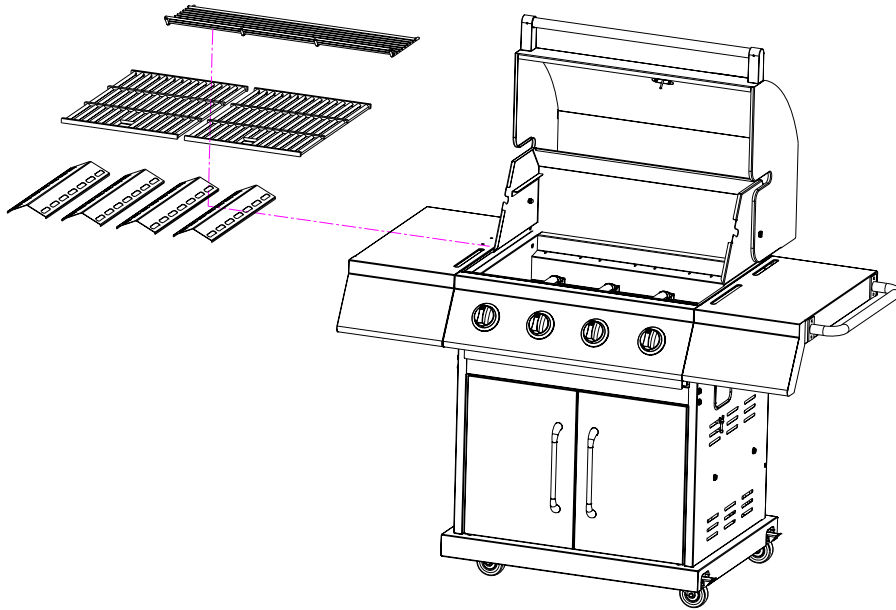

## **STEP V:**

- When the grill is in the desired location, lock the caster brakes, this will keep the grill unit in place for safe operation.

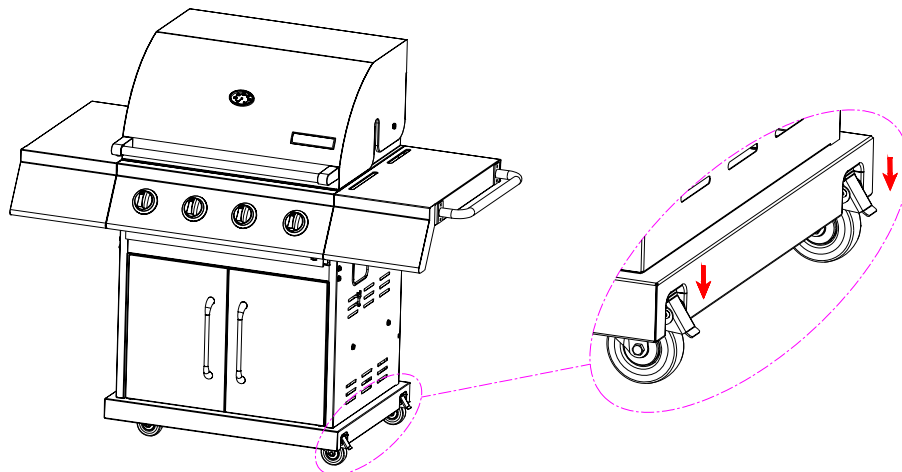

# ASSEMBLY INSTRUCTIONS

## **SAFETY NOTICE:**

▪ If it becomes necessary to replace the regulator assembly supplied with this grill, ensure the regulator hose is treaded through retaining ring attached to right side panel as figure shows bellow.

## **NOTE:**

REPLACEMENT PRESSURE REGULATOR AND HOSE ASSEMBLIES MUST BE THOSE SUPPLIED BY THE MANUFACTURER.

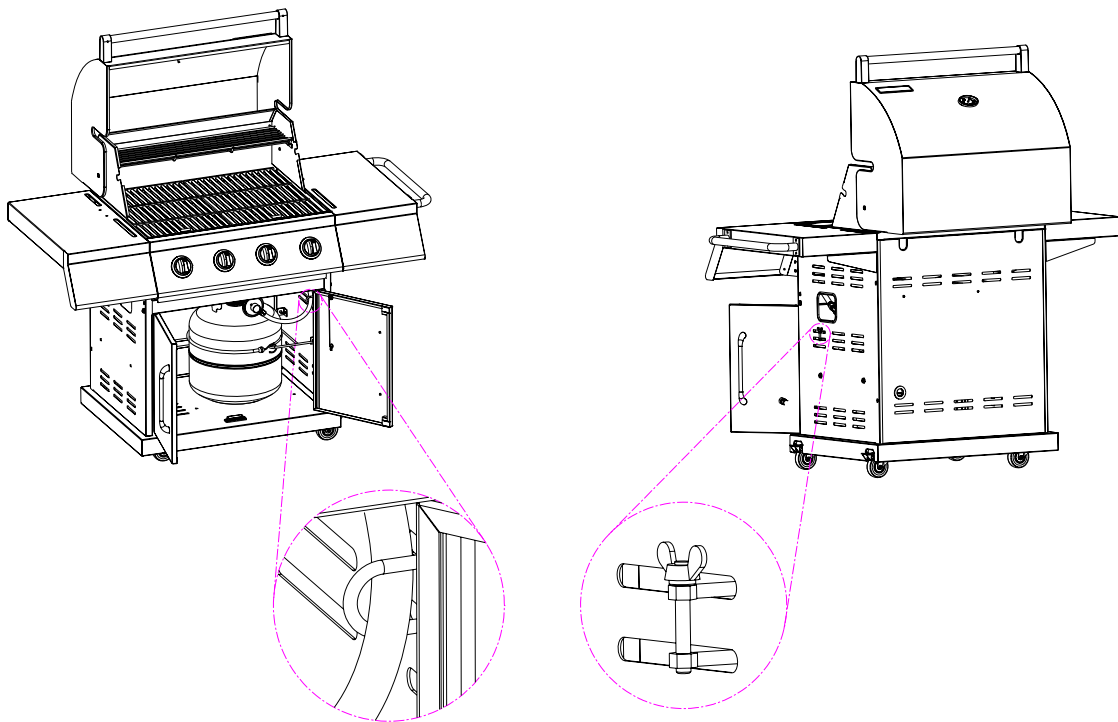

# GAS CONNECTION

## **ONLY USE THE REGULATOR AND HOSE ASSEMBLY PROVIDED WITH THIS GRILL. REPLACEMENT PRESSURE REGULATORS AND HOSE ASSEMBLIES MUST BE THOSE SUPPLIED BY THE MANUFACTURER**

This is a LP (Liquefied Petroleum Gas) configured grill. Do not attempt to use a natural gas supply unless the grill has been reconfigured for natural gas use.

The installation of this appliance must conform with local codes or, in the absence of local codes, with either the National Fuel Gas Code, ANSI Z223. 1, or CAN/CGA-B149.2 Propane Installation Code.

### **▪ LP TANK REQUIREMENTS – THE LP TANK USED WITH YOUR GRILL MUST MEET THE FOLLOWING**

- 1) Measurement: 12”(30.5cm) (Diameter) X 18” (45.7cm) (Tall) .
- 2) Maximum Capacity: 20lbs(9Kg).
- 3) Constructed and marked in accordance with the specification for LP-gas cylinders of the U.S. Department of Transportation (DOT) or the National Standard of Canada, CAN/CSA-B339, Cylinders, Spheres and Tubes for the Transportation of Dangerous Goods. See LP tank collar for marking.
- 4) Is arranged for vapor withdrawal.
- 5) Includes a collar to protect the tank valve.
- 6) Has no dents or rust. A dented or rusty LP tank may be hazardous, and should be checked by your supplier.
- 7) Provides a shut-off valve terminating in an LP gas tank valve outlet specified, as applicable for connection type QCC1 in the standard for compressed gas tank valve outlet and inlet connection ANSI/CGA-V-1.

### **▪ LP TANK VALVE USED MUST MEET THE FOLLOWING**

- 1) Have type I outlet compatible with regulator provided.
- 2) Have safety relief valve.
- 3) UL listed Overfill Protection Device (OPD), This OPD safety feature is identified by a unique triangular hand wheel. Only use tanks equipped with this type of valve. (As the figure shown on the next page)

### **▪ FOR YOUR SAFETY**

Ensure that the black plastic grommets of the regulator provided are in place and that the hose does not come into contact with the heat shield or the grill head.

# GAS CONNECTION

## ▪ CONNECT THE REGULATOR TO THE LP TANK

### VERY IMPORTANT:

- THE REGULATOR SHALL NOT BE IN A LOCATION THAT WILL ATTAIN A TEMPERATURE ABOVE 140°F (60°C) .
- THE REGULATOR SHALL INCORPORATE A PRESSURE RELIEF VALVE OR OVERPRESSURE DEVICE.
- THE INLET OF THE PRESSURE REGULATOR SHALL BE FITTED TO CONNECT THE TYPE I CONNECTION OF THE TANK VALVE PER ANSIZ21.81.

- 1) Make sure tank valve is in its full off position (turn clockwise to stop).
- 2) Check tank valve to assure it has proper external male threads (type I connection per ANSIZ21.81).
- 3) Make sure all burner knobs are in their off position.
- 4) Remove the protective cap from LP tank valve. Always use cap and strap supplied with valve.
- 5) Inspect valve connection port and regulator assembly. Look for any damage or debris. Remove any debris. Inspect hose for damage. Never attempt to use damaged or plugged equipment. Contact your local LP gas dealer for repair.
- 6) When connecting regulator assembly to the valve, hand tighten nut clockwise to a positive stop. Do not use a wrench to tighten. Use of a wrench may damage quick coupling nut and result in a hazardous condition. (As figure shown below)

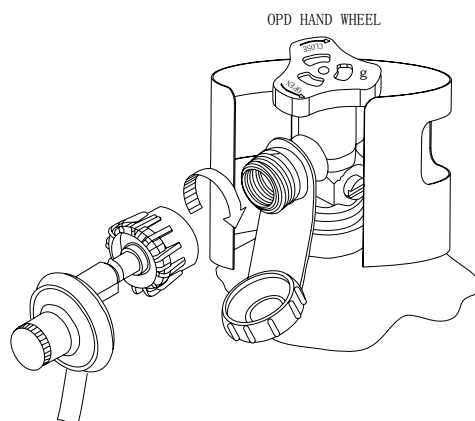

- 7) Open tank valve fully (counterclockwise). Use a soapy water solution to check all connections for leaks before attempting to light grill. If a leak is found, turn tank valve off and do not use grill until a local L.P gas dealer can make repairs.

# GAS CONNECTION



## WARNING

- Never insert any foreign objects into the valve outlet. It may damage the valve and cause leak, leaking gas may result in fire, explosion, heavy body injury, or even death.
- Do not connect this grill to the self-contained LP gas system of a motor home or camper trailer.
- Do not use this grill until leak tested.
- STOP and call the fire department if any leaks are detected.
- If you cannot stop a gas leak, close the LP tank valve IMMEDIATELY, call LP gas supplier or the fire department.



## DANGER

- NEVER store a spare LP tank under or near grill or in an enclosed area.
- NEVER fill the tank beyond 80% full. An overfilled spare LP tank is dangerous because surplus gas may leak from safety relief valve. The safety relief valve on a LP tank could activate to release gas and cause a fire.
- The spare LP tank must have safety caps installed on the LP tank outlet.
- If any gas leaks are found on the spare LP tank, immediately step away from the grill, and call the fire department.

### VERY IMPORTANT:

#### **DISCONNECT THE TANK WHEN THIS GRILL IS NOT IN USE.**

- **To disconnect LP gas tank:**
  - 1) Turn all the knobs off.
  - 2) Turn the tank valve off fully (turn clockwise to stop).
  - 3) Detach the regulator assembly from tank valve by turning the quick coupling nut counterclockwise.
  - 4) Install the protective cap back onto the LP tank valve.



# LEAK TESTING

## ▪ **GENERAL**

Although all gas connections on the grill are leak tested at the factory prior to shipment, a complete gas tightness check must be performed at the installation site due to possible mishandling in shipment, or excessive pressure unknowingly being applied to the unit. Periodically check the whole system for leaks, or immediately check if the smell of gas is detected.

## ▪ **BEFORE TESTING**

- 1) Make sure that all packing material is removed from the grill including the burner tie-down straps.
- 2) Do not smoke while leak testing.
- 3) Never leak test with an open flame.
- 4) Make a soap solution with one part liquid detergent and another part water. Prepare a spray bottle, brush, or rag to apply the solution to the connections. For the initial leak test, make sure the LP cylinder is full.
- 5) Grill must be leak tested outdoors in a well-ventilated area, away from ignition sources such as gas fired or electrical appliances, and flammable materials.
- 6) Keep grill away from open flames and/or sparks while testing.

## ▪ **TO TEST**

- 1) Make sure all control knobs are in the "OFF" position.
- 2) Make sure the regulator is connected to the LP tank tightly.
- 3) Completely open LP tank valve by turning counter clockwise. If you hear a "POP" sound, turn gas off IMMEDIATELY, as it indicates a heavy leak at the connection. Call your gas dealer or fire department.
- 4) Check every connection from the LP tank up to and including the connection to the manifold pipe assembly (the pipe that goes to the burner) by brushing or spraying the soapy solution on the connections.
- 5) If soap bubbles appear, there is a leak. Turn off LP tank valve IMMEDIATELY and retighten connections, Open LP tank valve again, and recheck.
- 6) If leaks cannot be stopped, DO NOT ATTEMPT TO REPAIR. Call our service center at (888)-287-0735 for help.
- 7) Always close the LP tank valve after leak testing by turning clockwise.  
Only those parts recommended by the manufacturer should be used on the grill. Substitution will void the warranty. Do not use the grill until all connections have been checked and do not leak.

# LEAK TESTING

- **SAFETY TIPS:**

- 1) ALWAYS CHECK FOR LEAKS AFTER EVERY LP TANK CHANGE.
- 2) ALWAYS CHECK FOR LEAKS BEFORE EACH USE.
- 3) USE LONG BBQ TOOL TO AVOID BURNS.
- 4) CHECK ALL GAS SUPPLY FITTINGS FOR LEAKS BEFORE EACH USE. IT IS HANDY TO KEEP A SPRAY BOTTLE OF SOAPY WATER NEAR THE SHUT-OFF VALVE OF THE GAS SUPPLY LINE. SPRAY ALL THE FITTINGS. BUBBLES INDICATE LEAKS.
- 5) DISCONNECTED LP CYLINDERS MUST HAVE THREADED VALVE PLUGS TIGHTLY INSTALLED, AND MUST NOT BE STORED IN A BUILDING, GARAGE, OR ANY OTHER ENCLOSED AREAS.
- 6) TURN OFF ALL CONTROL KNOBS AND LP TANK VALVE WHEN THE GRILL IS NOT IN USE.
- 7) IF THE APPLIANCE IS STORED INDOORS, THE LP TANK MUST BE DISCONNECTED AND REMOVED FROM THE GRILL.
- 8) LP TANKS MUST BE STORED OUTDOORS IN A WELL-VENTILATED AREA. DISCONNECTED LP TANKS IN STORAGE OR BEING TRANSPORTED MUST HAVE A SAFETY CAP.
- 9) NEVER LEAVE A LP TANK IN A RECREATIONAL VEHICLE OR BOAT WHICH MAY BECOME OVERHEATED BY THE SUN.
- 10) DO NOT STORE LP TANK IN OR NEAR AN AREA WHERE CHILDREN PLAY.
- 11) FOR ANY OTHER PROBLEMS, SEE "TROUBLESHOOTING" OR CONTACT OUR SERVICE CENTER AT (888)-287-0735.

# FINAL INSTALLATION CHECKLIST

- At least 36" clearance maintained from combustible constructions to the sides and back of this grill.
- There is no unprotected combustible construction material over the grill.
- All internal packaging removed.
- Burners are sitting properly on orifices.
- Knobs turn freely.
- The regulator & hose connected to grill are provided by the manufacturer. (Pre-set for 11.0" water column).
- Unit tested and free of leaks.
- User informed of gas supply shut off valve location.

# GRILL LIGHTING INSTRUCTION

**VERY IMPORTANT: ALWAYS INSPECT THE HOSE PRIOR TO EACH USE.**

▪ **BEFORE LIGHTING:**

Inspect the gas supply hose before turning the gas "ON". If there is evidence of cuts, wear, or abrasion, it must be replaced before use. The replacement hose assembly must be that specified by the manufacturer.

▪ **VERY IMPORTANT: TO LIGHT MAIN AND SIDE BURNERS OF THE GRILL:**

- 1) Read instructions before lighting.
- 2) Turn all knobs to "OFF" then open the LP tank valve. Always keep your face and body as far from the grill as possible when lighting.
- 3) Open lid during lighting.
- 4) Push and turn any control knob slowly to "HI" position. The built-in igniter will click and spark simultaneously to light the pilot and burner in sequence. Turn the control knob to OFF IMMEDIATELY if the burner does not light within 5 seconds. Wait 5 minutes for gas to dispel, then repeat the lighting procedure.
- 5) Follow match lighting instructions if burner can't be lit after repeating 3-4 times.

▪ **TO LIGHT THE MAIN BURNER BY MATCH: (AS THE FOLLOWING FIGURE SHOWS)**

If the burner will not light after several attempts then the burner can be match lit.

Tools: Lighting rod (hanging behind the right door)

Usage:

- 1) Read instructions before lighting.
- 2) Open the lid during lighting.
- 3) Simply place a lighted match between the coils on the end of the lighting rod and hold next to the burner to ignite.
- 4) Push and turn the knob to "HI" position, make sure the burner lights and stays lighted.
- 5) Repeat 3.4 to light other burners.
- 6) Keep a spray bottle of soapy water near the gas supply valve and check the connections before each use. Do not light the grill if odor of gas is present, call out service center at (888)-287-0735.

# GRILL LIGHTING INSTRUCTION

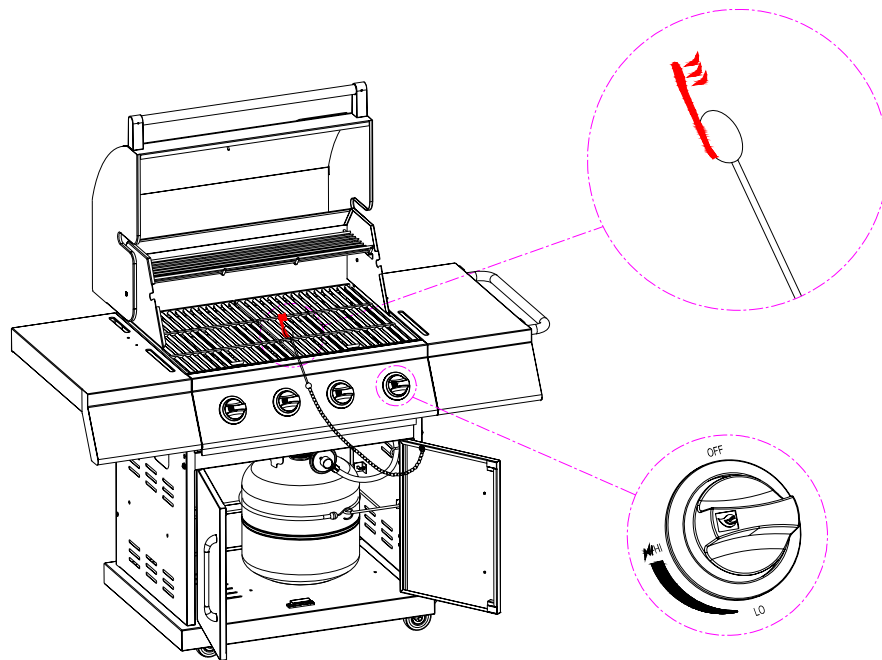

- **FLAME CHARACTERISTICS:**

- 1) Check for proper burner flame characteristics. Each burner is adjusted prior to shipment; however, variations in the local gas supply may take subtle necessary adjustments.
- 2) Burner flames should be blue and stable with small yellow tips, no excessive noise, or lifting. If any of these conditions exist call our customer service line. If the flame is yellow, it indicates insufficient air. If the flame is noisy and tends to lift away from the burner, it indicates too much air.
- 3) Small yellow tips are ok.

# OPERATING INSTRUCTION



## CAUTION

- Clean the grill often. A grease fire that may damage the grill may occur if the grill has not been cleaned frequently.
- NEVER leave the grill unattended while using.
- Do not use water to extinguish the grease fire, it may cause body injury. Turn knobs off and LP tank off in case grease fire occurs.
- Grease fire can't be put out by closing the lid. Turn off knobs and LP tank IMMEDIATELY if any grease fire occurs.



## WARNING

For your safety:

- Keep grill area clear and free from any flammable material.
- NEVER let children operate the grill or play near the grill.
- This grill is for outdoor use ONLY. NEVER use in a enclosed area such as a carport, porch, covered patio, garage, or under a surface that can catch fire.
- Do not block the ventilation holes in the four sides of the grill cart, it may affect the combustion performance of the burner due to insufficient air.
- Use the grill at least 36" away from any wall or surface. 120" away from objects that may spark and ignite gas i.e. live electrical appliances, pilot lights of water heaters.
- Do not use this grill on or under wood balconies.
- This grill is designed to use only LP gas, DO NOT use lava rock, briquets, charcoal on it.
- NEVER light the burner with the lid closed. Non-ignited gas accumulated inside a closed grill may cause explosions.
- Check the burner flames periodically.
- Turn off the gas supply when the grill is not in use.
- Always turn off the LP tank completely and detach from the grill before moving.

# OPERATING INSTRUCTION

- **TOTAL GAS CONSUMPTION:**

Total gas consumption (per hour) of PG-50403SRL grill with all burners on "HI":

Main burners	48,000 Btu/hr
Total	48,000 Btu/hr

- **GENERAL USE OF THE GRILL:**

The grill burners encompass the entire cooking area and are side ported to minimize blockage from falling grease and debris. Above the burners are stainless steel radiated. The igniter knobs are located on the valve panel. Follow the lighting instructions printed on the control panel.

- **USING THE GRILL:**

Grilling requires high heat for searing and proper browning. Most foods are cooked at the "HI" heat setting for the entire cooking time. However, when grilling large pieces of meat or poultry, it may be necessary to turn the heat to a lower setting after the initial browning. This cooks the food through without burning the outside. Foods cooked for a long time or basted with a sugary marinade may need a lower heat setting near the end of the cooking time.

- 1) Make sure the grill has been leak tested and is properly located.
- 2) Remove any packing material.
- 3) Light the grill burners using the instructions in this manual.
- 4) Turn the control knob to "HI" and preheat the grill for 15 minutes.
- 5) The grill lid is to be closed during the appliance preheat period.
- 6) Place the food on the grill and cook to the desired doneness. Adjust heat setting, if necessary. The control knob may be set to any position between "HI" and "LO".
- 7) The grill is designed to grill efficiently without the use of lava rocks or briquettes of any kind. Heat is radiated by the stainless steel flame tamers under the cooking grids.
- 8) The hot grill sears the food, sealing in the juices. The longer the preheat, the faster the meat browns.

# CARE & MAINTENANCE

## MAINTENANCE

- 1) Keep the grill area clear and free from combustible materials, gasoline and other flammable vapors and liquids.
- 2) Keep the holes in the three sides of the cart clear and free from debris, thus ensure the flow of combustion and ventilation air is unobstructed.
- 3) Visually check burner flames as following:
  - Remove cooking grids and flame tamers.
  - Light burners.
  - Turn knobs from "HI" to "LO", check the flame status, the flame in "LO" position should be smaller than in HI position, as figure shown below.
  - Always check flame before each use, see TROUBLESHOOTING if any abnormal status found.
- 4) Call our after service center at (888)-287-0735 for warranty replacement parts.



## CLEANING

### 1) COOKING AREA CLEANING

The easiest way to clean the grill is to clean immediately after turning off the flame when cooking is completed. Wear a barbeque mitt to protect your hand from the heat and steam. Dip a brass bristle barbeque brush in tap water and scrub the hot grill. Dip the brush frequently in the water. Steam, created as water contacts the hot grill, assists the cleaning process by softening any food particles. The food particles will fall and burn. Never immerse a hot part in water.

### 2) GRILL BURNER CLEANING

- Be sure the tank valve and the knobs are in the "OFF" position. Make sure the grill is cool.
- Clean the exterior of the burner with a wire brush. Clear stubborn scale with a metal scraper. Clear any clogged ports with a straightened paper clip. Never use a wooden toothpick as it may break off and clog the port.
- Please note that if insects or other obstructions are blocking the flow of gas through the burner, you will need to call our customer service line.

**VERY IMPORTANT: The orifice of the valve must be located in the center of the burner section after removal and cleaning. Otherwise, it may cause serious bodily injury and property damage. Swing the burner slightly after replacing to check whether it has been installed properly.**

### 3) GREASE TRAY CLEANING

The grease tray should be emptied and wiped down periodically and washed in a mild detergent and warm water solution. A small amount of sand may be placed in bottom of the grease tray to absorb the grease.

# TROUBLE SHOOTING

## ▪ SPIDER AND INSECT WARNING

Spiders and insects can nest in the burners after storing. These nests can cause fires inside the tube or beneath the grill. This is a very dangerous condition. So always clean the burners before use.

## ▪ WHEN TO LOOK FOR SPIDERS

Inspect the burners at least once a year or immediately if any of the following conditions occur:

- 1) Yellow flame with burning smell.
- 2) Temperature wont rise.
- 3) Heats unevenly.
- 4) Burners make popping noises.

## ▪ BEFORE CALLING FOR SERVICE

Please check the following problems/solutions before contact our service center.

PROBLEMS	POSSIBLE CAUSE	SOLUTIONS
Burner won't light after turning and pushing the knobs	Electrode deposited with cooking residues	Use clean swab and alcohol to clean.
	Electrode damaged	Replace.
	Electrode wires are loose or fall off	Reconnect or replace with new electrode assembly with wires.
	Orifice blocked	Check the orifice for blockage.
	Wire is shorting	Replace with new electrode assembly with wires.
Burner can't light by match	No gas	Open the LP tank valve / Replace LP tank valve
	Gas flow is not smooth	Clear burner tubes
	Incorrect assembly between burner and valve	Re-assemble
Yellow or orange flame with gas odor	Incomplete combustion	Call our customer service center at (888)-287-0735
Low heat with knob in "HI" position.	Gas hose bent or kinked	Smooth out the hose.
	Burner or orifice blocked.	Clear blockage.
	Low gas pressure	Call the gas dealer.
	Grill not preheated	Preheat the grill for 15 minutes.
Flare-up	Excessive meat fat	Cut off fat before grilling.
	Temp. too high	Adjust
	Grease deposit	Clean
Flame out	High winds	Find a less windy place.
Flame lifting	Too high of a gas pressure	Call the gas dealer.
Flashback	Burner port blocked	Clean burner port.
Grease fire	Grease accumulated in food	Turn off knobs and LP tank valve. Leave lid open and let fire burn out. Clean the grill after cooling.



# FOOD SAFETY

- **FOOD SAFETY:**
  - 1) Always follow the following tips to enjoy safe and healthy outdoor grilling.
  - 2) Always use hot soapy water to wash hands, surfaces & utensils after processing raw meat.
  - 3) Always separate raw meat from cooked foods to avoid cross-contamination.
  - 4) Always use clean utensils to handle the food.
  - 5) Always cook the meat thoroughly to kill germs. Use a thermometer to inspect the inner temp. of the meat, if necessary.
  - 6) Place the cooked foods and leftovers promptly into the refrigerator when done eating.

**VERY IMPORTANT: DO NOT LEAVE THE GRILL UNATTENDED WHILE COOKING.**

# GRILL STORAGE

- **GRILL STORAGE:**
  - 1) Clean the grill.
  - 2) Store the grill in a well-ventilated, dry outdoor area. Keep out of the reach of children when LP tank is connected to the grill.
  - 3) Store the grill in dry indoors **ONLY** after the LP tank is turned off and removed. The LP tank must be stored outdoors, out of the reach of children. **NEVER** store the tank in a building, garage or any other enclosed area.
  - 4) Put on the supplied vinyl cover (if supplied).

# PRODUCT REGISTRATION

Thank you for purchasing the PermaSteel Grill. In order to register your product to receive streamlined customer service, please fill out the following Product Registration form and (1) fax the form and a copy of your receipt to FAX # 909-287-0733, or (2) mail the form and a copy of your receipt to PermaSteel Inc, 14231 Fern Ave., Building 10, Chino, CA 91710.

## PRODUCT REGISTRATION

First Name: \_\_\_\_\_ Last Name: \_\_\_\_\_

Address: \_\_\_\_\_

City: \_\_\_\_\_ State: \_\_\_\_ Zip Code: \_\_\_\_\_

Email Address: \_\_\_\_\_ Phone: \_\_\_\_ - \_\_\_\_ - \_\_\_\_\_

Product Model #: \_\_\_\_\_ Date of Purchase: \_\_\_\_/\_\_\_\_/\_\_\_\_

Retail Store Location of Purchase: \_\_\_\_\_

Please rate the importance of each feature (1=least important; 10=most important)

Quality \_\_\_\_ Price \_\_\_\_ Size/Capacity \_\_\_\_ Cooking Area \_\_\_\_ Appearance \_\_\_\_

Other \_\_\_\_

What other brands did you seriously consider before making this purchase?

DCS\_ CharBroil\_ Brinkman\_ Members Mark\_ Lynx\_ Other\_

Did not consider other brands\_

How did you hear about our product?

Magazine Ad\_ Catalog\_ Salesperson\_ Word of Mouth\_ Internet\_

Store Display\_ Other\_

Marital Status

Single\_ Married\_

Household Income

Below \$50,000\_ \$50,000-\$150,000\_ \$150,000+\_

Education

High School\_ College\_ Graduate School\_

Primary Residence

Own\_ Rent\_

Comments/Suggestions: \_\_\_\_\_

\_\_\_\_\_



PERMASTEEL, INC.  
14231 Fern Ave., Building 10,  
Chino, CA 91710

TEL: (888)-287-0735  
FAX: (909)-287-0733

EMAIL: [SERVICE@PERMASTEEL.NET](mailto:SERVICE@PERMASTEEL.NET)